

SINGLE PIECE AXLE NUT

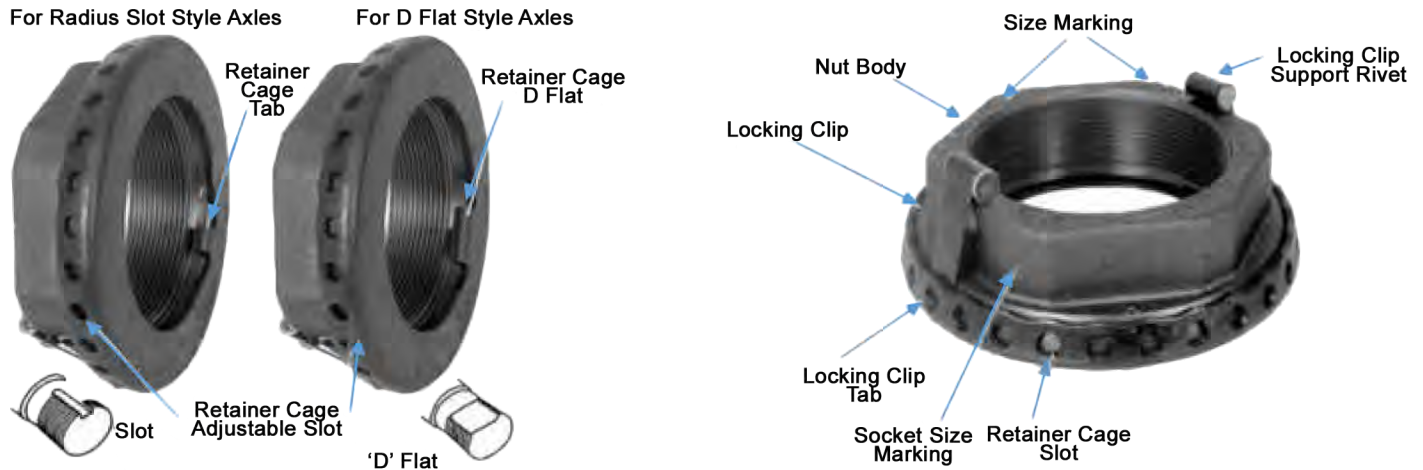

The first true single piece axle nut design delivers accurate adjustments within .001" which will extend the wheel bearing and seal service life. Adjustments are made in half the time others require and deliver TMC's recommended end play range every time.

The design is superior to the three piece style jamming nut system and two piece models that require locking keepers. This nut requires only one installation tool, a six point socket & torque wrench. Available for trailer, drive and steer axles with the standard "D" flat or slotted spindles.

Dayton Parts	Spindle Nut Specifications	Std Pkg Qty	Stemco 2-piece Pro Torq	Metform Protier Axilok
TS4123480	TRAILER, 3.480"-12 (slot type) 22,500# Trailer Axle Fruehauf Propar, Meritor TP, Dana/Eaton P22	1	447-4723	AX12-3480
TS4162625	TRAILER, 2.625"-16 (slot type) 22,500# Trailer Axle Meritor, Standard Forge, Dana, Eaton	1	447-4743	AX16-2625
TS4121500	STEER, 1.5"-12 ("D" Flat Spindle) 12,000# Steer Axle Meritor, Navistar/IHC	1	448-4836	AX12-1500
TS4181500	STEER, 1.5"-18 (slot type) 12,000# Steer Axle Eaton, Ford, Meritor	1	448-4837	AX18-1500
TS4123250	DRIVE, 3.25"-12 (slot type) 30,000# - 46,000# Tandem Eaton, Ford, Freightliner, KW Western Star, Peterbilt, Navistar/IHC, Volvo, GM	1	449-4973	AX12-3250

Visit us at www.daytonparts.com

Dayton Parts, LLC • PO Box 5795 • Harrisburg, PA 17110-0795 • 800-233-0899 • Fax 800-225-2159

Dayton Parts/Batco • 12390 184th Ave. • Edmonton, Alberta T5V 0A5 • 800-661-9861 • Fax 888-207-9064

Dayton Parts, LLC • 6039 Ordan Dr. • Mississauga, ON L5T 2M7

Dayton Parts, LLC • 1605 Lakeway Dr. • Lewisville, TX 75057

Self Adjusting Clutches

Update #2400

Attention: Dayton Parts' Distributors and Business Partners.

Now available from Dayton Parts LLC.

Self Adjusting Clutches

Features and Benefits:

- Dual Cam Springs — Two Springs (as opposed to a single spring) connect the two mated adjusting cams to create a stronger and more balanced actuation when adjusting.
- Over-Adjustment Protection — There are 2 internal straps connecting the cover to the adjusting ring to hold them in place when a shock occurs to the vehicle (like a more than gentle dock collision).
- No Internal Clutch Adjustment — Clutch self-adjusts to eliminate the additional labor costs of regularly scheduled manual adjustments.
- Wear Indicator — Wear indicator tab provides easy check of clutch wear.
- Brake Squeeze — Maintains brake squeeze adjustment for smooth shifting.

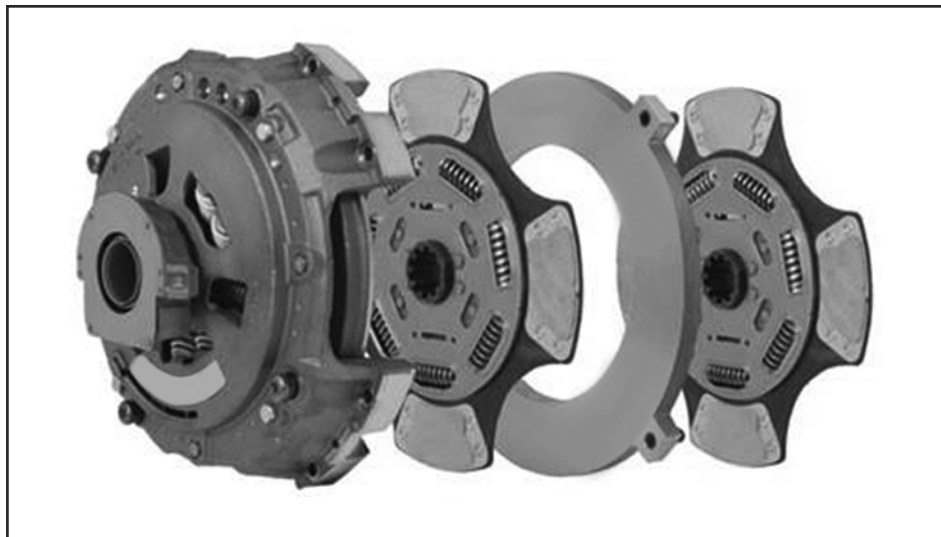

SS209701-82	Easy Pedal type, Self Adjusting Clutch, 7 Springs, 6 Paddles, 1700 lbs. Torque rating
SS209701-20	Easy Pedal type, Self Adjusting Clutch, 7 Springs, 6 Paddles, 1860 lbs. Torque rating
SS209701-51	Easy Pedal type, Self Adjusting Clutch, 9 Springs, Mack only, 6 Paddles, 1700 lbs. Torque rating
SS209701-91	Easy Pedal type, Self Adjusting Clutch, 9 Springs, Mack only, 6 Paddles, 1860 lbs. Torque rating
SS209701-74	Easy Pedal type, Self Adjusting Clutch, 10 Springs, 6 Paddles, 1650 lbs. Torque rating
SS209701-93H	Easy Pedal type, Self Adjusting Clutch, 10 Springs, 6 Paddles, 1860 lbs. Torque rating
SS209701-25	Easy Pedal type, Self Adjusting Clutch, 10 Springs, 6 Paddles, 2050 lbs. Torque rating

In stock at our Harrisburg, PA and Lewisville, TX warehouses to add to your regular stock order.
Check on-line for pricing at daytonparts.com

Call 800-233-0899 today to place your order.

A handwritten signature in black ink that reads "Steven S. Wolf".

Steven S. Wolf
Axle Group Product Manager

Visit us on the World Wide Web at www.daytonparts.com

Dayton Parts, LLC • PO Box 5795 • Harrisburg, PA 17110-0795 • 800-233-0899 • Fax 800-225-2159
Dayton Parts/Batco • 12390 184th Street • Edmonton, Alberta T5V 0A5 • 800-661-9861 • Fax 888-207-9064



New Product - Dodge Shackle, Rear

Update #2378

Attention: Dayton Parts' Distributors and Business Partners.

Dayton Parts would like to make you aware of new product availability:

Dayton Part Number: 330-413

Dodge Shackle, ref 52039204

Used on Ram and Dakota (1997-2011) with 2 1/2" wide rear springs



330-413 Shackle

Call 800-233-0899 today to place your order.

Earl Rabold
Product Manager/Suspensions

Visit us on the World Wide Web at www.daytonparts.com

Dayton Parts, LLC • PO Box 5795 • Harrisburg, PA 17110-0795 • 800-233-0899 • Fax 800-225-2159
Dayton Parts/Batco • 12390 184th Street • Edmonton, Alberta T5V 0A5 • 800-661-9861 • Fax 888-207-9064

To: Our Valued Dayton Parts Distributors

Subject: New drag link numbers

At Dayton Parts we're constantly updating our existing product lines with new additions. In this bulletin, we've added 13 new drag links to expand our coverage to newer applications. All of these are available and can be added to your next Dayton Parts Stock Order. See the new supplemental WD Price List P3BF2015-1(USA) or P3BF2015-2CAN(CANADA) for current pricing.

DRAG LINK LENGTH CHART - Sorted by Dimensions

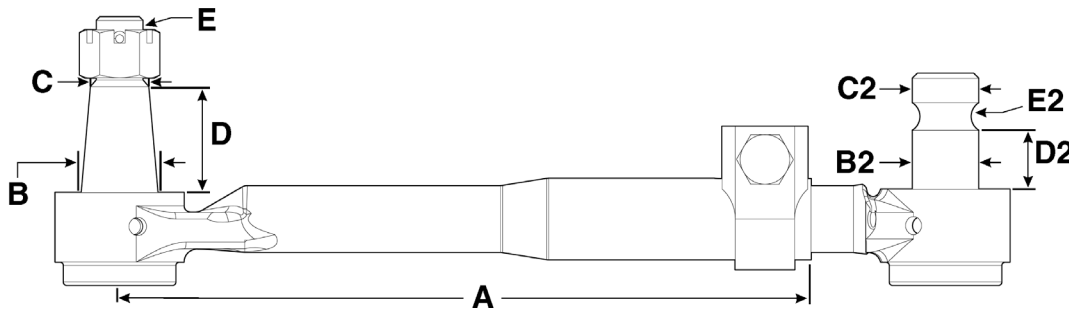

Length (A)	Part No.	Large Dia. (B)	Small Dia. (C)	Taper Len. (D)	Stud Thrd. (E)	Large Dia. (B2)	Small Dia. (C2)	Taper Len. (D2)	Stud Thrd. (E2)	End	Make	Remarks
13.13"	346-523	1.25	1.08	1.36	7/8-14	1.25	1.25	1.38	Lock-slot	1R	Mack	(310-435) C to E = 'A' Measurement

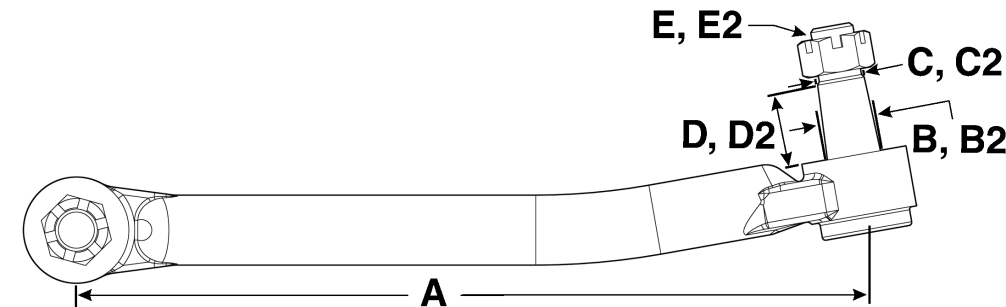

Length (A)	Part No.	Large Dia. (B)	Small Dia. (C)	Taper Len. (D)	Stud Thrd. (E)	Large Dia. (B2)	Small Dia. (C2)	Taper Len. (D2)	Stud Thrd. (E2)	End	Make	Remarks
16.40"	346-532	1.10	0.97	1.08	7/8-14	1.10	0.97	1.08	7/8-14	NR	IHC	

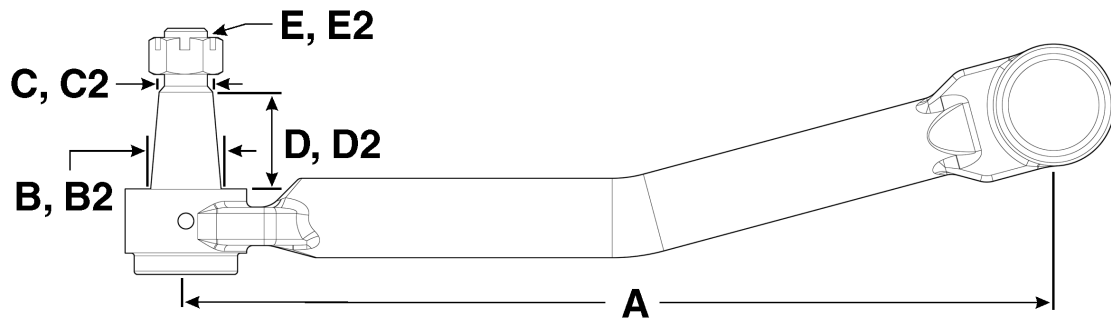

Length (A)	Part No.	Large Dia. (B)	Small Dia. (C)	Taper Len. (D)	Stud Thrd. (E)	Large Dia. (B2)	Small Dia. (C2)	Taper Len. (D2)	Stud Thrd. (E2)	End	Make	Remarks
18.28"	346-525	1.25	1.08	1.36	7/8-14	1.25	1.08	1.36	7/8-14	NR	Freightliner	

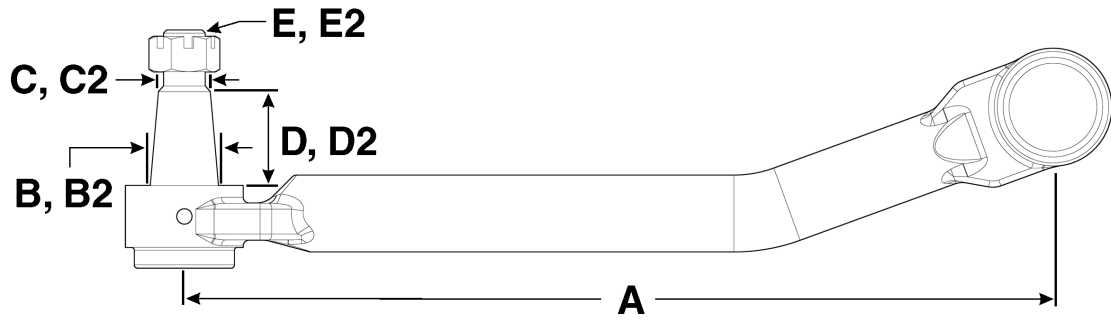

Length (A)	Part No.	Large Dia. (B)	Small Dia. (C)	Taper Len. (D)	Stud Thrd. (E)	Large Dia. (B2)	Small Dia. (C2)	Taper Len. (D2)	Stud Thrd. (E2)	End	Make	Remarks
18.85"	346-528	1.25	1.08	1.36	7/8-14	1.25	1.08	1.36	7/8-14	NR	Freightliner	

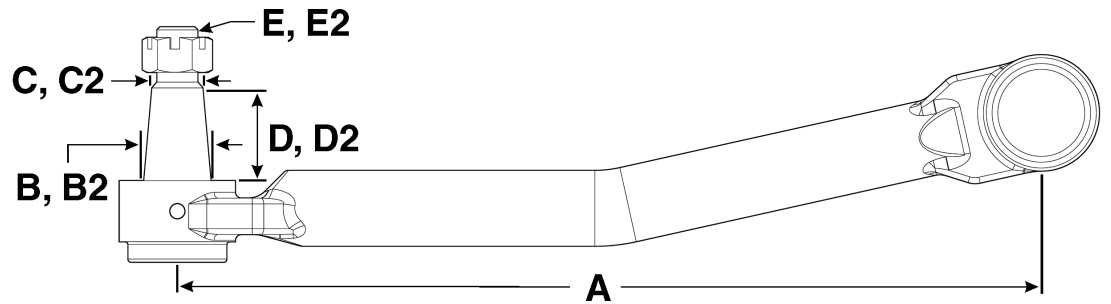

Length (A)	Part No.	Large Dia. (B)	Small Dia. (C)	Taper Len. (D)	Stud Thrd. (E)	Large Dia. (B2)	Small Dia. (C2)	Taper Len. (D2)	Stud Thrd. (E2)	End	Make	Remarks
18.92"	346-526	1.25	1.08	1.36	7/8-14	1.25	1.08	1.36	7/8-14	NR	Freightliner	

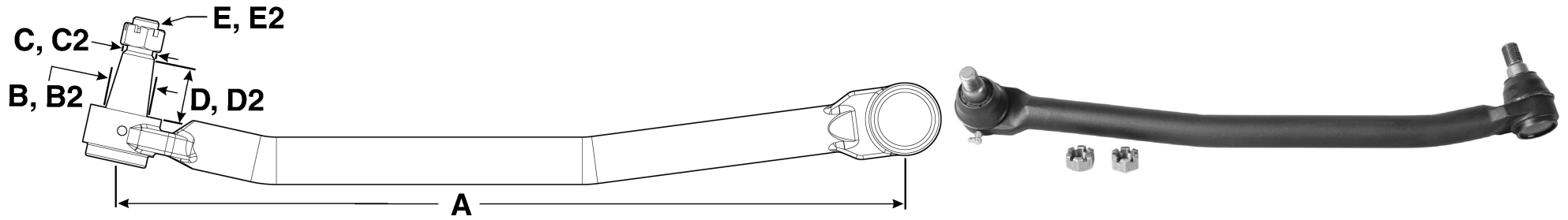

Length (A)	Part No.	Large Dia. (B)	Small Dia. (C)	Taper Len. (D)	Stud Thrd. (E)	Large Dia. (B2)	Small Dia. (C2)	Taper Len. (D2)	Stud Thrd. (E2)	End	Make	Remarks
27.53"	346-524	1.25	1.08	1.36	7/8-14	1.25	1.08	1.36	7/8-14	NR	Freightliner	

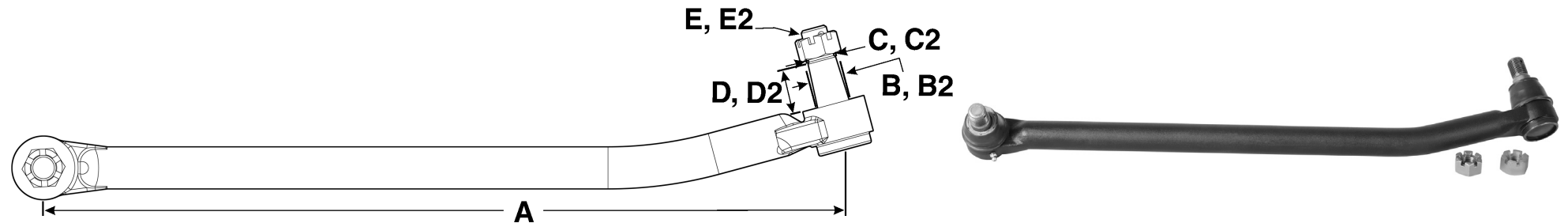

Length (A)	Part No.	Large Dia. (B)	Small Dia. (C)	Taper Len. (D)	Stud Thrd. (E)	Large Dia. (B2)	Small Dia. (C2)	Taper Len. (D2)	Stud Thrd. (E2)	End	Make	Remarks
28.06"	346-531	1.10	0.97	1.08	7/8-14	1.10	0.97	1.08	7/8-14	NR	IHC	

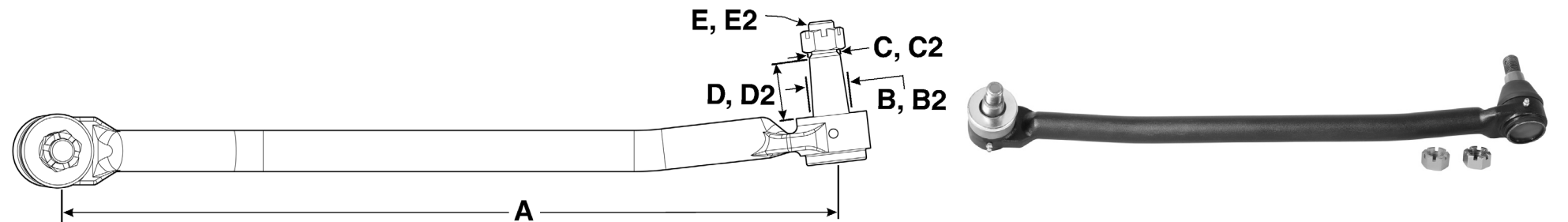

Length (A)	Part No.	Large Dia. (B)	Small Dia. (C)	Taper Len. (D)	Stud Thrd. (E)	Large Dia. (B2)	Small Dia. (C2)	Taper Len. (D2)	Stud Thrd. (E2)	End	Make	Remarks
28.19"	346-529	1.25	1.08	1.61	7/8-14	1.25	1.08	1.61	7/8-14	NR	IHC	

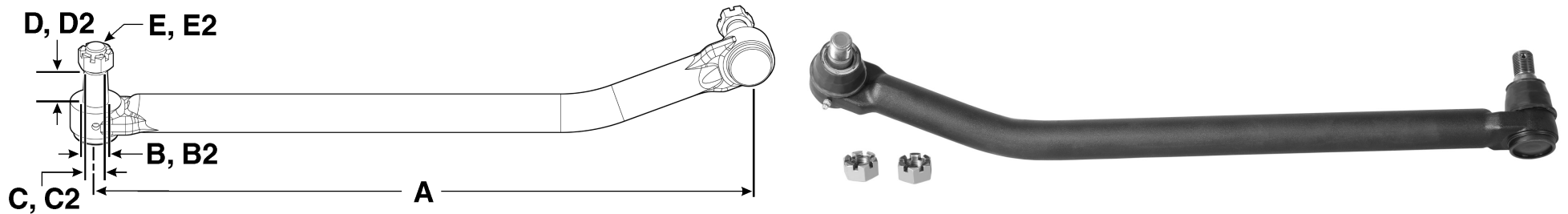

Length (A)	Part No.	Large Dia. (B)	Small Dia. (C)	Taper Len. (D)	Stud Thrd. (E)	Large Dia. (B2)	Small Dia. (C2)	Taper Len. (D2)	Stud Thrd. (E2)	End	Make	Remarks
28.28"	346-533	1.10	0.97	1.08	7/8-14	1.10	0.97	1.08	7/8-14	NR	IHC	

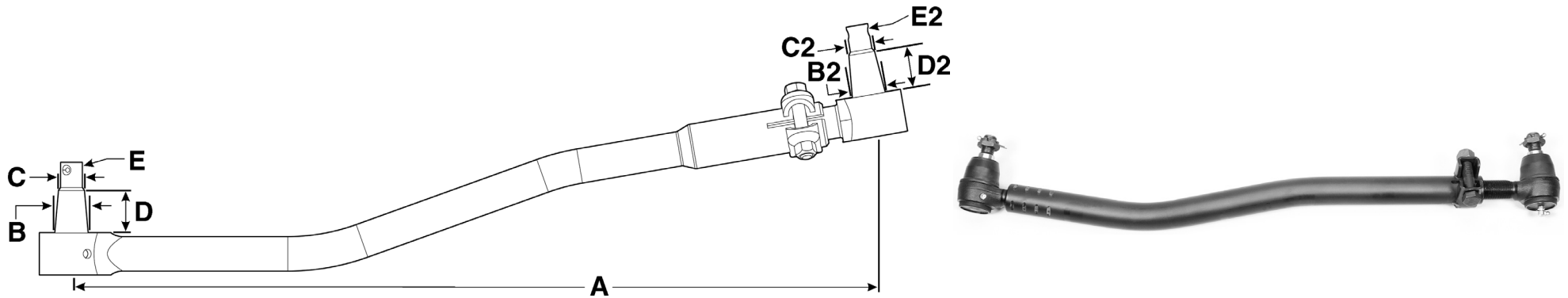

Length (A)	Part No.	Large Dia. (B)	Small Dia. (C)	Taper Len. (D)	Stud Thrd. (E)	Large Dia. (B2)	Small Dia. (C2)	Taper Len. (D2)	Stud Thrd. (E2)	End	Make	Remarks
28.67"	346-522	1.10	0.97	1.08	M20 x 1.5	1.13	0.99	1.10	M20 x 1.5	1R	Volvo/Mack	(310-444) C to E = 'A' Measurement

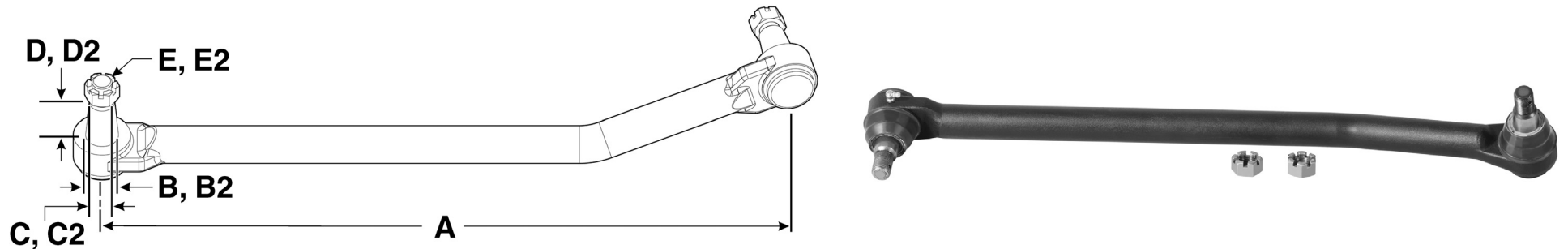

Length (A)	Part No.	Large Dia. (B)	Small Dia. (C)	Taper Len. (D)	Stud Thrd. (E)	Large Dia. (B2)	Small Dia. (C2)	Taper Len. (D2)	Stud Thrd. (E2)	End	Make	Remarks
30.28"	346-534	1.25	1.08	1.36	7/8-14	1.25	1.09	1.61	7/8-14	NR	IHC	

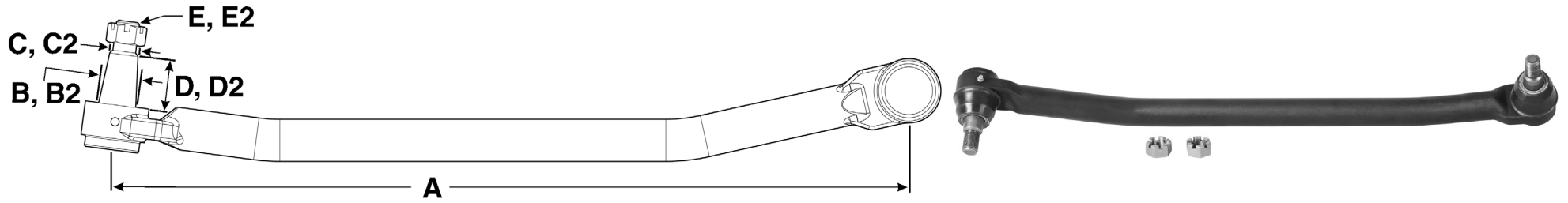

Length (A)	Part No.	Large Dia. (B)	Small Dia. (C)	Taper Len. (D)	Stud Thrd. (E)	Large Dia. (B2)	Small Dia. (C2)	Taper Len. (D2)	Stud Thrd. (E2)	End	Make	Remarks
31.47"	346-527	1.25	1.08	1.36	7/8-14	1.25	1.08	1.36	7/8-14	NR	Freightliner	

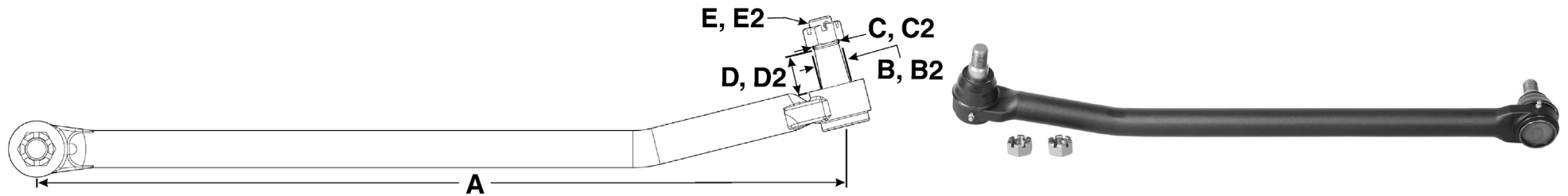

Length (A)	Part No.	Large Dia. (B)	Small Dia. (C)	Taper Len. (D)	Stud Thrd. (E)	Large Dia. (B2)	Small Dia. (C2)	Taper Len. (D2)	Stud Thrd. (E2)	End	Make	Remarks
31.75"	346-521	1.25	1.08	1.36	7/8-14	1.25	1.08	1.36	7/8-14	NR	Freightliner	

Replacement End: NR = Non-Replaceable / 1R = 1 Replaceable End / 2R = 2 Replaceable Ends

Call 800-233-0899 today to place your order.

Steven S. Wolf

Steven S. Wolf
Axle Group Product Manager

Visit us on the World Wide Web at www.daytonparts.com

Dayton Parts, LLC • PO Box 5795 • Harrisburg, PA 17110-0795 • 800-233-0899 • Fax 800-225-2159

DP/Batco Canada • 12390 184th Street • Edmonton, Alberta T5V 0A5 • 800-661-9861 • Fax 888-207-9064



**New Product - Freightliner
Hanger Assembly, Rear of Front
Includes RB-233 Bushing**

Update #2376

Attention: Dayton Parts' Distributors and Business Partners.

Dayton Parts would like to make you aware of new product availability:

Dayton Part Number: 338-2225

Freightliner Hanger, Rear of Front, ref 16-14735-000

RB-233 bushing included. Used on 4" wide front springs with RB bushings.

Use with 330-217 side bars and 334-1656 bolt assembly.

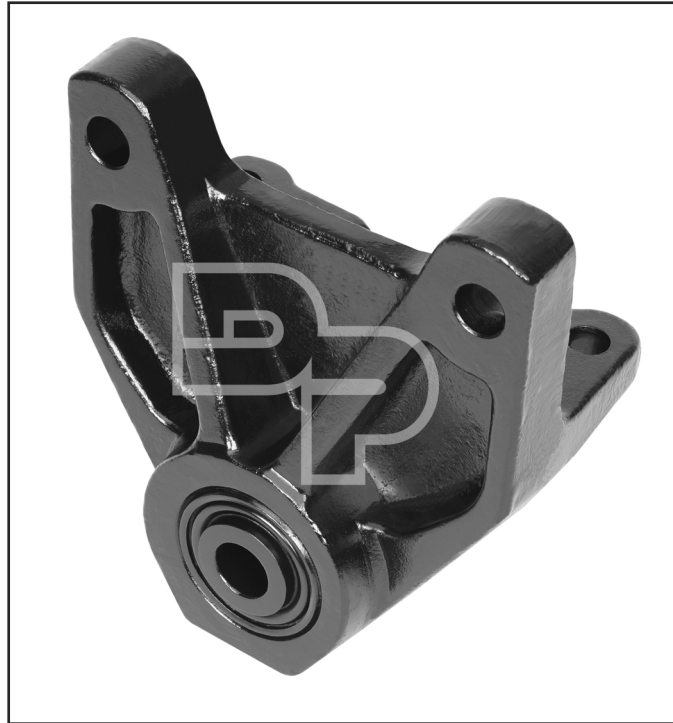

338-2225 Hanger, Rear of Front

Call 800-233-0899 today to place your order.

Earl Rabold
Product Manager/Suspensions

Visit us on the World Wide Web at www.daytonparts.com

Dayton Parts, LLC • PO Box 5795 • Harrisburg, PA 17110-0795 • 800-233-0899 • Fax 800-225-2159
Dayton Parts/Batco • 12390 184th Street • Edmonton, Alberta T5V 0A5 • 800-661-9861 • Fax 888-207-9064



New King Pin Set for Mack/Volvo

Update #2377

Attention: Dayton Parts' Distributors and Business Partners.

New **300-340** kingpin kit now in stock

300-340 replaces Mack kit # 301SQ53 and Volvo kit # 85108338. The Volvo kit does only one side and both OE kits do not include the tapered roller thrust bearings and races. This new kit is in stock in all four Dayton Parts warehouses. Check on-line for current wd pricing.

As always thanks for your continued support of Dayton Parts.



300-340 King Pin Set

Call 800-233-0899 today to place your order.

Steven S. Wolf
Axle Group Product Manager

Visit us on the World Wide Web at www.daytonparts.com

Dayton Parts, LLC • PO Box 5795 • Harrisburg, PA 17110-0795 • 800-233-0899 • Fax 800-225-2159
Dayton Parts/Batco • 12390 184th Street • Edmonton, Alberta T5V 0A5 • 800-661-9861 • Fax 888-207-9064

New Product Riser Blocks

Update #2374A (Rev A, Added SPA-10)

Attention: Dayton Parts' Distributors and Business Partners.

Dayton Parts would like to make you aware of new product availability: Riser Blocks

Inventory is available now for ordering.

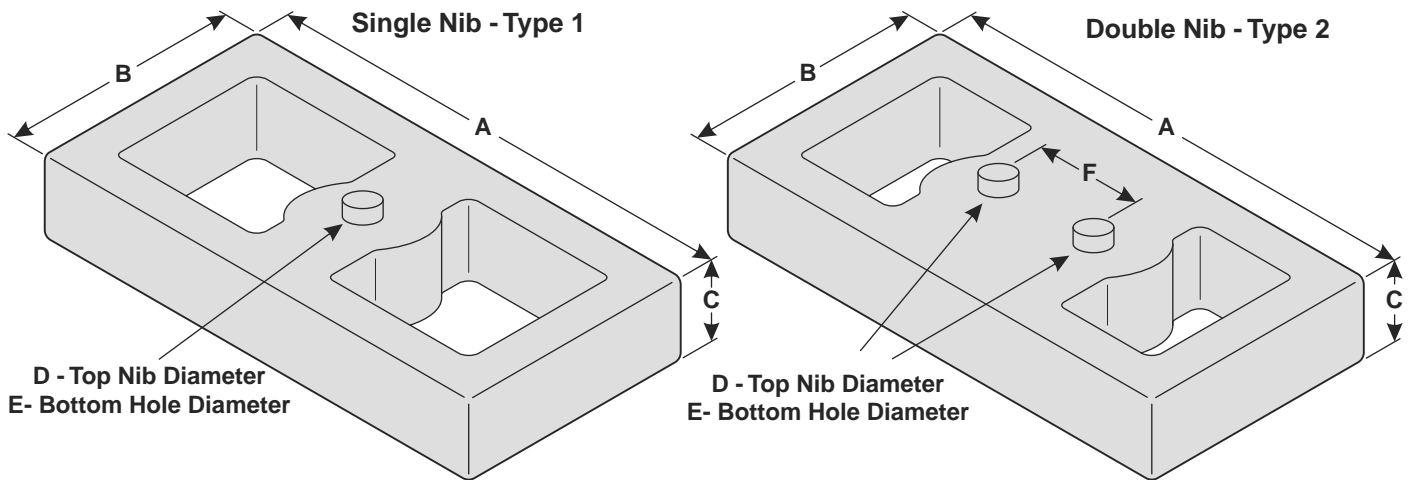

Type	Part No.	A	B	C	D	E	F	Use With
1	SPA-1	6"	2 1/2"	1"	.55"	.58"	—	3/8" Center Bolt
1	SPA-10	6"	2 1/2"	1"	.61"	.64"	—	7/16" Center Bolt
1	SPA-9	6"	2 1/2"	1"	.73"	.77"	—	1/2" Center Bolt
1	SPA-2	6"	3"	1"	.61"	.64"	—	7/16" Center Bolt
1	SPA-3	7"	3"	1"	.73"	.77"	—	1/2" Center Bolt
1	SPA-4	7"	3 1/2"	1"	.73"	.77"	—	1/2" Center Bolt
1	SPA-5	7"	4"	1"	.61"	.64"	—	7/16" Center Bolt
1	SPA-6	7"	4"	1"	.73"	.77"	—	1/2" Center Bolt
2	SPA-7	6"	3"	1"	.77"	.77"	1.56" C/C	1/2" Center Bolt, 2 Holes, Ford
2	SPA-8	6"	3"	1"	.77"	.77"	3.06" C/C	1/2" Center Bolt, 2 Holes, Dodge

Call 800-233-0899 today to place your order.

Jim Musser
Product Manager/Springs

Visit us on the World Wide Web at www.daytonparts.com

Dayton Parts, LLC • PO Box 5795 • Harrisburg, PA 17110-0795 • 800-233-0899 • Fax 800-225-2159
DP/Batco Canada • 12390 184th Street • Edmonton, Alberta T5V 0A5 • 800-661-9861 • Fax 888-207-9064



New Product - Toyota Shackle Kit

Update #2380

Attention: Dayton Parts' Distributors and Business Partners.

Dayton Parts would like to make you aware of new product availability:

Dayton Part Number: 330-412

Toyota Shackle, ref 04483-04040

Used on first generation Tacoma pickup, 1995 1/2 - 2004



Call 800-233-0899 today to place your order.

330-412 Shackle Kit

A handwritten signature in black ink, appearing to read "Earl Rabold".

Earl Rabold
Product Manager/Suspensions

Visit us on the World Wide Web at www.daytonparts.com

Dayton Parts, LLC • PO Box 5795 • Harrisburg, PA 17110-0795 • 800-233-0899 • Fax 800-225-2159
Dayton Parts/Batco • 12390 184th Street • Edmonton, Alberta T5V 0A5 • 800-661-9861 • Fax 888-207-9064

PROUDLY INTRODUCES THE TRISEAL MVP PRODUCT LINE



MVP Leather Series

Triseal MVP[®] Leather Series is the choice of fleet professionals with equipment that operate in harsh, cold environments. The leather sealing lip provides enhanced performance for running in dust and dirt while the two piece design uses a separate wear ring for axles with grooves in the seal journal.

FEATURES

1. Lay down polymer impregnated leather lips performs Better in difficult and harsh conditions. (-65°F, -55°C / 170°F, 77°C)
2. Oversized double-walled, reinforced metal OD and Galvanized inner and outer cases.
3. Additional corrosion proof contaminant exclusion wiper.
4. Standard service and HD Severe Service Sleeves available.
5. Designed for installation with commercial grade tools or Insta-Tool[®] — TRISEAL's patented disposable tools.
6. Meets or exceeds performance and warranty features of Stemco Grit Guard Series.



BENEFITS

1. Out performs nitrile seals in cold and contaminated environments. Performs well with all natural & synthetic oils and greases. Embeddable seal lip absorbs grit.
2. Oversized metal OD directs heat transfer away from lip into hub bore. Galvanized inner and outer cases are corrosion proof and coated with black bore sealant.
3. Additional contaminant wiper – a value added feature not offered by other competitive models.
4. Severe Service sleeve protects the hub from damage during seal removal and provides a new running surface for worn or damaged axle spindles.
5. Seal and sleeve are compatible with competitor's two-piece installation tools. Insta-Tool[®] is perfect for DIY's, service trucks, and small fleets.

Be sure to check out our complete offering of Triseal wheel end products online at www.daytonparts.com



MVP® LEATHER SERIES INTERCHANGE

APPLICATION	INNER BEARING	STANDARD SERVICE	SEVERE SERVICE	COMMERCIAL GRADE TOOL	STEMCO	SKF	NATIONAL
FRONT AXLE SEALS							
9,000# & 12,000# Front Axle, Navistar	H715345	TS69696		TST65078W	382-8056	45103	370131A
12,000# Front Axle, Mack	641 HM212049	TS69628		TST65092W	382-8039	39988	370033A
12,000# Front Axle, Eaton, Ford, Freightliner, Kenworth, Meritor, Navistar, Peterbilt, Volvo GM, Western Star	39581 HM212044 HM212047 HM212049	TS69699		TST65263W	382-8036	35066	370001A
16,000# Front Axle, Ford, Kenworth, Mack, Meritor, Navistar, Peterbilt, Volvo GM, White, Western Star	6461A	TS69697		TST65092W	308-0864	43764	370048A
DRIVE AXLE SEALS							
19,000# Drive Axle, Eaton, Ford, GMC, Navistar, White	594 594A		TS70791	TST65072W	392-9088	45160	370021A
34,000# Drive Axle, Eaton, Ford, Navistar, White	47678 47685 47686	TS69794		TST65052W	392-9099	38780	370023A
34,000# & 38,000# Drive Axle, Mack	580 582		TS70796	TST65272T	392-9094	45099	370022A
38,000# Drive Axle, Eaton, GMC Mack, Meritor	594A 598A		TS70798	TST65065W	392-9132	47690	370005A
38,000#, 46,000# Tandem Axle, Eaton, Ford, Freightliner, Kenworth, Meritor, Navistar, Peterbilt, Volvo GM, Western Star	594 594A 598 598A	TS69799	TS70799	TST65056W	392-9131	47697	370003A
44,000# Drive Axle, Mack	663 HM516449A HM516449C		TS70788	TST65011W	392-9112	42672	370031A
50,000# & 60,000# Mack Drive Axle	687 780	TS69781		TST65030W	392-9089	52664	370069A
TRAILER AXLE SEALS							
19,000# Trailer Axle, Dana, Eaton, Meritor, Standard Forge	663		TS70561	TST65061W	372-7098	40136	370036A
20,000# Trailer Axle, Meritor, Shuler	665A	TS69599		TST65298W	372-7095	43753	370037A
22,500# Trailer Axle, Dana, Eaton, Meritor TN, Standard Forge	HM218248	TS69598	TS70598	TST65060W	372-7097	46305	370025A
22,500# Propar Trailer Axle, Dana, Eaton P-22, Fruehauf, Meritor TP	HM518445	TS69596	TS70596	TST65262W	372-7099	42623	370065A

Visit us at www.daytonparts.com

Dayton Parts, LLC • PO Box 5795 • Harrisburg, PA 17110-0795 • 800-233-0899 • Fax 800-225-2159

Dayton Parts/Batco • 12390 184th Ave. • Edmonton, Alberta T5V 0A5 • 800-661-9861 • Fax 888-207-9064

Dayton Parts, LLC • 6039 Ordan Dr. • Mississauga, ON L5T 2M7

Dayton Parts, LLC • 1605 Lakeway Dr. • Lewisville, TX 75057



PROUDLY INTRODUCES THE TRISEAL MVP PRODUCT LINE



MVP Premium Series

The newest addition to the Triseal product offering provides the longest maintenance free service interval in the industry along with outstanding service performance. With faster error free installation than conventional heavy duty wheel seals, this hand fit series of seals features HNBR (premium nitrile) sealing surfaces on both the ID and OD surfaces, an industry first.

FEATURES

1. Installable with any flat tool, even your hand.
2. Extended temperature ranges down to -40. (-40°F to 310°F) (-40C to 150C)
3. Manufactured with advanced formula HNBR (Hydrogen Nitrile Butadiene Rubber) material on all sealing lips and OD surfaces.
4. Premium sealing lip is protected by four contaminant exclusion barriers.
5. Widest available shoulder coverage in the industry.
6. Meets or exceeds performance and warranty features of CR Scotseal Plus XL, National 38000 Series and Stemco Discover Series.

BENEFITS

1. The combination ribbed rubber OD with piloted installation guide allows for easy, accurate installation to reduced cocked seals.
2. New advanced material extends the service life in extreme temperatures environments including hot starts and braking.
3. Superior contamination prevention system prevents dirt and other debris from causing premature seal failure.
4. Provides superior sealing benefits on damaged and worn axles.
5. Designed to withstand the industry's most demanding vehicle environments.
6. Advanced material provides provide superior performance over a wide range of operating environments.

TRISEAL ULTIMATE SEAL SPECIFICATIONS AND INTERCHANGE

PART NO	APPLICATION	SKF Scotseal Plus	NATIONAL	STEMCO
TS65560	Meritor TN Axle Seal	46304	380025A	373-0243
TS65562	Propar TP Axle Seal	42622	380065A	373-0223
TS65563	Truck Steer Axle Seal	35059	380001A	383-0236
TS65556	Truck Drive Axle Seal	47695	380003A	393-0273

PROUDLY INTRODUCES THE TRISEAL MVP PRODUCT LINE



MVP Unitized Series

Triseal MVP Unitized Series wheel seals are the choice of fleet professionals for superior performance at a very affordable price. The single piece design features NBR (nitrile) sealing lips and metal to metal contact on the OD for superior heat dispersion.

FEATURES

1. Provides widest available shoulder coverage in the industry.
2. Three NBR (nitrile) lip contact barrier points.
(-20°F to 225°F) (-28.8C to 107C)
3. Oversized double-walled, reinforced metal OD.
4. Corrosion proof spacers feature multiple vent holes for enhanced lubrication.
5. Designed for installation with genuine TRISEAL commercial grade tools or Insta-Tool® — TRISEAL's patented disposable tools.
6. Meets or exceeds performance and warranty features of CR Scoteseal Classic, National 37000 Series and Stemco Voyager Series.

BENEFITS

1. Provides superior sealing benefits on damaged and worn axle shoulders.
2. Superior contamination exclusion system prevents seal lip damage and provides excellent temperature range capabilities.
3. Durable, heavy construction provides effective heat transfer away from the sealing lip. Oversized metal OD eliminates spinning or walking of the seal out of the hub bore and includes black bore sealant.
4. Provides free flow of lubricant to the sealing lip and insures a longer, trouble-free service life.
5. Highest volume steer, drive and trailer axle seals are available with low-cost disposable tools to insure proper and effective installation. Great for DIY's and service trucks.



Be sure to check out our complete offering of Triseal wheel end products on-line at www.daytonparts.com



MVP® UNITIZED SERIES INTERCHANGE

APPLICATION	INNER BEARING	UNITIZED SEAL	INSTA-TOOL SEAL KIT (*)	COMMERCIAL GRADE TOOL	STEMCO		SKF	NATIONAL
					GUARDIAN	VOYAGER	SCOTSEAL	STANDARD
FRONT AXLE SEALS								
9,000# & 12,000# Front Axle, Navistar	H715345	65078U		T65078U	308-0856	383-0156	45103	370131A
12,000# Front Axle, Eaton, Ford, Freightliner, Kenworth, Meritor, Navistar, Peterbilt, Volvo GM, Western Star	39581 HM212044 HM212047 HM212049	TS65263U	TS65263UT	TST65263U	308-0836	383-0136	35066	370001A
16,000# Front Axle, Ford, Kenworth, Mack, Meritor, Navistar, Peterbilt, Volvo GM, White, Western Star	6461A	TS65092U		T65092U	308-0864	383-0164	43764	370048A
DRIVE AXLE SEALS								
15,000# Drive Axle, Ford, Meritor F-Series	6559 6580 33287	65111U	TS65111UT	T65111U	309-0935		34387	370047A
19,000# Drive Axle, Eaton, Ford, GMC, Navistar, White	594 594A	65172U		T65172U	309-0964		45160	370021A
34,000# Drive Axle, Eaton, Ford, Navistar, White	5760 47678 47685 47686	TS65152U	65152UT	T65152U	309-0912	393-0112	38780	370023A
38,000# Drive Axle, Eaton, GMC Mack, Meritor	594A 598A	65165U		T65165U	309-0960		48000	370005A
38,000#, 46,000# Tandem Axle, Eaton, Ford, Freightliner, Kenworth, Meritor, Navistar, Peterbilt, Volvo GM, Western Star	594 594A 598 598A	TS65156U	TS65156UT	T65156U	309-0973	393-0172	47697	370003A
44,000# Drive Axle, Mack	663 HM516449A HM516449C	65071U		T65071U	309-0904	393-0104	42672	370031A
50,000# & 60,000# Mack Drive Axle	687 780	TS65030U		TST65030U	309-0948	393-0148	52658	370069A
TRAILER AXLE SEALS								
19,000# Trailer Axle, Dana, Eaton, Meritor, Standard Forge	663	TS65261U		T65261U	307-0713	373-0113	40136	370036A
20,000# Trailer Axle, Meritor, Shuler	665A	65298U		T65298U	307-0744	373-0144	73752	370037A
22,500# Trailer Axle, Dana, Eaton, Meritor TN, Standard Forge	HM218248	TS65060U	TS65060UT	TST65060U	307-0743	373-0143	46305	370025A
22,500# Propar Trailer Axle, Dana, Eaton P-22, Fruehauf, Meritor TP	HM518445	TS65262U	TS65262UT	TST65262U	307-0723	373-0123	42623	370065A

Visit us at www.daytonparts.com

Dayton Parts, LLC • PO Box 5795 • Harrisburg, PA 17110-0795 • 800-233-0899 • Fax 800-225-2159

Dayton Parts/Batco • 12390 184th Ave. • Edmonton, Alberta T5V 0A5 • 800-661-9861 • Fax 888-207-9064

Dayton Parts, LLC • 6039 Ordan Dr. • Mississauga, ON L5T 2M7

Dayton Parts, LLC • 1605 Lakeway Dr. • Lewisville, TX 75057

Wabco Air Dryer Cartridges

Update #2379

Attention: Dayton Parts' Distributors and Business Partners.

Now available from Dayton Parts LLC.

Genuine Wabco air dryer cartridges. We have two part numbers to choose from:

AV432-410-222-7 An OE quality air dryer cartridge at a very competitive price for the aftermarket.
Interchanges with R109994, BA5374, AC1001, AF27817, FLT109994

AV432-901-223-2 An oil coalescing cartridge that provides maximum protection for your vehicle's air system.
Interchanges with R950068

Both are in stock at our Harrisburg, PA and Lewisville, TX warehouses to add to your regular stock order.
Check on-line for pricing at daytonparts.com



**AV432-410-222-7
Air Dryer Cartridge**

**AV432-901-223-2
Air Dryer Cartridge**

Call 800-233-0899 today to place your order.

Steven S. Wolf
Axle Group Product Manager

Visit us on the World Wide Web at www.daytonparts.com

Dayton Parts, LLC • PO Box 5795 • Harrisburg, PA 17110-0795 • 800-233-0899 • Fax 800-225-2159
Dayton Parts/Batco • 12390 184th Street • Edmonton, Alberta T5V 0A5 • 800-661-9861 • Fax 888-207-9064