

Australian Fuelling Systems & Equipment

Fuel Equipment eCatalogue No. 3

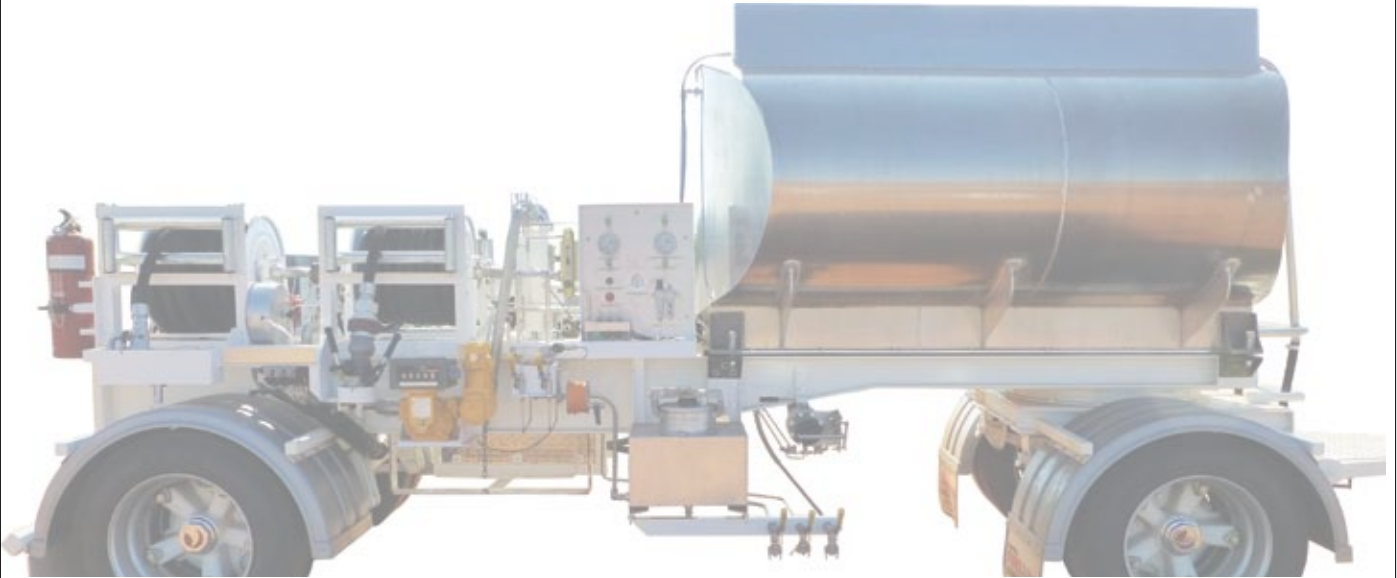

fuelequipment.com

**Custom
Fuelling
Solutions**



Freecall: 1800-025 869 Freefax: 1800-654 732

International phone: +612 6760 7816 Email: sales@fuelequipment.com

7 - 11 Armstrong Street, Tamworth NSW 2340, Australia

Warranty, Parts & Service

Australian Fuelling Systems & Equipment offers comprehensive after sales service, parts supply and warranty to all products and services that we sell. When requesting spares or warranty service please have your purchase details available (Invoice/receipt number and date) as well as make & model details of equipment. We're really big on backing up the products that we sell but not so much doing the same for products from resellers that won't offer after sales service.

We have a dedicated service department with highly trained personnel, two service vehicles and fully equipped workshop for fuel tanker repairs & certifications. We carry out meter calibrations & certifications at retail sites as well as high volume truck meters.

We pride ourselves on knowing our products, how they work and what product will do what you want it to do best. We will also offer guidance on pump/product compatibility and suitability by way of viscosity, pressure and class.



This button will take you to the pertinent product page within our website where more information is available and the ability to download a comprehensive brochure at the "download brochure" tab.

CONTENTS

Filters

Goldenrod 7

Flow Meters

Fill-Rite 6
Piusi 10

Fuel Management 16 - 25

Fuel/Service Trucks 23

Fuel Tankers 22

Helicopter Refuel System 31

Hose reels 6

Nozzles 6 - 27

Pumps

Piusi 12 - 15
Fill-Rite 8 - 9

Tanks

Aviation self-bunded 35

Trailers

Diesel single skinned 16 - 17
Diesel self-bunded 18
Aviation refuelling 20/21 - 32
Dog for Diesel/ULP 19
Service 24

Prices

All prices in this catalogue are valid until stocks are exhausted or until 31st August 2015

If you want quotation for multiple buys or other equipment please call 1800-025 869

Configure your Product

Our website has one awesome advantage - you can choose just what comes with your new pump system - you can pick and choose things like hose length, nozzle type, whether or not you want a flow meter or swivel or filter.....and have the adjusted total price visible to you at all times so that you can make yes or no decisions.

Not everyone's needs are met with the standard issue equipment - in fact we have several pallets of 3.6m delivery hoses that we've had to remove from pumps to fit longer hoses to suit customer's requirements.

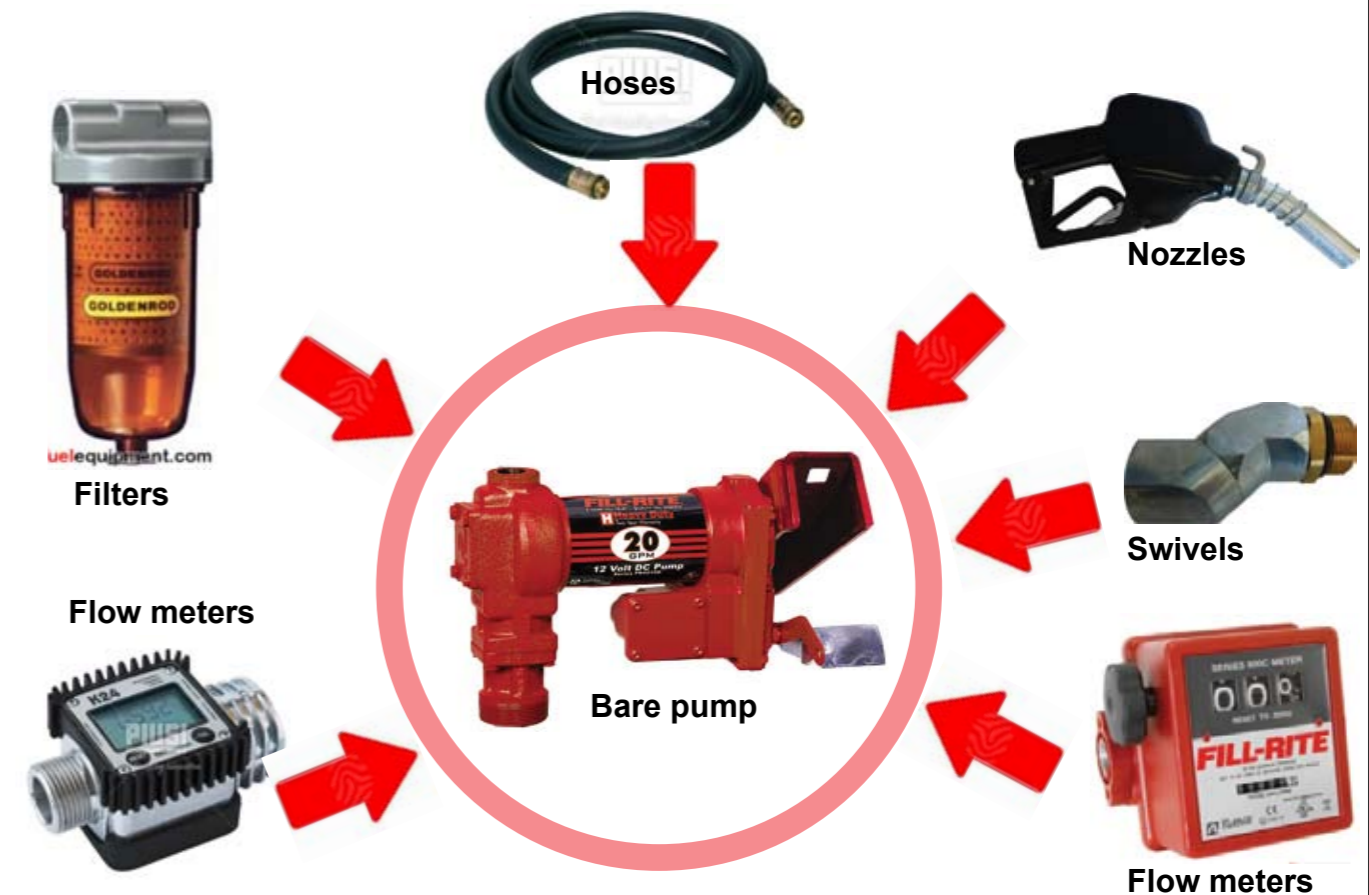

What to do.....within this eCatalogue just click on the button as shown right - this will then immediately start the configuration page showing selectable (and de-selectable) options which can be fitted to the system. You can then choose and unchoose each option to see effect on price. Once you have arrived at exactly what you want - you can then proceed to the checkout and complete the purchase.

Click here to
Configure

Our People

As in any small business - it's the people that make it work. Shown below are the key people within Australian Fuelling Systems & Equipment - these are the people you will interact with in your dealings with us and all will strive to give you the best service possible. All of our people have a wealth of knowledge and experience in our industry as well as in-depth knowhow in their respective fields.



Phil Frear
Aviation Specialist & Design Mgr



Sharyn Dillon
Office Manager



Grant Dewhurst
Business Manager



David Collison
Service Manager



Chris Cameron
Storeman



Grahame Dunn
Draughtsman



Greg Scott
Sales



John Fisher
Workshop Foreman



Andrew Frear
Production Manager



Greg Johnston
Managing Director



This year (2015) marks 27 years in the petroleum fuel equipment industry for us and throughout we have striven to provide the best quality solutions to the many and varied requirements of our customers. We now have a huge range of products, manufacturing facilities, experienced & qualified tradesman with skills and knowledge to provide whatever products and equipment our valued customers require. We take great pride in both the quality of our products as well as the high standards of compliance to best practices within our industry.

Australian Fuelling Systems & Equipment

PO Box 7162 NEMSC 2348 7-11 Armstrong Street Tamworth 2340

Ph: +61 2 6760 7816 Fax: +61 2 6760 7826

www.fuelequipment.com

4

Australian
FUELLING
Systems & Equipment



Australian Fuelling Systems & Equipment

PO Box 7162 NEMSC 2348 7-11 Armstrong Street Tamworth 2340

Ph: +61 2 6760 7816 Fax: +61 2 6760 7826

www.fuelequipment.com

5

Australian
FUELLING
Systems & Equipment

FUELEQUIPMENT.COM

Custom fuelling solutions

Fill-Rite Flow Meters



\$459.00 + GST



Click to Buy

SKU: 050403
Fill-Rite model FR901 38mm
 40mm BSP female connections with removable flanges
 23 - 152 litres per minute flow range.
 Plus/minus 2% accuracy
 Calibration adjusting bypass screw



\$349.00 + GST



Click to Buy

SKU: 050401
Fill-Rite FR806L 25mm Flow Meter
 This model is supplied with integral strainer with removable basket, ideal for overhead tank installations.
 Flow range 23-76 lpm with +/- 1% accuracy
 Max 50 psi pressure 3 digit resettable register, 6 digit non-resettable register.
 25mm (f) ports - Calibration adjusting bypass screw



\$329.00 + GST



Click to Buy

SKU: 050407
Fill-Rite FR807CL 25mm flow meter.
 No strainer for use in pump systems etc.
 Flow range 23-76 lpm with +/- 1% accuracy
 Max 50 psi pressure 3 digit resettable register, 6 digit non-resettable register.
 25mm (f) ports - Calibration adjusting bypass screw

Piusi Hose Reels



\$499.00 + GST



Piusi Hi-Flow Auto Nozzle

Includes Swivel



38mm BSP
 With Swivel
 280 LPM flows

\$499.00 + GST

SKU 113301 Piusi Automatic hose reels for diesel and oil have been designed to ensure high efficiency.

Features:

- Reduced pressure loss
- Corrosion resistant: structure made of stainless steel
- Easy and versatile installation through the rotating support plate and the adjustable arm positions
- Hose stop
- Safety: lateral protective covers

Bare - No hose

SKU 113303 Piusi Automatic hose reels for diesel and oil have been designed to ensure high efficiency.
 Features as per unit at left but fitted with 10m x 25mm delivery hose

10m x 25mm hose fitted

\$839.00 + GST

Australian Fuelling Systems & Equipment

PO Box 7162 NEMSC 2348 7-11 Armstrong Street Tamworth 2340
 Ph: +61 2 6760 7816 Fax: +61 2 6760 7826

www.fuelequipment.com

6

Australian FUELLING Systems & Equipment

FUELEQUIPMENT.COM

Custom fuelling solutions

Aviation Filtration

We carry a wide range of aviation filter systems and replacement elements for many applications - from small 25mm units up to multi-element high flow systems suitable for filtration into storage as well as dispensing. Brands include Facet and Velcon

Parker Velcon

Filtration Solutions for Aviation Fuel Handling
 Velcon Filters manufactures hundreds of different filter cartridges, with a range of filtration efficiencies in a variety of configurations, to meet specific industry standards. This includes a complete line of cartridges qualified to the latest editions of EI specifications (EI 1581, EI 1583 & EI 1590).



VF62 Filter Housing



VF61E Filter Housing

ACO51201L Filter Element



VF31E Filter Housing

ACO21001P Filter Element



VF21SB Filter Housing



CC21-7 Filter Element

Goldenrod Filters

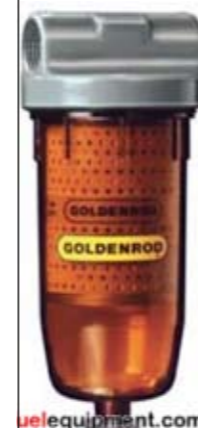

Complete Goldenrod filter with element

SKU: 232901
Goldenrod 495 Filter -
 With 10 micron particulate element
 1" BSP female ports
 Up to 100 lpm, 50 psi
 The ultimate small filter system for small hand & electric pumps, overhead tanks etc. Made in USA

\$69.00 + GST

10 Micron



Click to Buy



with Waterblock element

SKU: 232910
Goldenrod 496 WaterBlock Filter
 The ultimate small filter system for small hand & electric pumps, overhead tanks etc.
 The WaterBlock element fitted absorbs water to capacity and then stops flow of fuel.

\$85.00 + GST

Water Block



Click to Buy



SKU: 232902
4705 10 micron element for the Goldenrod filter.
 These elements fit a wide range of filters incl. Macnaught, National Spencer, Baldwin

\$17.00 + GST



Click to Buy



SKU: 232904
The 496-5 water block element fits the 1" Goldenrod filter housing and provides superior protection from water. 15 micron for particulate removal.

\$25.00 + GST



Click to Buy

Australian Fuelling Systems & Equipment

PO Box 7162 NEMSC 2348 7-11 Armstrong Street Tamworth 2340
 Ph: +61 2 6760 7816 Fax: +61 2 6760 7826

www.fuelequipment.com

7

Australian FUELLING Systems & Equipment

Fill-Rite 240v AC Pumps

Quality, US made pumping & metering equipment fills the requirements of the most arduous applications. Please check our website to enable configuration of this range of pumps to suit your exact requirements - you choose hose length, nozzle type, filter, meter, swivel etc.



\$1899.00 + GST
Bare pump

Hi-Flow
100 LPM

SKU 030425 Model FR310V
With a flow rate few pumps can match, this pump provides long life. Explosion-proof UL listed dual voltage 3/4 HP motor (115 and 230 VAC) Motor has sealed bearings, heavy-duty switch and thermal overload protection Built-in junction box Cast iron pump housing with iron rotor and carbon vanes Check valve, pressure relief valve and strainer assembly, Automatic bypass valve, 2 threaded bung for tank openings. 2 Year Warranty.

Features & Benefits

- Pump only
- 3/4 HP motor
- UL/cUL listed
- Compatible with gasoline, diesel, B20, E-15, and kerosene
- Cast iron construction
- 2 year warranty
- 2 in. threaded bung for tank openings
- Iron rotor with carbon rotary vanes
- Self priming
- Check valve, pressure relief

2 Year
Warranty

Click here to
Configure

Click here to
Buy Bare Pump

fuelequipment.com



\$1099.00 + GST
Bare pump

Flow
76 LPM

SKU 030409 Model: FR700V
This rugged, positive displacement, Heavy Duty pump is UL listed. Explosion proof UL listed 1/3 HP motor (115 VAC-60Hz) with sealed bearings, Heavy Duty switch, thermal overload protection and junction box. Integral check valve with pressure relief on outlet side reduces pressure drop and improves vertical lift. Easy removable strainer, automatic bypass valve, and 2 in. threaded bung for tank openings.

Features & Benefits

- 20 GPM (76 LPM)
- 1/3 HP motor
- UL/cUL listed pump and motor
- Heavy duty cast iron construction
- Diesel, gasoline, kerosene, E15, biodiesel up to B20
- 2 year warranty
- 2 in. threaded base for tank mounting
- Iron rotor with carbon rotary vanes
- Self priming
- Check valve, pressure relief valve, and strainer included

2 Year
Warranty

Click here to
Configure

Click here to
Buy Bare Pump

fuelequipment.com

Fill-Rite DC Pumps

Quality, US made pumping & metering equipment fills the requirements of the most arduous applications. Please check our website to enable configuration of this range of pumps to suit your exact requirements - you choose hose length, nozzle type, filter, meter, swivel etc.



24v Version
Available

2 Year
Warranty

Click here to
Configure

This pump diesel and petrol
fuelequipment.com

Click here to
Buy Bare Pump

Hi-Flow
76 LPM

SKU: 030415
Fill-Rite FR4205 12v DC High flow bare pump. You can purchase it as a bare pump or configure to suit your requirements

The pump features:

- Heavy duty cast iron construction. Capable of 76 litres per minute delivery in standard factory configuration. Note that added equipment will reduce flows
- AusEx approved for Class 3 Flammable Liquids ie ULP
- Vane type pump for easy priming. Has inbuilt bypass valve & suction strainer.
- Nozzle holster.
- Lockable on/off switch.
- Made in USA.
- Limited 2 year warranty

\$599.00 + GST
Bare pump



2 Year
Warranty

This pump diesel only

Click here to
Configure

Click here to
Buy Bare Pump

Hi-Flow
100 LPM

SKU 030445
Fill-Rite FR3204 12v DC Only

With the fastest flow rate of any DC fuel-transfer pump on the market, our FR3200 Series makes filling tanks at remote job sites quicker and more efficient.

Delivering 25 gallons per minute, the FR3200 can fill a 500-gallon tank in just 20 minutes. And because it weighs less than 50 pounds, the FR3200 makes your operation highly mobile. The FR3200 is built strong to provide long-lasting reliability in the most demanding off-road environments. Put it all together, and you'll enjoy less downtime, greater productivity, and a greater return on your efforts.

Features & Benefits

- 25 GPM
- 30 minute duty cycle
- Heavy duty cast iron construction
- Light weight
- Self priming, 12 ft. of lift
- Theft deterrent lockable nozzle
- 2 in. NPT tank adaptor
- 20 ft power cord

\$1199.00 + GST
Bare pump

Piusi Flow Meters



\$189.00 + GST



Click to Buy



\$239.00 + GST



Click to Buy

SKU 053320 K33 Mechanical 25mm Meter
Reliable, economical and easy to install and calibrate on site. Ideal for gravity tank installations
Mod. K33, 3 digit partial totals (max 999 litres), 6 digit totals. 1" BSP fxf

SKU 053325 K24 Digital flow meter. Easy to install, in line or at the end of a delivery pipe,
LCD display: 5-digit partial from 0.1 to 99999, 6 Resettable total available. Flow rate indication. Repeatability 0.2 %. 20 to 120 lpm flows Can be calibrated. Powered by two AAA batteries. 1" BSP mxf

For use with ULP, AvGas, JET-A1



\$549.00 + GST



Click to Buy

SKU 053309 K24 ATEX/IECEx
Meets the ATEX/IECEx requirements - suitable for ULP, AVGAS, JET-A1

Aluminum body. LCD display: 5-digit
20 to 120 lpm flows. Resettable total available.
Flow rate indication. Repeatability 0.3 %. 1" BSP mxf

Pulse output versions available

\$199.00 + GST

High Flow to 220 LPM

\$999.00 + GST



1.5 inch BSP
Ports with
strainer



Click to Buy

SKU 053305 K700 Mechanical
Oval gear mechanical flow meters designed for accurate measuring of the quantity (of fuel) dispensed for medium - high flow rates. These flow meters are reliable, economical and easy to install. .
Flows: 20 to 220 lpm
Accuracy: +/- 1%
Maximum pressure: 10 bar

Australian Fuelling Systems & Equipment

PO Box 7162 NEMSC 2348 7-11 Armstrong Street Tamworth 2340
Ph: +61 2 6760 7816 Fax: +61 2 6760 7826

www.fuelequipment.com

10

**Australian
FUELLING
Systems & Equipment**

400 Litre All-Steel Skid Tank

Newly designed skid tank for diesel - manufactured from laser cut 3mm steel. Includes lockbox for pump which is designed to hold a variety of 12 or 24v pumps depending on flow rate required as well as 6m hose, auto nozzle with swivel and options such as a Goldenrod filter and/or a Piusi digital flow meter. Tank is baffled to minimise surging and fitted with a Catlow Pre-Vent cap.

Lift lugs
Empty lift only

Baffled tank

Cap with pressure
& vacuum vent

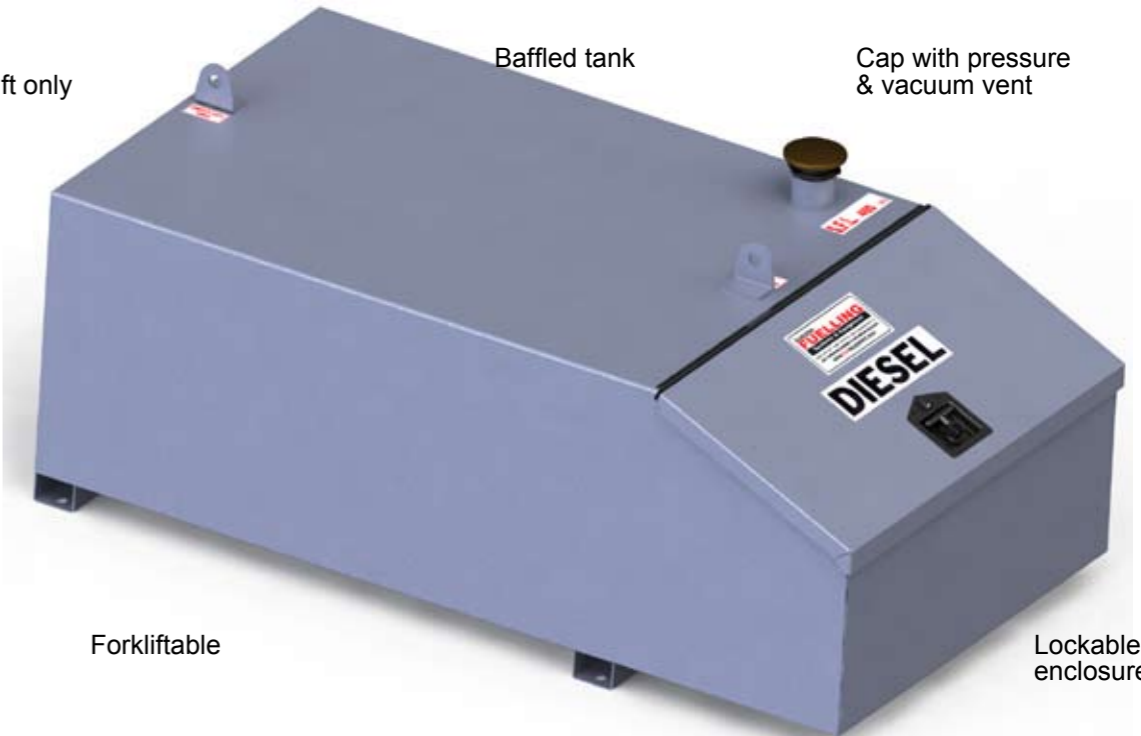

Forkliftable

Lockable Pump
enclosure



NEW

Made from 3mm steel
WON'T wear through
like poly tanks

Prices

Bare tank \$1,299.00 + GST
Tank with pump \$1,799.00 + GST

Includes
Piusi 12v Panther pump
6m rubber delivery hose
Catlow automatic nozzle
Swivel
5m battery cables & clips with inline fuse
Assembled & Tested

Option Prices

Goldenrod 10 micron filter \$179.00 + GST
Piusi K24 digital flow meter \$279.00 + GST
Above installed with all fittings required.
POA for pumps in 24v DC or with higher flow rates and associated equipment available on request.
Dimensions
H: 551mm + lift hooks
W: 806mm
L: 1496mm

**We design and
build tanks for
transport of
fuels - call for
quote or details
on your
requirements**

Australian Fuelling Systems & Equipment

PO Box 7162 NEMSC 2348 7-11 Armstrong Street Tamworth 2340
Ph: +61 2 6760 7816 Fax: +61 2 6760 7826

www.fuelequipment.com

11

**Australian
FUELLING
Systems & Equipment**

Piisi Pumps

Piisi offers a wide range of electric pumps specifically designed for fuel transfer. Our range includes self-priming, CE-certified AC pumps (120/230 V) and DC pumps (12/24 V) DC. Compact and easy to handle, they offer long service life and excellent value for money. Our pumps can be supplied with a wide range of accessories that make them quick and easy to install on any plant. The range of models for diesel fuel consists chiefly of vane pumps, which ensure high flow rates and operating cycles of up to 30 minutes. They are all self-priming and equipped with a ByPass valve to avoid over-pressurisation. The range of pumps for oil includes gear pumps (Viscomat gear), capable of transferring dense fluids at high pressures without damaging the motor. The Visco-Flowmat is a particularly acclaimed model, which switches the pump on and off automatically.



Piisi E120 240v AC Diesel Pump

SKU 033305 Piisi E120 240v Pump
Diesel transfer electric pump. Displacement, self-priming rotary electric vane pumps. 100 LPM bare pump Fitted with by-pass valve and elevated reliability seal even at low working temperatures. Compact and easy to install they are ideal for dispensers, fixed fuel transferring systems and other industrial applications. Suitable for continuous use with thermal motor overload protection.

\$549.00 + GST

Bare pump



Click to Buy

[Click here to Configure](#)



Piisi LP3 240v AC Diesel Pump

SKU: 033334 Piisi LP3 240v Pump
240v AC vane pump with integral by-pass valve for diesel transfer 25mm BSP ports. 45 lpm bare pump. 2m cable & plug 350 watt IP55 protection An inlet strainer is recommended on this pump.

\$249.00 + GST

Bare pump



Click to Buy

[Click here to Configure](#)



Piisi 12v DC Bi-Pump

SKU 033319 BIPUMP 12v DC
Fuel vane pumps. Displacement, rotary vane pumps for transferring diesel fuel, characterised by high flow rates. Available in 12 and 24 Volt versions. Technical features: Vane pump with rotor. By-pass valve incorporated into the pump body. Working cycle of 30 min. Integrated On/Off switch. Flanged 1" connectors.

\$499.00 + GST

Bare pump



Click to Buy

[Click here to Configure](#)

Piisi Pumps



033321 Panther 12v DC Only

SKU 033321 PANTHER DC 12v Only
Transfer pumps. Rotary, self priming, vane pumps featuring high flow rates, and easy operation and installation. Technical features: Vane pump with rotor. Mechanical seal. Incorporated by-pass valve. Connector block with ON/OFF switch. 100 µ filter incorporated in the pump body, easy access for maintenance. Threaded 1" connectors. 56 lpm flows

\$249.00 + GST

Bare pump



Click to Buy

[Click here to Configure](#)



Panther 12 and 24v DC

Dual voltage

SKU 033320 PANTHER DC 12 & 24V
Transfer pumps. Rotary, self priming, vane pumps featuring high flow rates, and easy operation and installation. Technical features: Vane pump with rotor. Mechanical seal. Incorporated by-pass valve. Connector block with ON/OFF switch. 100 µ filter incorporated in the pump body, easy access for maintenance. Threaded 1" connectors. 70 lpm (24v) and 35 lpm (12v)

\$299.00 + GST

Bare pump



Click to Buy

[Click here to Configure](#)

Hi-Volume 24v DC Pump

The Piisi ST 200 high volume diesel pump is available in both 24v DC and 240v ac versions. The DC version is ideal for fitting to refuelling trucks where 24v power supply is available. Can be fitted with a wide variety of accessories including hose reel and hose length to suit, auto nozzle, swivel, flow meter, filter etc. Call 1800-025 869 for further information if required.



Piisi ST200DC 24v DC Pump Bare

SKU: 033308 Piisi ST200DC
High flow 24v DC portable diesel pump. ST200DC dispenses diesel fuel at a rate of up to 185 lpm. This is a bare pump - click the "customise" button below to select a range of optional accessories to kit this pump to suit your required application. Duty cycle of 25 minutes ON and 12 minutes OFF Power supply - 24v DC Supplied with 6m heavy duty cable & clips On/Off switch

\$1995.00 + GST

Bare pump



Click to Buy

Piusi Pumps



033360 Piusi Viscomat 90

SKU 033360 VISCOMAT 90 240v
Electric vane pump for pumping fluids of a viscosity up to 500 cSt. Continuous operations, with elevated suction, up to 6 bar pressures. Noise levels below 70 dB. Optional closed-delivery operations thanks to inbuilt adjustable by-pass in pump body. Sintered steel rotors with resin vanes. Flows to 50 LPM

\$699.00 + GST

Bare pump



033336 Nala Cube 45

SKU: 033336 Nala Compact 45
Complete 240v diesel transfer station - compact unit for easy installation on onground tanks, drums or can be wall or pedestal mounted. This a run-out system, limited stocks available. Download PDF Brochure
4m hose with automatic shutoff nozzle
3 digit flowmeter with reset & non-reset totalisers
45 lpm delivery
In cabinet with on/off switch
350w motor

\$499.00 + GST

Bare pump



Click to Buy



033337 Piusi Cube 56

SKU 033337 Piusi CUBE 56
Diesel fuel dispenser for non commercial use. Sturdy structure designed for different applications: can be fixed to walls, tanks cisterns, drums, special pedestals. Self-priming vane pump fitted with bypass, installed on anti-vibration supports. Mechanical seal. Induction motor fitted with thermal motor overload protection. Automatic nozzle with swivel connection. Integrated nozzle holder with stop/start pump lever. Intake mesh filter. Nutating-disk flow meter

\$749.00 + GST

Bare pump



Click to Buy



033338 Piusi Cube 70

SKU 033338 Piusi CUBE 70
Diesel fuel dispenser for non commercial use. Sturdy structure designed for different applications: can be fixed to walls, tanks cisterns, drums, special pedestals. Self-priming vane pump fitted with bypass, installed on anti-vibration supports. Mechanical seal. Induction motor fitted with thermal motor overload protection. Automatic nozzle with swivel connection. Integrated nozzle holder with stop/start pump lever. Intake mesh filter. Nutating-disk flow meter

\$899.00 + GST

Bare pump



Click to Buy

Australian Fuelling Systems & Equipment

PO Box 7162 NEMSC 2348 7-11 Armstrong Street Tamworth 2340

Ph: +61 2 6760 7816 Fax: +61 2 6760 7826

www.fuelequipment.com

14

**Australian
FUELLING
Systems & Equipment**

Piusi Pumps



\$1999.00 + GST

SKU 033339 CUBE 70 MC

Diesel fuel dispenser for non commercial use. Sturdy structure designed for different applications: can be fixed to walls, tanks cisterns, drums, special pedestals. Self-priming vane pump fitted with bypass, installed on anti-vibration supports. Mechanical seal. Induction motor fitted with thermal motor overload protection. Automatic nozzle with swivel connection. Integrated nozzle holder with stop/start pump lever. Intake mesh filter. Fitted with oval gear meters and an electronic unit for multiuser control and pre-selected dispensing. Local memory capable of storing data for last 255 operations. Interfaces with PC for sending and organising data. Possibility of entering vehicle registration number, kilometres, date and time of dispensing operation. Magnetic keys (Kit keys) available for user identification. On request: a dedicated software for printing individual summaries of dispensing details.



\$2299.00 + GST

SKU 053312 MC BOX MANAGEMENT SYSTEM

Multi-user control panel with accessories for PC connection. MC BOX permits: Pump ignition, identification of authorised users, Pre-selection of dispensed quantity, Management of pulse meter, Management of an external switch to switch off pump at minimum level, Management of micro switch connected to nozzle support, Connection to an external printer. Technical features: Panel with dual display, keyboard and i-button reader. Controls up to 120 users through passwords or i-button keys. Calculates consumption of each individual user. Local memory up to last 255 operations. Possibility of inserting vehicle registration number, kilometres, date and time of dispensing. Dedicated software for printing individual detailed summaries. Possibility of managing up to 16 panels with one software. Key reader with USB socket for exporting data. RS converter with USB socket for direct connection with PC via cable up to 1000 metres.



\$2999.00 + GST

SKU 033325 CUBE 70 MC 2.0 with MANAGEMENT SYSTEM

Cube 70 MC 2.0 is equipped with a standard LAN connection to allow constant dialogue with the software, receive configuration mode data from a remote location and transmit fuel delivery reports. The 2.0 product range requires the use of Self Service Management 2.0 software. Cube 70 MC 2.0 can be installed directly on the tank, on a wall or on a pedestal. It's the ideal product for those seeking practicality and the maximum safety in diesel fuel dispensing procedures. The mechanical component of Cube 70 MC 2.0 features:

- High displacement self-priming vane pump.
- Automatic nozzle with swivel fitting.
- Integrated nozzle holder with pump start/stop lever.
- Pump suction mesh strainer.
- Oval gear electronic flow meter

Optional equipment:

- PW-WiFi to switch to a wireless connection.
- magnetic keys (yellow i-button) for user recognition
- magnetic keys (blue i-button) for vehicle recognition.
- OCIO 2.0 level indicator for constant monitoring of tank levels



Australian Fuelling Systems & Equipment

PO Box 7162 NEMSC 2348 7-11 Armstrong Street Tamworth 2340

Ph: +61 2 6760 7816 Fax: +61 2 6760 7826

www.fuelequipment.com

15

**Australian
FUELLING
Systems & Equipment**

Diesel Trailers Utility 1000L and 2000L

Australian Fuelling Systems now supply a range of utility diesel fuel trailers. These trailer are made with the same tank & high quality construction that 27 years of manufacturing experience provides. The standard trailer is not fitted with the usual fire extinguisher & bracket, spill kit, lockable storage box, 15" tyres etc but these can be optionally added if required at extra cost. Available in 1000 litre and 2000 litre capacities in both registerable and unregistrable versions.



Brakesafe 6000



80mm lockable fill and vent with shutoff valve



LED Lights



Dual safety chains

Features

- Dual safety chains with rated shackles
- Brakesafe 6000 series breakaway unit
- Provision for front or top mounted pumps
- All-steel baffled tank with 5 year limited warranty
- Calibrated dipstick of 20x20mm anodised aluminium
- 3 Tonne rated load sharing suspension
- New Landcruiser pattern 6 stud rims
- LED lights
- 50mm axles
- Electric brakes (10") on all hubs
- 12 pin electrical plug
- Provision for hose reel mounting
- New 14" tyres
- All steel vehicle frame
- 3500kg ball tow hitch

This trailer can be fitted with a wide range of options to suit your specific requirements. These include spill kit, lockable tool/utility box, fire extinguisher, spare tyre & bracket as well as whatever pumping equipment is required.

Call 1800-025 869 or email sales@fuelequipment.com for quote or information.

Australian Fuelling Systems & Equipment

PO Box 7162 NEMSC 2348 7-11 Armstrong Street Tamworth 2340
Ph: +61 2 6760 7816 Fax: +61 2 6760 7826

www.fuelequipment.com

16

**Australian
FUELLING
Systems & Equipment**

Diesel Trailers Utility 1000L and 2000L



**1000L Reg'ble
\$6749.00 + GST**

**2000L Reg'ble
\$8495.00 + GST**

Utility Trailers

Inv No	Model	Reg	SFL Level	Dimensions
410005	1000L Utility	Reg'ble	1000 litres	3150Lx2020Wx1560H
410006	1000L Utility	Unreg'ble	1000 litres	3150Lx2020Wx1560H
410007	2000L Utility	Reg'ble	1950 litres	4330Lx2020Wx1560H
410008	2000L Utility	Unreg'ble	1950 litres	4330Lx2020Wx1560H

Options

Spill kit				All quipment & workmanship fitted to these trailers are covered by 12 months warranty with additional 4 years (total 5 years) warranty on the tank. Warranty is limited to repair or replacement at our discretion and excludes normal wear & tear and physical damage caused by accident or neglect or other third party causes. No responsibility is accepted or implied for any consequential, third party damage or loss of product.
Lockbox lockable				
Extinguisher 9kg & bracket				
Pump lockbox - DC pump				
Engine powered dispenser system				

Warranty

About us:

We've been building fuel trailers in Tamworth, NSW, using Australian craftsmen & materials since the late 1980's - we made many mistakes, but after the first fifteen years we got to the stage where we believe we get most things right. We have designs & models for a whole range of fuel & oil handling trailers - these range from aviation refuellers, waste oil collection, special transformer oil vehicles, dog-type trailers with capabilities & volumes up to 10,000 litres for carriage of Class 3 Flammable Liquids.

Australian Fuelling Systems & Equipment

PO Box 7162 NEMSC 2348 7-11 Armstrong Street Tamworth 2340
Ph: +61 2 6760 7816 Fax: +61 2 6760 7826

www.fuelequipment.com

17

**Australian
FUELLING
Systems & Equipment**

Self-Bunded Diesel Fuel Trailers



Australian designed & manufactured

A solution for transporting and dispensing fuel to machinery & equipment in environmentally sensitive areas, these trailers incorporate strategies and systems to minimise the risk of both accidental and operational spillage of diesel fuel. The solid dual-walled tank construction, spill collection sumps and integral protective equipment provides a well balanced and economical fuelling system when risk of spillage needs to be minimised.



Features

- Dual-wall tank construction
- Outer tank will contain 110% of inner tank
- Interstitial space monitor
- Rollover protection coaming with lockable & weatherproof cover
- Pressure & vacuum vent with rollover valve (closes valve if tank inclines greater than 60deg)
- All fluid out is via an anti-siphon valve
- Spill containment at fill and pump locations (both fitted with drain valves)
- Lockable enclosures secures all pumping equipment and fill/dip points
- Spill kit and 9kg fire extinguisher included
- Lockable tool/equipment box standard
- Choice of engine-powered or DC pump systems

Australian Fuelling Systems & Equipment

PO Box 7162 NEMSC 2348 7-11 Armstrong Street Tamworth 2340
Ph: +61 2 6760 7816 Fax: +61 2 6760 7826

www.fuelequipment.com

18

Australian
FUELLING
Systems & Equipment

Dog Trailers

Australian Fuelling Systems & Equipment manufactures dog-type trailers for transport of diesel, unleaded petrol, aviation fuels, kerosine and other compatible fluids. We also specialise in fitting all required dispensing equipment, including to NMI requirements for resale of product, loading systems with overfill protection and built to comply with requirements of AS2809 1 & 2 Road Tank Vehicles for Dangerous Goods - Road Tank Vehicles for Flammable Liquids. All systems are thoroughly wet tested prior to despatch.



A 10,000 litre dog trailer with three compartments. Equipped with Scully bottom fill overfill protection system and all requirements of AS2809 1 & 2 to enable licensing and registration as a Dangerous Goods Vehicle.

- Features:**
- Compliant to AS2809 1 & 2
 - Bottom fill with API adaptors
 - EBS braking
 - Pneumatic safety rails
 - Standalone hydraulic power pack
 - Dual hydraulically powered pumps
 - Vapour recovery system
 - Pneumatic internal valves
 - Calibrated dipsticks
 - Available in single, dual or triple compartment versions
 - Rear carry tray for drums & equipment
 - HazChem library system

Compliant to AS2809 with all requirements for registration as Dangerous Goods vehicle



Close-up of dual product, hydraulically powered dispensing system. Each system with 25mm automatic nozzle as well as 40mm bulk outlets which bypasses the meters/reels. Scully-type overfill protection system



Tank walkway showing hatch systems, vapour recovery fittings and pneumatic safety railing.



Yanmar diesel engine-powered hydraulic power pack makes this vehicle a complete stand-alone fuelling system.

Got a question?
Need a quote?

Call 1800-025 869 or
email sales@fuelequipment.com

www.fueltrailer.com

Refuelling Trailers for Class 3 Flammable Liquids with Dangerous Goods Approvals

Designed and built with all requirements to allow registration as a Dangerous Goods Vehicle allowing transport of Class 3 Flammable Liquids on public roads. These vehicles are built in compliance to AS2809 1 and 2 and can be fitted with either DC or engine-powered dispensing systems. Available in 1000, 1500 and 2000 litre capacities. For larger capacities please call. These vehicles are mainly used for onsite refuelling of aircraft but are also suitable for transport of petrol for a multitude of uses.



Complete standalone compliant aviation refuellers for safe remote operations

Australian designed & manufactured

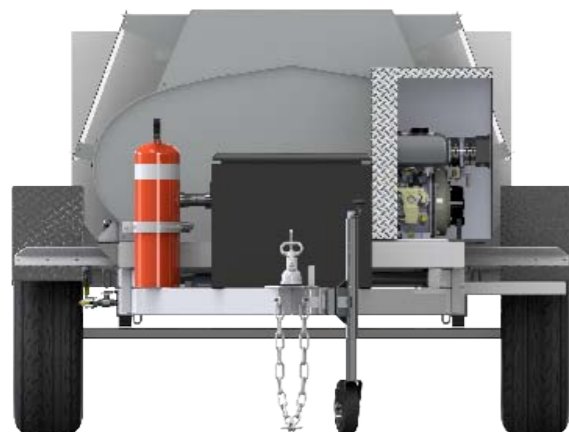

Suitable for Class 3 Flammable Liquids including:

- ULP/PULP
- AvGas
- Jet-A1
- Kerosene
- Mogas
- Solvents

Fully self-contained

The vehicle is equipped to operate in remote locations and all required equipment is built-in. Supplied with all requirements for Dangerous Goods Vehicles including:

- Spill kit
- First aid kit
- Traffic warning triangle signs
- Flameproof torch

Australian Fuelling Systems & Equipment

PO Box 7162 NEMSC 2348 7-11 Armstrong Street Tamworth 2340
Ph: +61 2 6760 7816 Fax: +61 2 6760 7826

www.fuelequipment.com

20

**Australian
FUELLING
Systems & Equipment**

Refuelling Trailers for Class 3 Flammable Liquids

Versions available

- 1000 litres
- 1500 litres
- 2000 litres

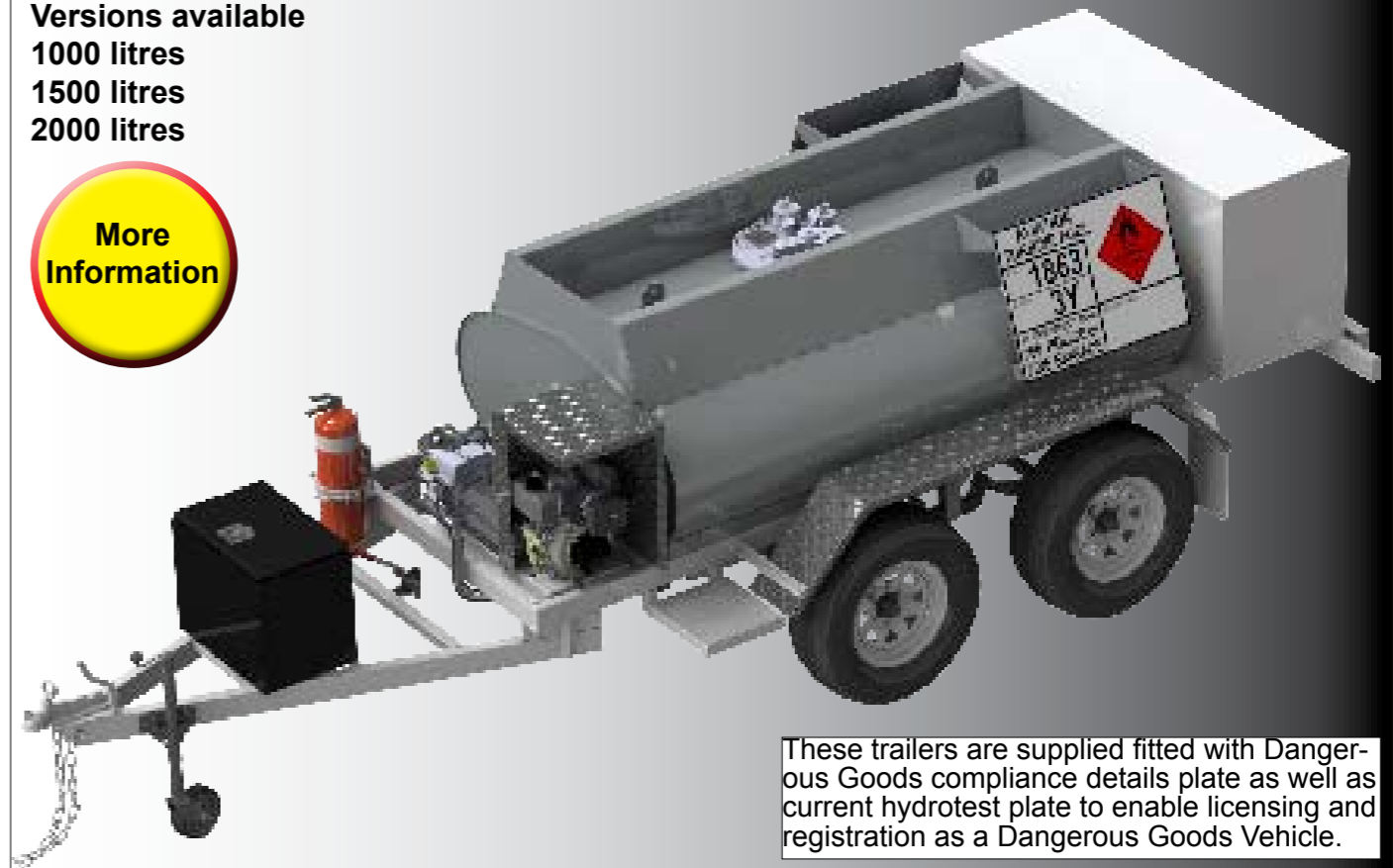

These trailers are supplied fitted with Dangerous Goods compliance details plate as well as current hydrotest plate to enable licensing and registration as a Dangerous Goods Vehicle.



Rear view of trailer

Tanks

- Tanks are constructed of 5mm aluminium plate and have the following features:
- Fitted with outlet elbow with internal valve and manual top operator.
- Fitted with Treloar MC402 hatch system incorporating pressure & vacuum vent with rollover protection valve, emergency vent, inspection hatch and 80mm fill & dip points with lockable Kamlok caps.
- Water collection sump with drain line & valve.
- Supplied with calibrated dipstick (with NMI certification if required at extra cost)
- Mounted to trailer frame with spring-loaded brackets.
- 2 x baffles with man access ports in each.
- Fitted with lift points (empty lift only)

Australian Fuelling Systems & Equipment

PO Box 7162 NEMSC 2348 7-11 Armstrong Street Tamworth 2340
Ph: +61 2 6760 7816 Fax: +61 2 6760 7826

www.fuelequipment.com

21

**Australian
FUELLING
Systems & Equipment**

Fuel Tankers

Designed and constructed to suit just about any application, our tankers are used for industry, mine sites, civil construction, transport, fuel distributors, aviation, in fact, anywhere that large machinery needs to be kept on the move. Pumping and metering systems for resale or in-house use.



10,000 litre tanker with hydraulically powered dispensing system. Fitted with equipment to refuel standard top-fill vehicles and machinery as well as rapid filling of "quick-fill" equipped plant via Wiggins automatic nozzle. The tank is equipped with overfill protection system and can be "self-filled" by the onboard pump and Wiggins nozzle without any need to access tank top. Rear tray can be sized to carry drums, pallets & other required equipment.



Hydraulically powered pump-set with Ebsray V20 vane pump, Macnaught flowmeter with industrial register and 50mm high flow outlet.

Rear view showing rear carry tray and access to tank top fittings. Vehicle equipped with HazChem library system for product identification.

Service Trucks

Small service/fuelling truck custom designed with pneumatically operated diesel and oil dispensing systems. The diesel system is equipped with both standard "top-fill" nozzle with hose reel as well as a Wiggins "quick-fill" nozzle. New oil dispensing, waste oil collection and a small crane completes this unit.



Side view of unit showing oil, fuel & air reels, safe access steps & small crane.



Hydraulically powered air compressor



Oil/air/coolant dispensing reels



Multi-compartment oil tanks



Tank bottom fill connection adaptor.



Wiggins "quick-fill" nozzle



Dual diesel reels



Small hydraulic crane & rugged rear bumper

Service Trailers

Our service trailers have all requirements to allow complete, safe & clean oil changes and top-ups, waste oil collection, storage & discharge, greasing, provides air power for pumps, air tools & tyre inflation, on-board power with solar recharging for electric start compressor as well as work lights. Safe & clean stowage of used oil filters - with any drainage emptied into main waste oil tank.



More Information

Australian designed & manufactured

Features - standard unit

- High quality tri-cylinder cast iron compressor with electric start petrol engine - 17cfm
- Air reel with snap-on fitting
- Waste oil system with remote collection
- Used filter drain bin
- Greasing - with K53 air cartridge gun
- 2 x new oil systems with reels & digital metering
- 1 x 200 litre stainless water or coolant tank
- Heavy duty vehicle with tandem axles, LC hubs
- Lockable storage cabinets
- Solar input to compressor start battery
- White 2 part epoxy enamel finish (custom colours optional at extra cost)
- Steps for access to tank top for fill & dip
- Aluminium guards for vehicle front and pumps
- Steel oil & waste oil tanks with spring-loaded mounts.
- Calibrated dipsticks
- Multiple air outlets for tools etc
- LED vehicle lights
- Removable spill trays
- Quality Macnaught 5:1 oil pumps
- Pneumatic double diaphragm pump for waste oil
- 9kg fire extinguisher & bracket
- Spill kit

Standard tank configuration - 2 x 200L new oils, 1 x 400L waste oil and 200L stainless water or coolant tank.

Australian Fuelling Systems & Equipment

PO Box 7162 NEMSC 2348 7-11 Armstrong Street Tamworth 2340
Ph: +61 2 6760 7816 Fax: +61 2 6760 7826

www.fuelequipment.com

24

Australian
FUELLING
Systems & Equipment

Piusi Hi-Volume 24v DC Pump

The Piusi ST 200 high volume diesel pump is available in both 24v DC and 240v ac versions. The DC version is ideal for fitting to refuelling trucks where 24v power supply is available. Can be fitted with a wide variety of accessories including hose reel and hose length to suit, auto nozzle, swivel, flow meter, filter etc. Call 1800-025 869 for further information if required.



SKU: 033308 Piusi ST200DC

High flow 24v DC portable diesel pump. ST200DC dispenses diesel fuel at a rate of up to 185 lpm. This is a bare pump - click the "customise" button below to select a range of optional accessories to kit this pump to suit your required application. Duty cycle of 25 minutes ON and 12 minutes OFF. Power supply - 24v DC. Supplied with 6m heavy duty cable & clips. On/Off switch

\$1995.00 + GST

240v AC version available



Click to Buy

Piusi Fuel Management System



MC BOX SYSTEM

Multi-user control panel with accessories for PC connection. SKU053312. MC BOX permits: Pump start-up, identification of authorised users, Pre-selection of dispensed quantity, Management of pulse metre, Management of an external switch to switch off pump at minimum level, Management of micro switch connected to nozzle support, Connection to an external printer. Technical features: Panel with dual display, keyboard and i-button reader. Controls up to 120 users through passwords or i-button keys. Calculates consumption of each individual user. Local memory up to last 255 operations. Possibility of inserting vehicle registration number, kilometres, date and time of dispensing. Dedicated software for printing individual detailed summaries. Possibility of managing up to 16 panels with one software. Key reader with USB socket for exporting data. RS converter with USB socket for direct connection with PC via cable up to 1000 metres.

\$2299.00 + GST

Includes software download kit with CD software, 10 user keys, Mgr key, serial plug reader. DOES NOT include pulse flow meter

Australian Fuelling Systems & Equipment

PO Box 7162 NEMSC 2348 7-11 Armstrong Street Tamworth 2340
Ph: +61 2 6760 7816 Fax: +61 2 6760 7826

www.fuelequipment.com

25

Australian
FUELLING
Systems & Equipment

FUELEQUIPMENT.COM

Custom fuelling solutions

Single Skin Stainless Aviation Fuel Tanks

A range of conventional single skin aviation tanks from 2500 to 50,000 litres. Constructed of Grade 304 stainless steel, these tanks offer virtually maintenance free operation in almost any environment. Built with all required features for safe, compliant use with aviation fuels. Available painted or unpainted. Signage supplied but not fixed for transport.



Made from Grade 304 stainless steel

20,000 litre tank with 240v dispenser system with 20m hose, filtration & flowmeter

Elliptical Stainless Aviation Tanks

Cylindrical Stainless Aviation Tanks



5000 Litre



5000 Litre

- 5000 litre capacity, elliptical or cylindrical tanks for aviation fuel.
- 30:1 sloped tank floor
- Collection sump with stainless drain valve
- 600mm man access hatch
- 9kg fire extinguisher & bracket
- All statutory signage

- Stainless discharge valve 40mm
- Calibrated dipstick
- All welds passivated
- 270mm inspection hatch
- Riser pipes for vents to 4m from ground
- Forklift pockets
- Wide range of dispenser sets available

aviationfueltanks.com

Australian Fuelling Systems & Equipment

PO Box 7162 NEMSC 2348 7-11 Armstrong Street Tamworth 2340

Ph: +61 2 6760 7816 Fax: +61 2 6760 7826

www.fuelequipment.com

26

Australian

FUELLING

Systems & Equipment

FUELEQUIPMENT.COM

Custom fuelling solutions

Automatic Nozzles



\$99.00 + GST

NB - automatic nozzles will NOT work on gravity systems

SKU: 043001
Catlow automatic 3/4" nozzle for ULP
Yellow PVC cover
BSP threads
One-hand hold-open mechanism for effortless operation
Full scuff-guard protects the nozzle and vehicle while insulating the user's hand
Replacement spout kits available.
Splash shield included



\$99.00 + GST

NB - automatic nozzles will NOT work on gravity systems

SKU: 043002
Catlow automatic 3/4" nozzle for diesel/leaded. Black PVC cover
Features
BSP threads
One-hand hold-open mechanism for effortless operation
Full scuff-guard protects the nozzle and vehicle while insulating the user's hand
Replacement spout kits available.
Splash shield included



\$199.00 + GST

SKU: 043003
Catlow Max-1 high flow diesel nozzle. Black PVC cover. Made in USA
Features
One hand hold-open mechanism for effortless operation
Spout replacement kits available
Up to 208 lpm delivery



\$129.00 + GST

SKU: 043009
Catlow N1AF Automatic Farm Nozzle - 25mm BSP inlet
Features
Specially designed poppet & check valves reduces pressure drop. High flow rates - up to 80 lpm. Automatic shutoff prevents overfilling
Made in USA

Small Trailers for Class 3 Flammables

Ideal for helicopter & boat refuelling, these small trailers can be equipped with manual or DC powered dispensing systems.

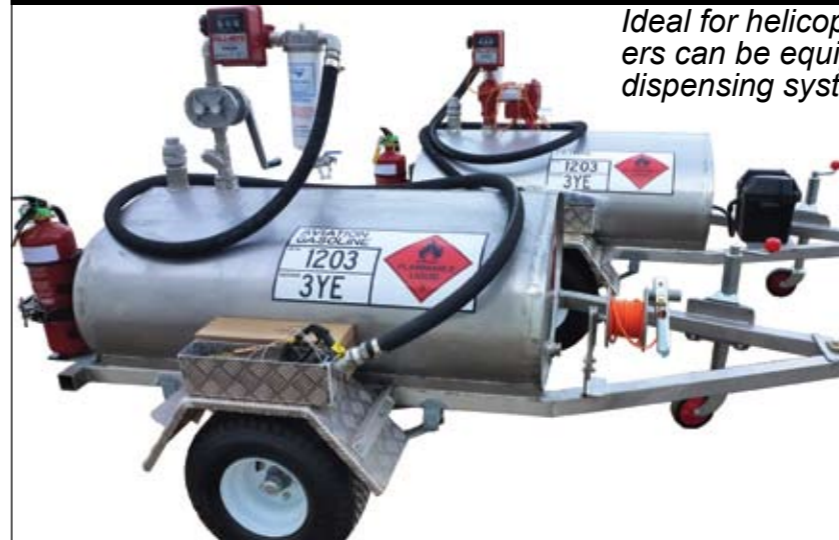

Small size makes them ideal for use on marinas and other areas where space is at a premium. These units can be custom built to suit any application.

Options which can be fitted include:

- Solar power system
- Hose reel
- Flow meter
- Filtration - standard or for aviation
- Ball or ring type tow hitch
- Can include all requirements for registration - up to maximum 400 litres.
- Spare tyre
- Static reel

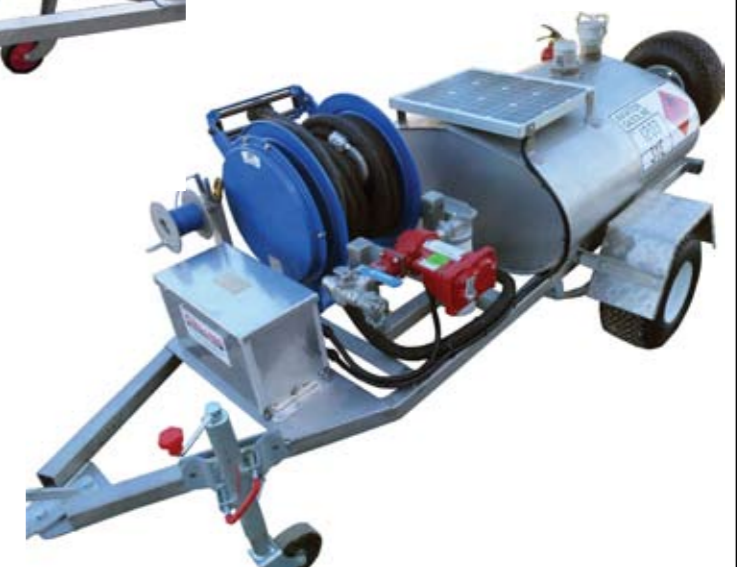

Australian Fuelling Systems & Equipment

PO Box 7162 NEMSC 2348 7-11 Armstrong Street Tamworth 2340

Ph: +61 2 6760 7816 Fax: +61 2 6760 7826

www.fuelequipment.com

27

Australian

FUELLING

Systems & Equipment

12/24v DC & Manual aviation refuel Pumps

Australian Fuelling Systems & Equipment can design, build & supply a solution for in-the-field refuelling of your small aircraft - whether by 12 or 24v DC or manual systems. Pumps can be configured for use with drums, tanks or IBC's with your choice of nozzle, filtration, hose length, flow meter & static cable.

Fill-Rite



Fill-Rite 12 or 24v DC Pumps modified for use with aviation fuels. Can be configured with a wide range of equipment to suit almost any application.

Manual



High quality Japanese made geared rotary pump can be built up to suit most applications. With Velcon filter, stainless fittings and either aluminium or stainless suction tubes. This unit can be made to be fully sealable with Kamlocks for transport within the aircraft.

Carts



Custom built refuelling carts. Can be fitted with manual or DC pumps. Can be fitted for manual tow or use with any kind of tug vehicles.



Fill-Rite 12 or 24v DC Pumps built into a transportable frames for easy connection to supply tank.



300 Litre Trailer - with manual dispenser pump, spring rewind reel, filtration & nozzle.



We custom design and build aviation fuel transfer pumps.

Miscellaneous Equipment

Australian Fuelling Systems & Equipment can design, build & supply a solution for in-the-field refuelling of your small aircraft - whether by 12 or 24v DC or manual systems. Pumps can be configured for use with drums, tanks or IBC's with your choice of nozzle, filtration, hose length, flow meter & static cable.

Nozzles



Elaflex ZVA ZVF25
25mm over wing nozzle with quick detach spout, conical strainer basket, spout cap & static lead with clip and plug.



The Liquip AVN042 has been designed as an easily operated nozzle for (overwing) delivery of aviation fuels. Unlike normal nozzles, it is equipped with "power assist" dashpot operation, making it as light as a service station bowser nozzle. The body, handle and trigger are made from heavy duty, lightweight aluminium.



Eaton's Carter product line includes a number of underwing refueling nozzle models suitable for the widest range of applica-

Hose Reels



Macnaught
Spring powered rewind
Up to 20m's x 25mm hose. 316 stainless flow path. 25mm (f) in & 25mm (m) out.



The Liquip
Available in 300mm, 450mm and 600mm widths.
Geared manual rewind or hydraulic
38mm inlet/outlet
Nickel coated flow path

Swivels



Swivels
Range of mxf swivels available to suit whatever nozzle is fitted

Static Reels



Manual and spring rewind static reels with clips.
Pressure Gauges



Pressure and pressure differential gauges to manage filter element status and management.

Drum suction spears



Drum spears
Drum spears with various options can be supplied - including Kamlok connections, hose attached for closing into a sealed loop for dust free transport. Includes drum bung adaptor.

Water & Gauge Paste



We stock Kolor Kut water finding and gauging paste.



Fill-Rite DC Aviation Fuel Pump

Fill-Rite 12 and 24v DC pumps fitted for use with aviation fuels. A range of optional suction and delivery hoses, nozzle and static cable completes the system. Pumps are modified to ensure there is no "red metals" (brass, bronze, gun metal) in the flow path. Pump has AusEx approval for use with Class 3 Flammable Liquids.

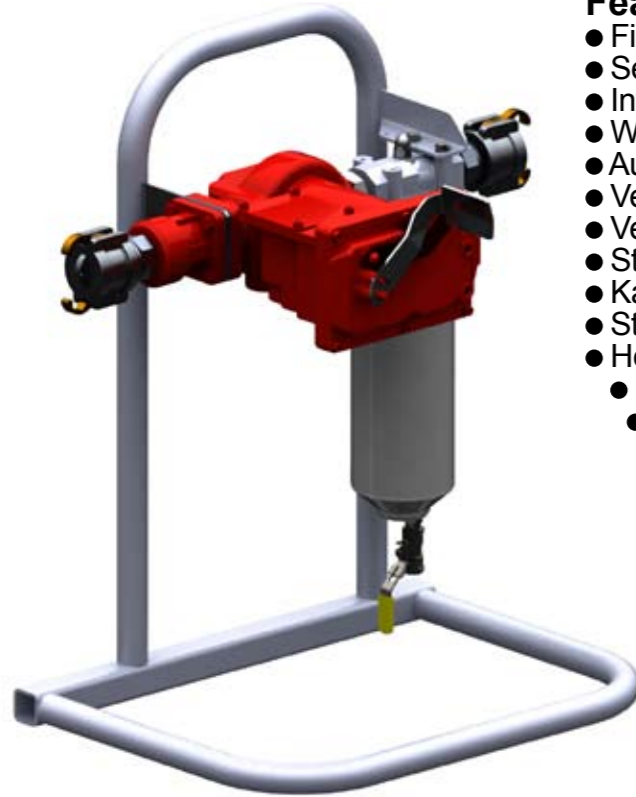

Features

- Fill-Rite 12 or 24v DC pump
- Self-priming positive displacement
- Integral bypass valve
- With on/off switch
- AusEx Approved for use with Class 3 Flammable Liquids
- Velcon VF31E filter housing
- Velcon ACO21001P element
- Stainless ball valve for sample/draining
- Kamlok suction & delivery fittings with chained dustcaps
- Stainless fittings
- Heavy duty galvanised pump frame
- Static cable & clip
- No "red" metals in flow path
- Convenient Kamlok connections

Flow Rate

The base pump has a delivery rate of 76 lpm - the addition of accessories will reduce this flow rate. A typical setup of Velcon filter, 6m x 25mm hose, Elaflex VF25 nozzle and digital flow meter will deliver approximately 50 lpm. Obviously, longer delivery hose and/or hose reel will reduce this flow.

Electrical

Please note that we do not supply these pumps with electrical wiring - it is the owners responsibility to ensure electrical connection is made in accordance with AS3000 for Class 1 Hazardous Zones by a suitably qualified person

Dimensions

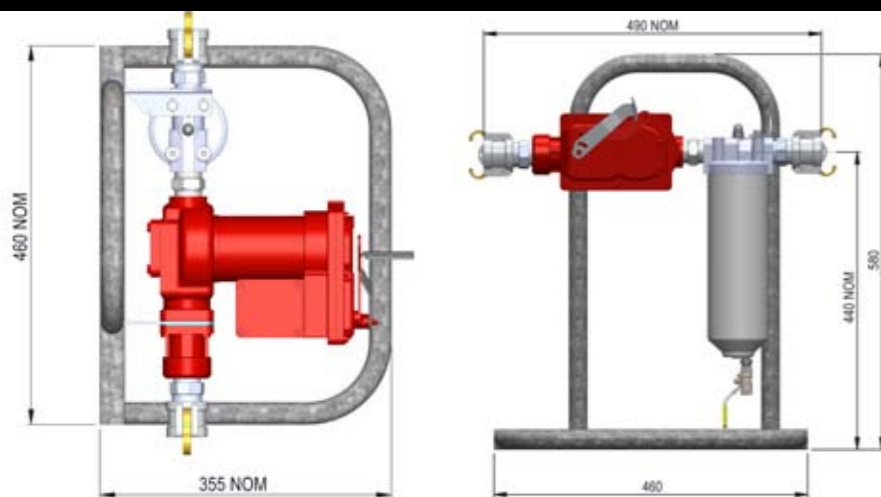

Options

To allow this pumpset to fit your requirements, a wide range of options are available to suit:

- 1) Suction hose assemblies
- 2) Drum or tank spears
- 3) Delivery hose assemblies
- 4) Nozzle
- 5) Flowmeter

Please go to www.fuelequipment.com and click the "customise" button on this product to configure the system to suit your application

12v DC Cat# 030480
24v DC Cat# 030481

Call 1800-025 869 or email sales@fuelequipment.com for more details

Helicopter refuelling system

Complete helicopter fuel storage & refuelling system built and installed by Australian Fuelling Systems & Equipment. With a 35,000 litre self-bunded tank, on-demand pump system, underground stainless piping supplying fuel to hydrant pits and a mobile hydrant cart, this system provides the ultimate in safe, convenient, clean & dry refuelling. Built to service the needs of the Westpac Rescue Helicopter, the system is set up for reliable 24/7 use and includes a backup engine driven system.



Self-bunded storage tank with on-demand pump system and emergency backup refuelling equipment

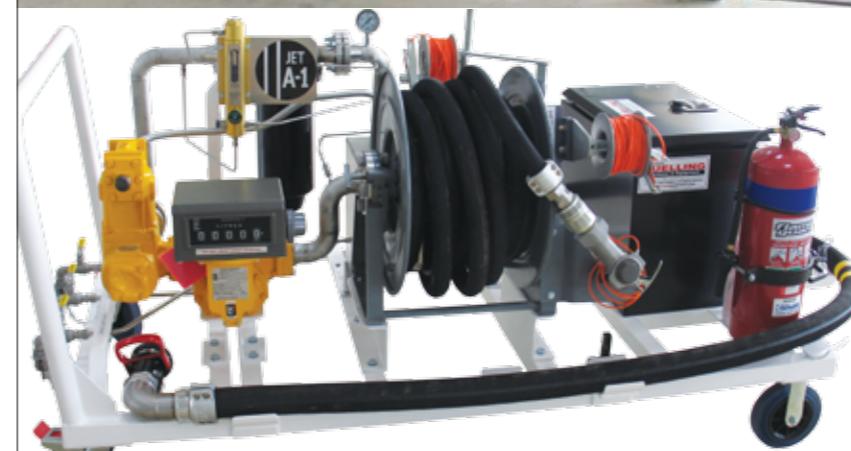

Custom built hydrant cart incorporates filtration with pressure differential gauge, NMI certifiable flowmeter, hose reel & delivery hose with nozzle, hydrant connection hose with drybreak fittings. Also included are spill kit, static reel & fire extinguisher. The unit is easily manually maneuvered to where required.



Shows hydrant cart connected to fuel supply in pit.



Emergency engine-powered backup pump system

Self-bunded tank and dispenser systems

Refuelling Trailers for Class 3 Flammable Liquids

JET-A1 refuelling trailer with 5000 litre tank - with over wing and single point nozzles, comprehensive fuel quality testing equipment, hydraulically operated pumping system and hose reel rewind. Fitted with NMI approved dispensing system for resale of fuel, this trailer is built in compliance with all regulations for high-way use - available with or without DG Approvals. This vehicle available with capacities up to 10,000 litres.

[Click here for video of trailer refuelling an S92 helicopter](#)



Call or email for quotation

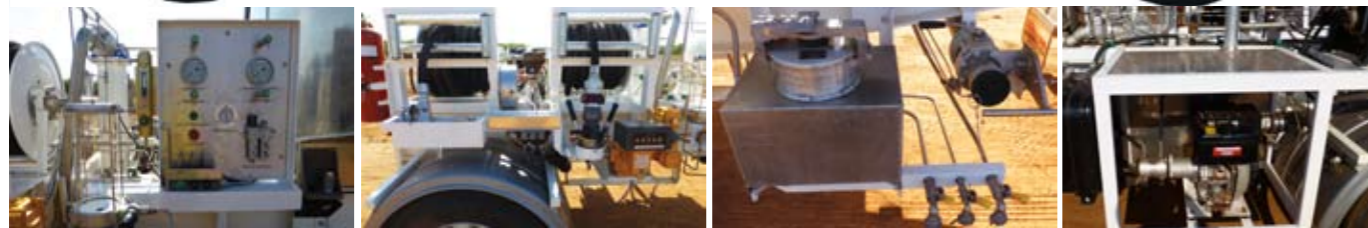

Fuel quality testing station

Dual hydraulic rewind hose reels for over and under wing nozzles

Product recovery tank, drain & sampling valves.

Yanmar diesel-powered hydraulic power pack

Vehicle features & Options

- 4000 to 10,000L capacities
- With or without DG Approvals
- Bottom or top fill tanks
- Over/Under or both nozzles
- NMI approved metering systems
- Comprehensive OH&S & operation manuals
- Fitted with 9kg fire extinguisher in heavy duty bracket
- Spill kit
- Supplied with all statutory signs - to be fitted on-site
- Safe access to tank top for fill/dipping with hand rail & step
- Choice of tow hitch systems
- Operator training & commissioning available



Mobile aviation refuelling systems can be trailer or truck mounted with overwing or single point refuelling (or both) and with or without full DG Approvals for use on public roads.

Australian Fuelling Systems & Equipment

PO Box 7162 NEMSC 2348 7-11 Armstrong Street Tamworth 2340
Ph: +61 2 6760 7816 Fax: +61 2 6760 7826

www.fuelequipment.com

32

**Australian
FUELLING
Systems & Equipment**

IBC & Pump packages - Rent or Buy

Available to buy or to rent, these systems can provide complete refuelling facilities. Available in 1000, 2000 and 3000 litre capacities. Dispensing systems can be manual, DC electric or diesel engine-powered with a wide range of options to suit most applications.



IBC with 12v or 24v DC pump system as shown.

Includes pump/filter portable pump with Kamlok male 25mm connections and 3.5m x 25mm hose assembly with 25mm female kamlok to connect to pump and 50mm female Kamlok to fit to IBC suction pipe. Static wire with clip

You will then need to specify:

- Delivery hose length (see table)
- Nozzle
- Flowmeter



Elaflex ZVF25 Nozzle



Piusi K24EX meter

Delivery Hoses

Cat No	ID	Length	Fittings
062508	25mm	3m	25mm(m) x Kamlok(f)
062509	25mm	6m	25mm(m) x Kamlok(f)
062510	25mm	10m	25mm(m) x Kamlok(f)
062511	25mm	15m	25mm(m) x Kamlok(f)
052512	25mm	20m	25mm(m) x Kamlok(f)

Nozzle

041411			Elaflex ZVF25
--------	--	--	---------------

Flow Meter

053309			Piusi K24EX1
--------	--	--	--------------

Australian Fuelling Systems & Equipment

PO Box 7162 NEMSC 2348 7-11 Armstrong Street Tamworth 2340
Ph: +61 2 6760 7816 Fax: +61 2 6760 7826

www.fuelequipment.com

33

**Australian
FUELLING
Systems & Equipment**

Airport Refuelling Installation

System shown below was designed, built and installed at a SW Queensland airport for refuelling a wide variety of aircraft. Capable of both over wing and single point refuelling with certified metering for resale. 22,000 litre all-stainless, self-bunded storage tank with high-flow inflill pump. Fitted to filter fuel both in and out of tank. Dispenser fitted with digital high visibility register.



View of complete installation showing tank, stainless pipework, electrical and dispenser.



Tank inflill and dispensing pumps. Fitted with filtration, pressure differential gauge, emergency stop

Features

- Pump systems for inflill from tanker and for delivery to dispenser
- All-stainless 22k self-bunded storage
- All-stainless pipework & fittings
- Provides both over wing and single point refuelling with dual flow rates to suit.
- Approved metering for resale
- High visibility digital meter register for easy remote viewing.
- Dewatering/sampling pump operable from ground level

We offer design, build, installation and commissioning as well as periodic auditing & maintenance services for aviation refuelling systems



22,000 Litre all-stainless self-bunded tank



Dispenser with high capacity hose reel, filter, static reel and over and under wing refuelling nozzles.

Australian Fuelling Systems & Equipment

PO Box 7162 NEMSC 2348 7-11 Armstrong Street Tamworth 2340
Ph: +61 2 6760 7816 Fax: +61 2 6760 7826

www.fuelequipment.com

34

**Australian
FUELLING
Systems & Equipment**

Self-Bunded Aviation Fuel Storage Tanks

Australian Fuelling Systems & Equipment manufactures a wide range of aviation fuel storage tanks. These include self-bunded and conventional single skin tanks. We also specialise in the design and fitting of all required dispensing, filtration, metering and management equipment. All systems are thoroughly wet tested prior to despatch to minimise onsite works and commissioning.



Australian designed & manufactured

With 304 Stainless Steel inner and outer tanks, ladder, platform & fixtures

Now with All-Stainless Construction

Our range of self-bunded aviation fuel tanks now feature construction entirely of Grade 304 Stainless Steel - includes the ladder & access platform. Piping & valves are in 316 Stainless with some items of aluminium - thus virtually making these tanks maintenance free.

The range includes tanks from nominal 5,000 litres to 50,000 litres (see table)

Built in compliance with AS1940, AS1692 and AS1657 as well as the special features required for safe storage and handling of aviation fuels.

Features

- Capacities from 5,000 to 50,000 Litres
- Constructed of Grade 304 stainless steel
- 30:1 sloped tank floor
- Collection sump with manual diaphragm dewater/sampling pump - operable from ground level.
- 600mm man access hatch
- 9kg fire extinguisher & bracket
- All statutory signage
- Built to include floating suction option if required.
- Calibrated dipstick
- All welds passivated
- 270mm inspection hatch
- Riser pipes for vents to 4m from ground
- Optional pumping equipment cabinet available
- Wide range of dispenser sets available
- Optional attached or remote equipment cabinets

Australian Fuelling Systems & Equipment

PO Box 7162 NEMSC 2348 7-11 Armstrong Street Tamworth 2340
Ph: +61 2 6760 7816 Fax: +61 2 6760 7826

www.fuelequipment.com

35

**Australian
FUELLING
Systems & Equipment**