



COMPLETO
COMPLETO EVA3
MOBILIO

Werkstatteinrichtung
Équipement pour l'atelier
Attrezzature da officina



smarttablet



KRAFTWERK FLIPPING BOOKS



Auf Ihrem **KRAFTWERK** Smart Tablet können Sie neu die **KRAFTWERK** Kataloge auch **offline** ansehen.

Installieren Sie dazu die App FlippingBook-Reader (Google Konto erforderlich) und folgen Sie danach der Anleitung.

*Grâce à votre tablette **KRAFTWERK**, vous pouvez consulter votre catalogue **KRAFTWERK** à tout moment, même **hors connexion** Internet.*

Pour cela, installez simplement l'application Flipping Book Reader (compte Google requis) et suivez les instructions.

Con il vostro Smart Tablet **KRAFTWERK** potrete consultare i cataloghi **KRAFTWERK** in ogni momento.

È sufficiente installare l'App FlippingBookReader (account Google necessario) e seguire le istruzioni riportate di seguito.



WORLD of
quality **TOOLS**

KRAFTWERK[®]
quality tools



Unsere weiteren Produkte befinden
sich in den Spezial-Katalogen:

*Les autres produits sont consultables
sur nos catalogues thématiques :*

Altri prodotti KRAFTWERK
nei cataloghi speciali:

General Collection

LIGHT Collection

WORK+FASHION Collection

HIGHTECH



1
ABS-Arbeitsabdeckung mit Ablagefächern
beständig gegen Chemikalien.

*Plateau de travail ABS avec casiers,
résistant aux produits chimiques.*

Ripiano di lavoro in ABS con vani portaoggetti,
resistente ai prodotti chimici.

2
Einfingerbedienbare und federleichtgängige,
kugelgelagerte **Vollauszug-Schubladen**,
herausnehmbar.

*Ouverture totale facilitée du tiroirs - mécanisme
à roulement - tiroir extractible.*

Cassetti estraibili, montati su guide con
cuscinetti a sfera per un preciso e morbido
scorrimento e con **apertura totale**.

3
Einhand-Einzelschubladenverriegelung unter
der Griffblende; auch während der Fahrt bleiben
die Schubladen sicher arretiert.

*Verrouillage de chaque tiroir sous la poignée
d'ouverture; même durant le déplacement de la
servante les tiroirs restent fermés.*

Con leva di bloccaggio sui singoli cassetti;
anche durante uno spostamento i cassetti
rimangono chiusi.

4
Vielfältiges Zubehör
zum direkten Anbau an die stabile Doppelwand-
konstruktion der Werkstattwagen.

*Large gamme d'accessoires
pour un montage direct sur la structure
très robuste à double paroi de la servante d'atelier.*

Vasta gamma di accessori
da fissare a lato del robusto telaio,
realizzato in doppia lamiera.

5
Auszugsgriffeleiste mit Führung für **individuelle
Inhaltsbeschriftung**.

*Porte étiquette plexi amovible en façade du
tiroir pour indication individuelle du contenu.*

Porta etichette sul frontale del cassetto per una
immediata individuazione del contenuto.



7
Kugelgelagerte Hochleistungsräder
für optimales Manövrieren. Lenkrollen
mit Rollenbremse.

*Roues sur roulement à billes haute
performance pour maniabilité optimale.
2 roues pivotantes avec freins.*

Ruote girevoli dotate di sistema frenante
e con **cuscinetti a sfera** per un'ottimale
facilità di manovra.



6
Offene Schubladen können auch bei
geschlossenem Wagen in den Wagen-
körper zurückgeschoben werden.

*Système de fermeture centralisée :
même lorsque la servante est verrouillée
les tiroirs ouverts peuvent être refermés.*

Sistema di chiusura centralizzata: i cassetti
ancora aperti si possono chiudere anche
dopo quando il carrello è già stato chiuso.

Werkstattwagen
 Servante d'atelier
 Carrello porta utensili

Art.	
3907-1	6

	L1 / mm	L2 / mm	L3 / mm	kg
	650	485	943	215
A	533	414	70	25
B	533	414	110	30
C	533	414	230	30



Werkstattwagen
 Servante d'atelier
 Carrello porta utensili

Art.	
3908	8

	L1 / mm	L2 / mm	L3 / mm	kg
	650	485	943	265
A	533	414	60	25
B	533	414	110	30



Werkstattwagen
Servante d'atelier
Carrello porta utensili

Art.	
3909	11

	L1 / mm	L2 / mm	L3 / mm	kg
	650	485	970	290
A	533	414	70	20
B	533	414	65	25
C	533	414	110	30



Werkzeugkoffer zu Werkstattwagen
Coffre pour servantes
Cassettera portatile per carrelli

Art.	
3905	4

	L1 / mm	L2 / mm	L3 / mm	kg
	650	485	430	130
A	533	414	70	20
B	533	414	65	25
C	533	414	110	30



Passend zu
S'adapte sur
Compatibile con



LARGO HIGHTECH



Werkstattwagen, extra lang
 Servante d'atelier, extra longue
 Carrello porta utensili, extra largo

Art.	
3910	8

	L1 / mm	L2 / mm	L3 / mm	⚖️ kg
	1015	485	970	480
A	883	414	55	50
B	883	414	105	60



EXTRA LARGO

Rollende Werkbank / extra langer Werkstattwagen

- mit 12 kugelgelagerten, einzeln verriegelbaren Vollauszug-Schubladen, 9 davon ideal passend für 27 COMPLETEO-Werkzeug-Einlagen
- Fach mit Türe und 2 Verstellböden
- Zentralverriegelung
- 25 mm dicke Multiplex-Platte, made in Germany
- 4 PP-Industrie-Räder, 2 fix und 2 lenkbar, je mit Rollenbremse
- Tragkraft: 30-35 kg pro Schublade
- Statische Tragkraft: 450-500 kg.

EXTRA LARGO

Etabli roulant / servante d'atelier extra-longue

- Avec 12 tiroirs à ouverture totale, sur glissières à roulements à billes et verrouillage individuel de chaque tiroir, dont 9 sont idéalement adaptés pour intégrer 27 coquilles COMPLETEO
- Compartiment avec porte et 2 étagères réglables
- Verrouillage centralisé
- Plateau multiplex de 25 mm d'épaisseur, made in Germany
- 4 roues PP industrielles avec frein, 2 fixes et 2 orientables
- Capacité: 30-35 kg par tiroir
- Capacité de charge statique: 450-500 kg.

EXTRA LARGO

Banco da lavoro rotabile / carrello per officina extra lungo

- con 12 cassetti montati su guide con cuscinetti a sfera e con apertura totale, 9 cassetti idealmente adatti per 27 vaschette COMPLETEO
- Compartimento con sportello e 2 scaffali regolabili
- Sistema di chiusura centralizzata
- Tavola multistrato da 25 mm di spessore, made in Germany
- 4 ruote in PP industriale, 2 fisse e 2 orientabili, tutte con freno
- Capacità: 30-35 kg per cassetto
- Capacità portata statica: 450-500 kg.



Art. **3936**

COMPLETEO compatible

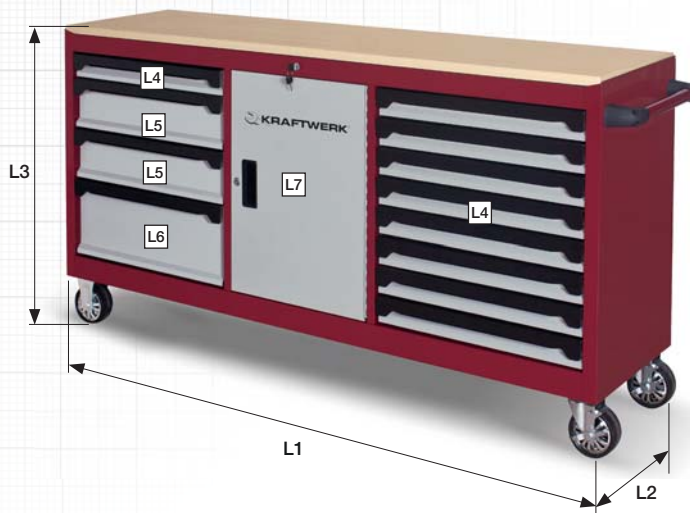

	L1 / mm	L2 / mm	L3 / mm
	1800	459	940
L4	568	413	66
L5	568	413	145
L6	568	413	224
L7	459	454	638

Kleinteile-Schalensatz zu 4920

Jeu de coquilles pour petites pièces pour 4920

Set di vaschette portaminuteria per 4920

9
PCS



Art. **3936ES**



405 x 45 x 42 mm

Service-Werkstattwagen

mit grossem Werkzeugfach, Deckel sanft hebend und schliessend dank Gasdruckfedern, 3 kugelgelagerte Schubladen, grosses Bodenfach.

Servante spéciale d'atelier

avec grand compartiment, 3 tiroirs à roulement à ouverture et fermeture douces grâce au ralentisseur à gaz, grand compartiment inférieur.

Carrello di servizio

con grande compartimento, lieve apertura e chiusura grazie a sospensioni a gas, 3 cassetti su cuscinetti, grande compartimento inferiore.

Art.	
3917	3

	L1 / mm	L2 / mm	L3 / mm	kg
	792	445	960	160
A	690	410	104	40
B	650	355	45	20
C	650	355	68	30
D	650	355	100	30
E	768	410		40



Werkstattwagen TRIO

ohne Werkzeuge

Servante TRIO

sans outils

Carrello TRIO

senza utensili

Art.	
3934	



688 × 482 × 1012 mm

MDF-Deckplatte

zu Werkstattwagen TRIO

Plateau MDF

pour servante TRIO

Pannello in MDF

per carrello TRIO

Art.	
3934-99	

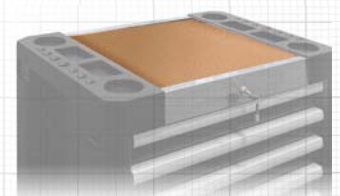

432 × 428 × 16 mm

Werkstattwagen CINCO

ohne Werkzeuge

Servante CINCO

sans outils

Carrello CINCO

senza utensili

Art.

3935

MDF-Deckplatte

zu Werkstattwagen CINCO

Plateau MDF

pour servante CINCO

Pannello in MDF

per carrello CINCO

Art.

3935-99

Werkzeugwagen

mit kugelgelagerten und einzeln verriegelbaren Vollauszug-Schubladen mit Zentralverschluss.

Servante

avec tiroirs à roulement, ouverture totale, verrouillage de chaque tiroir, fermeture centralisée.

Carrello porta utensili

con cassette completamente estraibili dotati di guide su cuscinetti a sfera, blocco del singolo cassetto e chiusura centralizzata con serratura.

Art.



2905

5

	L1 / mm	L2 / mm	L3 / mm	⚖️ kg
	695	475	885	200
A	536	410	60	25
B	536	410	124	30
C	536	410	172	30



Special Edition



↕ 1044.5 × 482 × 1012 mm



↕ 788 × 428 × 16 mm

KRAFTWERK RACING

COMPLETO Compatible



Werkzeugwagen

mit kuggelagerten und einzeln verriegelbaren Vollauszug-Schubladen mit Zentralverschluss.

Servante

avec tiroirs à roulement, ouverture totale, verrouillage de chaque tiroir, fermeture centralisée.

Carrello porta utensili

con cassetti completamente estraibili dotati di guide su cuscinetti a sfera, blocco del singolo cassetto e chiusura centralizzata con serratura.

COMPLETO Compatible

Art.	
2907	7

	L1 / mm	L2 / mm	L3 / mm	kg
	695	475	885	240
A	536	410	45	25
B	536	410	60	30
C	536	410	172	30



Werkzeugkoffer zu Werkzeugwagen

mit kuggelagerten und einzeln verriegelbaren Vollauszug-Schubladen mit Zentralverschluss.

Coffre pour servantes

avec tiroirs à roulement, ouverture totale, verrouillage de chaque tiroir, fermeture centralisée.

Cassettiera portatile per carrelli

con cassetti completamente estraibili dotati di guide su cuscinetti a sfera, blocco del singolo cassetto e chiusura centralizzata con serratura.

COMPLETO Compatible

Art.	
2904	3

	L1 / mm	L2 / mm	L3 / mm	kg
	695	475	345	115
A	536	410	60	25



Passend zu
S'adapte sur
Compatible con



2905



2907

Werkzeugwagen
Servante
Carrello porta utensili

Art.	
1906	6

	L1 / mm	L2 / mm	L3 / mm	kg
	678	405	925	150
A	570	370	56	20
B	570	370	81	20
C	570	370	106	20
D	570	370	155	20



Werkzeugwagen
Servante
Carrello porta utensili

Art.	
1907	7

	L1 / mm	L2 / mm	L3 / mm	kg
	682	458	1000	205
A	565	395	58	25
B	565	395	138	30



Schubladen-Gummi-Antirutschmatte
Tapis caoutchouc anti-dérapant pour tiroirs
Tappetino in gomma antiscivolo per cassetti

Art.	
3918	3907-1 / 3908 / 3909

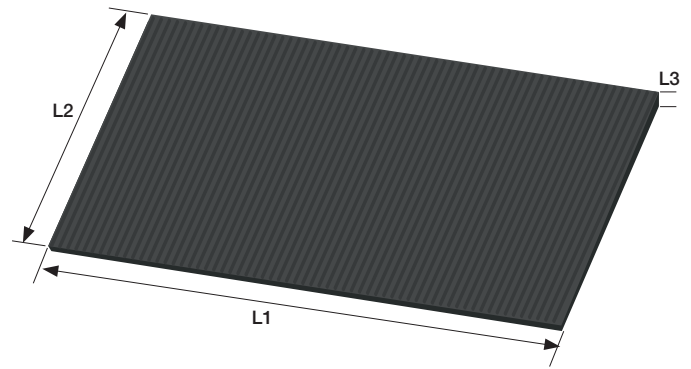

↕ L1 530 × L2 405 × L3 2 mm

Schubladen-Unterteiler-Einsatz
aus verzinktem Stahlblech
Insert de séparation „U“ pour tiroirs
en acier zingué
Separatore ad „U“ per cassetti
in lamiera d'acciaio zincata

Art.	
3919	3907-1 / 3908 / 3909 / 3910

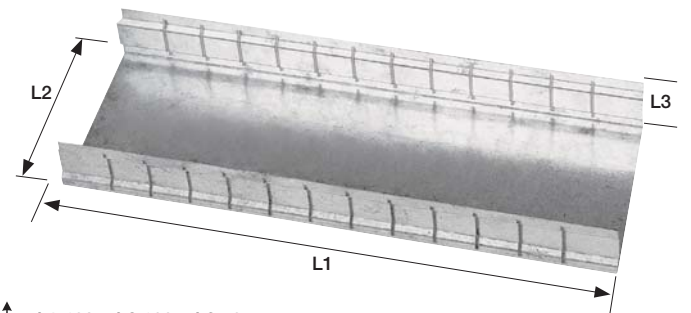

↕ L1 409 × L2 132 × L3 50 mm

Fach-Unterteiler
zu 3919, aus verzinktem Stahlblech
Séparation
pour 3919, en acier zingué
Separatori per cassetti
per 3919, in lamiera d'acciaio zincata

Art.	
3920	3907-1 / 3908 / 3909 / 3910

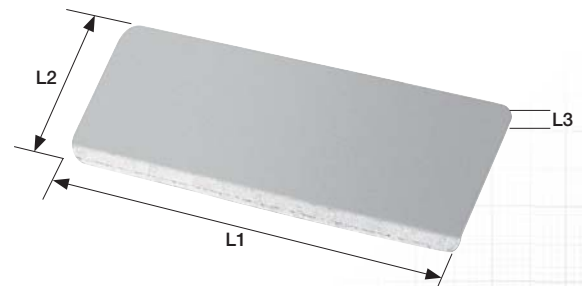
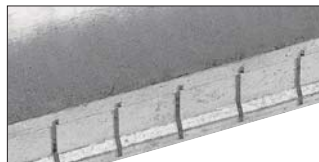

↕ L1 129 × L2 50 × L3 1.2 mm

Schubladeneinlage, flach
Compartment de tiroirs plat
Vaschetta piana per cassetti

Art.

3921

3907-1 / 3908 / 3909

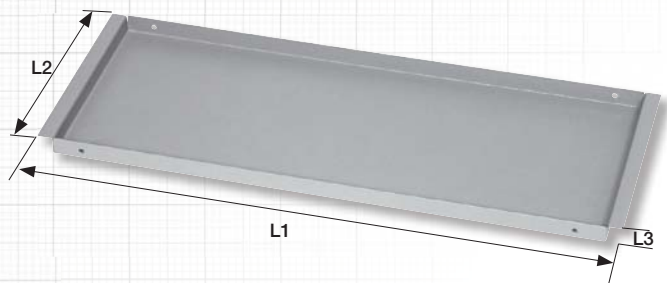

↕ L1 530 × L2 200 × L3 20 mm

Schubladeneinlage, tief
Compartment de tiroirs creux
Vaschetta profonda per cassetti

Art.

3922

3907-1 / 3908 / 3909

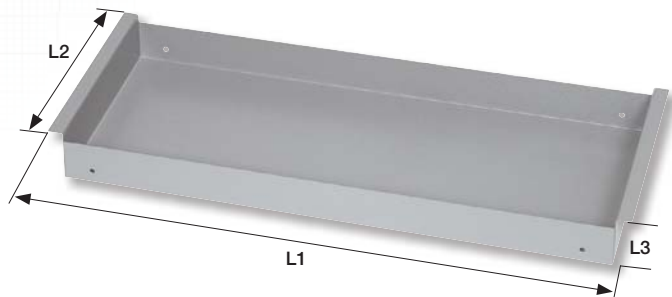

↕ L1 530 × L2 200 × L3 45 mm

Unterteilerschale
Bac de subdivision
Divisori per cassetti

Art.

7721

3907-1 / 3908 / 3909 / 3910 / 2905 /
2907 / 1907



6
PCS



↕ L1 165 × L2 195 × L3 35 mm

Unterteilerschale
Bac de subdivision
Divisori per cassette

Art.
7722 3907-1 / 3908 / 3909 / 3910 / 2905 / 2907 / 1907



6
PCS

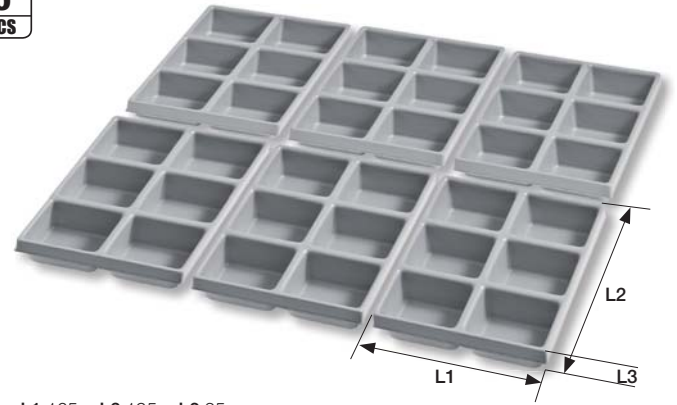

↕ L1 165 × L2 195 × L3 35 mm

Unterteilerschale
Bac de subdivision
Divisori per cassette

Art.
7723 3907-1 / 3908 / 3909 / 3910 / 2905 / 2907 / 1907



6
PCS

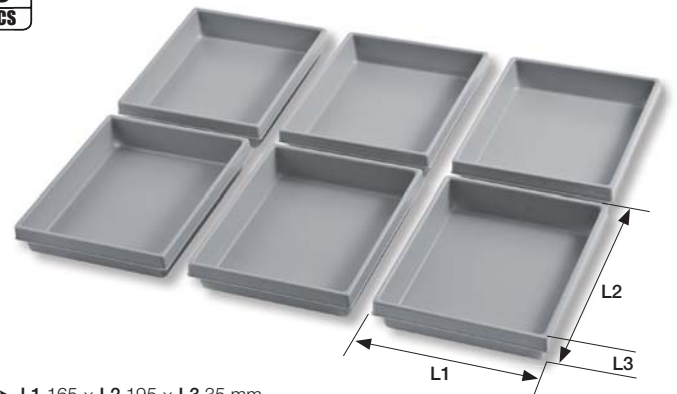

↕ L1 165 × L2 195 × L3 35 mm

Unterteilerschale
Bac de subdivision
Divisori per cassette

Art.
7724 3907-1 / 3908 / 3909 / 3910 / 2905 / 2907 / 1907



3
PCS



↕ L1 160 × L2 390 × L3 35 mm

Unterteilerschalen-Satz
Jeu de bacs de subdivision
Set di divisori per cassetti

5
PCS



Art.	3907-1 / 3908 / 3909 / 3910 / 2905 / 2907 / 1907
7725	



Aussenkorb
mit Einlegewanne
Corbeille extérieure
avec bac
Cestino esterno
con salvagoccia

Art.	3907-1 / 3908 / 3909 / 3910
3923	

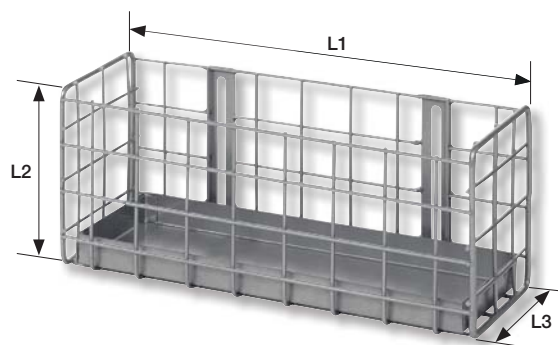

↕ L1 280 × L2 115 × L3 95 mm

Universalkorb
mit Halter
Dévidoir
avec support
Cestino universale
dotato di ganci

Art.	3907-1 / 3908 / 3909 / 3910
3924	

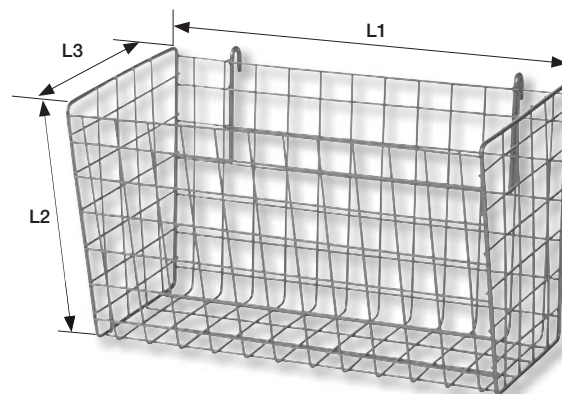
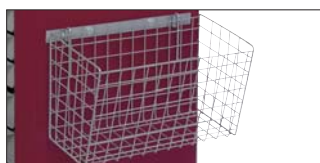

↕ L1 365 × L2 220 × L3 215 mm

Halterung für Reinigungstuch-Rollen Support de rouleau d'essuyage Supporto portarotolo

Art.	
3925	3907-1 / 3908 / 3909 / 3910

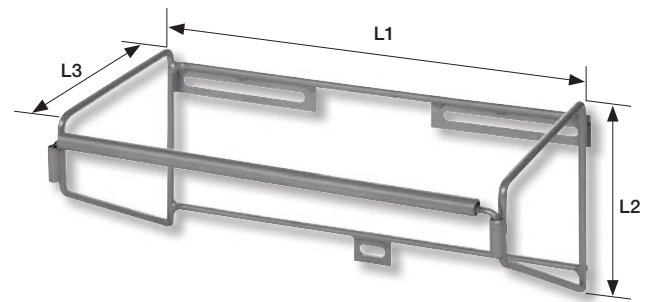

↕ L1 330 × L2 175 × L3 140 mm

Seitentisch

mit integriertem Rollenhalter für den Gebrauch eines Notebooks oder als zusätzliche Abstellfläche.

Table latérale

avec porte-rouleau intégré facilitant l'usage d'un ordinateur ou permettant tout simplement de bénéficier d'un espace de travail supplémentaire.

Tavolino laterale

con portarotolo integrato per l'utilizzo di notebook o semplicemente come spazio di lavoro aggiuntivo.

Art.	
3927	3907-1 / 3908 / 3909 / 3910



↕ L1 385 × L2 380 × L3 375 mm

Seitentisch zu KWR-Werkstattwagen

zum Gebrauch eines Notebooks oder für Dokumentenablage.

Table latérale pour servante KWR

permettant l'usage d'un ordinateur ou le dépôt de documents.

Tavolino laterale per carrelli KWR

per l'utilizzo di notebook o semplicemente come spazio di lavoro aggiuntivo.

Art.	
1927	2905 / 2907



↕ L1 280 × L2 210 mm

Magnetteller

rostfrei

Coupelle magnétique

en inox

Vassoio magnetico

in inox

Art.	
2950	1200 g



↕ Ø 150 × 40 × 40 mm

Magnetteller

rostfrei

Coupelle magnétique

en inox

Vassoio magnetico

in inox

Art.	
2951	2 × 1200 g



↕ 240 × 140 × 40 mm

Magnetischer Werkzeughalter

für Stecknüsse und Druckluftwerkzeuge

Support magnétique

pour douilles et outils pneumatiques

Supporto magnetico

per bussole ed utensili pneumatici

Art.

3929



↕ L 400 mm

Werkstattwagen-Schutzdecke

Housse de protection pour servantes

Telo protezione per carrello

Art.

3930

3907-1 / 3908 / 3909 / 2905 / 2907 /
1906 / 1907



↕ 73 x 55 x 89 mm

Hochwertige Qualität Modulares Werkstatt-Schrank-System

Haute qualité

Systeme de rangement modulaire d'atelier

Alta qualità

Arredamento modulare per l'officina

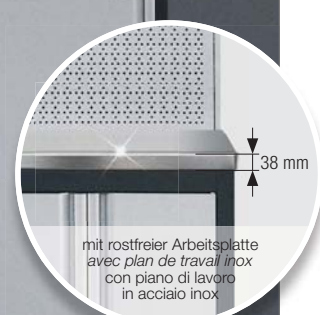
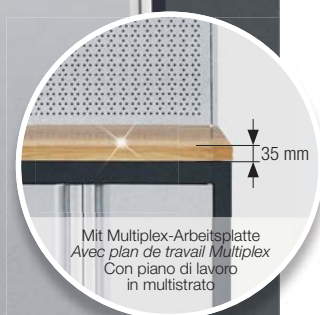

WORLD of
quality TOOLS

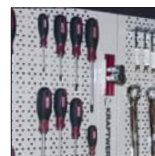
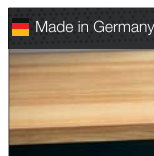

Modulares Element- Werkstatt-Schrank- wand-System

zum Zusammenstellen nach eigenem Bedarf. Freistehende Konstruktion, keine Befestigungen notwendig und daher sehr flexibel aufstellbar. Jedes Modul einzeln bestellbar. Kugelgelagerte Schubladen in verschiedenen Höhen, passend für alle KRAFTWERK Werkzeugeinlagen (COMPLETO Hartschalen, EVA, EVA3) mit Zentralverriegelung und einzeln verriegelbar. Werkzeug-Lochwände mit Euro-Norm-Lochung.

Systeme de rangement modulaire d'atelier

pour un assemblage personnalisable en fonction des besoins. Construction autoportante ne nécessitant ni support mural ni fixations, très facile à installer. Chaque module peut être commandé individuellement. Tiroirs sur roulements à billes avec différentes hauteurs, adaptés à tous les inserts d'outils KRAFTWERK (COMPLETO ABS, EVA, EVA3) avec verrouillage centralisé et individuel. Parois porte-outils perforées Euro standard.

Arredamento modulare per l'officina

per comporre lo spazio secondole proprie esigenze. Costruzione autoportante, non necessita di attacchi nè di muri di sostegno per una installazione facile e flessibile. Ogni modulo può essere ordinato individualmente. Cassetti su cuscinetti a sfera, disponibili in varie altezze, compatibili con i moduli portautensili KRAFTWERK (COMPLETO ABS, EVA, EVA3) con chiusura centralizzata e individuale. Parete portautensili forata Euro-Standard.



3-Element- Werkstatt-Schrankwand

- 2 Oberschränke mit Gasfederung
- 1 Hochschrank mit 4 Tablaren
- 1 Schrankmöbel, 2-türig mit 1 Tablar
- 1 Schubladenschrank mit 5 Schubladen
- 2 Werkzeug-Lochwände
- 1 Arbeitsplatte

Meuble 3 éléments

- 2 meubles hauts avec vérins
- 1 armoire avec 4 tablettes
- 1 meuble bas, 2 portes avec 1 tablette
- 1 meuble bas, 5 tiroirs
- 2 panneaux perforés
- 1 plan de travail

Parete da officina da 3 elementi

- 2 armadi a parete con sportello
ammortizzato a gas
- 1 armadio alto con 4 ripiani
- 1 armadio a due ante con 1 ripiano
- 1 armadio a 5 cassetti
- 2 pareti forate
- 1 piano di lavoro

Art.

3964A

Mit Multiplex-Arbeitsplatte
Avec plan de travail Multiplex
Con piano di lavoro in multistrato
1361 x 463 x 35 mm

3964AIX

Mit rostfreier Arbeitsplatte
Avec plan de travail inox
Con piano di lavoro acciaio inox
1361 x 463 x 38 mm



4-Element- Werkstatt-Schrankwand

- 3 Oberschränke mit Gasfederung
- 1 Hochschrank mit 4 Tablaren
- 1 Schrankmöbel, 2-türig mit 1 Tablar
- 1 Schubladenschrank mit 4 Schubladen
- 1 Schubladenschrank mit 5 Schubladen
- 3 Werkzeug-Lochwände
- 1 Arbeitsplatte

Meuble 4 éléments

- 3 meubles hauts avec vérins
- 1 armoire avec 4 tablettes
- 1 meuble bas, 2 portes avec 1 tablette
- 1 meuble bas, 4 tiroirs
- 1 meuble bas, 5 tiroirs
- 3 panneaux perforés
- 1 plans de travail

Parete da officina da 4 elementi

- 3 armadi a parete con sportello
ammortizzato a gas
- 1 armadio alto con 4 ripiani
- 1 armadio a due ante con 1 ripiano
- 1 armadio a 4 cassetti
- 1 armadio a 5 cassetti
- 3 pareti forate
- 1 piano di lavoro

Art.

3964B

Mit Multiplex-Arbeitsplatte
Avec plan de travail Multiplex
Con piano di lavoro in multistrato
2041 x 463 x 35 mm

3964BIX

Mit rostfreier Arbeitsplatte
Avec plan de travail inox
Con piano di lavoro acciaio inox
2041.5 x 463 x 38 mm

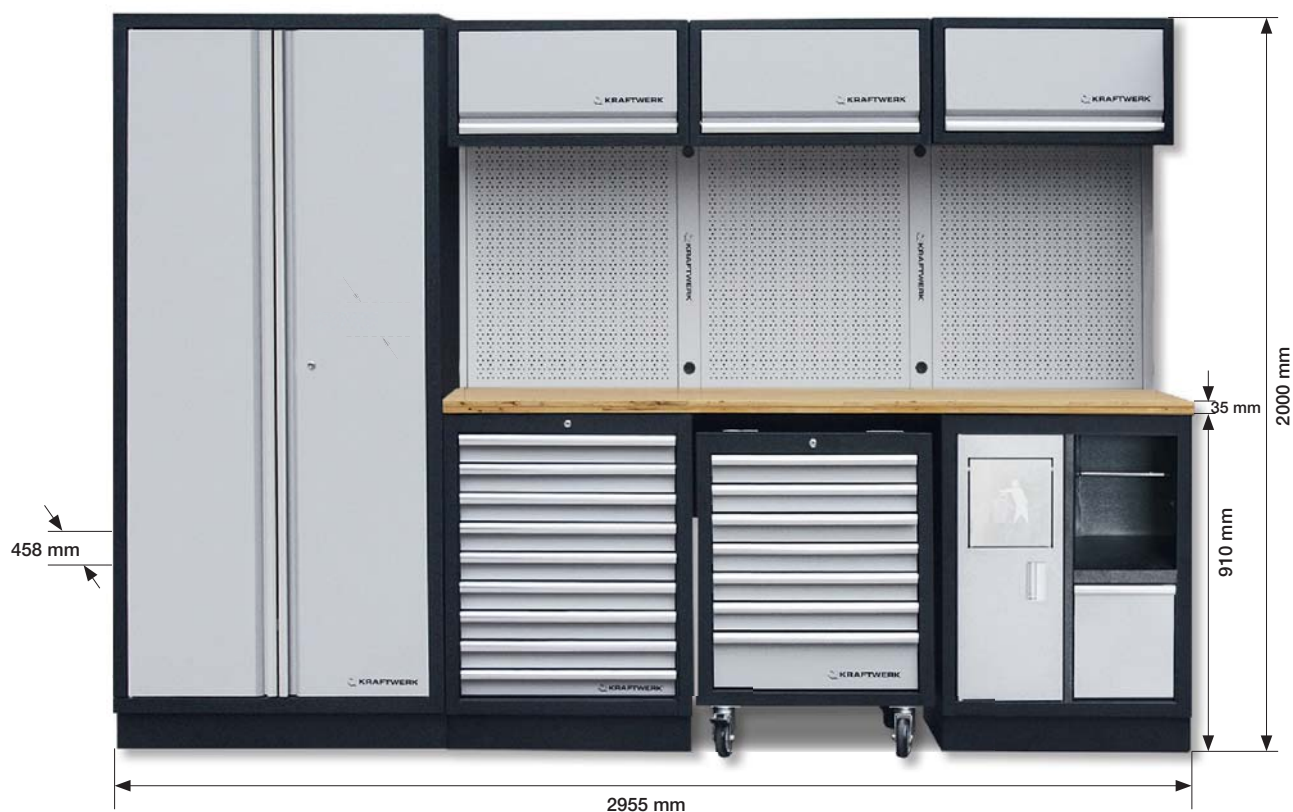

4-Element- Werkstatt-Schrankwand

- 3 Oberschränke mit Gasfederung
- 1 Hochschrank, 2-türig mit 4 Tablaren
- 1 Schubladenschrank mit 9 Schubladen
- 1 Roll-Schubladenschrank mit 7 Schubladen
- 1 Unterschrank mit Abfalleimer/
Papierhalter
- 3 Werkzeug-Lochwände
- 1 Arbeitsplatte

Meuble 4 éléments

- 3 meubles hauts avec vérins
- 1 armoire 2 portes avec 4 tablettes
- 1 meuble bas, 9 tiroirs
- 1 meuble bas à roulettes, 7 tiroirs
- 1 meuble bas avec poubelle intégrée
et support pour rouleaux essuie-tout
- 3 panneaux perforés
- 1 plan de travail

Parete da officina da 4 elementi

- 3 armadi a parete con sportello
ammortizzato a gas
- 1 armadio alto a due ante con 4 ripiani
- 1 armadio a 9 cassetti
- 1 armadio con ruote a 7 cassetti
- 1 armadio con secchio della spazzatura
e supporto per rotolo carta integrato
- 3 pareti forate
- 1 piano di lavoro

Art.

3964D

Mit Multiplex-Arbeitsplatte
Avec plan de travail Multiplex
Con piano di lavoro in multistrato
2041 x 463 x 35 mm

3964DIX

Mit rostfreier Arbeitsplatte
Avec plan de travail inox
Con piano di lavoro acciaio inox
2041.5 x 463 x 38 mm



8-Element- Werkstatt-Schrankwand

- 5 Oberschränke mit Rolläden
- 1 Eck-Oberschrank mit Gasfederung
- 1 Hochschrank mit 4 Tablaren
- 1 Hochschrank, 2-türig mit 4 Tablaren
- 1 Schrankmöbel, 2-türig mit 1 Tablar
- 1 Eck-Schrankmöbel mit 1 Türe
- 1 Schubladenschrank mit 8 Schubladen
- 1 Schubladenschrank mit 4 Schubladen
- 1 Roll-Schubladenschrank mit 7 Schubladen
- 1 Unterschrank mit Abfalleimer/
Papierhalter
- 4 Werkzeug-Lochwände
- 2 Werkzeug-Lochwände zu 3964-16
- 3 Arbeitsplatten

Meuble 8 éléments

- 5 meubles hauts avec véryns
- 1 meuble haut d'angle avec véryns
- 1 armoire avec 4 tablettes
- 1 armoire 2 portes avec 4 tablettes
- 1 meuble bas, 2 portes avec 1 tablette
- 1 meuble d'angle bas à 1 porte
- 1 meuble bas, 8 tiroirs
- 1 meuble bas, 4 tiroirs
- 1 meuble bas à roulettes, 7 tiroirs
- 1 meuble bas avec poubelle intégrée
et support pour rouleaux essuie-tout
- 4 panneaux perforés
- 2 panneaux perforés pour 3964-16
- 3 plans de travail

Parete da officina da 8 elementi

- 5 armadi a parete con sportello a serranda
- 1 armadio a parete ad angolo con sportello ammortizzato a gas
- 1 armadio alto con 4 ripiani
- 1 armadio alto a due ante con 4 ripiani
- 1 armadio a due ante con 1 ripiano
- 1 armadio ad angolo
- 1 armadio a 8 cassetti
- 1 armadio a 4 cassetti
- 1 armadio con ruote a 7 cassetti
- 1 armadio con secchio della spazzatura e supporto per rotolo carta integrato
- 4 pareti forate
- 2 pareti forate per 3964-16
- 3 piani di lavoro

Art.

3964E

Mit Multiplex-Arbeitsplatte
Avec plan de travail Multiplex
Con piano di lavoro in multistrato
864 x 864 x 35 mm
1361 x 463 x 35 mm
2041 x 463 x 35 mm

3964EIX

Mit rostfreier Arbeitsplatte
Avec plan de travail inox
Con piano di lavoro acciaio inox
865 x 865 x 38 mm
1361 x 463 x 38 mm
2041.5 x 463 x 38 mm



6-Element- Werkstatt-Schrankwand

- 4 Oberschränke mit Gasfederung
- 2 Hochschränke mit 4 Tablar
- 1 Schrankmöbel, 2-türig mit 1 Tablar
- 1 Schubladenschrank mit 4 Schubladen
- 1 Schubladenschrank mit 5 Schubladen
- 1 Schubladenschrank mit 9 Schubladen
- 4 Werkzeug-Lochwände
- 2 Arbeitsplatten

Meuble 6 éléments

- 4 meubles hauts avec vérins
- 2 armoires avec 4 tablettes
- 1 meuble bas, 2 portes avec 1 tablette
- 1 meuble bas, 4 tiroirs
- 1 meuble bas, 5 tiroirs
- 1 meuble bas, 9 tiroirs
- 4 panneaux perforés
- 2 plans de travail

Parete da officina da 6 elementi

- 4 armadi a parete con sportello ammortizzato a gas
- 2 armadi alti con 4 ripiani
- 1 armadio a due ante con 1 ripiano
- 1 armadio a 4 cassetti
- 1 armadio a 5 cassetti
- 1 armadio a 9 cassetti
- 4 pareti forate
- 2 piani di lavoro

Art.

3964F

Mit Multiplex-Arbeitsplatte
Avec plan de travail Multiplex
Con piano di lavoro in multistrato
2x 1361 x 463 x 35 mm

3964FIX

Mit rostfreier Arbeitsplatte
Avec plan de travail inox
Con piano di lavoro acciaio inox
2x 1361 x 463 x 38 mm

Hochschrank

mit 4 Tablaren

Armoire

avec 4 tablettes

Armadio alto

con 4 ripiani

Art.

3964-02

↕ 600 × 458 × 2000 mm



Tablar

zu 3964-02

Tablette

pour 3964-02

Ripiano

per 3964-02

Art.

3964-02-07

↕ 590 × 430 × 20 mm



Flügeltürschrank

mit 4 Tablaren

Armoire

à portes battantes avec 4 tablettes

Armadio alto

a due ante con 4 ripiani

Art.

3964-12

↕ 915 × 458 × 2000 mm



Tablar

zu 3964-12

Tablette

pour 3964-12

Ripiano

per 3964-12

Art.

3964-12-01

↕ 905 × 430 × 20 mm



Schrankmöbel

mit 2 Türen und 1 Tablar

Meuble bas

avec 2 portes avec 1 tablette

Armadio

a due ante con 1 ripiano

Art.

3964-03

↕ 600 × 458 × 910 mm



Schubladenschrank

mit 4 Schubladen

Meuble bas

avec 4 tiroirs

Armadio base

con 4 cassetti

Art.

3964-04

↕ 680 × 458 × 910 mm



Schubladenschrank

mit 5 Schubladen

Meuble bas

avec 5 tiroirs

Armadio base

con 5 cassetti

Art.

3964-05

↕ 680 × 458 × 910 mm



Schubladenschrank

mit 8 Schubladen

Meuble bas

avec 8 tiroirs

Armadio base

con 8 cassetti

Art.

3964-14

↕ 680 × 458 × 910 mm



Schubladenschrank

mit 9 Schubladen

Meuble bas

avec 9 tiroirs

Armadio base

con 9 cassetti

Art.

3964-13

680 × 458 × 2000 mm



Roll-Schubladenschrank

mit 7 Schubladen

Meuble bas

à roulettes avec 7 tiroirs

Armadio

con ruote a 7 cassetti

Art.

3964-15

646 × 458 × 862 mm



Unterschrank

mit integriertem Abfalleimer und Halterung für Putzrollen

Meuble bas

avec poubelle intégrée et support pour rouleaux essuie-tout

Armadietto base

con pattumiera e supporto per rotoli di carta

Art.

3964-11

680 × 458 × 910 mm



Eck-Schrankmöbel

mit 1 Türe und 1 Tablar

Meuble d'angle bas

avec 1 porte et 1 tablette

Armadietto angolare

con una porta e una anta

Art.

3964-16

864 × 864 × 910 mm



Oberschrank

mit Gasfederung

Meuble haut

avec vérins

Armadi a parete

con sportello ammortizzato a gas

Art.

3964-01



↕ 680 × 281 × 350 mm

Oberschrank

mit Rollladen

Meuble haut

à rideau

Armadi a parete

con sportello a serranda

Art.

3964-19



↕ 680 × 281 × 350 mm

Eck-Oberschrank

mit Gasfederung

Meuble haut d'angle

avec vérins

Armadio a parete ad angolo

con sportello ammortizzato a gas

Art.

3964-25



↕ 865 × 865 × 350 mm



Werkzeug-Lochwand

zu 3964-16

Panneau perforé mural

pour 3964-16

Pannello forato

per 3964-16

Art.

3964-17

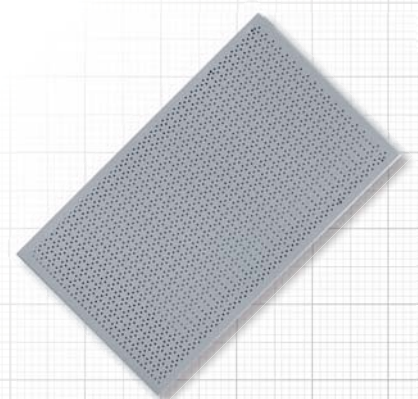

↕ 1052 × 798 × 25 mm

Werkzeug-Lochwand
Panneau perforé
Pannelo forato

Art.

3964-06

↕ 1052 × 614.5 × 25 mm

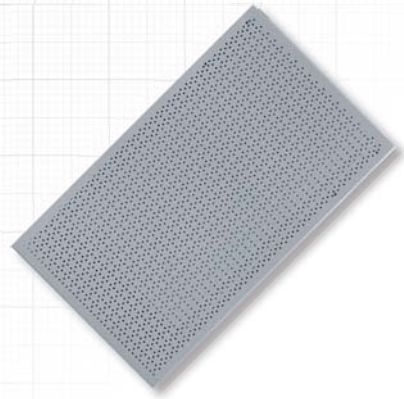

Verbindungsstange
für Verbindungen von zwei Elementen

Barre de raccordement
pour jonction entre 2 éléments

Supporto
per connessione di 2 elementi

Art.

3964-24

↕ 1420 × 65 × 30 mm



Verbindungsstange
für Verbindungen von zwei Elementen mit Kabelöffnung

Barre de raccordement
pour jonction entre 2 éléments avec passage de câbles

Supporto
per connessione di 2 elementi con fori per cavi

Art.

3964-07

↕ 1420 × 65 × 30 mm



Verbindungsstange für Aussenrahmen
Barre de raccordement pour structure externe
Supporto per connessione telaio esterno

Art.

3964-10

↕ 1420 × 32.5 × 30 mm



Multiplex-Arbeitsplatte

für 1 Element

Plan de travail Multiplex

pour 1 élément

Piano di lavoro in multistrato

per 1 elemento

Art.

3964-08

 Made in Germany



 680 × 463 × 35 mm

Multiplex-Arbeitsplatte

für 2 Elemente

Plan de travail Multiplex

pour 2 éléments

Piano di lavoro in multistrato

per 2 elementi

Art.

3964-09

 Made in Germany



 1361 × 463 × 35 mm

Multiplex-Arbeitsplatte

für 3 Elemente

Plan de travail Multiplex

pour 3 éléments

Piano di lavoro in multistrato

per 3 elementi

Art.

3964-18

 Made in Germany



 2041 × 463 × 35 mm

Multiplex-Arbeitsplatte

zu 3964-16

Plan de travail Multiplex

pour 3964-16

Piano di lavoro in multistrato

per 3964-16

Art.

3964-16-99

 Made in Germany



 864 × 864 × 35 mm

Rostfreie Arbeitsplatte

für 1 Element

Plan de travail inox

pour 1 élément

Piano di lavoro in acciaio inossidabile

per 1 elemento

Art.

3964-20

↕ 680 × 463 × 38 mm



Rostfreie Arbeitsplatte

für 2 Elemente

Plan de travail inox

pour 2 éléments

Piano di lavoro in acciaio inossidabile

per 2 elementi

Art.

3964-21

↕ 1361 × 463 × 38 mm



Rostfreie Arbeitsplatte

für 3 Elemente

Plan de travail inox

pour 3 éléments

Piano di lavoro in acciaio inossidabile

per 3 elementi

Art.

3964-22

↕ 2041.5 × 463 × 38 mm



Rostfreie Arbeitsplatte

zu 3964-16

Plan de travail inox

pour 3964-16

Piano di lavoro in acciaio inossidabile

per 3964-16

Art.

3964-23

↕ 865 × 865 × 38 mm



Spitz-Haken
Crochet pointu
 Gancio euroforo

Art.	L
90359	150 mm

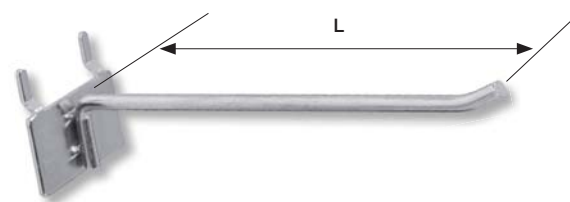

Spitz-Haken
Crochet pointu
 Gancio euroforo

Art.	L
90354	100 mm

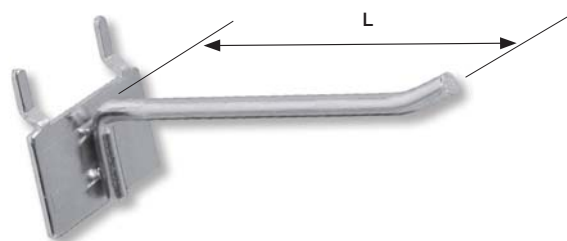

Spitz-Haken
Crochet pointu
 Gancio euroforo

Art.	L
90377	60 mm

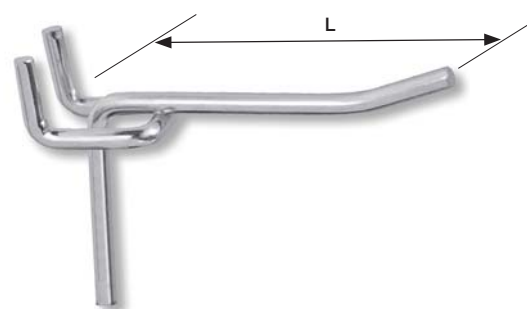

Halterung für Reinigungstuch-Rollen
Support de rouleau d'essuyage
 Supporto portarotolo

Art.
3925

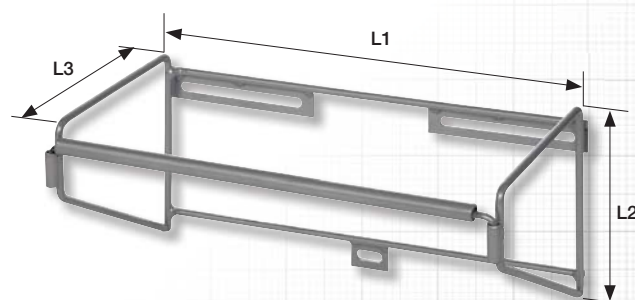

↕ L1 330 × L2 175 × L3 140 mm

Aussenkorb

mit Einlegewanne

Corbeille extérieure

avec bac

Cestino esterno

con salvagoccia

Art.

3923

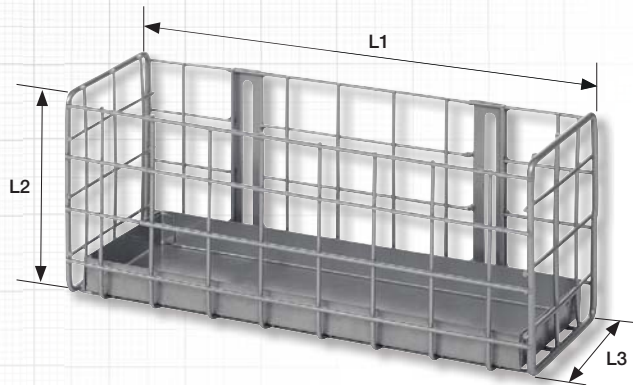
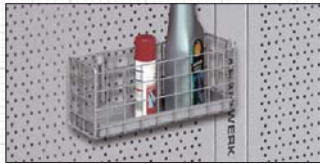

↕ L1 280 x L2 115 x L3 95 mm

Magnetischer Werkzeughalter

für Stecknüsse und Druckluftwerkzeuge

Support magnétique

pour douilles et outils pneumatiques

Supporto magnetico

per bussole ed utensili pneumatici

Art.

L

3929

400 mm



Werkbänke

mit höhenverstellbaren Stellfüßen, 3 cm dicke Multiplexplatte, spritzwasserfest, schmutzabweisend und weitgehend unempfindlich gegen Öl und Fett. Max. Belastbarkeit 150 kg.

Établi

avec réglage du niveau, plateau Multiplex 3 cm, résistant aux projections d'eau, anti-poussières et très résistant aux graisses et à l'huile.

Charge maximale : 150 KG

Banchi da lavoro

con regolatre di livello, piano di lavoro di 3 cm, resistente agli spruzzi d'acqua, resistente allo sporco e ampiamente immune e agli olii e al grasso. Portata massima 150 kg.

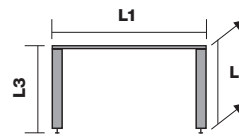

Art.
7526
7527

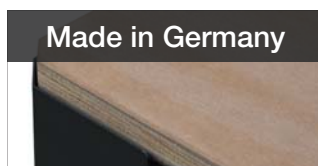

	L1 / mm	L2 / mm	L3 / mm	Δ kg
7526	1600	600	880 - 930	150
7527	1600	800	880 - 930	150

Werkbank

in robuster Stahlblechkonstruktion, mit 20 mm starker Buchen-Multiplex-Arbeitsplatte mit zusätzlichem Schutz durch Leinölfirnis. 3 kugelgelagerte Schubladen. KRAFTWERK-Werkzeugeinlagen (COMPLETEO-Hartschalen, EVA, EVA3) haben bequem in der unteren, langen Schublade Platz. Eine Werkzeugwand und ein Oberschrank bieten viel Stauraum für Werkzeuge.

Établi

avec une structure robuste en acier, un plan de travail multiplex de 20 mm d'épaisseur en hêtre protégé par un vernis d'huile de lin. 3 tiroirs sur roulements à billes. Les inserts d'outils KRAFTWERK (COMPLETEO-rigide, EVA, EVA3) trouvent leur place dans le tiroir inférieur. La paroi perforée et les meubles à abattant haut offrent un bel espace de rangement pour les outils.

Banco la lavoro

con solida struttura in acciaio, piano di lavoro in multistrato da 20mm in faggio con protezione grazie alla verniciatura all'olio di lino. 3 Cassetti su cuscinetti a sfera. I moduli portautensili KRAFTWERK (COMPLETEO, EVA, EVA3) trovano posto nel cassetto inferiore. Completo di parete forata ed armadietto a parete.



	L1 / mm	L2 / mm	L3 / mm	Δ kg
	1145	635	1585	80
L4	457	423	93	20
L5	921	483	93	30

Art.
3962

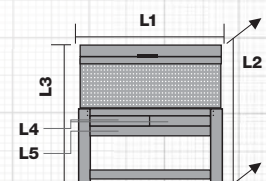

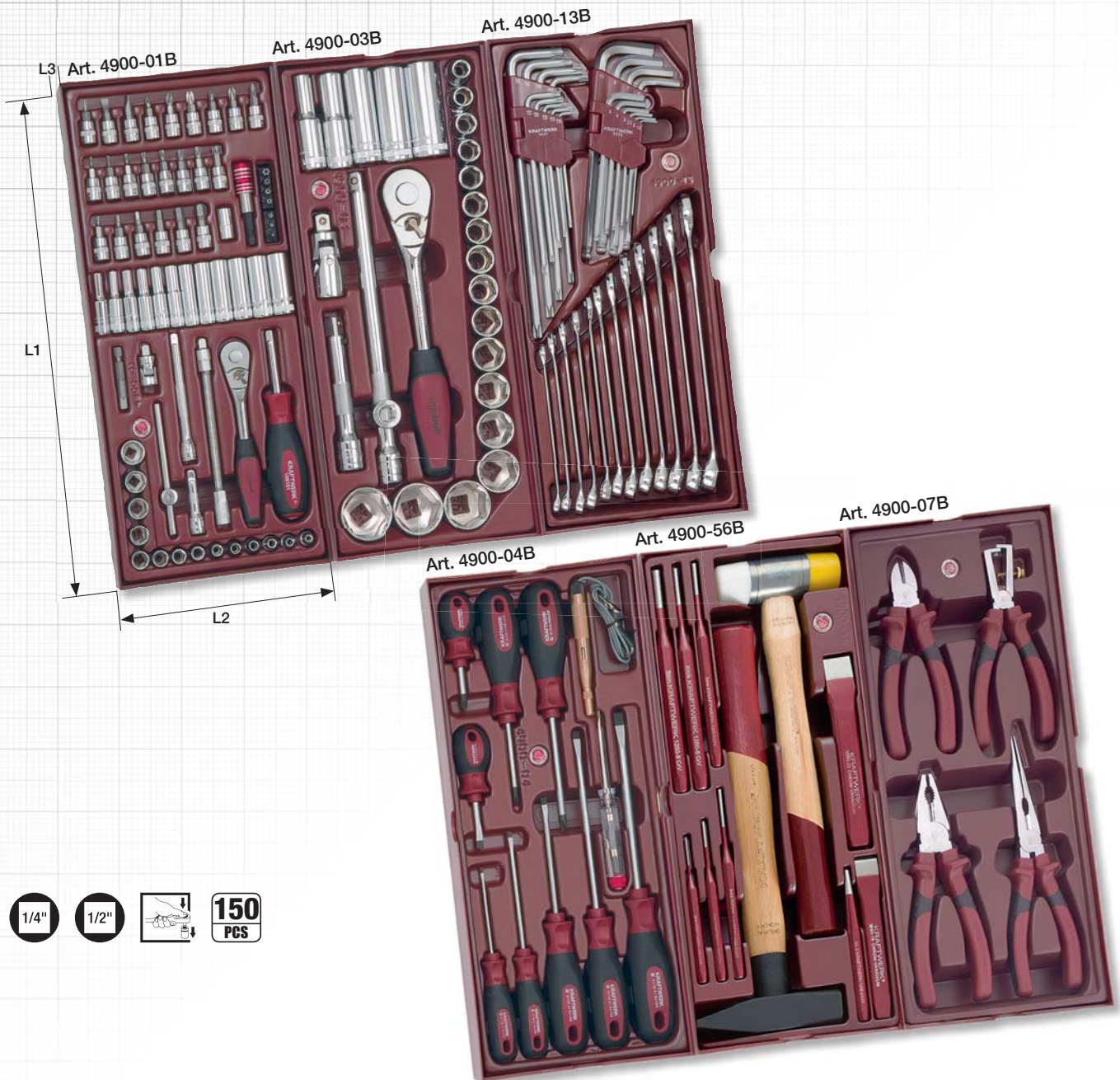

Werkzeug-Zusammenstellung

Basis-Sortiment für 2 Schubladen

Assortiment d'outils

de base pour 2 tiroirs

Assortimento di utensili

base per 2 cassetti

Art.	
4909	4900-01B, 4900-03B, 4900-13B, 4900-04B, 4900-56B, 4900-07B

↔ L1 402 × L2 173 × L3 48 mm

Werkzeug-Zusammenstellung

mit Werkstattwagen

Assortiment d'outils

avec servantes

Assortimento di utensili

con carrelli

	Art.
1	3907-4909
2	3908-4909
3	3909-4909
4	3905-4909
5	3934-4909
6	2905-4909
7	2907-4909
8	2904-4909





Werkzeug-Zusammenstellung

Basis-Sortiment für 3 Schubladen

Assortiment d'outils

de base pour 3 tiroirs

Assortimento di utensili

base per 3 cassetti

Art.	
4911	4900-01B, 4900-03B, 4900-04B, 4900-13B, 4900-14B, 4900-07B, 4900-56B, 4900-10B, 4900-11B

↔ L1 402 × L2 173 × L3 48 mm

Werkzeug-Zusammenstellung

mit Werkstattwagen

Assortiment d'outils

avec servantes

Assortimento di utensili

con carrelli

	Art.
1	3907-4911
2	3908-4911
3	3909-4911
4	3905-4911
5	3934-4911
6	2905-4911
7	2907-4911
8	2904-4911



Gigantische Werkstattausrüstung

mit besten Qualitätswerkzeugen in 24 COMPLETEO-Werkzeug-Einlagen.

Un équipement d'atelier très complet

avec des outils de qualité supérieure dans 24 coquilles COMPLETEO.

Un gigantesco assortimento d'utensili

con i migliori utensili di qualità in 24 vaschette COMPLETEO.



Art. 4920



Art. 4920F

Art.	
4920	4900-01B, 4900-02B, 4900-03B, 4900-38B, 4900-20B, 4900-19B, 4900-16B, 4900-22B, 4900-15B, 4900-13B, 4900-14B, 4900-40B, 4900-04B, 4900-05B, 4900-59B, 4900-11B, 4900-12B, 4900-53B, 4900-33B, 4900-57B1, 4900-09B, 4900-66B, 4900-10B, 4900-21B,
4920F	4900-01B, 4900-02B, 4900-03B, 4900-38B, 4900-20B, 4900-19B, 4900-16B, 4900-22B, 4900-18B, 4900-13B, 4900-14B, 4900-40B, 4900-04B, 4900-05B, 4900-59B, 4900-11B, 4900-12B, 4900-53B, 4900-33B, 4900-57B1, 4900-09B, 4900-66B, 4900-10B, 4900-21B,

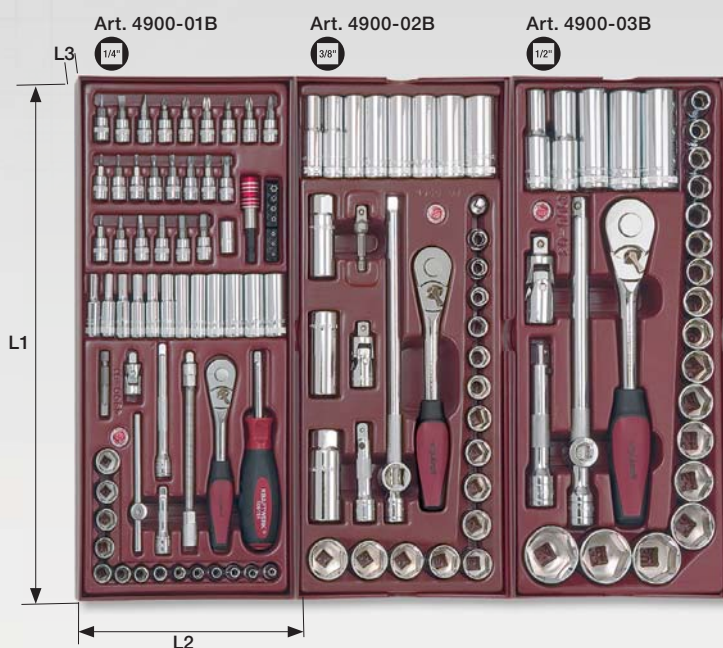

↔ L1 402 x L2 173 x L3 48 mm

Art. 4900-38B



Art. 4900-20B



Art. 4900-19B

Art. 4900-16B

Art. 4900-22B

Art. 4900-15B
(nur / seulement / solo 4920)



Art. 4900-13B



Art. 4900-14B



Art. 4900-40B



Art. 4900-04B



Art. 4900-05B



Art. 4900-59B



Art. 4900-11B



Art. 4900-12B



Art. 4900-53B



Art. 4900-33B



Art. 4900-57B1



Art. 4900-09B



HIGHTECH3C
 Made in Germany

4GRIP

Art. 4900-66B



Art. 4900-10B



Art. 4900-21B



Art. 4900-18B
 (nur / seulement / solo 4920F)



COMPLETO
 Serie 4900

**Die rollende Werkstatt -
gigantische Werkstatt-
ausrüstung**

mit besten Qualitätswerkzeugen in 24
COMPLETO-Werkzeug-Einlagen, verstaut
in 8 Schubladen des XXL-Roll-Werkbank/
Werkstattwagens.

**La servante d'atelier -
Un équipement
d'atelier très complet**

avec des outils de qualité supérieure dans
24 coquilles COMPLETEO - intégrées dans
8 tiroirs de la servante-établi EXTRA-LARGO.

**Il banco di lavoro rotabile -
Un gigantesco assortimento
d'utensili**

con i migliori utensili di qualità in 24
vaschette COMPLETEO dentro 8 cassetti
nel carrello EXTRA LARGO.

551
PCS Art. 4920

553
PCS Art. 4920F



Art.		
3936-4920	12	
3936-4920F	12	

nur / seulement / solo
3936-4920

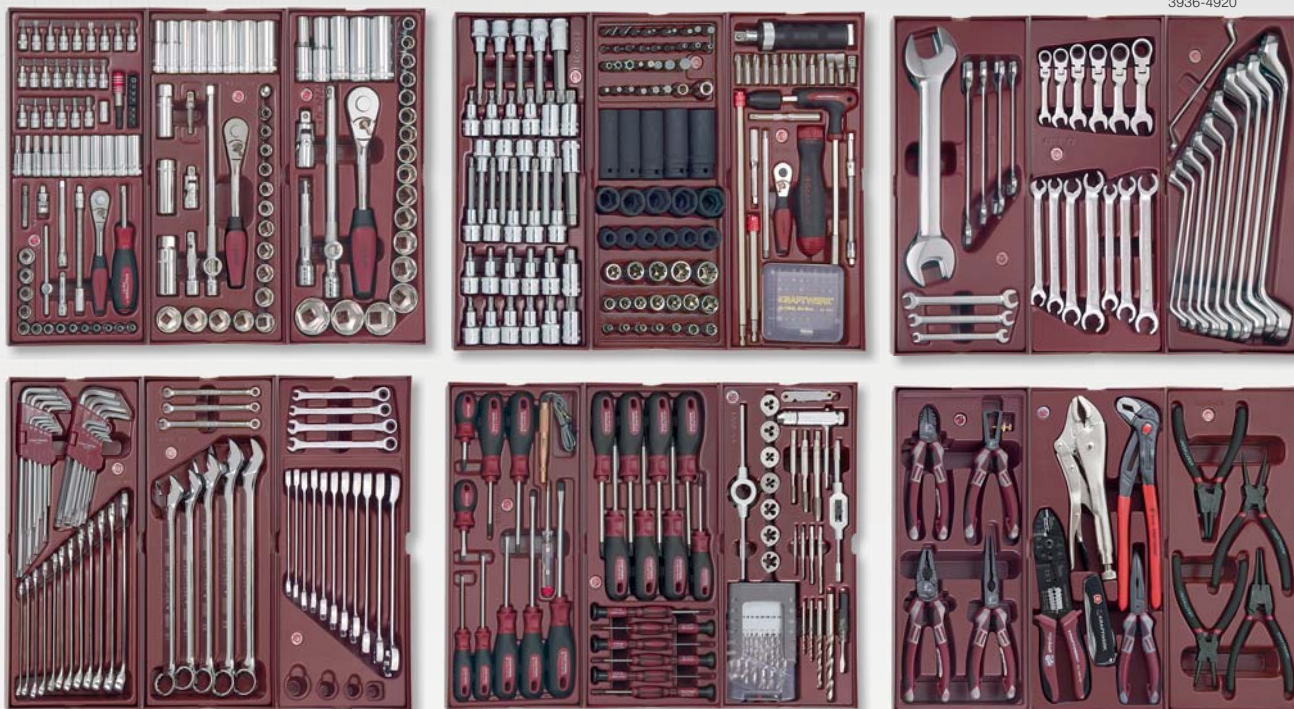

nur / seulement /
solo 3936-4920F

Art. 3936ES

9
PCS



COMPLETO
Serie 4900



Steckschlüssel-Schale
Coquille de douilles
 Assortimento di chiavi a bussola in vaschetta



Art.

4900-01B

↔ L1 402 × L2 173 × L3 48 mm

- | | | | | | |
|--|----|---|--|----|-----------------------------|
| | 15 | 3.5-4-4.5-5-5.5-6-7-8-9-10-11-12-13-14 mm | | 2 | 50 mm / 100 mm |
| | 12 | 4-4.5-5-5.5-6-7-8-9-10-11-12-13 mm | | | 150 mm |
| | 3 | 4-5.5-6.5 mm | | | 115 mm |
| | 3 | PH 1-2-3 | | | 1/4" ■ 1/4" |
| | 3 | PZ 1-2-3 | | 7 | T10-T15-T20-T25-T27-T30-T40 |
| | 8 | T8-T10-T15-T20-T25-T27-T30-T40 | | | 1/4" ○ 1/4" |
| | 6 | 3-4-5-6-7-8 mm | | | 1/4" ■ 1/4" |
| | | ○ 1/4" ○ 1/4" | | 45 | Art. 3200 |
| | | ○ 1/4" ■ 1/4" | | | |



Steckschlüssel-Schale
Coquille de douilles
 Assortimento di chiavi a bussola in vaschetta



Art.

4900-02B

↔ L1 402 × L2 173 × L3 48 mm

- | | | |
|--|----|---|
| | 15 | 8-9-10-11-12-13-14-15-16-17-18-19-21-22-24 mm |
| | 8 | 10-11-12-13-14-15-17-19 mm |
| | 3 | 16 mm / 18 mm / 21 mm |
| | | ○ 3/8" ■ 3/8" |
| | 2 | 75 mm / 250 mm |
| | | ○ 1/2" ■ 3/8" |
| | | ○ 3/8" ■ 1/4" |
| | | ■ 1/4" ■ 3/8" |

45 Art. 3210



Steckschlüssel-Schale
Coquille de douilles
Assortimento di chiavi a bussola in vaschetta

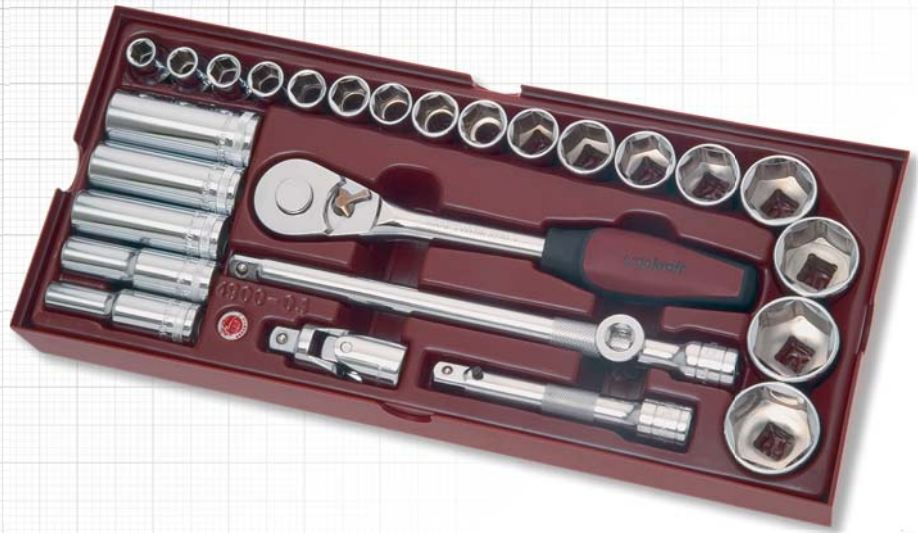

Art.
4900-03B

↔ L1 402 × L2 173 × L3 48 mm

	17	10-11-12-13-14-15-16-17-18 19-21-22-24-27-30-32-34 mm
	5	10-13-17-19-22 mm
	2	125 mm / 250 mm
		○ 1/2" ■ 1/2"
		○ 3/8" ■ 1/2"

45 Art. 3220



inch
Steckschlüssel-Schale
Zollmasse
Coquille de douilles en pouce
Assortimento di chiavi a bussola in pollici in vaschetta



Art.
4900-29B

↔ L1 402 × L2 173 × L3 48 mm

	9	3/16"-7/32"-1/4"-9/32"-5/16" 11/32"-3/8"-7/16"-1/2"
	9	3/16"-7/32"-1/4"-9/32"-5/16" 11/32"-3/8"-7/16"-1/2"
		○ 1/4" ■ 1/4"
	2	50 mm / 100 mm
		○ 3/8" ■ 1/4"

72 Art. 4009 **EXTREME**

	8	9/16"-5/8"-11/16"-3/4" 13/16"-7/8"-15/16"-1"
	3	9/16"-11/16"-3/4"
	2	5/8"-13/16"
		○ 3/8" ■ 3/8"
	2	75 mm / 250 mm
		○ 1/2" ■ 3/8"

72 Art. 4019 **EXTREME**

	9	1/16"-5/64"-3/32"-1/8"-5/32" 3/16"-1/4"-5/16"-3/8"
--	---	---



Bit-Stecknuss-Schale
 Coquille de douilles-embouts
 Assortimento di bussole
 giravite lunghe e corte
 in vaschetta



Art.
4900-38B

↔ L1 402 × L2 173 × L3 48 mm

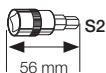

- 6 ⚙ T30-T40-T45-T50-T55-T60
- 6 ● 5-6-7-8-10-12 mm
- 6 ● M5-M6-M8-M10-M12-M14

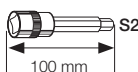

- 5 ⚙ T30-T40-T45-T50-T55
- 5 ● 6-7-8-10-12 mm
- 5 ● M5-M6-M8-M10-M12



Spezial-Bit-Stecknuss-Schale
 Coquille de douilles-embouts
 spéciales
 Assortimento di bussole ad
 inserto speciale in vaschetta



Art.
4900-58B

↔ L1 402 × L2 173 × L3 48 mm

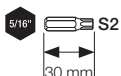

- 9 ⚙ T20-T25-T27-T30-T40
T45-T50-T55-T60
- 7 ● 4-5-6-7-8-10-12 mm
- 5 ● M5-M6-M8-M10-M12



- 3 ⚙ T30-T40-T45



- 9 ⚙ T20-T25-T27-T30-T40
T45-T50-T55-T60
- 7 ● 4-5-6-7-8-10-12 mm
- 5 ● M5-M6-M8-M10-M12

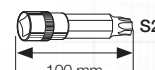

- ⚙ T70

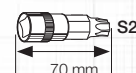

- ⚙ T80



- 3/8" ○ 5/16"
- 1/2" ○ 5/16"

38
PCS

Durchsteck-Steckschlüssel-
Schale

Coquille de douilles
débouchées

Assortimento chiavi a bussola
in serie forate in vaschetta

Art.

4900-49B

↔ L1 402 × L2 173 × L3 48 mm



GEAR RATCHET



- | | | |
|----|-------|----------------------------------|
| 9 | 13 mm | 3.5-4-4.5-5-5.5-6-7-8-9 mm |
| 10 | 20 mm | 10-11-12-13-14-15-16-17-18-19 mm |
| 8 | 30 mm | 20-21-22-24-27-30-32-34 mm |



- | | | |
|-------|-------|----------------|
| 13 mm | 75 mm | |
| 20 mm | 75 mm | |
| 2 | 30 mm | 75 mm / 155 mm |



13 mm × 1/4"

20 mm × 3/8"

30 mm × 1/2"



13 mm × 1/4"



13 mm Art. 590000

20 mm Art. 600000

30 mm Art. 610000

1/4" 3/8" 1/2" 5/16" **CrMo** **71**
PCS

Spezial-Steckschlüssel-/
Bit-Schale

Coquille de douilles
et embouts spéciaux

Assortimento di chiavi a bussola
a macchina e inserti in vaschetta

Art.

4900-20B

↔ L1 402 × L2 173 × L3 48 mm



6 E4-E6-E7-E8-E10-E11



7 E10-E11-E12-E14-E16-E18-E20



5 E16-E18-E20-E22-E24



11 9-10-11-13-14-17-19-21-22-23-24 mm



5 17-19-21-22-24 mm



3/8" 5/16"



1/2" 5/16"



3 8-10-12 mm

2 PH 3-4

2 PZ 3-4

6 T40-T45-T47-T50-T55-T60

12 T10-T15-T20-T25-T27-T30
T40-T45-T50-T55-T60-T70

5 6-8-10-12-14 mm

4 M6-M8-M10-M12





Universal-Schlag-Steckschlüssel-Schale
Coquille universelle de douilles impact
 Assortimento universale di chiavi a bussola a macchina



Art.	
4900-70B	1/2"

↔ L1 402 × L2 173 × L3 48 mm

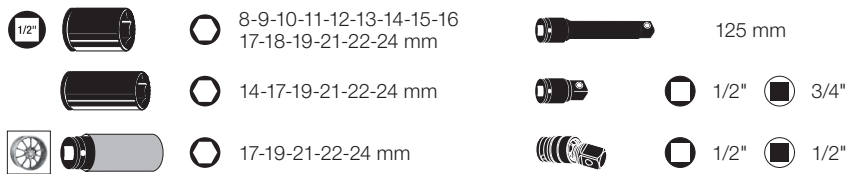

Schlagschrauber-Schale
Coquille de clé à choc pneumatique
 Assortimento con avvitatore a percussione



Art.		
4900-71B	1/2"	3833
4900-71B1	1/2"	3834

↔ L1 402 × L2 173 × L3 48 mm

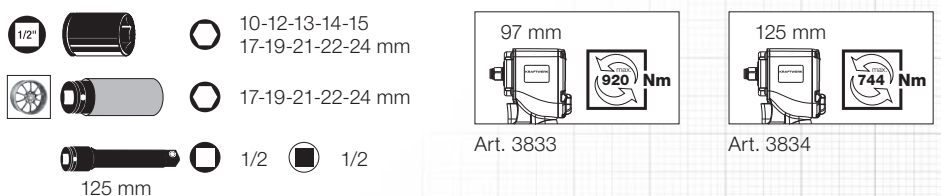

31
PCS

**Gabelring-/Innensechskant-/TX-
Winkel-Stiftschlüssel-Schale**

*Coquille de clés combinées et
de clés mâles hexagonales et TX*

Assortimento di chiavi
combinate, maschi esagonali
e TX in vaschetta



Art.

4900-13B

↔ L1 402 x L2 173 x L3 48 mm

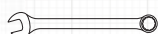

DIN 3113

Art. 3508	8 mm	Art. 3514	14 mm
Art. 3509	9 mm	Art. 3515	15 mm
Art. 3510	10 mm	Art. 3516	16 mm
Art. 3511	11 mm	Art. 3517	17 mm
Art. 3512	12 mm	Art. 3518	18 mm
Art. 3513	13 mm	Art. 3519	19 mm



DIN 2936 S2

Art. 3602
1.5-2-2.5-3-4-5-6-7-8-10 mm



XXL S2

Art. 3607
T10-T15-T20-T25-T27
T30-T40-T45-T50

8
PCS

Gabelringschlüssel-Schale

Coquille de clés combinées

Assortimento di chiavi
combinate in vaschetta



Art.

4900-14B

↔ L1 402 x L2 173 x L3 48 mm



DIN 3113

Art. 3505	5.5 mm
Art. 3506	6 mm
Art. 3507	7 mm
Art. 3520	20 mm
Art. 3521	21 mm
Art. 3522	22 mm
Art. 3523	23 mm
Art. 3524	24 mm

COMPLETOSerie **4900**COMBINATION
CLICKRAFT**15**
PCS

inch

Gabelringschlüssel-Schale
Zollmasse*Coquille de clés
combinées en pouce*Assortimento di chiavi com-
binate in pollici in vaschetta

Art.

4900-30B

L1 402 x L2 173 x L3 48 mm

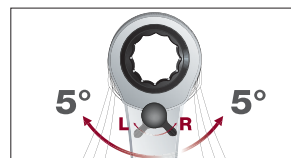
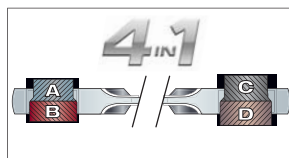
**A** 5/16"
B 3/8" Art. 3404-51612**A** 9/16"
B 5/8" Art. 3404-91634**C** 7/16"
D 1/2"**C** 11/16"
D 3/4"Art. 3587 1/4"
Art. 3588 5/16"
Art. 3589 3/8"
Art. 3590 7/16"
Art. 3591 1/2"
Art. 3592 9/16"
Art. 3593 5/8"Art. 3594 11/16"
Art. 3595 3/4"
Art. 3596 13/16"
Art. 3597 7/8"
Art. 3598 15/16"
Art. 3599 1"**19**
PCSRatschen-Ring-
gabelschlüssel-Schale*Coquille de clés
combinées à cliquet*Assortimento di chiavi com-
binate a cricchetto in vaschetta

Art.

4900-17B

L1 402 x L2 173 x L3 48 mm

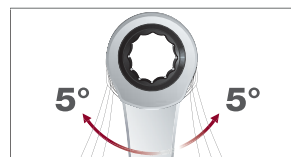
COMBINATION
CLICKRAFTArt. 3405 5.5 mm
Art. 3406 6 mm
Art. 3407 7 mm
Art. 3408 8 mm
Art. 3409 9 mm
Art. 3410 10 mm
Art. 3411 11 mm
Art. 3412 12 mm
Art. 3413 13 mmArt. 3414 14 mm
Art. 3415 15 mm
Art. 3416 16 mm
Art. 3417 17 mm
Art. 3418 18 mm
Art. 3419 19 mmArt. 3691 1/4" 10 mm
Art. 3692 3/8" 13 mm
Art. 3693 1/2" 19 mm
Art. 2694 1/4" 10 mm

15
PGS 

Doppel-Ratschen-Ring-
gabelschlüssel-Schale
Coquille de clés
combinées à cliquet double
Assortimento di chiavi
combinate a doppio
cricchetto in vaschetta



COMBINATION *plus*
DOUBLE RATCHET
CLICKRAFT

Art.

4900-40B

↔ L1 402 × L2 173 × L3 48 mm



Art. 3405	5.5 mm
Art. 3406	6 mm
Art. 3407	7 mm

Art. 3401-08	8 mm
Art. 3401-09	9 mm
Art. 3401-10	10 mm
Art. 3401-11	11 mm
Art. 3401-12	12 mm
Art. 3401-13	13 mm
Art. 3401-14	14 mm
Art. 3401-15	15 mm
Art. 3401-16	16 mm
Art. 3401-17	17 mm
Art. 3401-18	18 mm
Art. 3401-19	19 mm

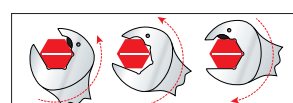

Option / Option / Opzionali

	Art. 3691	1/4" ■ 10 mm	
	Art. 3692	3/8" ■ 13 mm	
	Art. 3693	1/2" ■ 19 mm	
	Art. 2694	1/4" ○ 10 mm	



Video
KRAFTWERKtools.com/video/double-ratchet

12
PGS 

90° Ratschen-Ringgabel-
schlüssel-Schale, extra lang
Coquille de clés combinées
à cliquet 90°, extra longues
Assortimento di chiavi
combinate a cricchetto 90°,
extra lunghi in vaschetta



LARGO 90
CLICKRAFT

Art.

4900-28B

↔ L1 402 × L2 173 × L3 48 mm

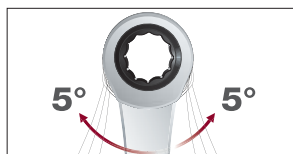

Art. 4405-08	8 mm
Art. 4405-09	9 mm
Art. 4405-10	10 mm
Art. 4405-11	11 mm
Art. 4405-12	12 mm
Art. 4405-13	13 mm

Art. 4405-14	14 mm
Art. 4405-15	15 mm
Art. 4405-16	16 mm
Art. 4405-17	17 mm
Art. 4405-18	18 mm
Art. 4405-19	19 mm

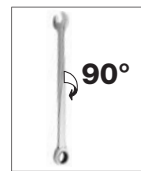

COMPLETOSerie **4900**REVERSIBLE
CLICKRAFT**14**
PCS

Umschaltbare Ratschen-
Ringgabelschlüssel-Schale
*Coquille de clés combinées
à cliquet réversible*

Assortimento di chiavi
combinata a cricchetto
reversibili in vaschetta



Art.

4900-47B

↔ L1 402 × L2 173 × L3 48 mm

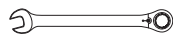
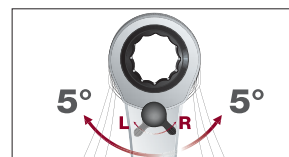

Art. 3404-08	8 mm	Art. 3404-15	15 mm
Art. 3404-09	9 mm	Art. 3404-16	16 mm
Art. 3404-10	10 mm	Art. 3404-17	17 mm
Art. 3404-11	11 mm	Art. 3404-18	18 mm
Art. 3404-12	12 mm	Art. 3404-19	19 mm
Art. 3404-13	13 mm	Art. 3404-22	22 mm
Art. 3404-14	14 mm	Art. 3404-24	24 mm

14
PCS

Flexible Ratschen-Ring-
gabelschlüssel-Schale
*Coquille de clés combinées
à cliquet articulées*

Assortimento di chiavi a
cricchetto snodate in vaschetta

FLEX
CLICKRAFT

Art.

4900-46B

↔ L1 402 × L2 173 × L3 48 mm

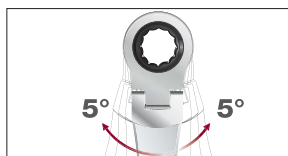

Art. 3403-08	8 mm	Art. 3403-15	15 mm
Art. 3403-09	9 mm	Art. 3403-16	16 mm
Art. 3403-10	10 mm	Art. 3403-17	17 mm
Art. 3403-11	11 mm	Art. 3403-18	18 mm
Art. 3403-12	12 mm	Art. 3403-19	19 mm
Art. 3403-13	13 mm	Art. 3403-22	22 mm
Art. 3403-14	14 mm	Art. 3403-24	24 mm

12
PCS



Winkel-Ratschen-Ring-
gabelschlüssel-Schale
*Coquille de clés combinées
à cliquet à angle*
Assortimento di chiavi
combinata a cricchetto
orientabili in vaschetta

ANGLE
CLICKRAFT



Art.

4900-41B

↕ L1 402 × L2 173 × L3 48 mm

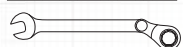
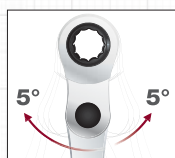

Art. 3402-08	8 mm
Art. 3402-09	9 mm
Art. 3402-10	10 mm
Art. 3402-11	11 mm
Art. 3402-12	12 mm
Art. 3402-13	13 mm

Art. 3402-14	14 mm
Art. 3402-15	15 mm
Art. 3402-16	16 mm
Art. 3402-17	17 mm
Art. 3402-18	18 mm
Art. 3402-19	19 mm

Option / Option / Opzionali



Art. 3691	1/4" ■ 10 mm
Art. 3692	3/8" ■ 13 mm
Art. 3693	1/2" ■ 19 mm



Art. 2694	1/4" ○ 10 mm
-----------	--------------



10
PCS

Doppelgabelschlüssel-Schale
Coquille de clés à fourche
Assortimento di chiavi fisse a
forchetta in vaschetta



Art.

4900-16B

↕ L1 402 × L2 173 × L3 48 mm

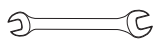

DIN 3110

Art. 3560	6 × 7 mm	Art. 3565	16 × 17 mm
Art. 3561	8 × 9 mm	Art. 3566	18 × 19 mm
Art. 3562	10 × 11 mm	Art. 3567	21 × 22 mm
Art. 3563	12 × 13 mm	Art. 3568	24 × 27 mm
Art. 3564	14 × 15 mm	Art. 3569	30 × 32 mm

11
PCS

Doppelringschlüssel-Schale
Coquille de clés polygonales
Assortimento di chiavi poligonali doppie in vaschetta



Art.

4900-15B

↔ L1 402 × L2 173 × L3 48 mm



DIN 838

Art. 3480	6 × 7 mm	Art. 3486	18 × 19 mm
Art. 3481	8 × 9 mm	Art. 3487	20 × 22 mm
Art. 3482	10 × 11 mm	Art. 3488	21 × 23 mm
Art. 3483	12 × 13 mm	Art. 3489	24 × 27 mm
Art. 3484	14 × 15 mm	Art. 3491	30 × 32 mm
Art. 3485	16 × 17 mm		

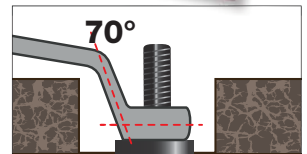

13
PCS



Offener Bremsschlüssel/
Flexible Stubby-Ratschen-
Ringgabelschlüssel-Schale
*Coquille de clés à tuyauter/
clés combinées à cliquet
articulées extra courtes*
Assortimento di chiavi per
raccordi tubi e chiavi
combinati a cricchetto
snodate corte in vaschetta



STUBBY FLEX
CLICKRAFT

Art.

4900-22B

↔ L1 402 × L2 173 × L3 48 mm

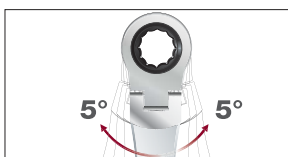

180°

Art. 3403-08S	8 mm
Art. 3403-10S	10 mm
Art. 3403-11S	11 mm
Art. 3403-12S	12 mm
Art. 3403-13S	13 mm
Art. 3403-14S	14 mm

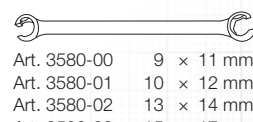

Art. 3580-00	9 × 11 mm
Art. 3580-01	10 × 12 mm
Art. 3580-02	13 × 14 mm
Art. 3580-03	15 × 17 mm
Art. 3580-04	3/8" × 7/16"
Art. 3580-05	1/2" × 9/16"
Art. 3580-06	5/8" × 11/16"



13
PGS

Pfeifenkopfschlüssel-Schale

Coquille de clés à pipe débouchées

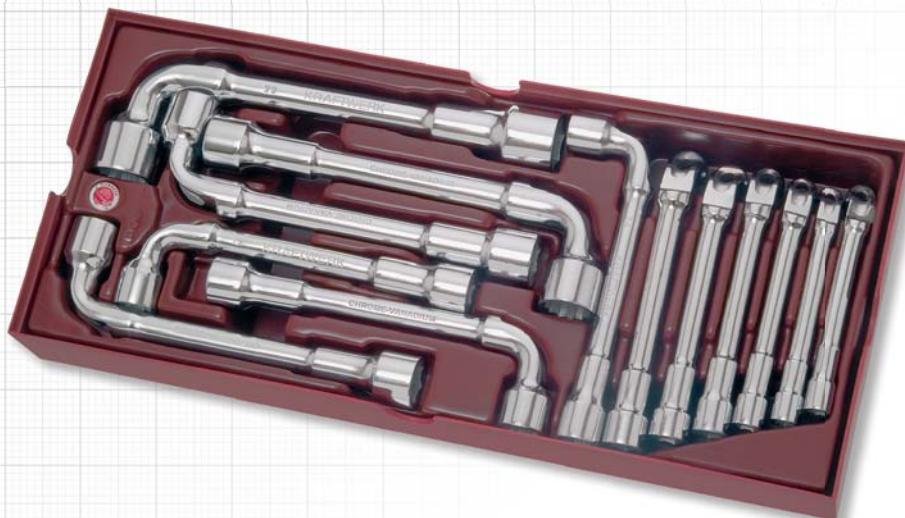
Assortimento di chiavi a pipa in vaschetta



Art.	
4900-18B	
4900-48B	

↔ L1 402 × L2 173 × L3 48 mm

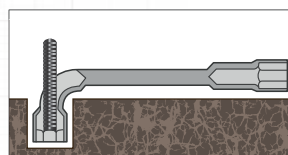

4900-18B

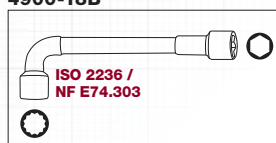

Art. 2598-08	8 mm
Art. 2598-09	9 mm
Art. 2598-10	10 mm
Art. 2598-11	11 mm
Art. 2598-12	12 mm
Art. 2598-13	13 mm
Art. 2598-14	14 mm

Art. 2598-15	15 mm
Art. 2598-16	16 mm
Art. 2598-17	17 mm
Art. 2598-18	18 mm
Art. 2598-19	19 mm
Art. 2598-22	22 mm

4900-48B

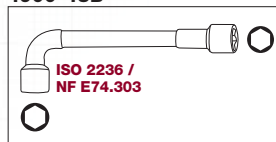

Art. 2597-08	8 mm
Art. 2597-09	9 mm
Art. 2597-10	10 mm
Art. 2597-11	11 mm
Art. 2597-12	12 mm
Art. 2597-13	13 mm
Art. 2597-14	14 mm

Art. 2597-15	15 mm
Art. 2597-16	16 mm
Art. 2597-17	17 mm
Art. 2597-18	18 mm
Art. 2597-19	19 mm
Art. 2597-22	22 mm

14
PGS

Rohrsteckschlüssel-Schale

Coquille de clés en tube droites

Assortimento di chiavi a tubo in vaschetta



Art.
4900-23B

↔ L1 402 × L2 173 × L3 48 mm



DIN 896

Art. 2599-0607	6 × 7 mm
Art. 2599-0809	8 × 9 mm
Art. 2599-1011	10 × 11 mm
Art. 2599-1213	12 × 13 mm
Art. 2599-1415	14 × 15 mm
Art. 2599-1617	16 × 17 mm

Art. 2599-1819	18 × 19 mm
Art. 2599-2022	20 × 22 mm
Art. 2599-2123	21 × 23 mm
Art. 2599-2427	24 × 27 mm
Art. 2599-2528	25 × 28 mm
Art. 2599-3032	30 × 32 mm

Art. 2599-1012	210 mm
Art. 2599-3457	165 mm

9
PCS

Doppelgelenkschlüssel-Schale
Coquille de clés double-articulées
Assortimento di chiavi doppie a bussola in vaschetta



Art.

4900-27B

↕ L1 402 × L2 173 × L3 48 mm

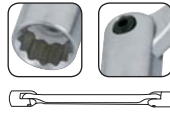

Art. 2590-0809 8 × 9 mm
Art. 2590-1011 10 × 11 mm
Art. 2590-1213 12 × 13 mm
Art. 2590-1415 14 × 15 mm
Art. 2590-1617 16 × 17 mm
Art. 2590-1819 18 × 19 mm

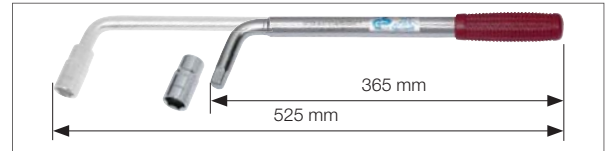

Art. 2590-3814 1/4" × 3/8"

Art. 2585-1719 1/2"

17 × 19 mm

13
PCS

Schraubendreher-Schale
VSM Swiss Norm
Coquille de tournevis VSM norme Suisse
Assortimento di giraviti VSM norma svizzera in vaschetta



Art.

4900-50B

↕ L1 402 × L2 173 × L3 48 mm

Art. 2100-0 0.4 × 2.5 mm
Art. 2100-1 0.5 × 3.5 mm
Art. 2100-2 0.6 × 4 mm
Art. 2100-3 0.8 × 5.5 mm
Art. 2100-4 1.0 × 6.5 mm
Art. 2100-5 1.2 × 8 mm
Art. 2100-6 1.6 × 10 mm

Art. 2190-1 PH1
Art. 2190-2 PH2
Art. 2190-3 PH3

Art. 2192-1 PZ1
Art. 2192-2 PZ2

100-250 V
Art. 2138

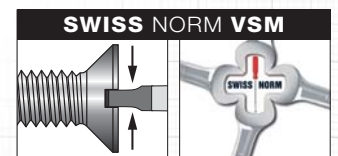

1/4" 1/4" 16 PCS





Schraubendreher-Schale
PB Swissgrip
Coquille de tournevis
PB Swissgrip
Assortimento di giraviti
PB Swissgrip in vaschetta



Art.

4900-60B

↔ L1 402 x L2 173 x L3 48 mm

- 
Art. PB 8100 5 1.2 x 8 mm
Art. PB 8100 4-140 1.0 x 6.5 mm
Art. PB 8100 3-120 0.8 x 5.5 mm
Art. PB 8100 2-100 0.6 x 4.0 mm
Art. PB 8100 1- 90 0.5 x 3.5 mm
- 
+ Art. PB 8190 1- 80 PH1 x 80
Art. PB 8190 2-100 PH2 x 100/6
- 
Art. PB 8451 10 x 30 mm
- 
Art. PB 1750 110-250 V

PB SWISS TOOLS



1/4" S2 T10-T15-T20-T25-T27-T30-T40

S2 quality 11 PCS

Schraubendreher-Schale
Coquille de tournevis
Assortimento di giraviti
in vaschetta







ergokraft

Art.

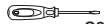
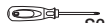
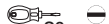
4900-04B

↔ L1 402 x L2 173 x L3 48 mm

- 
S2 Art. 4110-1 0.6 x 3 mm
Art. 4110-2 0.8 x 4 mm
Art. 4110-3 1.0 x 5 mm
Art. 4110-4 1.1 x 6 mm
Art. 4110-5 1.2 x 8 mm
- 
+ Art. 4115-1 PH 1
Art. 4115-2 PH 2
- 
S2 Art. 4112-2 1.1 x 6 mm
- 
+ Art. 4117-2 PH 2
- 
GS Art. 2138 100-250 V
- 
Art. 2139 12 V

COMPLETO Serie 4900 ergokraft

S2 quality **14** PCS

Schraubendreher-Schale
Coquille de tournevis
Assortimento di giraviti
in vaschetta

Art.

4900-05B

↔ L1 402 × L2 173 × L3 48 mm



 S2

★	Art. 4125-08	T8
	Art. 4125-10	T10
	Art. 4125-15	T15
	Art. 4125-20	T20
	Art. 4125-25	T25
	Art. 4125-27	T27
	Art. 4125-30	T30
	Art. 4125-40	T40

 S2

○	Art. 3177-20	0.45 × 2.0 mm
	Art. 3177-24	0.5 × 2.4 mm
	Art. 3177-30	0.6 × 3.0 mm
	Art. 3177-35	0.65 × 3.5 mm

 S2

+	Art. 3177-0	PH 0
	Art. 3177-1	PH 1

S2 quality **8** PCS

Schlagkappen-Schraubendreher-Schale
Coquille de tournevis de frappe
Assortimento di giraviti
martellabili in vaschetta

Art.

4900-54B

↔ L1 402 × L2 173 × L3 48 mm

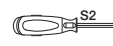

ergokraft

 S2

○	Art. 4140-3	5.5 × 100 mm	5.5 mm
	Art. 4140-4	6.5 × 125 mm	6.5 mm
	Art. 4140-5	8.0 × 150 mm	8.0 mm
	Art. 4140-6	10.0 × 175 mm	10.0 mm

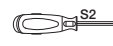
 S2

+	Art. 4145-1	PH1 × 75 mm	5.0 mm
	Art. 4145-2	PH2 × 100 mm	6.0 mm

 S2

+	Art. 4150-1	PZ1 × 75 mm	5.0 mm
	Art. 4150-2	PZ2 × 100 mm	6.0 mm

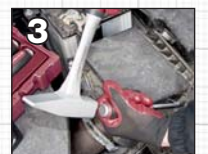

S2
quality

8
PCS

Steckschlüssel mit
Griff-Schale
*Coquille de clés à douille
emmanchée*
Assortimento di giraviti
a bussola in vaschetta

Art.

4900-31B

↕ L1 402 × L2 173 × L3 48 mm



ergokraft

	Art. 4127-055	5.5 mm
S2	Art. 4127-06	6 mm
	Art. 4127-07	7 mm
	Art. 4127-08	8 mm
	Art. 4127-10	10 mm
	Art. 4127-11	11 mm
	Art. 4127-12	12 mm
	Art. 4127-13	13 mm

S2
quality

7
PCS

Kugelkopf-T-Griff-
Schraubendreher-Schale
*Coquille de tournevis
mâles à tête sphérique en T*
Assortimento di chiavi
esagonali a T in vaschetta
con testa scorrevole

Art.

4900-25B

↕ L1 402 × L2 173 × L3 48 mm



	Art. 3636-3	3 mm
S2	Art. 3636-4	4 mm
	Art. 3636-5	5 mm
	Art. 3636-6	6 mm
	Art. 3636-7	7 mm
	Art. 3636-8	8 mm
	Art. 3636-10	10 mm



ergokraft



TX-T-Griff-Schraubendreher-Schale

Coquille de tournevis TX en T

Assortimento di chiavi TX a T in vaschetta

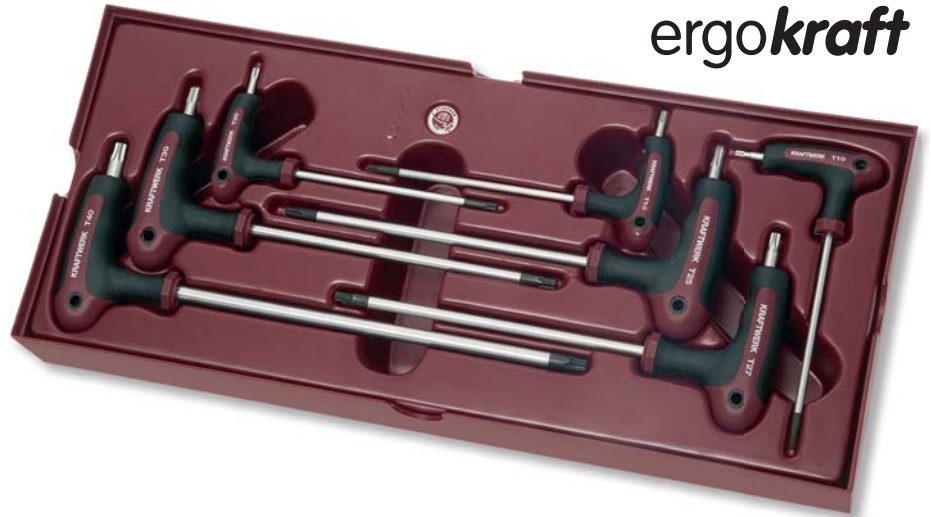

Art.

4900-26B

↔ L1 402 × L2 173 × L3 48 mm

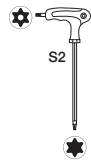

Art. 3637-10	T10
Art. 3637-15	T15
Art. 3637-20	T20
Art. 3637-25	T25
Art. 3637-27	T27
Art. 3637-30	T30
Art. 3637-40	T40



T-Griff-Stiftschlüssel-Schale Innensechskant

Coquille de clés mâles hexagonales en T

Assortimento di chiavi esagonali a T in vaschetta con testa scorrevole



Art.

4900-35B

↔ L1 402 × L2 173 × L3 48 mm

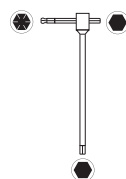

Art. 2593-02	2 mm
Art. 2593-025	2.5 mm
Art. 2593-03	3 mm
Art. 2593-04	4 mm
Art. 2593-05	5 mm
Art. 2593-06	6 mm
Art. 2593-07	7 mm
Art. 2593-08	8 mm
Art. 2593-10	10 mm

9
PCS

**TX-T-Griff-Stiftschlüssel-
Schale**

Coquille de clés TX en T

Assortimento di chiavi TX a T
in vaschetta con impugnatura
scorrevole



Art.

4900-36B

↔ L1 402 × L2 173 × L3 48 mm

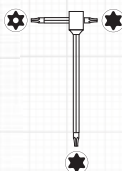

- | | |
|--------------|-----|
| Art. 2594-10 | T10 |
| Art. 2594-15 | T15 |
| Art. 2594-20 | T20 |
| Art. 2594-25 | T25 |
| Art. 2594-27 | T27 |
| Art. 2594-30 | T30 |
| Art. 2594-40 | T40 |
| Art. 2594-45 | T45 |
| Art. 2594-50 | T50 |

85
PCS

**Universal-Bit-Ratschen- und
Schraubwerkzeug-Schale**

*Coquille d'outils universels
avec cliquet et embouts*

Assortimento universale
di inserti e giravite a
percussione in vaschetta



GEARDRIVER

Art.

4900-19B

↔ L1 402 × L2 173 × L3 48 mm



- | | | |
|--|------------------|--------------------|
| 6 4-4.5-5.5-6-6.5-8 mm | 1/4" 1/4" | 4 6-8-10-12 mm |
| 4 PH 1-2-3-4 | 1/4" 1/4" | 4 PH 1-2-3-4 |
| 4 PZ 1-2-3-4 | 1/4" 1/4" | 4 T30-T40-T45-T50 |
| 8 T8-T10-T15-T20
T-25-T27-T30-T40 | Art. 3766 150 mm | 3/8" 5/16" |
| 8 T8-T10-T15-T20
T-25-T27-T30-T40 | Art. 3767 300 mm | 5/16" 3/8" |
| 6 3-4-5-6-7-8 mm | 90 mm | 90 mm |
| 6 2-2.5-3-4-5-6 mm | Art. 3634 | 150 mm |
| 6 5/64"-3/32"-7/64"
1/8"-9/64"-5/32" | Art. 3798 | Art. 2035S |
| 3 Nos. 6-8-10 | | |
| 4 Nos. 1-2-3-4 | | |
| 4 Nos. 4-6-8-10 | | |



Elektriker-Steckschlüssel- und Innensechskantschlüssel-Schale VDE

mit voll isolierter VDE-Umschaltknarre 1000V





Coquille de clés mâles et douilles d'électricien VDE

avec cliquet réversible VDE entièrement isolé 1000V

Assortimento di chiavi esagonali e chiavi a bussola VDE in vaschetta

con chiave a cricchetto reversibile completamente isolato 1000V



	8	8-10-12-13-14-17-19-22 mm		
	Art. 3136-025	2.5 × 126 mm		
	Art. 3136-03	3.0 × 126 mm		
	Art. 3136-04	4.0 × 160 mm		
	Art. 3136-05	5.0 × 160 mm		
	Art. 3136-06	6.0 × 200 mm		
	Art. 3136-08	8.0 × 200 mm		
	Art. 207150V	3/8" × 150 mm		
	Art. 3210V	200 mm		



Art.
4900-61B

↔ L1 402 × L2 173 × L3 48 mm

8
PCS

Elektriker-Steckschlüssel mit Griff-Schale VDE

Coquille de clés à douille emmanchée d'électricien VDE

Assortimento di giraviti a bussola VDE 1000V in vaschetta, 8 pezzi



Art.
4900-62B

↔ L1 402 × L2 173 × L3 48 mm

	Art. 3138-07	7.0 × 125 mm
	Art. 3138-08	8.0 × 125 mm
	Art. 3138-09	9.0 × 125 mm
	Art. 3138-10	10.0 × 125 mm
	Art. 3138-11	11.0 × 125 mm
	Art. 3138-12	12.0 × 125 mm
	Art. 3138-13	13.0 × 125 mm
	Art. 3138-14	14.0 × 125 mm



8
PCS

Elektriker-Schraubendreher-Schale VDE

Coquille de tournevis d'électricien VDE



Assortimento di giraviti VDE in vaschetta



Art.

4900-63B

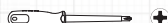
↕ L1 402 × L2 173 × L3 48 mm

	Art. 3132-1	2.5 × 75 mm
	Art. 3132-4	4.0 × 100 mm
	Art. 3132-5	5.5 × 125 mm
	Art. 3132-6	6.5 × 150 mm
	Art. 3135-0	PH0 × 60 mm
	Art. 3135-1	PH1 × 80 mm
	Art. 3135-2	PH2 × 100 mm
	Art. 2138	100-250 V



1000 V
IEC 60900

10
PCS

Elektriker-TX

Schraubendreher-Schale VDE
mit Bohrung an der Spitze für TX-Schrauben mit und ohne Sicherungsstift

Coquille de tournevis TX d'électricien VDE

avec pointe percée, pour vis TX normales et TX vis de sécurité

Assortimento di giraviti TX VDE in vaschetta

con perforazione sulla punta, per viti TX normali e viti TX con pin di sicurezza



Art.

4900-64B

↕ L1 402 × L2 173 × L3 48 mm

	Art. 3133-06	T6 × 100 mm
	Art. 3133-07	T7 × 100 mm
	Art. 3133-08	T8 × 100 mm
	Art. 3133-10	T10 × 100 mm
	Art. 3133-15	T15 × 100 mm
	Art. 3133-20	T20 × 100 mm
	Art. 3133-25	T25 × 125 mm
	Art. 3133-27	T27 × 125 mm
	Art. 3133-30	T30 × 150 mm
	Art. 3133-40	T40 × 175 mm



1000 V
IEC 60900

COMPLETOSerie **4900**
HYBRID**10**
PCS

Elektriker-Innensechskant-Schraubendreher- und Winkelstiftschlüssel-Schale VDE
Coquille de clés mâles et tournevis à six pans creux d'électricien VDE

Assortimento di chiavi e giraviti maschio esagonali VDE in vaschetta

Art.

4900-65B
 L1 402 × L2 173 × L3 48 mm
**1000 V**
IEC 60900

Art. 3134-025	2.5 × 100 mm
Art. 3134-03	3.0 × 100 mm
Art. 3134-04	4.0 × 125 mm
Art. 3134-05	5.0 × 150 mm
Art. 3134-06	6.0 × 175 mm
Art. 3134-08	8.0 × 200 mm



Art. 3136-03	3.0 × 126 mm
Art. 3136-04	4.0 × 160 mm
Art. 3136-05	5.0 × 160 mm
Art. 3136-06	6.0 × 200 mm

6
PCS

Elektriker-Zangen- und Schneidwerkzeug-Schale VDE
Coquille de pinces et outils de coupe d'électricien VDE

Assortimento di pinze ed utensili da taglio VDE in vaschetta

Art.

4900-67B
 L1 402 × L2 173 × L3 48 mm
**ergokraft**

Art. 3281-180V	180 mm
DIN ISO 5746	



Art. 3282-160V	160 mm
DIN ISO 5749	



Art. 3285-200V	200 mm
DIN ISO 5745	



Art. 2251V	
------------	--



Art. 3321V	
------------	--



4pcs. Art. 3321-4V	
--------------------	--

**1000 V**
IEC 60900

4
PGS

Elektriker-Zangen-Schale VDE
*Coquille de pinces
d'électricien VDE*
Assortimento di pinze VDE
per elettricista in vaschetta



Art.

4900-43B

↔ L1 402 × L2 173 × L3 48 mm



Art. 4211-180 180 mm **K C H**
DIN ISO 5746



Art. 4212-160 160 mm **K C H**
DIN ISO 5749



Art. 4215-205 200 mm **C H**
DIN ISO 5745



Art. 4219-160 160 mm
DIN ISO 5232

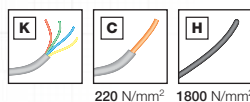

Made in Germany



1000 V
IEC 60900

4
PGS

Elektriker-Zangen-Schale VDE
*Coquille de pinces
d'électricien VDE*
Assortimento di pinze VDE
per elettricista in vaschetta



ergokraft

Art.

4900-42B

↔ L1 402 × L2 173 × L3 48 mm



Art. 3281-180V 180 mm
DIN ISO 5746



Art. 3282-160V 160 mm
DIN ISO 5749



Art. 3285-200V 205 mm
DIN ISO 5745



Art. 3289-160V 160 mm
DIN ISO 5232



1000 V
IEC 60900

COMPLETO Serie 4900

HIGHTECH

4
PCS

Industrie-Zangen-Schale
mit 3-Komponenten-Griffen

*Coquille de pinces industrielles
avec des manches 3-composants*

Assortimento di pinze
industriali in vaschetta
con manico in 3 componenti

Art.

4900-33B

↔ L1 402 × L2 173 × L3 48 mm



Made in Germany



Art. 4271-180
DIN ISO 5746

180 mm **K C H**



Art. 4272-160
DIN ISO 5749

160 mm **K C H**



Art. 4275-205
DIN ISO 5745

205 mm **C H**



Art. 4279-160
DIN ISO 5232

160 mm



220 N/mm²

1800 N/mm²



4
PCS

Zangen-Schale

Coquille de pinces

Assortimento di pinze
in vaschetta

Art.

4900-07B

↔ L1 402 × L2 173 × L3 48 mm



ergokraft



Art. 3281-180
DIN ISO 5746

180 mm



Art. 3282-160
DIN ISO 5749

160 mm



Art. 3285-200
DIN ISO 5745

200 mm



Art. 3289-160
DIN ISO 5232

160 mm



5
PGS

Universal-Zangen-Schale
Coquille de pinces universelles
Assortimento di pinze universali in vaschetta



Art.	
4900-57B1	4224-250
4900-57B2	4223-240
4900-57B3	4222-250

↔ L1 402 × L2 173 × L3 48 mm

4900-57B1 / Art. 4224-250

Made in Germany **HIGHTECH**

4GRIP

DIN ISO + 40%

250 mm

drag&drop

Made in Germany Art. 4276-205 205 mm
DIN ISO 5745

HIGHTECH



Art. 3292-250 max. 250/10"

CrMo



Art. 3290-230 230 mm

ergokraft

1.5 - 6 mm² 1.5 - 4.6 mm²

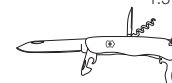

VICTORINOX

4900-57B2 / Art. 4223-240

Made in Germany

DIN ISO 8976

240 mm

Made in Germany Art. 4276-205 205 mm
DIN ISO 5745

HIGHTECH



Art. 3292-250 max. 250/10"

CrMo



Art. 3290-230 230 mm

ergokraft

1.5 - 6 mm² 1.5 - 4.6 mm²

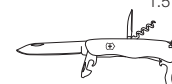

VICTORINOX

4900-57B3 / Art. 4222-250

Made in Germany

DIN ISO 8976

250 mm

Made in Germany Art. 4276-205 205 mm
DIN ISO 5745

HIGHTECH



Art. 3292-250 max. 250/10"

CrMo



Art. 3290-230 230 mm

ergokraft

1.5 - 6 mm² 1.5 - 4.6 mm²

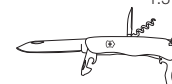

VICTORINOX



4
PCS

Universal-Zangen-Schale
Coquille de pinces universelles
Assortimento di pinze universali in vaschetta



Art.
4900-08B

↔ L1 402 × L2 173 × L3 48 mm



Art. 2221-250 250 mm
DIN ISO 8976



Art. 2216-200 200 mm
DIN ISO 9243



Art. 2262-07 7-1/2" 195 mm

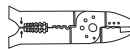
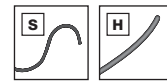

Art. 2225 240 mm 1.5 - 6 mm² 1.5 - 4.6 mm²

4
PCS

Seegerring-Zangen-Schale
Coquille de pinces pour circlips
Assortimento di pinze per anelli Seeger in vaschetta



Art.
4900-09B

↔ L1 402 × L2 173 × L3 48 mm

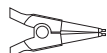

Art. 2212-A2 A2
DIN ISO 5254A

⊙ ⊙ ∅ 19-60 mm



Art. 2213-A21 A21
DIN ISO 5254B

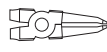

Art. 2214-J2 J2
DIN ISO 5256C

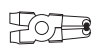

Art. 2215-J21 J21
DIN ISO 5256D

5
PGS

Rollgabelschlüssel- und Zangen-Schale

Coquille de clés à molette et pinces

Assortimento di pinze autobloccanti, chiavi a rullino e cesoia in vaschetta



ergokraft

Art.

4900-21B

↕ L1 402 × L2 173 × L3 48 mm



ergokraft

Art. 3572 150 mm / 6"

○ 0-13 mm

Art. 3573 200 mm / 8"

○ 0-25 mm

DIN 3117 / ISO 6787



ergokraft M2

Art. 2243 250 mm

HRC 58-60



Art. 3292-175 175 mm / 7"

CrMo



Art. 3292-150 150 mm / 6"

CrMo

11
PGS

Feilen-Schale

Coquille de limes

Assortimento di lime in vaschetta



ergokraft

Art.

4900-10B

↕ L1 402 × L2 173 × L3 48 mm



Art. 4320-1 320 mm

▮ ▯ ▱ ▲ △ Art. 4321



Art. 4320-2 320 mm



Art. 4320-3 320 mm



Art. 4320-4 320 mm



Art. 4320-5 320 mm

DIN 7261

DIN 7261

DIN 7261

DIN 7261

DIN 7261

COMPLETO Serie 4900 ergokraft

22
PCS

Schneidwerkzeug-Schale
Coquille d'outils de coupe
Assortimento di attrezzi da taglio in vaschetta



Art.

4900-11B

↔ L1 402 × L2 173 × L3 48 mm



ergokraft

Art. 3310

9 mm



12x

Art. 3313

9 mm



ergokraft

Art. 3312

18 mm

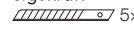

5x

Art. 3314

18 mm



Art. 3305

300 mm



ergokraft

Art. 3308-1



Art. 3316-24

300 mm

HSS-Bimetall



ergokraft

Art. 2240

11
PCS

Schlagwerkzeug-Schale
Coquille d'outils de frappe
Assortimento di attrezzi a percussione in vaschetta



Art.



4900-56B

Art. 2305

500 g

4900-66B

Art. 2319

500 g

↔ L1 402 × L2 173 × L3 48 mm

4900-56B / Art. 2305



4900-66B / Art. 2319



Art. 2336

Ø 35 mm



Art. 3380-18

18 mm

Art. 3380-22

22 mm

DIN 6451/53



Art. 1350-2

2 mm

Art. 1350-3

3 mm

Art. 1350-4

4 mm

Art. 1350-5

5 mm

Art. 1350-6

6 mm

Art. 1350-8

8 mm

DIN 6450 Form C



Art. 1358-2

No. 2

DIN 7250

9
PCS





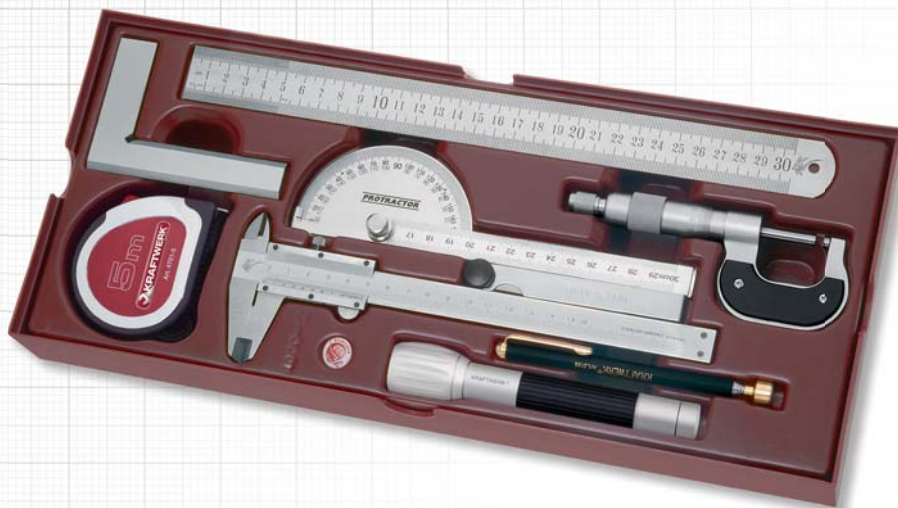

Messwerkzeug-Schale
Coquille d'outils de mesure
Assortimento di strumenti
di misura in vaschetta

Art.

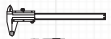
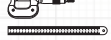
4900-12B

↔ L1 402 × L2 173 × L3 48 mm



- | | | |
|---|----------------|--|
|  | Art. 4701-0519 | 5 m × 19 mm |
|  | Art. 2970 | 150 mm × 0.05 mm 6" × 1/128" |
|  | Art. 2975 | 0-25 mm × 0.01 mm |
|  | Art. 2976 | 300 mm × 28 mm |
|  | Art. 2977 | 200 mm |
|  | Art. 2978 | 100 mm × 70 mm |
|  | Art. 2974 | 0.05-0.1-0.15-0.2-0.3-0.4-0.5-0.6-0.7-0.8 mm |
|  | Art. 3196 | 130-630 mm / 2000 g |
|  | Art. 4996 | |

HSS-G 40
PCS







Bohr- und Gewindeschneid-
werkzeug-Schale
Coquille de tarauds et filières
Assortimento di maschi,
filieri e punte in vaschetta

Art.

4900-34B

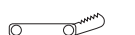
↔ L1 402 × L2 173 × L3 48 mm

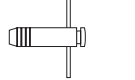

- | | | | | | |
|---|-----------------|-----------------|---|---|---------|
|  | Art. 23030 | M3 | Art. 11904
DIN 338 N | 1-1.5-2-2.5-3-3.5-4-4.5-5-5.5-6-6.5-7-7.5-8-8.5-9-9.5-10 mm | |
| | Art. 23040 | M4 | | | |
| | Art. 23050 | M5 | | | |
| | Art. 23060 | M6 | | | |
| | Art. 23080 | M8 | | | |
| | Art. 23100 | M10 | | | |
| | Art. 23120 | M12 | | | |
|  | Art. 24200 | 0.25-6 mm / 60° |  | Art. 11033 | 3.3 mm |
|  | Art. 24015 | M2-M12 |  | Art. 11042 | 4.2 mm |
| | DIN 1814 | |  | Art. 11068 | 6.8 mm |
|  | Art. 24110 | M3-M10 |  | Art. 11102 | 10.2 mm |
| | DIN 1814 | | | DIN 338 N | |
| | | |  | Art. 25030 | M3 |
| | | | | Art. 25040 | M4 |
| | | | | Art. 25050 | M5 |
| | | | | Art. 25060 | M6 |
| | | | | Art. 25080 | M8 |
| | | | | Art. 25100 | M10 |
| | | | | Art. 25120 | M12 |
| | | | | DIN 371 | |

HSS-G **42**
PCS

Bohr- und Gewinde-
schneidwerkzeug-Schale
Coquille de tarauds et filières
Assortimento di maschi,
filiere e punte in vaschetta

Art.

4900-59B

↔ L1 402 × L2 173 × L3 48 mm



Art. 26030 M3
Art. 26040 M4
Art. 26050 M5
Art. 26060 M6
Art. 26080 M8
Art. 26100 M10
Art. 26120 M12
DIN / ISO 261



Art. 24200 0.25-6 mm / 60°



Art. 24010 M3-M12
DIN 225



Art. 24015 M2-M12
DIN 1814



Art. 24110 M3-M10
DIN 1814



Art. 11904 1-1.5-2-2.5-3-3.5-4
DIN 338 N 4.5-5-5.5-6-6.6-7-7.5
8-8.5-9-9.5-10 mm



Art. 11033 3.3 mm
Art. 11042 4.2 mm
Art. 11068 6.8 mm
Art. 11102 10.2 mm
DIN 338 N



Art. 25030 M3
Art. 25040 M4
Art. 25050 M5
Art. 25060 M6
Art. 25080 M8
Art. 25100 M10
Art. 25120 M12
DIN 371



Art. 3240S Ø 0.5 mm

HSS-G **77**
PCS

Gewinde-Einsatz-
Werkzeuge-Schale
Kit de réparation de filetages,
avec filets rapportés
Assortimento di filetti
riportati in vaschetta

Art.

4900-51B

↔ L1 402 × L2 173 × L3 48 mm



M4-M12, M6-M20
3/18"-1/2", 1/4"-3/4"



M5×0.8, M6×1.0,
M8×1.25, M10×1.5,
M12×1.75, M14×1.25

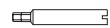

M5×0.8, M6×1.0,
M8×1.25, M10×1.5,
M12×1.75, M14×1.25



M5×0.8, M6×1.0,
M8×1.25, M10×1.5,
M12×1.75, M14×1.25



215-640 mm

0.5-1.75 mm



16 M5-0.8
12 M6-1.0
10 M8-1.25
6 M10-1.5
5 M12-1.75
4 M14-1.25



HSS
bimetal
M42+8%Co

Lochsägen-Schale
Coquille de scies trépan
Assortimento di seghe a tazza
in vaschetta

Art.		
4900-39B		✓
4900-39BS		

↔ L1 402 × L2 173 × L3 48 mm



16
PCS

15
PCS

	Art. 19001	Art. 19005	14-30 mm / 3/8"
	Art. 19002	Art. 19006	32-76 mm / 7/16"
	Art. 19003		300 mm / 3/8"
	Art. 19190	19 mm	Art. 19380 38 mm
	Art. 19200	20 mm	Art. 19440 44 mm
	Art. 19220	22 mm	Art. 19510 51 mm
	Art. 19250	25 mm	Art. 19570 57 mm
	Art. 19290	29 mm	Art. 19680 68 mm
	Art. 19320	32 mm	Art. 19760 76 mm
	Art. 19350	35 mm	

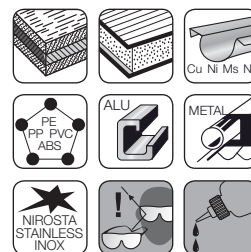

Werkstatt-LED-Lampen-Schale

Coquille de lampes LED d'atelier

Assortimento di lampade LED in vaschetta

Art.	LIGHT	Art.
4900-52B		32022 + 32001UV + 32051
4900-53B		32022 + 32001 + 32051

↔ L1 402 × L2 173 × L3 48 mm

8
PCS



LIGHT



Art. 32022
↔ 285 mm, Ø 40 mm



4900-52B / Art. 32001UV
4900-53B / Art. 32001
↔ 250 mm, Ø 36 mm



Art. 32051
↔ 145 mm, Ø 28 mm

3W COB LED
80-100 LUX
170-200 lm
* Chip On Board/sur circuit imprimé

Li-Ion 3.7 V
(4000 mAh)

4900-52B / Art. 32001UV
18 + 4 UVLED
500 LUX (1m) + 120 LUX (1m)

4900-53B / Art. 32001
18 + 4 LED
500 LUX (1m) + 120 LUX (1m)

3W GREE 1 LED
80 lm

0-200 m ZOOM



Modulare Werkstatt-LED-Lampen-Schale

- speziell starker 3 W COB-LED Lampenkopf
- extrem schmaler Lampenkopf mit 10 SMD-LED 3 W für schwer zugängliche Stellen
- Taschenlampen-LED-Kopf mit Zoom-Funktion
- Schwanenhals-LED-Lampenkopf
- 2 wiederaufladbare Auswechsel-Akkus
- Lampenhalter mit Vakuum-Saugfuss
- Ladestation mit Batterie-Ladeanzeige, USB-Ladekabel 100-240 V, Auto-/LKW-Lade-Adapter 12-24 V.

Coquille de lampes d'atelier à LED modulables

- Lampe à LED COB 3 W extrêmement puissante
- Lampe à tête extra fine avec 10 LED SMD de 3 watts pour les zones difficilement accessibles
- Lampe de poche à LED avec fonction zoom
- Lampe LED col de cygne
- 2 batteries rechargeables et interchangeables
- Support ventouse pour lampes
- Station de charge équipée d'un voyant de charge, avec câble USB, chargeur secteur 100-240V et prise allume-cigare 12-24V

Assortimento di lampade modulari LED per officina in vaschetta

- Lampada da 3 W COB-LED particolarmente potente
- Testa estremamente sottile a 10 SMD-LED 3 W per illuminare posti difficili da raggiungere
- Testa torcia LED con funzionalità zoom
- Lampada a LED a collo di cigno
- 2 batterie ricaricabili ed intercambiabili
- Base per lampada a ventosa
- Alimentatore con indicatore del livello della batteria, cavo USB 100-240 V ed adattatore per auto e camion da 12-24 V

11
PCS



Art. 4900-73B

421 x 200 x 68 mm

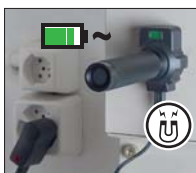

2x Li-Ion 3.7 V
(2000 mAh)

2-6.5 h 3-4 h -5°C- 40°C



1 COB LED 70-90 LUX (1m) 100-140 lm	120° IP54 L: 200 mm
10 SMD LED 100-120 LUX (1m) 270-300 lm	IP20 L: 343 mm
1 SMD LED 280-2100 LUX (1m) 80-150 lm	IP54 ZOOM L: 154 mm
1 SMD LED 300-340 LUX (1m) 80-100 lm	IP20 Flexible L: 490 mm

Art. 4900-73-01
Optional / ~~opcion~~ / Optionale

UV
Lampe
Lámpara
Lâmpada

Art.

4900-73B

Reifendruck-Kontrollsystem-Werkzeugschale

geeignet für TPMS, zur Demontage und Montage von Reifendruck-Kontrollsystemen. Optimale Bestückung für alle Typen.

Coquille d'outils pour capteur de pression de pneu

adaptés pour TPMS, pour démonter et monter les systèmes de contrôle de pression des pneus. Composition optimale pour tous les modèles.

Assortimento di utensili per il controllo della pressione dei pneumatici

per TPMS, per lo smontaggio e rimontaggio del sistema della pressione dei pneumatici. Assortimento ottimale per tutti i veicoli.

1/4"

15
PCS

COMPLETO

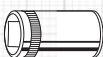

2 11-12 mm



3 T10-T15-T20
4.5 mm

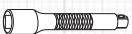

50 mm

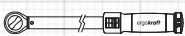

Art. 3231

2.5-12 Nm / 20-105 Lb.in



1/4" 1/4"

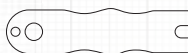

140 mm

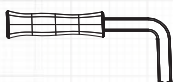

1/4" 100 mm



1/4"



1/4" 4 mm 0 Lb.in 150 mm
0.5-3.5 Nm / 4.5-30 Lb.in 150 mm



2 0.25-0.45 Nm / 2.2-4 Lb.in 120 mm



2 mm

421 x 200 x 68 mm

Art.

4900-74B

5

PCS

Klebegewichte-Zange-Schale

Coquille de pince pour masse d'équilibrage adhésive

Vaschetta con pinza per contrappesi adesivi



Art. 4257-240 240 mm



Art. 3843 225 mm



Art. 3843RE Ø 100 x 15 mm



DE



FR



IT



421 x 200 x 68 mm

Art.

4900-75B

4
PCS

Foto-/Video-Endoskop-Schale Coquille de photo-/ vidéo-endoscope

Assortimento endoscopio Foto/
Video in vaschetta

Art.	Ø mm	L	
4900-45B-0391	3.9	1 m	flex
4900-45B-0393	3.9	3 m	flex
4900-45B-0550*	5.5	1 m	mem
4900-45B-0551*	5.5	1 m	flex
4900-45B-0553*	5.5	3 m	flex
4900-45B-0800	8.0	1 m	mem
4900-45B-0801	8.0	1 m	flex
4900-45B-1200	12.0	1 m	mem

 L1 402 × L2 173 × L3 48 mm



 L1 94 × L2 78 × L3 10 mm



Display 3.5" / 89 mm TFT
640 × 480 pixel
16.7 Mio. Colors / 30 bps

Video PAL / NTSC

Sensor CMOS

Batterie Li-Polymer-Akku 3.7 V 2000 mAh
(100~240 V / 50-60 Hz)

Memory SD Card 2GB (max. 4GB)
IP67

flex = flexibel / souple / flessibile
mem = halbstarr / rigide / rigido

* Längere Kabel auf Anfrage
Des câbles plus longs sur demande
Cavi più lunghi su richiesta

inklusive / inclus / incluso:

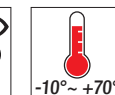
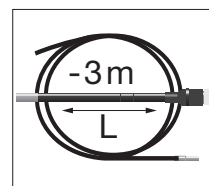
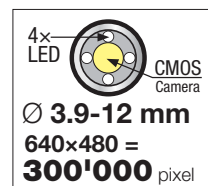
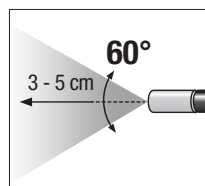

Optional / Option / Opzionali :
4900-45B-0550 / 4900-45B-0551 / 4900-45B-0553

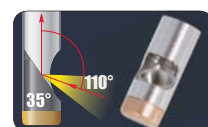

Art. 4900-45-02

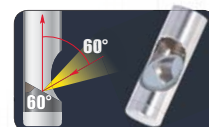

Art. 4900-45-03



Kleinteile-Schale
Coquilles pour petites pièces
Vaschetta portaminuteria

Art.

4900-37B

↕ L1 402 × L2 173 × L3 48 mm



ABS-Schale
leer
Coquille en ABS
vide
Scomparto in ABS
vuoto

Art.

4900E

↕ L1 402 × L2 173 × L3 48 mm



COMPLETO Serie 4900

ABS-Tragkoffer

für COMPLETO-Schalen, leer

Coffret en ABS

pour coquilles COMPLETO, vide

Valigetta ABS

per assortimenti COMPLETO, vuota

Art.

4900K

↔ L1 421 × L2 200 × L3 68 mm



SEL14

Werkzeugtasche

Praktisch und solid mit Tragriemen und 4 seitlichen Werkzeugfächern sowie grossem Werkzeugfach auf der Oberseite. Bietet Platz für 6 **COMPLETO**-Schalen.

Sacoche de transport

en bandoulière pratique et solide composée de quatre compartiments en façade plus un sur le dessus, pouvant accueillir 6 modules **COMPLETO**.

Valigia per utensili

Solida e pratica. Tasca anteriore esterna, una interna e due laterali. Comoda tracolla. Accoglie 6 assortimenti **COMPLETO**.

Art.
4900T

↔ L1 450 × L2 360 × L3 230 mm



Werkzeugtasche

mit 4 Leerschalen.

Sacoche de transport

avec 4 coquilles vides.

Valigia per utensili

con 4 vaschette vuote.



Art.
4900TS 4 × 4900E

↔ L1 450 × L2 360 × L3 230 mm



Video
[KRAFTWERKtools.com/video/4900T](https://www.KRAFTWERKtools.com/video/4900T)

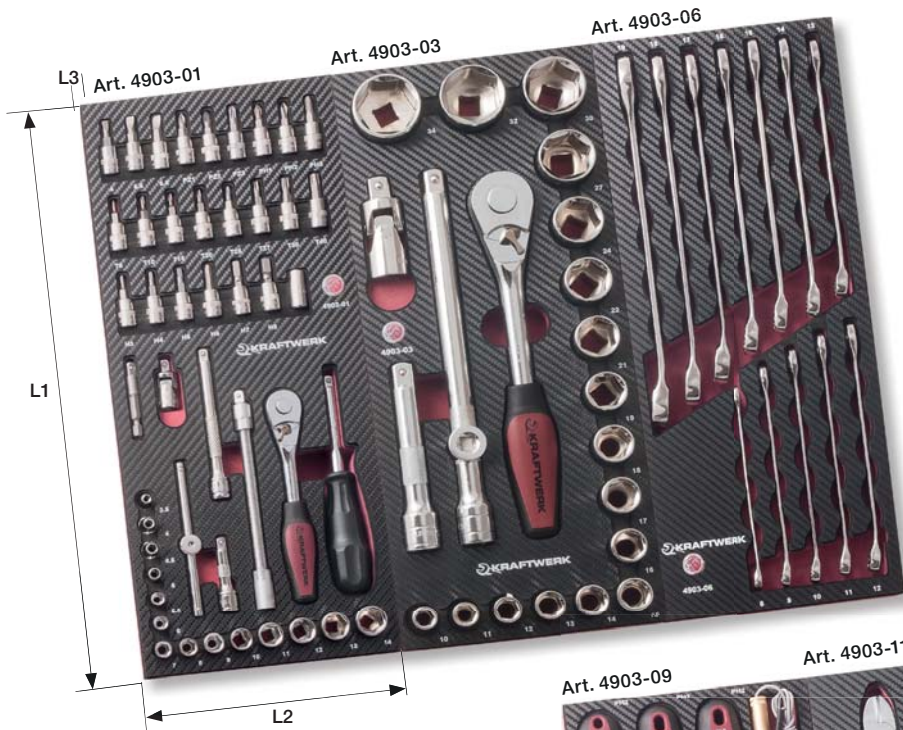

Werkzeug-Zusammenstellung

Basis-Sortiment für 2 Schubladen

Assortiment d'outils

de base pour 2 tiroirs

Assortimento di utensili

base per 2 cassetti

Art.	
4931	4903-01, 4903-03, 4903-06, 4903-09, 4903-11, 4903-13

↕ L1 394 × L2 168 × L3 30 mm

Werkzeug-Zusammenstellung

mit Werkstattwagen

Assortiment d'outils

avec servantes

Assortimento di utensili

con carrelli

	Art.
1	3907-4931
2	3908-4931
3	3909-4931
4	3905-4931
5	3934-4931
6	2905-4931
7	2907-4931
8	2904-4931





Steckschlüssel-Einlage

Module de douilles

Assortimento di chiavi a bussola
in vassoio

Art.
4903-01

↔ 394 x 168 x 30 mm

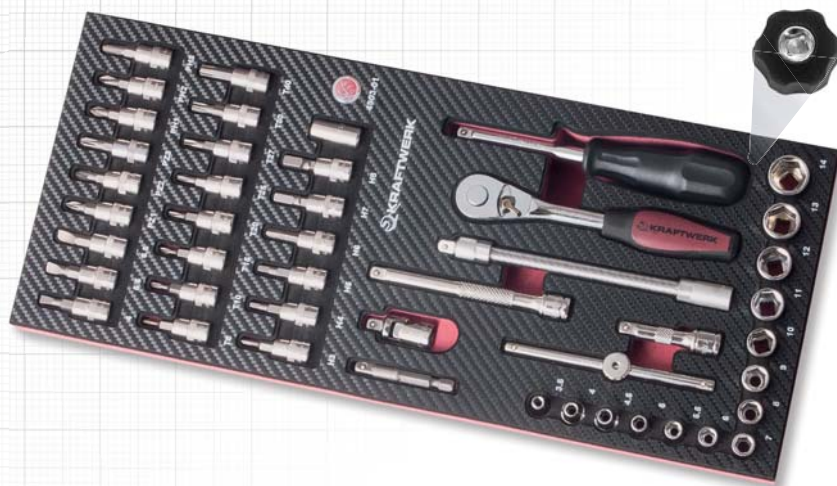

- | | | | | | |
|--|----|---|--|-----------|----------------|
| | 14 | 3.5-4-4.5-5-5.5-6-7-8-9-10-11-12-13-14 mm | | 2 | 50 mm / 100 mm |
| | 3 | 4-5.5-6.5 mm | | | 150 mm |
| | 3 | PH 1-2-3 | | | 115 mm |
| | 3 | PZ 1-2-3 | | | □ 1/4" ■ 1/4" |
| | 8 | T8-T10-T15-T20-T25-T27-T30-T40 | | | ● 1/4" ■ 1/4" |
| | 6 | 3-4-5-6-7-8 mm | | | |
| | | ○ 1/4" ○ 1/4" | | | |
| | | ○ 1/4" ■ 1/4" | | | |
| | | | | Art. 3200 | |



Steckschlüssel-Einlage

Module de douilles

Assortimento di chiavi a bussola
in vassoio

Art.
4903-02

↔ 394 x 168 x 30 mm



- | | | |
|--|----|---|
| | 15 | 8-9-10-11-12-13-14-15-16-17-18-19-21-22-24 mm |
| | 8 | 10-11-12-13-14-15-17-19 mm |
| | 2 | 16 mm / 21 mm |
| | | ○ 3/8" ■ 3/8" |
| | 2 | 75 mm / 250 mm |
| | | ○ 1/2" ■ 3/8" |
| | | ○ 3/8" ■ 1/4" |
| | | ● 1/4" ■ 3/8" |

Art. 3210











Steckschlüssel-Einlage
Module de douilles
Assortimento di chiavi a bussola in vassoio

Art.
4903-03

↕ 394 x 168 x 30 mm



-  17 10-11-12-13-14-15-16-17-18
19-21-22-24-27-30-32-34 mm
-   2 1/2" ■ 1/2"
-  2 125 mm / 250 mm
-   3/8" ■ 1/2"
-  (45)  Art. 3220







Bit-Stecknuss-Einlage
Module de douilles-embouts
Assortimento di bussole giravite in vassoio

Art.
4903-04

↕ 394 x 168 x 30 mm



-  S2 5 ● 5-6-7-8-10 mm
-  S2 5 ● M5-M6-M8-M10-M12
-  S2 5 ● 6-7-8-10-12 mm
-  S2 4 ● M5-M6-M8-M10

1/2" **S2** quality **19** PCS

Steckschlüssel- und Bit-Stecknuss-Einlage

Module de douilles et douilles-embouts







Assortimento di bussole e bussole giravite in vassoio

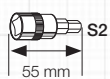

Art.

4903-05

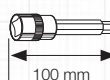
↔ 394 x 168 x 30 mm

-  8  E10-E12-E14-E16-E18-E20-E22-E24
-  S2 6  T30-T40-T45-T50-T55-T60
-  S2 5  T30-T40-T45-T50-T55

12 PCS

Gabelringschlüssel-Einlage

Module de clés combinées

Assortimento di chiavi combinate in vassoio



Art.

4903-06

↔ 394 x 168 x 30 mm

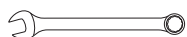
-  **DIN 3113**
- Art. 3508 8 mm
- Art. 3509 9 mm
- Art. 3510 10 mm
- Art. 3511 11 mm
- Art. 3512 12 mm
- Art. 3513 13 mm
- Art. 3514 14 mm
- Art. 3515 15 mm
- Art. 3516 16 mm
- Art. 3517 17 mm
- Art. 3518 18 mm
- Art. 3519 19 mm

8
PCS

Gabelringschlüssel-Einlage
Module de clés combinées
Assortimento di chiavi combinate
in vassoio

Art.

4903-07

↕ 394 x 168 x 30 mm

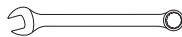

DIN 3113

Art. 3505	5.5 mm
Art. 3506	6 mm
Art. 3507	7 mm
Art. 3520	20 mm
Art. 3521	21 mm
Art. 3522	22 mm
Art. 3523	23 mm
Art. 3524	24 mm

8
PCS

Doppelringschlüssel-Einlage
Module de clés polygonales
Assortimento di chiavi
poligonal doppie in vassoio

Art.

4903-08

↕ 394 x 168 x 30 mm



DIN 838

Art. 3480	6 x 7 mm	Art. 3484	14 x 15 mm
Art. 3481	8 x 9 mm	Art. 3485	16 x 17 mm
Art. 3482	10 x 11 mm	Art. 3486	18 x 19 mm
Art. 3483	12 x 13 mm	Art. 3487	20 x 22 mm

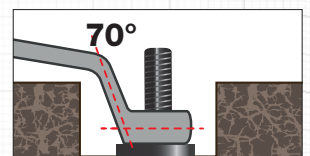

12
PCS



Gabelringschlüssel-Einlage
Module de clés combinées
Assortimento di chiavi combinate
in vassoio

Art.
4903-16

↕ 394 x 168 x 30 mm



COMBINATION
CLICKRAFT

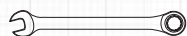

DIN 3113

Art. 3408	8 mm
Art. 3409	9 mm
Art. 3410	10 mm
Art. 3411	11 mm
Art. 3412	12 mm
Art. 3413	13 mm
Art. 3414	14 mm
Art. 3415	15 mm
Art. 3416	16 mm
Art. 3417	17 mm
Art. 3418	18 mm
Art. 3419	19 mm

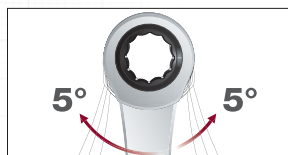

12
PCS



Doppel-Ratschen-Ringgabel-
schlüssel-Einlage
Module de clés combinées à
cliquet double
Assortimento di chiavi combinate
a doppio cricchetto

Art.
4903-17

↕ 394 x 168 x 30 mm



COMBINATION *plus*
DOUBLE RATCHET
CLICKRAFT

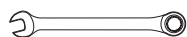

DIN 3113

Art. 3401-08	8 mm
Art. 3401-09	9 mm
Art. 3401-10	10 mm
Art. 3401-11	11 mm
Art. 3401-12	12 mm
Art. 3401-13	13 mm
Art. 3401-14	14 mm
Art. 3401-15	15 mm
Art. 3401-16	16 mm
Art. 3401-17	17 mm
Art. 3401-18	18 mm
Art. 3401-19	19 mm

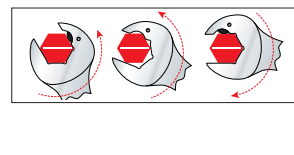
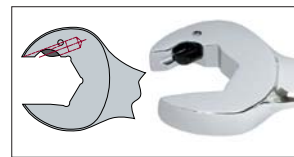
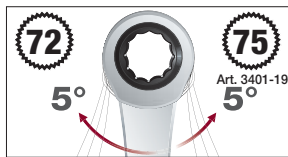

12
PCS



Umschaltbare Ratschen-Ring-
gabelschlüssel-Einlage
*Module de clés combinées à
cliquet réversible*
Assortimento di chiavi combinate
a cricchetto reversibili

Art.

4903-18

↕ 394 x 168 x 30 mm

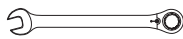

DIN 3113

Art. 3404-08	8 mm
Art. 3404-09	9 mm
Art. 3404-10	10 mm
Art. 3404-11	11 mm
Art. 3404-12	12 mm
Art. 3404-13	13 mm
Art. 3404-14	14 mm
Art. 3404-15	15 mm
Art. 3404-16	16 mm
Art. 3404-17	17 mm
Art. 3404-18	18 mm
Art. 3404-19	19 mm

CAP STOP

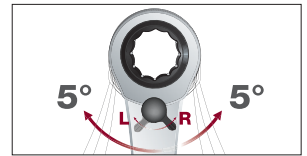

13
PCS

Pfeifenkopfschlüssel-Schalen
*Coquilles de clés à pipe
débouchées*
Assortimenti di chiavi a pipa in
vaschetta

Art.

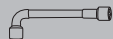

4903-29



↕ 394 x 168 x 30 mm

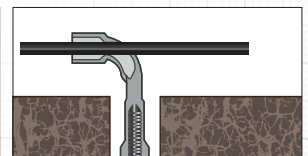
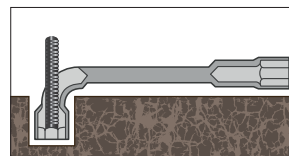

Art. 2597-07	7 mm
Art. 2597-08	8 mm
Art. 2597-09	9 mm
Art. 2597-10	10 mm
Art. 2597-11	11 mm
Art. 2597-12	12 mm
Art. 2597-13	13 mm



Art. 2597-14	14 mm
Art. 2597-15	15 mm
Art. 2597-16	16 mm
Art. 2597-17	17 mm
Art. 2597-18	18 mm
Art. 2597-19	19 mm

4
PGS

Pfeifenkopfschlüssel-Schalen

Coquilles de clés à pipe débouchées

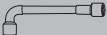
Assortimenti di chiavi a pipa in vaschetta

Art.	
4903-30	

↕ 394 x 168 x 30 mm

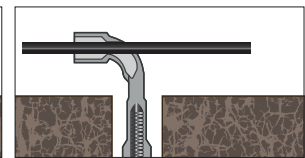
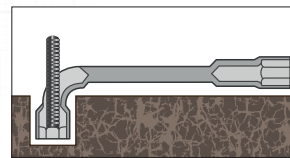



- Art. 2597-20 20 mm
- Art. 2597-21 21 mm
- Art. 2597-22 22 mm
- Art. 2597-24 24 mm

3
PGS

Pfeifenkopfschlüssel-Schalen

Coquilles de clés à pipe débouchées

Assortimenti di chiavi a pipa in vaschetta

Art.	
4903-31	

↕ 394 x 168 x 30 mm

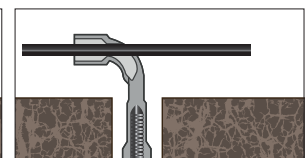
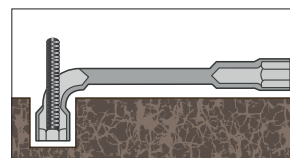

- Art. 2597-27 27 mm
- Art. 2597-30 30 mm
- Art. 2597-32 32 mm

ergokraft

S2
quality

9
PCS

Schraubendreher-Einlage
Module de tournevis
Assortimento di giraviti in
vassoio



Art.

4903-09

↕ 394 x 168 x 30 mm

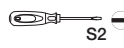

Art. 4110-2 0.8 x 4 mm
Art. 4110-3 1.0 x 5 mm
Art. 4110-4 1.1 x 6 mm
Art. 4110-5 1.2 x 8 mm



Art. 4112-2 1.1 x 6 mm



Art. 4117-2 PH 2

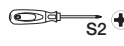

Art. 4115-1 PH 1
Art. 4115-2 PH 2



Art. 2139 12 V

S2
quality

8
PCS

Schraubendreher-Einlage
Module de tournevis
Assortimento di giraviti in
vassoio

ergokraft



Art.

4903-10

↕ 394 x 168 x 30 mm



Art. 4125-08 T8
Art. 4125-10 T10
Art. 4125-15 T15
Art. 4125-20 T20
Art. 4125-25 T25
Art. 4125-27 T27
Art. 4125-30 T30
Art. 4125-40 T40

S2 quality **8** PCS

ergokraft

Schlagkappen-Schraubendreher-Einlage
Module de tournevis de frappe
Assortimento di giraviti martellabili



Art.
4903-19

↔ 394 x 168 x 30 mm



Art.	Size	Length	Tip Width
Art. 4140-3	5.5 x 100 mm	5.5 mm	
Art. 4140-4	6.5 x 125 mm	6.5 mm	
Art. 4140-5	8.0 x 150 mm	8.0 mm	
Art. 4140-6	10.0 x 175 mm	10.0 mm	

Art.	Tip	Length	Tip Width
Art. 4145-1	PH1	75 mm	5.0 mm
Art. 4145-2	PH2	100 mm	6.0 mm

Art.	Tip	Length	Tip Width
Art. 4150-1	PZ1	75 mm	5.0 mm
Art. 4150-2	PZ2	100 mm	6.0 mm

DIN 5260-PH
ISO 8764-PH

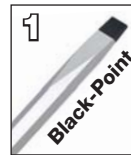

1/4" 1/4" **16** PCS

Schraubendreher-Einlage
PB Swissgrip
Module de tournevis
PB Swissgrip
Assortimento di giraviti
PB Swissgrip



Art.
4903-20

↔ 394 x 168 x 30 mm

Art. PB 8100 5	1.2 x 8 mm
Art. PB 8100 4-140	1.0 x 6.5 mm
Art. PB 8100 3-120	0.8 x 5.5 mm
Art. PB 8100 2-100	0.6 x 4.0 mm
Art. PB 8100 1- 90	0.5 x 3.5 mm

Art. PB 8190 1- 80	PH1 x 80
Art. PB 8190 2-100	PH2 x 100/6

Art. PB 8451	10 x 30 mm
--------------	------------

Art. PB 1750	110-250 V
--------------	-----------

PB SWISS TOOLS



1/4" S2 T10-T15-T20-T25-T27-T30-T40

S2 quality **29** PCS

Winkelstiftschlüssel-Einlage
 Module de clés coudées
 Assortimento di chiavi maschi esagonali





Art.
4903-27

↕ 394 x 168 x 30 mm

 **DIN 2936** S2  Art. 3604
 1,5-2-2,5-3-4-5-6-7-8-10 mm

 **XXL** S2  Art. 3608
 T10-T15-T20-T25-T27
 T30-T40-T45-T50

 **XXL** S2  Art. 3609
 T10-T15-T20-T25-T27
 T30-T40-T45-T50

 **ergokraft** Art. 3574 250 mm / 10"  0-30 mm
DIN 3117 / ISO 6787

S2 quality **7** PCS

Kugelkopf-T-Griff-Schraubendreher-Einlage
 Module de tournevis mâles à tête sphérique en T
 Assortimento di chiavi esagonali a T con testa a sfera



Art.
4903-21

↕ 394 x 168 x 30 mm

 S2 Art. 3636-3 T3
 Art. 3636-4 T4
 Art. 3636-5 T5
 Art. 3636-6 T6
 Art. 3636-7 T7
 Art. 3636-8 T8
 Art. 3636-10 T10

S2
quality

7
PCS

TX-T-Griff-Schraubendreher-
Einlage
Module de tournevis TX en T
Assortimento di chiavi TX a T



ergokraft

Art.
4903-22

↔ 394 x 168 x 30 mm

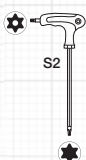

Art. 3637-10	T10
Art. 3637-15	T15
Art. 3637-20	T20
Art. 3637-25	T25
Art. 3637-27	T27
Art. 3637-30	T30
Art. 3637-40	T40

4
PCS

Hightech-Zangen-Satz
Module de pinces hightech
Assortimento di pinze hightech



HIGHTECH

Art.
4903-15

↔ 394 x 168 x 30 mm

Made in Germany



Art. 4271-180
DIN ISO 5746

180 mm **K C H**



Art. 4272-160
DIN ISO 5749

160 mm **K C H**



Art. 4275-205
DIN ISO 5745

205 mm **C H**



Art. 4223-240
DIN ISO 8976

240 mm



220 N/mm² 1800 N/mm²



4
PCS

Zangen-Einlage
Module de pinces
Assortimento di pinze in
vassoio



Art.

4903-11

↕ 394 x 168 x 30 mm



Art. 3281-180 180 mm
DIN ISO 5746



Art. 3282-160 160 mm
DIN ISO 5749



Art. 3285-200 200 mm
DIN ISO 5745



Art. 3290-250 250 mm
DIN ISO 8976

4
PCS

Gripzangen-/Bleischere-
Einlage
Module de pinces-étaux
Assortimento di pinze a
morsetto/cesoia



Art.

4903-25

↕ 394 x 168 x 30 mm



Art. 2243 250 mm HRC 58-60



Art. 3292-175 175 mm / 7" CMbd



Art. 3292-250 250 mm / 10" CMbd



Art. 3292-150 150 mm / 6" CMbd

4
PGS

Gripzangen-/Blehschere-
Einlage

Module de pinces-étaux

Assortimento di pinze a
morsetto/cesoia



ergokraft

Art.

4903-26

↔ 394 x 168 x 30 mm



M2



Art. 2243 250 mm HRC 58-60

Art. 3292-175 175 mm / 7" CMbd

Art. 3292-251 250 mm / 10" CMbd

Art. 3292-150 150 mm / 6" CMbd

4
PGS

Zangen-/Schere-Einlage

Module de pinces/cisaille

Assortimento di pinze/forbice



ergokraft

Art.

4903-28

↔ 394 x 168 x 30 mm

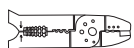

Art. 3289-160C 160 mm
DIN ISO 5232

Art. 2216-200C 200 mm
DIN ISO 9343

Art. 3290-230C

Art. 2240C 150 mm

4
PCS

Seegerring-Zangen-Einlage
Module de pinces pour circlips
Assortimento di pinze per anelli Seeger in vassoio



Art.

4903-12

↕ 394 x 168 x 30 mm

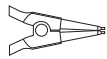

Art. 2212-A2
DIN ISO 5254A



Ø 19-60 mm



Art. 2213-A21
DIN ISO 5254B



Art. 2214-J2
DIN ISO 5256C



Art. 2215-J21
DIN ISO 5256D



18
PCS

Schneidwerkzeug-Einlage
Module d'outils de coupe
Assortimento di attrezzi da taglio



ergokraft

Art.

4903-23

↕ 394 x 168 x 30 mm



ergokraft

Art. 3310 9 mm



Art. 3313 9 mm



ergokraft

Art. 3312 18 mm

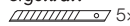

Art. 3314 18 mm



Art. 3305 300 mm

11
PGS

Feilen-Einlage
Module de limes
Assortimento di lime

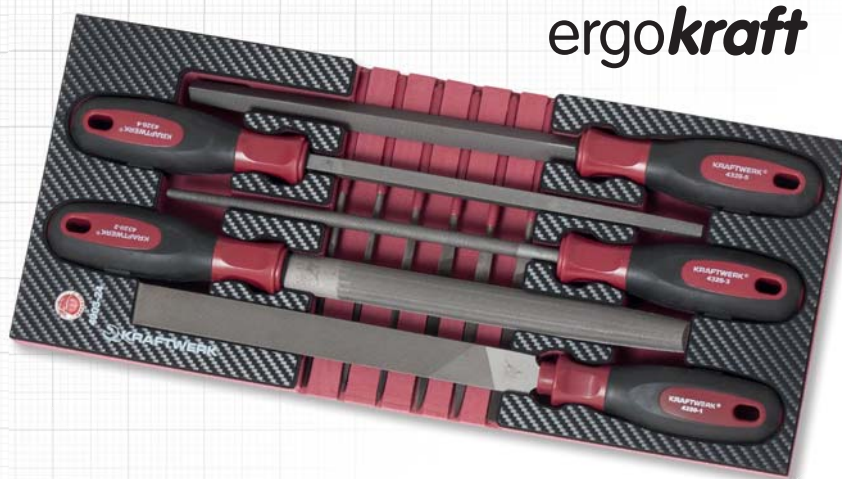





ergokraft

Art.

4903-24

↔ 394 x 168 x 30 mm

-  Art. 4320-1 320 mm
DIN 7261
-  Art. 4320-2 320 mm
DIN 7261
-  Art. 4320-3 320 mm
DIN 7261
-  Art. 4320-4 320 mm
DIN 7261
-  Art. 4320-5 320 mm
DIN 7261

▮▮▮▮▮ Art. 4321

11
PGS



Schlagwerkzeug-Einlage
Module d'outils de frappe
Assortimento di attrezzi
a percussione in vassoio



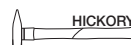
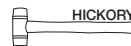

Art.

4903-13

↔ 394 x 168 x 30 mm

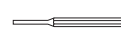
-  **HICKORY** Art. 2305 500 g
DIN 1041
-  **HICKORY** Art. 2336 Ø 35 mm
-  Art. 3380-18 18 mm
Art. 3380-22 22 mm
DIN 6451/53

-  Art. 1350-2 2 mm x 115 mm
Art. 1350-3 3 mm x 125 mm
Art. 1350-4 4 mm x 150 mm
Art. 1350-5 5 mm x 165 mm
Art. 1350-6 6 mm x 180 mm
Art. 1350-8 8 mm x 180 mm
DIN 6450 Form C
-  Art. 1358-2 No. 2 x 120 mm
DIN 7250



Schlagschrauber-Einlage
 Module de clé à choc
 pneumatique
 Assortimento con avvitatore
 a percussione



Art.		
4903-33	1/2"	3833
4903-34	1/2"	3834

↕ 394 x 168 x 30 mm

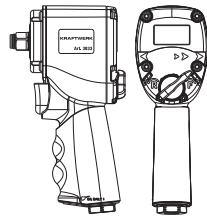

Art. 3833

1/2"	1149	920	678	9500	1500	<9.0	100.2
1.65	97	1/4"	3/8"	133	BSP	6.2	

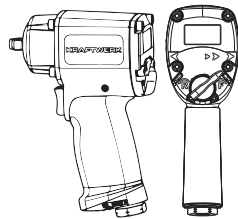

Art. 3834

1/2"	744	140-680	9000	1200	<3.6	90
1.6	125	1/4"	10	164	BSP	6.2-7



- Art. 381170-0 17 mm
- Art. 381190-0 19 mm
- Art. 381210-0 21 mm
- Art. 381220-0 22 mm
- Art. 381240-0 24 mm



- Art. 387125 125 mm

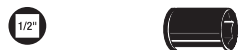

- Art. 382100 10 mm
- Art. 382120 12 mm
- Art. 382130 13 mm
- Art. 382140 14 mm
- Art. 382150 15 mm
- Art. 382170 17 mm
- Art. 382190 19 mm
- Art. 382210 21 mm
- Art. 382220 22 mm
- Art. 382240 24 mm



Art. 4902-01



Art. 4902-03



Art. 4902-02

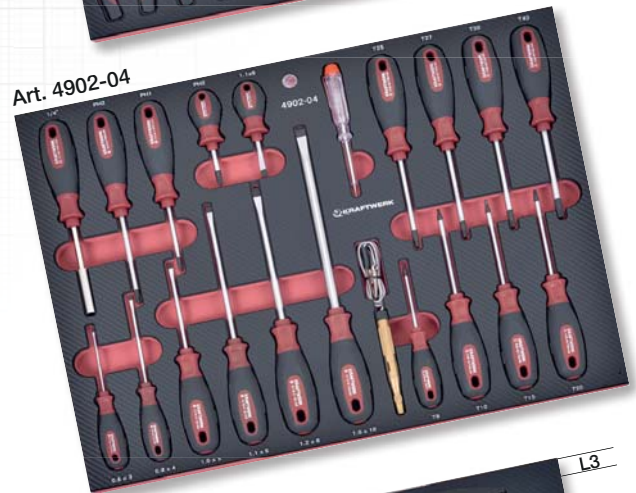

Art. 4902-04



Art. 4902-05

309
PCS



Werkzeug-Zusammenstellung

mit professionellen Werkzeugen, schüttelfest eingebettet in 6 Schubladen in speziell hochverdichteten Weich-Schaumstoff-Einlagen (EVA) mit einer dauerhaften Hartplastik-Oberschicht, die gereinigt werden kann.

Sélection d'outils professionnels

répartis dans 6 tiroirs garnis de nos inserts mousse (EVA) de haute densité avec revêtement renforcé garantissant ainsi une durée de vie plus longue et un nettoyage aisé.

Set utensili professionali

riposti in 6 esclusivi vassoi "anti-rovesciamento" realizzati in materiale espanso ad alta densità (EVA). Il top di questi vassoi è in laminato e ciò garantisce una maggior durata e una pulizia più facile.

Art.

4917

HIGHTECH / KRAFTWERK RACING

↔ L1 527 × L2 407 × L3 30 mm



Video

[KRAFTWERKtools.com/video/4917](https://www.kraftwerktools.com/video/4917)



309
PCS

Werkzeug-Zusammenstellung
mit Werkstattwagen

Assortiment d'outils
avec servantes

Assortimento di utensili
con carrelli



3910



3907



3908



3909



2907



3934



3935

Art.		
3907-4917	3907	6
3908-4917	3908	8
3909-4917	3909	11
3910-4917	3908	8
3934-4917	3934	7
3935-4917	3935	8
2907-4917	2907	7



Steckschlüssel-Satz
Jeu de douilles
Assortimento di chiavi
e bussole

Art.
4902-01

↔ L1 527 × L2 407 × L3 30 mm



- | | | | | | | | |
|--|--|----|--|--|--|------|--|
| | | 14 | 3.5-4-4.5-5-5.5-6-7-8
9-10-11-12-13-14 mm | | | 17 | 10-11-12-13-14-15-16-17-18
19-21-22-24-27-30-32-34 mm |
| | | 12 | 4-4.5-5-5.5-6-7-8-9
10-11-12-13 mm | | | 9 | 10-13-14-15-16-17-18
19-22 mm |
| | | 3 | 4-5.5-6.5 mm | | | 2 | 16 mm / 21 mm |
| | | 3 | PH 1-2-3 | | | | □ 1/2" ■ 1/2" |
| | | 3 | PZ 1-2-3 | | | 2 | 125 mm / 250 mm |
| | | 8 | T8-T10-T15-T20
T25-T27-T30-T40 | | | | □ 3/8" ■ 1/2" |
| | | 6 | 3-4-5-6-7-8 mm | | | | □ 1/2" ○ 5/16" |
| | | | ○ 1/4" ○ 1/4" | | | (60) | Art. 4020B |
| | | | □ 1/4" ■ 1/4" | | | | |
| | | 2 | 50 mm / 100 mm | | | | |
| | | | 150 mm | | | | |
| | | | 105 mm | | | | |
| | | | ○ 1/4" ■ 1/4" | | | | |
| | | | ■ 1/4" ■ 1/4" | | | | |

- 95 mm (72) Art. 3799
- (60) Art. 4000B

- | | | | |
|--|--|---|------------------------------------|
| | | 6 | 4-4.5-5.5-6-6.5-8 mm |
| | | 4 | PH 1-2-3-4 |
| | | 4 | PZ 1-2-3-4 |
| | | 8 | T8-T10-T15-T20-T25-T27-T30-T40 |
| | | 8 | T8-T10-T15-T20-T25-T27-T30-T40 |
| | | 6 | 3-4-5-6-7-8 mm |
| | | 6 | 2-2.5-3-4-5-6 mm |
| | | 6 | 5/64"-3/32"-7/64"-1/8"-9/64"-5/32" |
| | | 3 | Nos. 6-8-10 |
| | | 4 | Nos. 1-2-3-4 |
| | | 4 | Nos. 4-6-8-10 |

1/4" 1/4" 1/4" 1/4"



GLOBALBIT-Box
Art. 3777
101 × 90 × 32 mm

61
PCS

45
PCS

Schraubenschlüssel- und Drehmomentschlüssel-Satz

Jeu de clés avec clé dynamométrique

Assortimento di chiavi e chiave dinamometrica

Art.
4902-02

↕ L1 527 × L2 407 × L3 30 mm



Art. 3235 C 1/2" 40-200 Nm / 30-150 Lb.ft

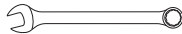
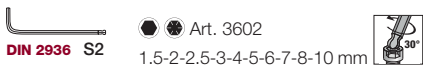

DIN 3113

Art. 3505	5.5 mm	Art. 3511	11 mm	Art. 3517	17 mm	Art. 3523	23 mm
Art. 3506	6 mm	Art. 3512	12 mm	Art. 3518	18 mm	Art. 3524	24 mm
Art. 3507	7 mm	Art. 3513	13 mm	Art. 3519	19 mm	Art. 3527	27 mm
Art. 3508	8 mm	Art. 3514	14 mm	Art. 3520	20 mm	Art. 3530	30 mm
Art. 3509	9 mm	Art. 3515	15 mm	Art. 3521	21 mm	Art. 3532	32 mm
Art. 3510	10 mm	Art. 3516	16 mm	Art. 3522	22 mm		

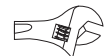

ergokraft

DIN 3117 / ISO 6787
Art. 3572 150 mm / 6"
Art. 3573 200 mm / 8"

13
PCS

Zangen-Satz

Jeu de pinces

Assortimento di pinze

Art.
4902-03

↕ L1 527 × L2 407 × L3 30 mm

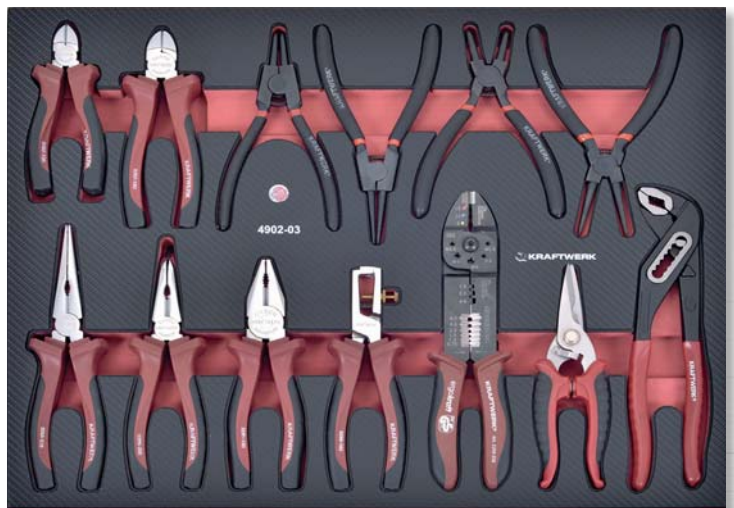

Art. 2212-A2 A2
DIN ISO 5254A



Art. 2213-A21 A21
DIN ISO 5254B



Ø 19-60 mm



Art. 2214-J2 J2
DIN ISO 5256C



Art. 2215-J21 J21
DIN ISO 5256D

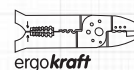

Art. 3290-230 230 mm
1.5 - 6 mm² 1.5 - 4-6 mm²

S2
quality

21
PCS









Schraubendreher-Satz
Jeu de tournevis
Assortimento di giraviti

Art.
4902-04

↔ L1 527 × L2 407 × L3 30 mm

ergokraft



- | | | | | | |
|--|-------------------------|---|------------------|---|---------------------|
|  S2 | Art. 4110-1 0.6 × 3 mm |  S2 | Art. 4117-2 PH2 |  | Art. 2138 100-250 V |
| | Art. 4110-2 0.8 × 4 mm |  S2 | Art. 4125-08 T8 |  | Art. 2139 12 V |
| | Art. 4110-3 1.0 × 5 mm | | Art. 4125-10 T10 | | |
| | Art. 4110-4 1.1 × 6 mm | | Art. 4125-15 T15 | | |
| | Art. 4110-5 1.2 × 8 mm | | Art. 4125-20 T20 | | |
| | Art. 4110-6 1.6 × 10 mm | | Art. 4125-25 T25 | | |
|  S2 | Art. 4115-1 PH1 | | Art. 4125-27 T27 | | |
| | Art. 4115-2 PH2 | | Art. 4125-30 T30 | | |
| | | | Art. 4125-40 T40 | | |
|  S2 | Art. 4112-2 1.1 × 6 mm |  | Art. 4128 1/4" | | |

41
PCS











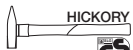



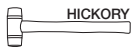

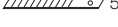



Schlag-/Schneid- und
Messwerkzeug-Satz
*Jeu d'outils de frappe,
de coupe et de mesure*
Assortimento di martelli,
punzoni, scalpelli, cutter e metro

Art.
4902-05

↔ L1 527 × L2 407 × L3 30 mm

ergokraft



- | | | | | | |
|--|-------------|---------|--|---|--|
|  HICKORY
DIN 1041 | Art. 2303 | 300 g |  Art. 1355-2 2 mm |  Art. 3196 130-630 mm |  Art. 3312 18 mm |
|  HICKORY | Art. 2336 | Ø 35 mm |  DIN 6458 |  Art. 4996 |  Art. 3314 5x 18 mm |
|  DIN 6450 Form C | Art. 1350-2 | 2 mm |  Art. 1358-1 No. 1 |  Art. 2976 |  Art. 2972 150 mm × 0.01 mm |
| | Art. 1350-3 | 3 mm |  Art. 1358-2 No. 2 |  Art. 3310 9 mm |  DIGITAL 6" × 0.0005" |
| | Art. 1350-4 | 4 mm |  Art. 3380-18 18 mm |  Art. 3313 9 mm |  |
| | Art. 1350-5 | 5 mm |  Art. 3380-22 22 mm |  12x |  Art. 4700-0316 3 m × 16 mm |
| | Art. 1350-6 | 6 mm | | | |
| | Art. 1350-8 | 8 mm | | | |

35
PCS











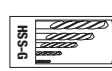

Feilen-/Sägen- und
Bohrer-Satz
*Jeu de limes, de scies
et de forets*
Assortimento di lime,
seghetti e punte

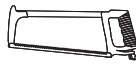
Art.

4902-06

↕ L1 527 × L2 407 × L3 30 mm

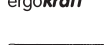

 Art. 4320-1 320 mm DIN 7261	 Art. 4321	 Art. 11904 1-1.5-2-2.5-3 DIN 338 N 3.5-4-4.5-5-5.5 6-6.5-7-7.5-8 8.5-9-9.5-10 mm
 Art. 4320-2 320 mm DIN 7261	 Art. 3305 300 mm	 Art. 5433 3-30 mm CU
 Art. 4320-3 320 mm DIN 7261	 Art. 3308-1	 Art. 5470 Ø 4-40 cm
 Art. 4320-4 320 mm DIN 7261	 Art. 3316-24 300 mm	
 Art. 4320-5 320 mm DIN 7261	 HSS-Bimetall	

12
PCS



T-Griff-Gelenkschlüssel-Satz
extra lang
*Jeu de clés articulées en T
extra longues*
Assortimento di chiavi
esagonali snodate a T
extra lunghi

Art.

4902-07

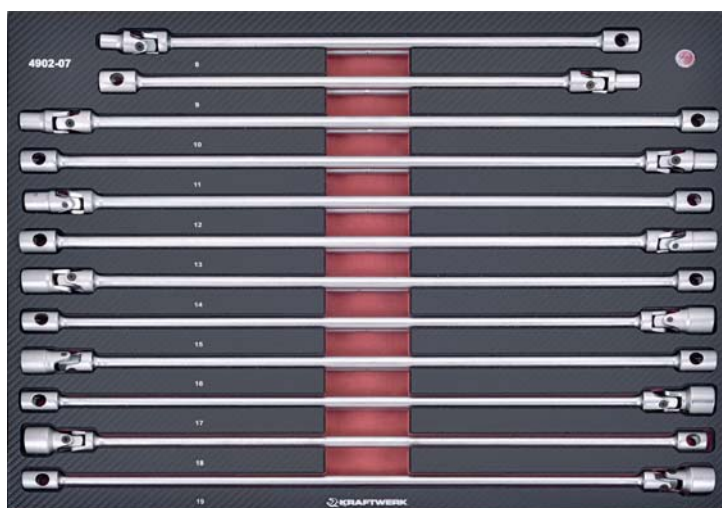
↕ L1 527 × L2 407 × L3 30 mm



	XXL	DIN 896 / ISO 2236, 1085	
Art. 2592-08 8 mm	Art. 2592-14 14 mm		
Art. 2592-09 9 mm	Art. 2592-15 15 mm		
Art. 2592-10 10 mm	Art. 2592-16 16 mm		
Art. 2592-11 11 mm	Art. 2592-17 17 mm		
Art. 2592-12 12 mm	Art. 2592-18 18 mm		
Art. 2592-13 13 mm	Art. 2592-19 19 mm		



21
PCS

Steckschlüsselsatz für den Schwersteinsatz

mit Feinzahn-Umschaltknarre mit Stecknuss-Auswurf-Mechanismus. Verlängerungen mit Verriegelungs-System.

Jeu de douilles pour poids lourds

avec cliquet à denture fine avec mécanisme d'éjection de douilles et rallonges avec système de verrouillage.

Assortimento di chiavi a bussola per impieghi pesanti

con chiave a cricchetto a denti fini con meccanismo di sgancio rapido e sistema di bloccaggio.

Art.

4902-08

↔ L1 527 × L2 407 × L3 40 mm



16 19-21-22-23-24-26-27-29-30
32-35-36-38-41-46-50 mm

3 100-200-400 mm

460 mm



22
PCS

Steckschlüsselsatz für den Schwersteinsatz

mit Digital-Drehmoment-Adapter

Jeu de douilles pour poids lourds

avec adaptateur dynamométrique digital

Assortimento di chiavi a bussola per impieghi pesanti

con adattore dinamometrico digitale

Art.



4902-080

4081-34

4902-081

4081-341

↔ L1 527 × L2 407 × L3 40 mm



16 19-21-22-23-24-26-27-29-30
32-35-36-38-41-46-50 mm

3 100-200-400 mm

460 mm

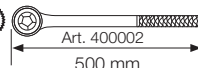

4902-080 / Art. 4081-34

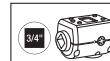

Art. **4081-34**
100-500 Nm (± 2%) / 73.8-369 Lb.ft
kg-m / kg-cm / lb-in / ft-lbs

4902-081 / Art. 4081-341

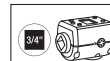

Art. **4081-341**
200-1000 Nm (± 2%) / 147.6-738 Lb.ft
kg-m / kg-cm / lb-in / ft-lbs





Steckschlüsselsatz für den Schwersteinsatz

mit fein verzahnter **Teleskop**-Auszug-Umschaltknarre mit Stecknuss-Auswurf-Mechanismus. Verlängerungen mit Verriegelungs-System

Jeu de douilles pour poids lourds

avec cliquet à denture fine avec manche **télescopique** et mécanisme d'éjection de douilles. Rallonges avec système de verrouillage

Assortimento di chiavi a bussola per impieghi pesanti

con chiave a cricchetto **estensibile** a denti fini con meccanismo di sgancio rapido e sistema di bloccaggio

Art.
4902-09

↕ L1 527 × L2 407 × L3 40 mm

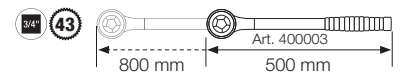

- 16 19-21-22-23-24-26-27-29-30
32-35-36-38-41-46-50 mm
- 3 100-200-400 mm
- 460 mm



Steckschlüsselsatz für den Schwersteinsatz

mit Digital-Drehmoment-Adapter

Jeu de douilles pour poids lourds

avec adaptateur dynamométrique digital

Assortimento di chiavi a bussola per impieghi pesanti

con adattore dinamometrico digitale

Art.	
4902-090	4081-34
4902-091	4081-341

↕ L1 527 × L2 407 × L3 40 mm



- 16 19-21-22-23-24-26-27-29-30
32-35-36-38-41-46-50 mm

- 3 100-200-400 mm
- 460 mm

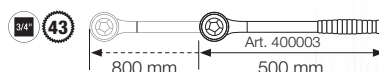

4902-090 / Art. 4081-34

Art. 4081-34
 100-500 Nm (± 2%) / 73.8-369 Lb.ft
 kg-m / kg-cm / lb-in / ft-lbs

4902-091 / Art. 4081-341

Art. 4081-341
 200-1000 Nm (± 2%) / 147.6-738 Lb.ft
 kg-m / kg-cm / lb-in / ft-lbs

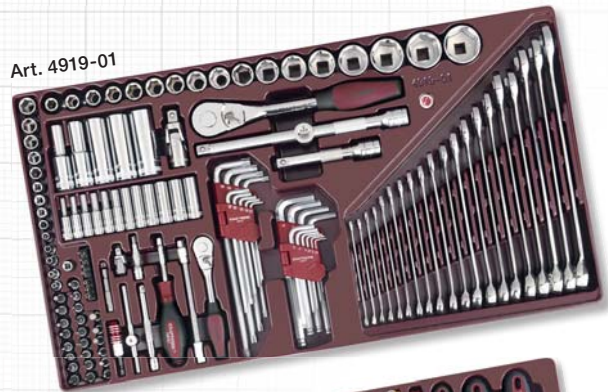

Service-Werkstattwagen

bestückt

Servante spéciale d'atelier

équipée

Carrello di servizio

con utensili

Art.			PCS
3917-4919	3917	4919-01, 4919-02	160

Karosserie-Werkstattwagen

universell bestückt mit Karosserie-Spezial-Werkzeugsatz in 3. Schublade

Chariot pour atelier de carrosserie

composition universelle avec en plus un jeu d'outils spécial carrosserie dans le 3ème tiroir

Carrello per carrozziere

con utensili universali e set di utensili speciali per carrozzerie nel 3° cassetto

Art.			PCS
3917-4919+3	3917	4919-01, 4919-02, 4919-03	176

	L1 / mm	L2 / mm	L3 / mm	kg
	792	445	960	160
A	690	410	104	40
B	650	355	45	20
C	650	355	68	30
D	650	355	100	30
E	768	410		40

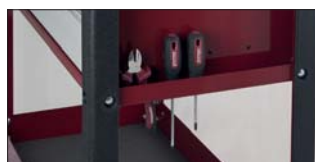

Schale mit Steck-
und Schraubenschlüssel

Coquille de clés et douilles

Assortimento di chiavi a bussola
e chiavi combinate



132
PCS

ergokraft

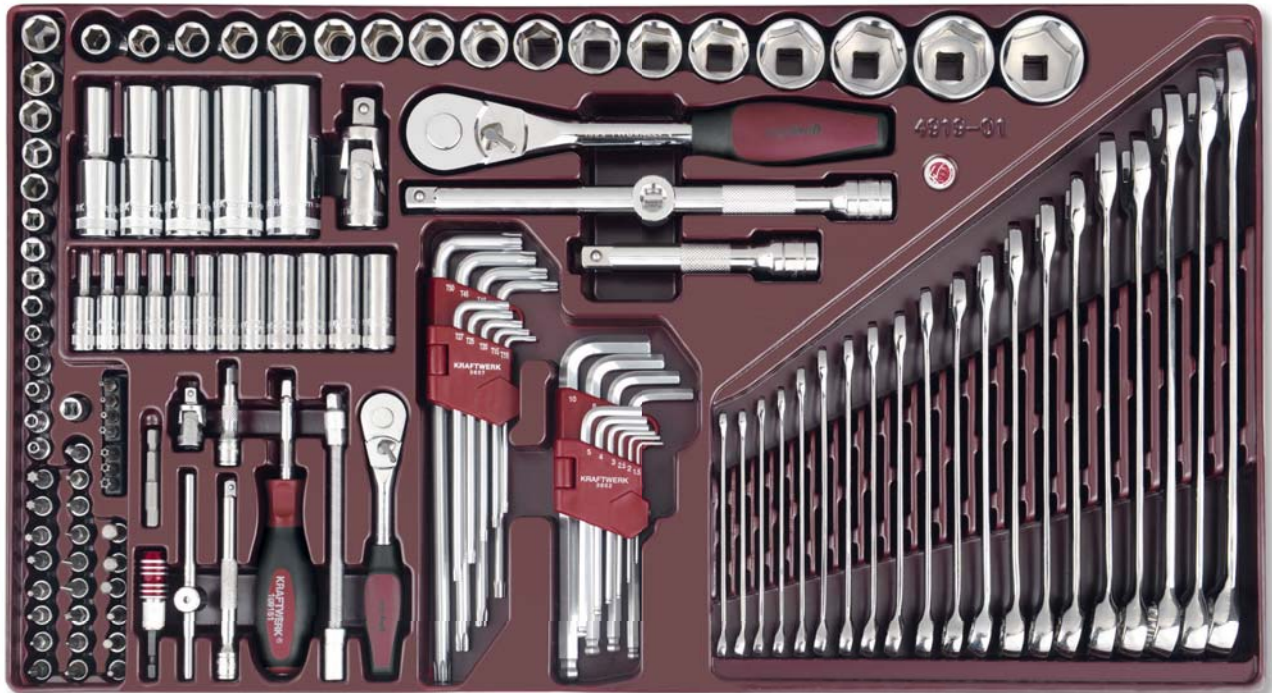

- 14 3.5-4-4.5-5-5.5-6-7-8-9-10-11-12-13-14 mm
- 12 4-4.5-5-5.5-6-7-8-9-10-11-12-13 mm
- 3 4-5.5-6.5 mm
- 3 PH 1-2-3
- 3 PZ 1-2-3
- 8 T8-T10-T15-T20-T25-T27-T30-T40
- 6 3-4-5-6-7-8 mm
- 1/4" 1/4"
- 1/4" 1/4"
- 2 50 mm / 100 mm
- 150 mm
- 115 mm
- 1/4" 1/4"
- 7 T10-T15-T20-T25-T27-T30-T40
- 1/4" 1/4"
- 1/4" 1/4"
- Art. 3200

- 17 10-11-12-13-14-15-16-17-18
19-21-22-24-27-30-32-34 mm
- 5 10-13-17-19-22 mm
- 1/2" 1/2"
- 2 125 mm / 250 mm
- 3/8" 1/2"
- Art. 3220
- Art. 3602
1.5-2-2.5-3-4-5-6-7-8-10 mm
- Art. 3607
T10-T15-T20-T25-T27
T30-T40-T45-T50

- DIN 3113**
- Art. 3505 5.5 mm
- Art. 3506 6 mm
- Art. 3507 7 mm
- Art. 3508 8 mm
- Art. 3509 9 mm
- Art. 3510 10 mm
- Art. 3511 11 mm
- Art. 3512 12 mm
- Art. 3513 13 mm
- Art. 3514 14 mm
- Art. 3515 15 mm
- Art. 3516 16 mm
- Art. 3517 17 mm
- Art. 3518 18 mm
- Art. 3519 19 mm
- Art. 3520 20 mm
- Art. 3521 21 mm
- Art. 3522 22 mm
- Art. 3523 23 mm
- Art. 3524 24 mm

Art.

4919-01

Schale mit Schraubendreher,
Zangen und Schlagwerkzeug

28
PCS

ergokraft

Coquille de tournevis, pinces et outils de frappe

Assortimento di cacciaviti, pinze e martelli



DIN ISO 5746

Art. 3281-180 180 mm



DIN ISO 5749

Art. 3282-160 160 mm



DIN ISO 8976

Art. 3290-250 250 mm



S2

Art. 4110-1 0.6 x 3 mm
Art. 4110-2 0.8 x 4 mm
Art. 4110-3 1.0 x 5 mm
Art. 4110-4 1.1 x 6 mm
Art. 4110-5 1.2 x 8 mm

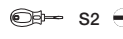

S2

Art. 4112-2 1.1 x 6 mm

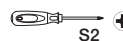

S2

Art. 4115-1 PH1
Art. 4115-2 PH2

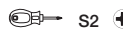

S2

Art. 4117-2 PH2



GS

Art. 2138 100-250 V



GS

Art. 2139 12 V



DIN ISO 5745

Art. 3285-200 200 mm



DIN ISO 5232

Art. 3289-160 160 mm



DIN 6450 Form C

Art. 1350-2 2 mm
Art. 1350-3 3 mm
Art. 1350-4 4 mm
Art. 1350-5 5 mm
Art. 1350-6 6 mm
Art. 1350-8 8 mm



DIN 7250

Art. 1358-2 No. 2

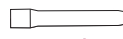

DIN 6451/53

Art. 3380-18 18 mm
Art. 3380-22 22 mm

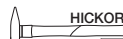

DIN 1041

Art. 2305 500 g

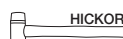

HICKORY

Art. 2336 Ø 35 mm



Art. 4700-0316 3 m x 16 mm









Art.

4919-02





Karosserie-Spezial-Werkzeugschale
 Coquille d'outils spéciaux carrosserie
 Vassoio di utensili speciali per carrozziere

16
PCS

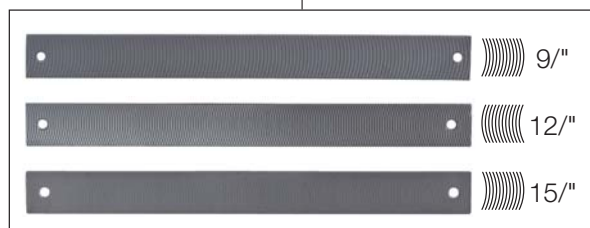

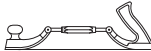
-  1 Handfaust Keilform
Tas de carrossier épinçoir
Tasso a cuneo
-  1 Handfaust Kommaform
Tas de carrossier virgule
Tasso a virgola
-  1 Handfaust Zehenform
Tas de carrossier américain
Tasso rettangolare bombato
-  1 Spann- und Schlichthammer
Marteau à planer et à débosser
Martello per carrozziere
con testa piane tonda e quadra
-  1 Schlicht- und Treibhammer
Marteau à boule combi à débosser
Martello per carrozziere
con testa tonda piana e penna a punta
-  1 Ausbeul- und Planierhammer geriffelt
Marteau cannelé à débosser et planer
Martello per carrozziere
con testa quadra zigrinata
-  1 Ausbeul- und Planierhammer gerade
Marteau plan à débosser et à planer
Martello per carrozziere
con testa quadra liscia
-  1 Ausbeul- und Planierhammer gewölbt
Marteau bombé à débosser et à planer
Martello per carrozziere
con testa quadra liscia e convessa



-  1 Karosseriefeilen-Spannhalter 350 mm
Monture pour limes fraisées 350 mm
Portalima per carrozziere, piatta flessibile,
350 mm
-  3 Karosserie-Feilenblatt
Lime de carrossier
Lima per carrozzeria,
Karosserie-Löffeleisen
Cuillère de carrosserie
Leva a cucchiaio carrozzeria
-  1 Karosserie-Meissel
Burin de carrosserie
Scalpello extrapiatto con tagliente
diritto e paramano
-  1 Mini-Druckluft-Ausblaspistole
mit Turbo-Power-Düse
*Mini soufflette à air comprimé
avec buse turbo*
Mini pistola tascabile di soffiaggio, ad aria
compressa, con ugello effetto turbo.
-  1 Abbrechklingen-Messer
Cutter à lame sécable
Cutter universale a lame a settori

Art.

4919-03

1/4" 1/2" 1/4" 5/16" **339**
PCS

Werkstattswagen

Kompakter, stabiler mit 7 kugelgelagerten und einzeln verriegelbaren Schubladen, bestückt mit 339 KRAFTWERK Junior Qualitäts-Werkzeugen. Die Werkzeuge sind schüttestfest eingebettet in 4 Schubladen in speziell hochverdichteten, zweifarbigen und übersichtlichen Weich-Schaumstoff-Einlagen (EVA).

Servante d'atelier

Servante d'atelier compacte et robuste avec 7 tiroirs sur roulements à billes verrouillables individuellement et équipés de 339 outils de qualité KRAFTWERK Junior. Les outils sont répartis dans 4 tiroirs et intégrés dans des inserts en mousse souple bicolore haute densité anti vibrations.

Carrello

Carrello portautensili compatto e stabile con 7 cassetti su cuscinetti a sfera e blocco individuale, fornito di 339 utensili di qualità KRAFTWERK Junior. Gli attrezzi sono riposti su 4 cassetti in altrettanti moduli anti vibrazione in materiale schiumoso bicolore ad alta densità EVA.





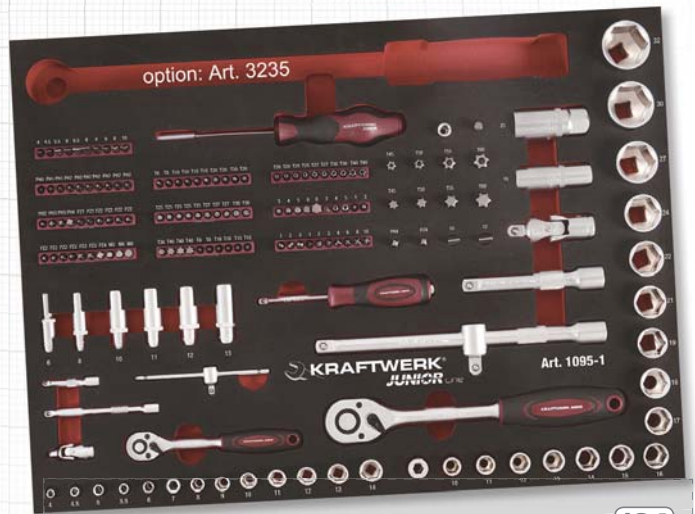







Art.		
1095	1907	7

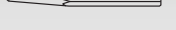

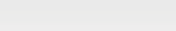
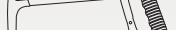
1/4"		13	4-4.5-5-5.5-6-7-8-9 10-11-12-13-14 mm	164 PCS
		6	6-8-10-11-12-13 mm	
			1/4" 1/4"	
			1/4" 1/4"	
		2	50 mm / 100 mm	
			115 mm	
			1/4"	
45			Art. 1005	
			1/4" 1/4"	
		6	4-4.5-5.5-6-6.5-8 mm	
		6	2xPH1-2xPH2-2xPH3	
		6	2xPZ1-2xPZ2-2xPZ3	
		24	2xT8-2xT10-2xT15-4xT20 5xT25-3xT27-3xT30-3xT40	
		15	TS10-2xTS15-2xTS20-3xTS25 2xTS27-3xTS30-2xTS40	
		5	3-4-5-6-8 mm	
		3	3-4-5 mm	
		4	No. 4-6-8-10	
		4	No. 1-2-3-4	
		3	No. 1-2-3	
		2	R1-R2	
		3	M5-M6-M8	
		3	6-8-10 mm	
			1/4" x 100 mm	
1/2"		16	10-11-12-13-14-15-16-17-18 19-21-22-24-27-30-32 mm	
		2	16 / 21 mm	
			1/2" 1/2"	
		2	125 mm / 250 mm	
			3/8" 1/2"	
45			Art. 1025	
			1/2" 5/16"	
5/16"		2	10/12 mm	
			PH4	
			PZ4	
		4	T45-T50-T55-T60	
		4	T45-T50-T55-T60	



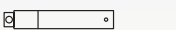











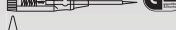







48
PCS

-  14 6-8-9-10-11-12-13-14-15-16-17-18-19-22 mm
-  2 18 / 22 mm
-  No.2 x 120 mm
-  2 x 115 mm 5 x 165 mm
-  6 3 x 125 mm 6 x 180 mm
-  4 x 150 mm 8 x 180 mm
-  12" x 300 mm
-  3 18 mm
-  10 18 mm
-  9 mm
-  10 9 mm

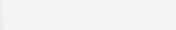
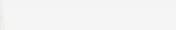
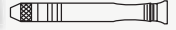
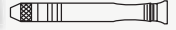

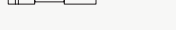











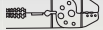

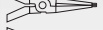
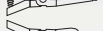
49
PCS

-  6  3,5 x 75, 4,0 x 100, 5,0 x 100
6,0 x 38, 6,0 x 150, 8,0 x 150 mm
-  3  PH1 x 75, PH2 x 100, PH2 x 38
-   110-250 V
-  300 g
-  PU 360 g 35 mm
-  Nylon 320 mm / No.2
-  6 160 mm
-  6  1-1,5-2-2,5-3-4 mm
-  4  PH000-PH00-PH0-PH1
-  3  PZ00-PZ0-PZ1
-  5  T3-T4-T5-T6-T7
-  4  T8-T9-T10-T15
-  5  1,3-1,5-2-2,5-3 mm
-  107 mm
-  105 mm
-  9 LED's



78
PCS

-  **DIN ISO 5749** 160 mm
-  **DIN ISO 5746** 180 mm
-  **DIN ISO 5745** 200 mm
-  250 mm
-  225 mm
-  185 mm
-  180 mm
-  180 mm
-  170 mm
-  170 mm
-  9  1,5-2-2,5-3-4-5-6-8-10 mm
-  9  T10-T15-T20-T25-T27-T30
T40-T45-T50
-  50

1/4" 1/2" 1/4" **266**
PCS

Werkzeugwagen Junior

bestückt, mit Standard-EVA-Einlagen

Servante Junior

équipée, avec mousses EVA standard

Carrello Junior

con assortimento di utensili ed inserti EVA standard



- 1/4" 14 3.5-4-4.5-5-5.5-6-7-8-9-10-11-12-13-14 mm
- 12 4-4.5-5-5.5-6-7-8-9-10-11-12-13 mm
- 3 4-5-5-6.5 mm
- 3 PH 1-2-3
- 3 PZ 1-2-3
- 8 T8-T10-T15-T20-T25-T27-T30-T40
- 6 3-4-5-6-7-8 mm
- 1/4" 1/4"
- 1/4" 1/4"
- 2 50 mm / 100 mm
- 150 mm
- 105 mm
- 1/4" 1/4"
- 1/4" 1/4"

- 72 Art. 3799
- 60 Art. 4000B



- 1/2" 17 10-11-12-13-14-15-16-17-18
19-21-22-24-27-30-32-34 mm
- 9 10-13-14-15-16-17-18-19-22 mm
- 1/2" 5/16"
- 1/2" 1/2"
- 2 125 mm / 250 mm
- 3/8" 1/2"
- 60 Art. 4020B

- 1/4" 6 4-4.5-5.5-6-6.5-8 mm
- 4 PH 1-2-3-4
- 4 PZ 1-2-3-4
- 8 T8-T10-T15-T20
T25-T27-T30-T40
- 8 T8-T10-T15-T20
T25-T27-T30-T40
- 6 3-4-5-6-7-8 mm
- 6 2-2.5-3-4-5-6 mm
- 6 5/64"-3/32"-7/64"-1/8"-9/64"-5/32"
- 3 No. 6-8-10
- 4 No. 1-2-3-4
- 4 No. 4-6-8-10



Art.		
1907-4921EVA	1907	7



ergokraft



44
PCS



DIN 3113

Art. 3505	5.5 mm	Art. 3511	11 mm	Art. 3517	17 mm	Art. 3524	23 mm
Art. 3506	6 mm	Art. 3512	12 mm	Art. 3518	18 mm	Art. 3527	24 mm
Art. 3507	7 mm	Art. 3513	13 mm	Art. 3519	19 mm	Art. 3530	27 mm
Art. 3508	8 mm	Art. 3514	14 mm	Art. 3520	20 mm	Art. 3531	30 mm
Art. 3509	9 mm	Art. 3515	15 mm	Art. 3521	21 mm	Art. 3532	32 mm
Art. 3510	10 mm	Art. 3516	16 mm	Art. 3522	22 mm		



DIN 2936 S2

Art. 3602
1.5-2-2.5-3-4-5-6-7-8-10 mm



ergokraft

DIN 3117 / ISO 6787	
Art. 3572	150 mm / 6"
Art. 3573	200 mm / 8"

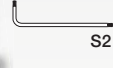

S2

Art. 3608
T10-T15-T20-T25-T27
T30-T40-T45-T50

ergokraft



18
PCS



DIN ISO 5746

Art. 3281-180 180 mm



DIN ISO 5749

Art. 3282-130 130 mm
Art. 3282-160 160 mm



DIN ISO 5745

Art. 3285-200 200 mm



DIN ISO 5745

Art. 3286-200 200 mm/45°



DIN ISO 5232

Art. 3289-160 160 mm



S2

Art. 4110-1	3 x 75 mm
Art. 4110-2	4 x 100 mm
Art. 4110-3	5 x 100 mm
Art. 4110-4	6 x 150 mm
Art. 4110-5	8 x 150 mm
Art. 4110-6	10 x 200 mm



S2

Art. 4112-2	1.1 x 6 x 38 mm
-------------	-----------------



S2

Art. 4115-1	PH1 x 75 mm
Art. 4115-2	PH2 x 100 mm



S2

Art. 4117-2	PH2 x 38 mm
-------------	-------------



S2

Art. 4128	1/4" x 100 mm
-----------	---------------



S2

Art. 2138	110-250 V
-----------	-----------

ergokraft



22
PCS



DIN 6450 Form C

Art. 1350-2	2 mm
Art. 1350-3	3 mm
Art. 1350-4	4 mm
Art. 1350-5	5 mm
Art. 1350-6	6 mm
Art. 1350-8	8 mm



DIN 6458

Art. 1355-2	2 mm
Art. 1355-3	3 mm
Art. 1355-4	4 mm
Art. 1355-5	5 mm
Art. 1355-6	6 mm



DIN 7250

Art. 1358-1	No. 1
Art. 1358-2	No. 2



DIN 6451/53

Art. 3380-18	18 mm
Art. 3380-22	22 mm



HICKORY

DIN 1041

Art. 2303	300 g
-----------	-------



HICKORY

DIN 1041

Art. 2336	Ø 35 mm
-----------	---------



DIN 7261

Art. 4320-1	320 mm
-------------	--------



DIN 7261

Art. 4320-2	320 mm
-------------	--------



DIN 7261

Art. 4320-3	320 mm
-------------	--------



DIN 7261

Art. 4320-4	320 mm
-------------	--------



DIN 7261

Art. 4320-5	320 mm
-------------	--------

ergokraft



30
PCS



Art. 4321



Art. 3310
9 mm

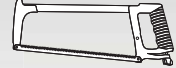

Art. 3305
400 mm

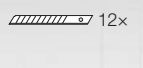

Art. 3313
9 mm



ergokraft

Art. 3308-1



Art. 3312
18 mm



HSS-Bimetall

Art. 3316-24
300 mm



Art. 3314
18 mm



ergokraft

Art. 2240



Art. 5433
3-30 mm CU



Art. 5470
Ø 6-40 mm



- 13 4-4.5-5-5.5-6-7-8-9-10-11-12-13-14 mm
- 6 6-8-10-11-12-13 mm
- 1/4" 1/4"
- 100 mm
- 1/4" 1/4"
- 1/4" 1/4"
- (45) Art. 1005

- 1/4" 1/4" 1/4"
- 1/4" 1/4"

- 1/2" 16 10-11-12-13-14-15-16-17-18
19-21-22-24-27-30-32 mm
- 2 16 mm / 21 mm
- 1/2" 1/2"
- 2 125 mm / 250 mm
- 3/8" 1/2"
- 1/2" 5/16"
- (45) Art. 1025
- Art. 1110-1 3.2 x 75 mm
Art. 1110-2 4.0 x 100 mm
Art. 1110-3 5.0 x 100 mm
Art. 1110-4 6.0 x 150 mm
Art. 1110-5 8.0 x 150 mm
- Art. 1112-2 6.0 x 38 mm
- Art. 1115-1 PH1
Art. 1115-2 PH2
- Art. 1117-2 PH2
- Art. 2138 110-250 V

- 5/16" 4 mm
- 4 2-2.5-3-4 mm Art. 3180
- 3 PH00-2xPH0
- 2 PZ00-PZ0
- 6 T6-T7-T8-T9-T10-T15
- 3 1.5-2-2.5 mm 30°
- 3 1.5-2-2.5 mm
- 4 mm

286
PCS

Werkstattwagen
praxisbezogen bestückt
mit 286 Qualitäts-Werkzeugen

Servante
avec assortiment pratique
de 286 outils de qualité

Carrello
equipaggiato con 286
utensili professionali



Art.		
1097	2907	7







S2
quality

42
PCS

 20 5.5-6-7-8-9-10-11-12-13-14-15
16-17-18-19-20-21-22-23-24 mm

  
1.5-2-2.5-3-4-5-6-8-10 mm
T10-T15-T20-T25-T27-T30-T40-T45-T50

 Art. 1281-180 180 mm
DIN ISO 5746

 Art. 1282-160 160 mm
DIN ISO 5749

 Art. 1285-200 200 mm
DIN ISO 5745

 Art. 1289-160 160 mm
DIN ISO 5232



CrV

44
PCS

 Art. 1350-2 2 mm
DIN 6450 Form C Art. 1350-3 3 mm
Art. 1350-4 4 mm
Art. 1350-5 5 mm
Art. 1350-6 6 mm
Art. 1350-8 8 mm

 Art. 1358-2 No. 2
DIN 7250

 Art. 3380-18 18 mm
DIN 6451/53 Art. 3380-22 22 mm

 **HICKORY** Art. 2303
DIN 1041  300 g

 **HICKORY** Art. 2336
Ø 35 mm

 Art. 4320-1 320 mm
DIN 7261

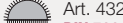
 Art. 4320-2 320 mm
DIN 7261

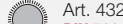
 Art. 4320-3 320 mm
DIN 7261

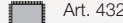
 Art. 4320-4 320 mm
DIN 7261

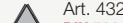
 Art. 4320-5 320 mm
DIN 7261

 Art. 4321

 Art. 3305
300 mm

 Art. 3308-1
ergokraft

 Art. 3316-24
300 mm
HSS-Bimetall

 Art. 3310
9 mm

 12x Art. 3313
9 mm

 Art. 3312
18 mm

 5x Art. 3314
18 mm

 Art. 2240
ergokraft

Werkzeugwagen

bestückt

Servante

équipée

Carrello

con utensili



Art.		
1096	1906	6



- 13 4-4.5-5-5.5-6-7-8-9-10-11-12-13-14 mm
- 6 6-8-10-11-12-13 mm
- 1/4" 1/4"
- 2 50 mm / 100 mm
- 1/4" 1/4"
- 1/4" 1/4"
- 1/4" 1/4"
- (45) Art. 1005





- 16 10-11-12-13-14-15-16-17-18-19-21-22-24-27-30-32 mm
- 2 16 mm / 21 mm
- 1/2" 5/16"
- 1/2" 1/2"
- 2 125 mm / 250 mm
- 3/8" 1/2"
- (45) Art. 1025





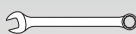

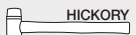
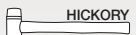
- 1.5-2-2.5-3-4-5-6-8-10 mm
- T10-T15-T20-T25-T27-T30-T40-T45-T50

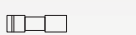
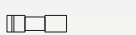

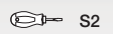

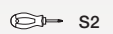

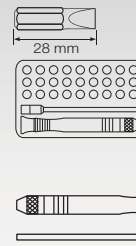

62
PCS

-  14 6-8-9-10-11-12-13-14
15-16-17-18-19-22 mm
-  **HICKORY** Art. 2303 300 g
DIN 1041 
-  **HICKORY** Art. 2336 Ø 35 mm
-  Art. 4320-1
-  Art. 4321
-  9 LED's

-  **S2** Art. 1110-1 3.2 x 75 mm
Art. 1110-2 4.0 x 100 mm
Art. 1110-3 5.0 x 100 mm
Art. 1110-4 6.0 x 150 mm
Art. 1110-5 8.0 x 150 mm
-  **S2** Art. 1112-2 6.0 x 38 mm
-  **S2** Art. 1115-1 PH1
Art. 1115-2 PH2
-  **S2** Art. 1117-2 PH2
-   Art. 2138 100-250 V















- 6  1-1.5-2-2.5-3-4 mm
- 4  PH000-PH00-PH0-PH1
- 3  PZ00-PZ0-PZ1
- 5  T3-T4-T5-T6-T7
- 4  T8-T9-T10-T15
- 5  1.3-1.5-2-2.5-3 mm
107 mm
105 mm

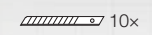

90
PCS

-  **DIN ISO 5746** Art. 1281-180 180 mm
-  **DIN ISO 5749** Art. 1282-160 160 mm
-  **DIN ISO 5745** Art. 1285-200 200 mm
-  Art. 2221-250 250 mm
-  Art. 220 mm

-  Art. 1350-2 2 mm
-  **DIN 6450 Form C** Art. 1350-3 3 mm
- Art. 1350-4 4 mm
- Art. 1350-5 5 mm
- Art. 1350-6 6 mm
- Art. 1350-8 8 mm
-  Art. 1358-2 2 mm
-  **DIN 6458** Art. 3380-18 18 mm
-  **DIN 6451/53** Art. 3380-22 22 mm

-  Art. 3305 300 mm  **50**
-  Art. 3310 9 mm
-  10x Art. 3313 9 mm
-  Art. 3312 18 mm
-  10x Art. 3314 18 mm
-  **ergokraft** Art. 2240

Mehrzweck- Etagen-Transportwagen

- 3 grosse Tablare aus Polypropylène/Fiberglas
- sehr stabile Konstruktion mit Aluminiumstangen
- universell einsetzbar
- grosse Lenkrollen Ø 100 mm, davon 2 mit Feststellbremse
- Etagentragfähigkeit: 80 kg
- Wagentragfähigkeit: 160 kg

Chariot de transport à plateaux multi-usages

- 3 niveaux de stockage en polypropylène et fibre de verre
- Robuste, universel, tiges en aluminium
- Roues pivotantes de grand diamètre Ø 100 mm, dont 2 avec frein de blocage.
- Charge utile par plateau : 80 kg
- Charge utile pour l'ensemble : 160

Carrello aperto multiuso

- dotato di 3 grandi ripiani in polipropilene e lana di vetro
- costruzione molto solida per uso universale, aste in alluminio
- 4 ruote girevoli Ø 100 mm, di cui 2 con freno
- portata del ripiano: 80 kg
- portata totale del carrello: 160 kg



Art.	
3912	0

	L1 / mm	L2 / mm	L3 / mm
	910	480	1040
A	660	390	300

Mehrzweck-Etagen-Transportwagen

mit Zubehörsatz zur Auflage von Fenster- und Windschutzscheiben.

Chariot de transport à plateaux multi-usages avec le kit d'accessoires pour la pose et la dépose des fenêtres et pare-brise.

Carrello aperto multiuso

con kit di accessori per il trasporto di finestre e parabrezza.



Art.			
3912A			

	L1 / mm	L2 / mm	L3 / mm
	845	490	1015
L4	660	390	300



Abfalleimer

für Mehrzweck-Etagen-Transportwagen 3912
aus öl- und säureresistentem Polypropylen

Poubelle

pour chariot de transport à plateaux multi-usages 3912
en polypropylène, résistant à l'huile et à l'acide

Pattumiera

per carrello aperto multiuso 3912 in polipropilene,
resistente agli olii ed agli acidi

Art.	
3912-99	3912/3913

↕ L1 360 × L2 250 × L3 430 mm



19L

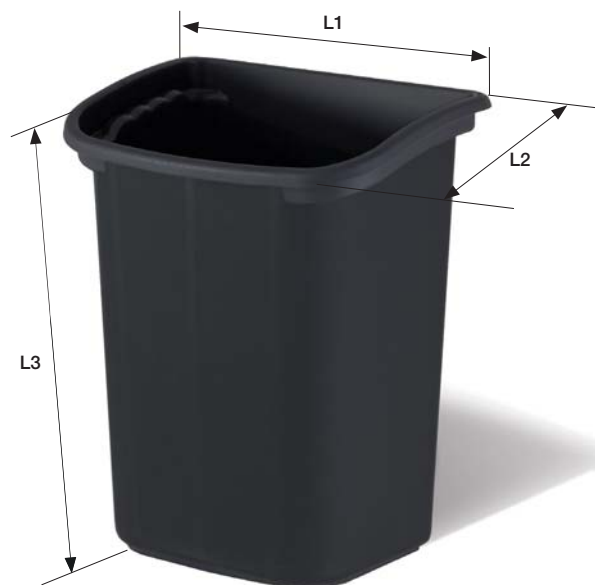



Ihr Fachhändler: | *Votre distributeur spécialisé :* |
Il vostro rivenditore specializzato: