

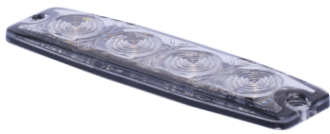

TRUCK & TRAILER PARTS LTD



LED LIGHTING PRODUCT CATALOGUE - 2017



EMERGENCY VEHICLE LIGHTING

COMMERCIAL VEHICLE LIGHTING

REVERSING SAFETY LIGHTING

www.3gttp.com



TRUCK & TRAILER PARTS LTD
www.3gttp.com



CONTENTS PAGE

ROTATING BEACONS	1
COMPACT XENON BEACONS	2
LED COMPACT BEACONS	3
LOW PROFILE XENON BEACONS	4
MINI LED LIGHTBARS	4 - 5
COMPACT ROTATING LIGHTBARS	6
ECLIPSE LED LIGHTBAR	6
TITAN - LED LIGHTBARS	7
LIGHTNING TITAN LIGHTBARS	8
ROTATING TITAN LIGHTBARS	9
LED MODULES	10 - 11

ROTATING BEACONS



Main Features



- EMC approved (ECE R10)
- 12V or Dual Voltage (12/24V) options
- Reverse polarity protection
- Robust design
- 70mph rated on magnetic version
- Meets IP56 international protection standards
- -30°C to +50°C extreme temperature reliability
- Unique maintenance free direct drive mechanism provides low noise operation

Applications



LA0001

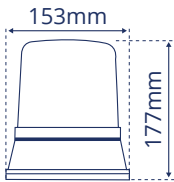

LA0002

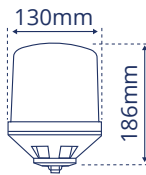

LA0003

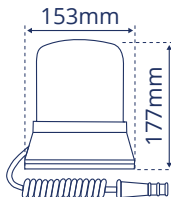

LA0004

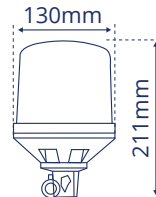

LA0005

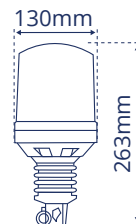

Part No	Voltage	Colour	Current Consumption 12/24V	Flash Rate (Per min)	Mounting
LA0001	12/24V	Amber	4.6/3.0A	180	Three Point
LA0002	12/24V	Amber	4.6/3.0A	180	Single Point
LA0003	12/24V	Amber	4.6/3.0A	180	Magnetic
LA0004	12/24V	Amber	4.6/3.0A	180	DIN
LA0005	12/24V	Amber	4.6/3.0A	180	Flexi DIN
LA0010	Amber Lens To Replace LA0001 / 2 / 3 / 4 / 5				

COMPACT XENON BEACONS

Low power consumption and high durability make this range ideal for plant and contracting, agriculture, utility and fleet vehicles. The low cost 2 Watt version is compact and rugged in design and ideal for off-road use.



Main Features

- Single flash
- Dual Voltage (12/24V)
- EMC approved (ECE R10)
- Low profile and compact design
- 70mph rated on magnetic version
- 2 Watt version
- Sealed against dust and moisture ingress
- Very low power consumption
- Meets IP56 international protection standards
- -30°C to +50°C extreme temperature reliability

Applications



Utility Vehicles



Agriculture



Plant & Contracting



Fleet



LA0011



LA0012



LA0013



LA0014



LA0015

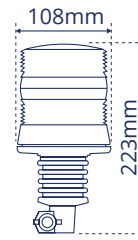
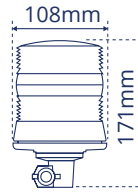
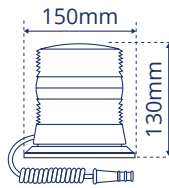
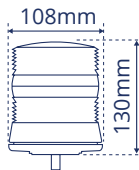
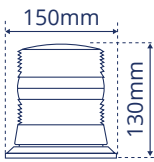

Part No	Voltage	Colour	Current Consumption 12/24V	Flash Rate (Per min)	Mounting
LA0011	10-30Vdc	Amber	0.175/0.150A	75	Three Point
LA0012	10-30Vdc	Amber	0.175/0.150A	75	Single Point
LA0013	10-30Vdc	Amber	0.175/0.150A	75	Magnetic
LA0014	10-30Vdc	Amber	0.175/0.150A	75	Magnetic
LA0015	10-30Vdc	Amber	0.175/0.150A	75	Flexi DIN

LED COMPACT BEACONS



Main Features

- EMC approved (ECE R10)
- Voltage 10-30Vdc
- Low profile and compact design
- 70mph rated on magnetic version
- Sealed against dust and moisture ingress
- Very low power consumption
- Double flash
- Meets IP56 international protection standards
- -30°C to +50°C extreme temperature reliability
- 2 year warranty

Applications

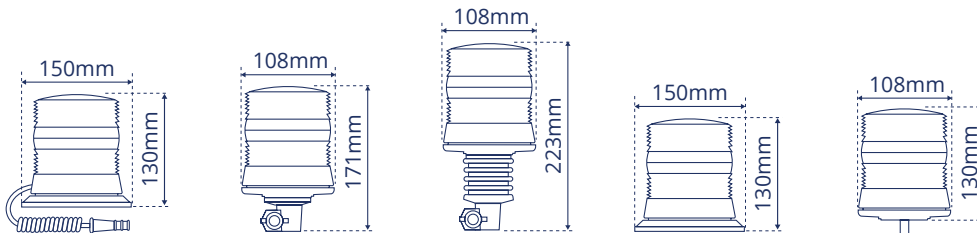

Part No	Voltage	Colour	Current Consumption 12/24V	Flash Rate (Per min)	Mounting
LA0020	10-30Vdc	Amber	0.6/0.3A	80	Magnetic
LA0021	10-30Vdc	Amber	0.6/0.3A	80	DIN
LA0022	10-30Vdc	Amber	0.6/0.3A	80	Flexi DIN
LA0023	10-30Vdc	Amber	0.6/0.3A	80	Three Point
LA0024	10-30Vdc	Amber	0.6/0.3A	80	Single Point

LOW PROFILE XENON BEACONS

Our high performance Low Profile Xenon Beacon is a cost effective solution for working vehicles of all types that require supplementary warning light devices.

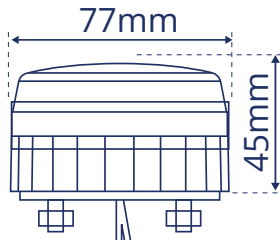

Applications



Refuse Truck



Utility Vehicles



Agriculture



Plant & Contracting



Fleet

Main Features

- EMC approved
- Multi-Voltage (10-100Vdc)
- 5 Watt version
- Vibration protected circuit
- Polycarbonate lens and base
- Sealed against dust and moisture ingress
- Meets IP67 protection standards
- -30 to +50°C extreme temperature reliability
- 12 month warranty

Part No	Voltage	Colour	Current Consumption (mA)					Mounting
			12V	24V	48V	80V	100V	
LA0050	10-100Vdc	Amber	260	230	150	120	100	Twin Bolt

MINI LED LIGHTBARS

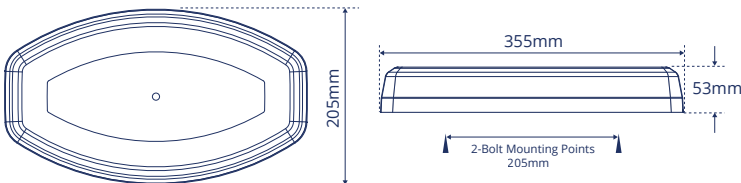

Main Features

- ECE R65 approved (Double Flash 2Hz Mode)
- EMC approved (ECE R10)
- Dual Voltage (12/24V)
- Clear polycarbonate lens
- Current consumption (Avg/Max): 2.9/5.8A @ 12V, 1.4/2.9A @ 24V
- 23 flash patterns
- 24 x 3W amber LEDs
- 2-Bolt models can be linked for synchronised flash
- 24 month warranty

Part No	Colour	Voltage	No. of Modules	No. of LEDs	Mounting
LA0360	Clear Lens	12/24V	4	24	Magnetic
LA0361	Clear Lens	12/24V	4	24	Twin Bolt

Applications



Refuse Truck



Utility Vehicles



Fleet

MINI LED LIGHTBARS CONTINUED

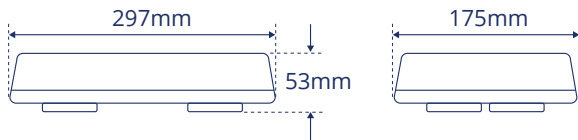

Part No	Colour	Voltage	No. of Modules	No. of LEDs	Mounting
LA0365	Clear Lens	12/24V	10	20	Magnetic
LA0366	Clear Lens	12/24V	10	20	Single Point

Main Features

- EMC approved (ECE R10)
- Dual Voltage (12/24V)
- Clear polycarbonate lens and ABS base
- Available in magnetic and single point fixings
- Extremely low power consumption
- 12 month warranty

Applications

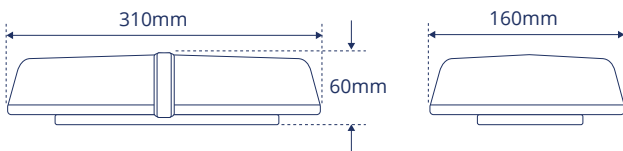

Part No	Colour	Voltage	No. of Modules	No. of LEDs	Mounting
LA0370	Clear Lens	12/24V	6	24	Magnetic
LA0371	Clear Lens	12/24V	6	24	Single Point

Main Features

- EMC approved
- Dual Voltage (12/24V)
- Clear polycarbonate lens
- Available in magnetic and single point fixings
- Aluminium base
- Low power consumption - 12V max 2A, 24V max 1A
- 8 flash patterns
- 24 x 1W amber LEDs
- Weatherproof and vibration resistant design
- 12 month warranty

Applications





COMPACT ROTATING LIGHTBARS

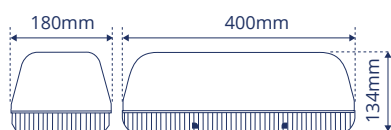
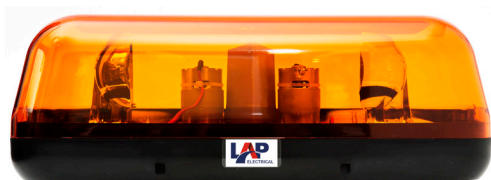

Part No	Colour	Voltage	Flash Rate (Per min)	Mounting	ECE R65
LA0385	Amber	12/24V	180	Single Point	✓
LA0386	Amber	12/24V	180	Magnetic	✓
LA0387	Amber	12/24V	180	Twin Bolt	✓

Main Features

- CE and 'E' approved (EMC)
- Dual Voltage (12/24V)
- Supplied with 12V halogen bulbs
- Reverse polarity protection
- Meets IP56 international protection standards
- -30°C to +50°C extreme temperature reliability
- 12 month warranty

Applications



ECLIPSE LED LIGHTBAR

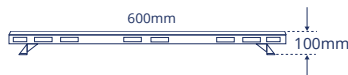
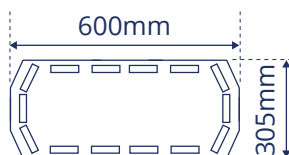

Main Features

- EMC approved (ECE R10)
- Dual Voltage (12/24V)
- 4 x 3W amber LEDs per module
- Clear lens
- Weatherproof and vibration resistant design
- Polycarbonate lens with aluminium base
- 2 year warranty

Applications



Part No	Size	Colour	No. of Modules	Voltage
LA0351	2ft (600mm)	Amber LED, Clear Lens	14	12/24V

TITAN - LED LIGHTBARS

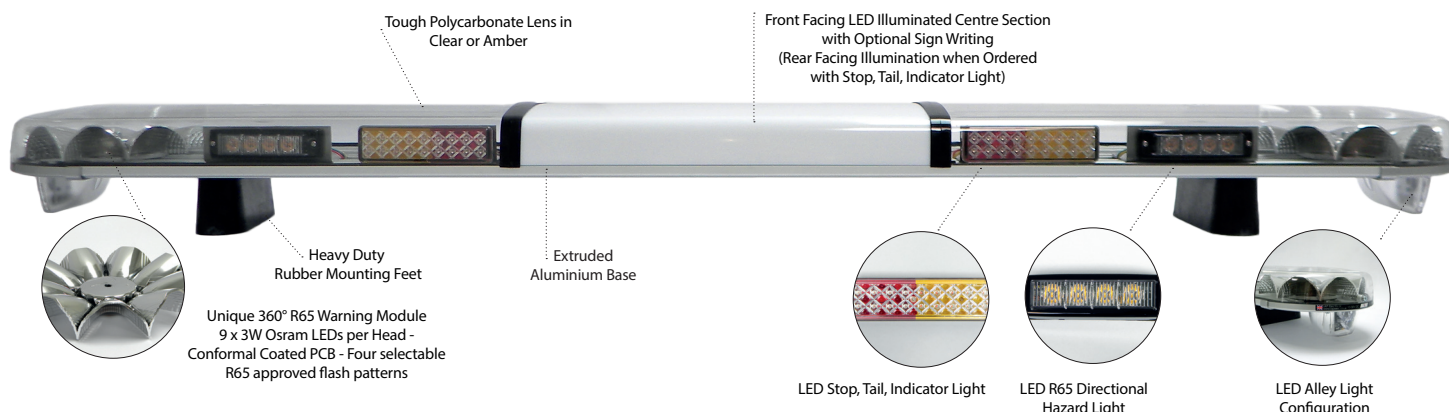

Main Features

- Dual Voltage (12/24V)
- Meets ECE R65 & EMC regulations (ECE R10)
- 360° high performance optics for improved safety
- Amber or clear polycarbonate lenses
- Extruded aluminium base
- Fully encapsulated electronic control module
- Long life LED technology
- Opal, clear or amber centre sections available
- 4 bolt mounting fix / High rise feet option
- Extreme temperature reliability -30° to +50°
- 3 year warranty
- 2ft Magnetic models available
- 2.5 metre multi-core cable

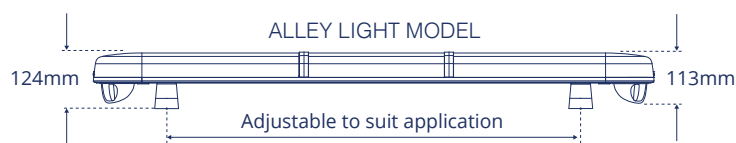

AVAILABLE UPON REQUEST

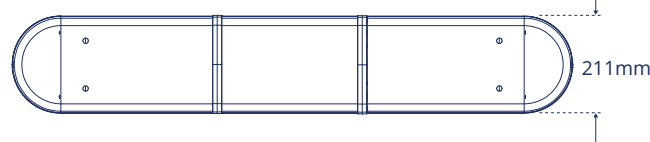

Applications



Refuse
Truck



Utility
Vehicles



Plant &
Contracting



Fleet

Part No	Size	Colour	No. of LED Modules	Voltage	ECE R65	Model
LA0300	2ft (610mm)	Amber LED, Clear Lens	2	12/24V	✓	Standard Model
LA0301	2ft (610mm)	Amber LED, Clear Lens	2	12/24V Magnetic Feet	✓	Standard Model
LA0305	3ft (915mm)	Amber LED, Clear Lens	2	12/24V	✓	Standard Model
LA0310	4ft (1220mm)	Amber LED, Clear Lens	2	12/24V	✓	Standard Model
LA0311	4ft (1220mm)	Amber LED, Clear Lens	2	12/24V Illuminated Centre	✓	Standard Model
LA0315	5ft (1524mm)	Amber LED, Clear Lens	2	12/24V	✓	Standard Model
LA0320	5ft (1524mm)	Amber LED, Clear Lens	4	12/24V	✓	Standard Model



TRUCK & TRAILER PARTS LTD
www.3gttp.com



LIGHTNING TITAN LIGHTBARS

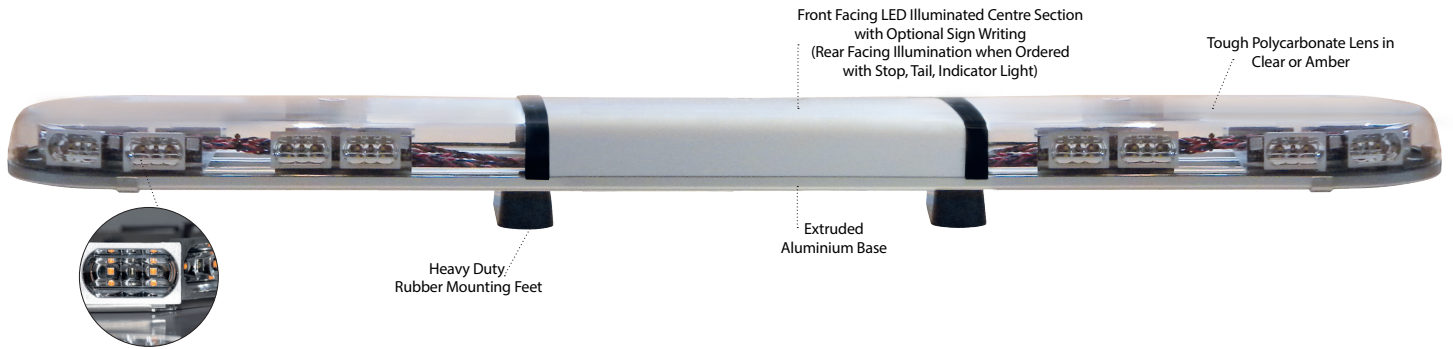

Main Features

- Dual Voltage (12/24V)
- Airport flash & cruise modes available
- Meets ECE R65 & EMC regulations (ECE R10)
- Extruded aluminium base
- Fully encapsulated electronic control module
- 4 bolt mounting fix / High rise feet option
- Extreme temperature reliability -30° to +50°
- 3 year warranty
- 2ft Magnetic models available
- 2.5 metre multi-core cable

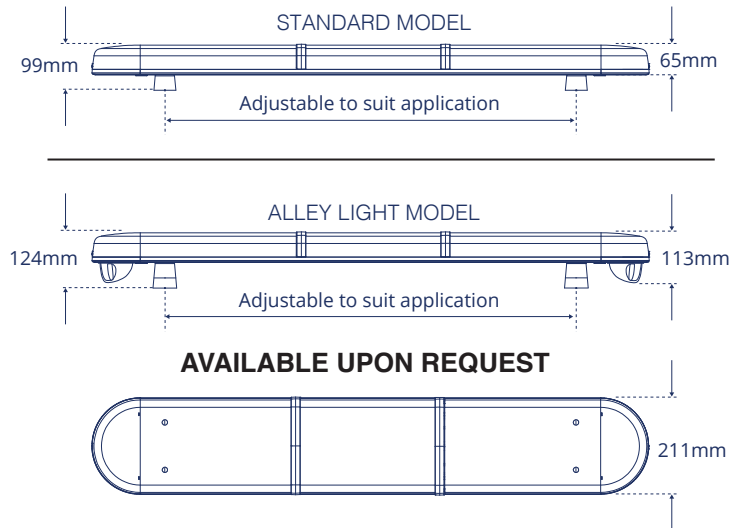

Applications



Part No	Size	Colour	No. of Twin LED Modules	Voltage	ECE R65	Model
LA0325	2ft (610mm)	Amber LED, Clear Lens	12	12/24V	✓	Standard Model
LA0326	2ft (610mm)	Amber LED, Clear Lens	12	12/24V Magnetic feet	✓	Standard Model
LA0330	3ft (915mm)	Amber LED, Clear Lens	12	12/24V	✓	Standard Model
LA0335	4ft (1220mm)	Amber LED, Clear Lens	12	12/24V	✓	Standard Model
LA0336	4ft (1220mm)	Amber LED, Clear Lens	12	12/24V Illuminated Centre	✓	Standard Model
LA0340	5ft (1524mm)	Amber LED, Clear Lens	12	12/24V	✓	Standard Model
LA0341	5ft (1524mm)	Amber LED, Clear Lens	12	12/24V Illuminated Centre	✓	Standard Model



TRUCK & TRAILER PARTS LTD
www.3gttp.com



ROTATING TITAN LIGHTBARS



ROTATING
TITAN
LIGHTBAR RANGE

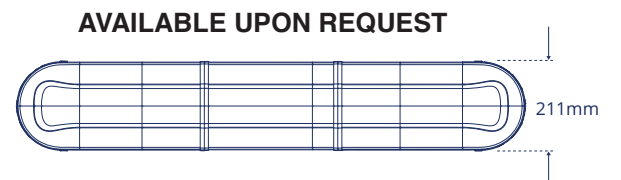
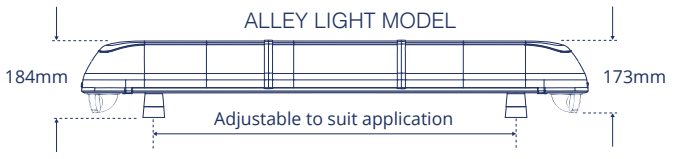
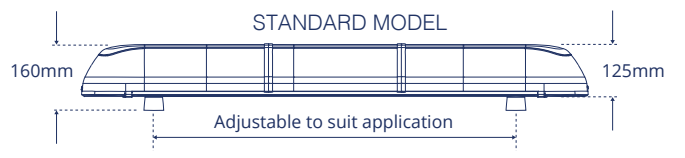
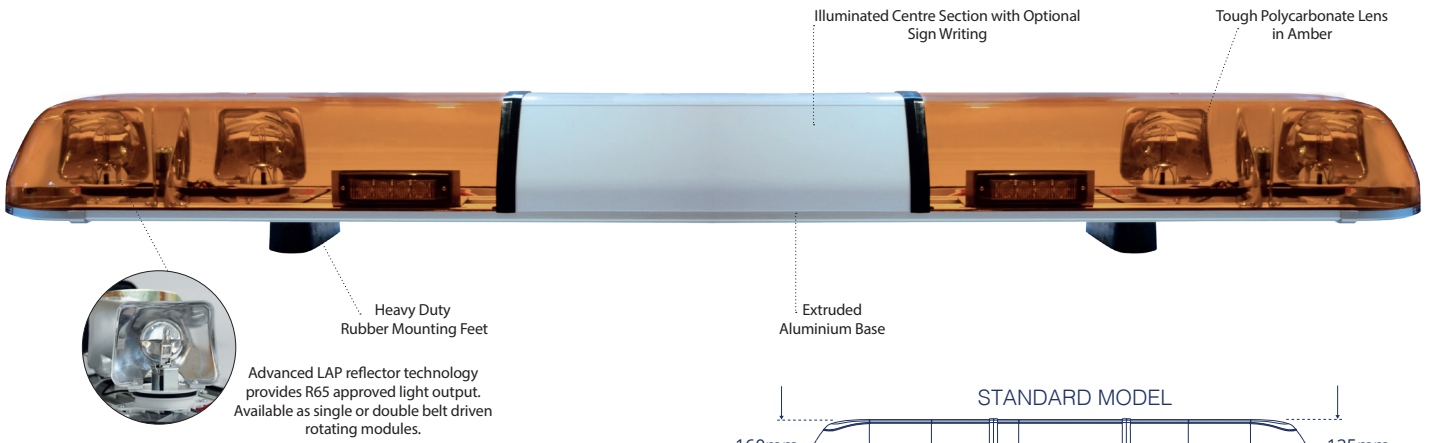

Main Features

- Meets ECE R65 & EMC regulations (ECE R10)
- Amber polycarbonate lens
- Extruded aluminium base
- Reverse polarity protection
- 4 bolt mounting fix / High rise feet option
- Extreme temperature reliability -30° to +50°
- 1 year warranty
- 2.5 metre multi-core cable
- Supplied with 12V halogen bulbs

Applications



Part No	Size	Colour	Voltage	ECE R65	Model
LA0375	2ft (610mm)	Amber Lens	12/24V	✓	Standard Model
LA0376	3ft (915mm)	Amber Lens	12/24V	✓	Standard Model
LA0377	3ft (915mm)	Amber Lens	12/24V Illuminated Centre (Halogen)	✓	Standard Model
LA0378	4ft (1220mm)	Amber Lens	12/24V	✓	Standard Model
LA0379	4ft (1220mm)	Amber Lens	12/24V Illuminated Centre (Halogen)	✓	Standard Model
LA0380	4ft (1220mm)	Amber Lens	12/24V Illuminated Centre (Halogen) 4 Head	✓	Standard Model
LA0381	5ft (1524mm)	Amber Lens	12/24V	✓	Standard Model
LA0382	5ft (1524mm)	Amber Lens	12/24V Illuminated Centre	✓	Standard Model

LED MODULES

LA0389 - Slimline LED Module

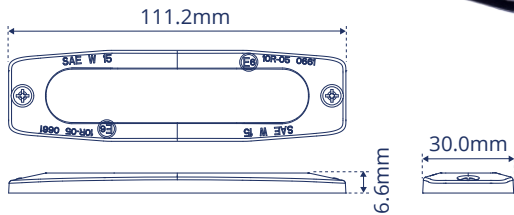
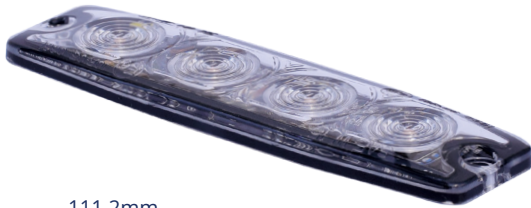

Applications



Refuse Truck



Utility Vehicles



Plant & Contracting



Fleet

Main Features

- EMC approved (ECE R10)
- 4 x LED Light
- Self-adhesive backing for quick mounting
- Built-in 24 selectable flash patterns in split or simultaneous flash
- Long life LEDs technology rated to 100,000 hours of operation
- Multiple units can be linked for synchronised / alternate flash
- Fully weatherproof and vibration resistant
- Aluminium base for efficient heat dissipation and maximum durability
- Max. Current: 0.65A @12VDC / 0.33A @24VDC
- 24 month warranty

Part No	Colour	Voltage
LA0389	Amber	12/24V

LA0391 - 5 Flash Pattern

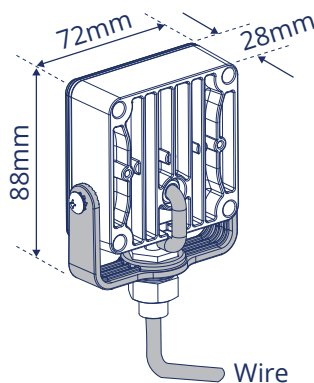

Applications



Refuse Truck



Utility Vehicles



Plant & Contracting



Fleet

Main Features

- EMC approved (ECE R10)
- LA0391: 4 x 3W LEDs - Double flash meets R65
- Steady on function
- Supplied with single point fix adjustable mounting bracket
- Multiple units can be linked for synchronised / alternate flash
- IP67 rated ingress protection
- Max. Current: 0.55A @ 12.8V / 0.26A @ 24V
- Polycarbonate lens with diecast housing
- 24 month warranty



Part No	Colour	Voltage	ECE R65
LA0391	Amber	12/24V	✓

LED MODULES CONTINUED

LA0388 - 10 Flash Patterns



Specifications:

- Lens: Polycarbonate
- Base: Aluminium
- Weight: 0.09Kg
- Current draw: 12V - 700mA
- Dimensions: 77 (w) x 29 (d) x 16mm (h)

Main Features

- EMC approved (ECE R10)
- ECE R65 approved
- 3 x LED Light
- IP56 rated ingress protection
- Multiple units can be linked for synchronised / alternate flash
- Single flash meets R65
- Supplied with on/off and flash pattern changing switches
- 12 month warranty



Applications



Refuse
Truck



Utility
Vehicles



Plant &
Contracting



Fleet

Part No	Colour	Voltage	ECE R65
LA0388	Amber	12/24V	✓



TRUCK & TRAILER PARTS LTD

3G Truck & Trailer Parts Ltd

Sandbeck Way, Hellaby Industrial Estate,
Hellaby, Rotherham,
S66 8QL, United Kingdom

Tel: +44 (0) 1709 702066

Fax: +44 (0) 1709 702488

Email: sales@3gttp.com

Facebook: Facebook.com/3gttp

Twitter: @3gtrucktrailer

www.3gttp.com