

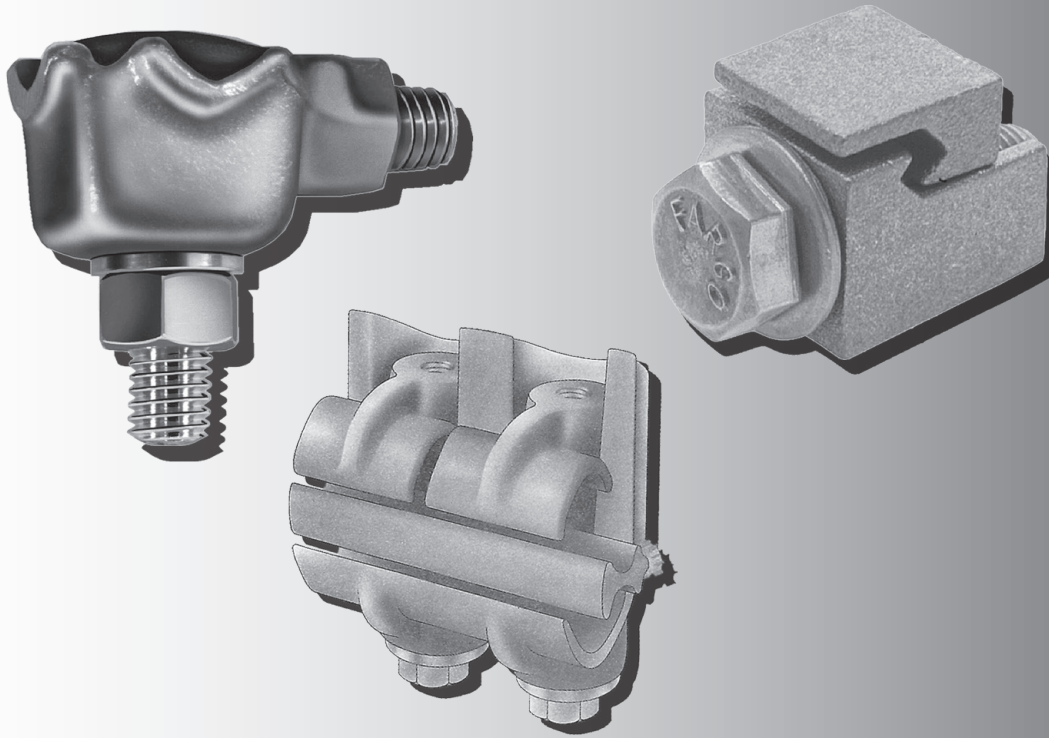

DISTRIBUTION CONNECTORS



SECTION D

GENERAL USE CONNECTORS

- Aluminum Vise-Type*
- Bronze Vise-Type*
- Bronze Grounding Clamps*
- Bronze Grounding Post*
- Aluminum Parallel Groove*
- Bonding Clamps*
- Bronze Parallel Groove*
- Bronze Set-Screw*
- Copper Set-Screw*
- Aluminum/Bronze Transformer SURD*
- Aluminum Specialty*



GENERAL USE VISE TYPE ALUMINUM SINGLE BOLT ALUMINUM TO ALUMINUM AND/OR ALUMINUM TO COPPER

ALUMINUM
GA9000

- Recommended for aluminum or aluminum to copper distribution, service or tap connections.
- Add Suffix "G" to catalog number for neoprene grommets for "hot" work. Grommet holds spacer bar in place during installation.
- Sealant is recommended on all connectors.
- Optional snap-on cover
- Optional - Class AA temperature rated per ANSI C119.4



Material: **Body** - Aluminum alloy
Spacer - Aluminum
Hardware - Stainless Steel "SS" suffix or Aluminum Alloy (std.)

Options: Snap-On Cover (See Column) (B-Suffix)
Torque-Head Bolts (Add "O" Suffix)
Grommets "G" suffix
"L" Inhibitor applied (std.)
"AA" - Class AA rated
Ex: GA9020GAASSB2 or GA9041GLOB3 construction

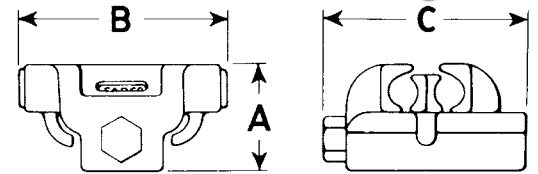

"G" Grommet Suffix

Optional grommet aids in positioning spacer bar for "hotstick" work or assembly. See note below.

DD
1

Product Data & Conductor Size

SINGLE BOLT ALUMINUM CONNECTORS										A INCHES (MM)	B INCHES (MM)	C INCHES (MM)	AP- PROX. WT. EACH LBS. (KG)	INSULATED SNAP-ON COVER CATALOG NUMBER
CATALOG NUMBER		CONDUCTOR RANGE												
		RUN				TAP								
STANDARD	CLASS AA	MAX.	MIN.	MAX.	MIN.	MAX.	MIN.	MAX.	MIN.					
ACSR	AL.	ACSR	AL.	ACSR	AL. or CU.	ACSR	AL. or CU.	ACSR	AL. or CU.					
GA9003L**	GA9003AA	4	2 Sol.	6	8 Sol.	4	2 Sol.	6	8 Sol.	7/8 (22.27)	1-1/4 (31.81)	1-3/4 (44.54)	.17 (.08)	GA9000B2**
GA9002L**	GA9002AA	2	1 Str.	6	6 Sol.	2	1 Str.	6	12 Sol.	1-1/8 (28.63)	1 7/8 (47.72)	2-1/8 (54.08)	.23 (.10)	GA9000B2**
GA9020LSS**	GA9020AASS	1/0	2/0 Str.	6	6 Sol.	1/0	2/0 Str.	6	6 Sol.	1-1/4 (31.81)	1-7/8 (47.72)	2-3/8 (60.44)	.34 (.15)	GA9000B2**
GA9040L**	GA9040AA	4/0	4/0 Str.	2	1 Str.	4/0	4/0 Str.	2	1 Str.	1-1/2 (38.18)	2-3/4 (69.99)	3-1/8 (79.53)	.55 (.25)	GA9000B3**
GA9041L**	GA9041AA	4/0	4/0 Str.	2	1 Str.	2/0	2/0 Str.	6	6 Sol.	1-1/2 (38.18)	3-3/8 (85.89)	3-1/8 (79.53)	.58 (.26)	GA9000B3**
GA9405L	GA9405AA	3/0	3/0 Str.	4	4 Str.	-	4 Str.	-	12 Sol.	1-1/2 (38.18)	1-7/8 (47.72)	2-1/2 (63.63)	.44 (.20)	GA9000B2**
GA9400L	GA9400AA	336,400	397,500	3/0	4/0 Str.	336,400	397,500	3/0	4/0 Str.	2-1/16 (52.50)	3-1/2 (89.08)	3-1/2 (89.08)	.78 (.35)	GA9000B3**
GA9401L	GA9401AA	336,400	397,500	3/0	4/0 Str.	4/0	266,800	6	6 Sol.	2-1/16 (52.50)	4 (101.80)	3-1/2 (89.08)	.84 (.38)	GA9000B3**
GA9842L**	GA9842AA	666,000	800,000	4/0	266,800	2/0	2/0	6	6 Sol.	2 (50.90)	3-5/8 (92.26)	3-3/4 (95.44)	.80 (.36)	GA9000B3**
GA9843L**	GA9843AA	666,000	800,000	4/0	266,800	4/0	4/0	2	1 Str.	2 (50.90)	3-5/8 (92.26)	3-3/4 (95.44)	.88 (.40)	GA9000B3**
CONNECTORS FOR SPECIAL APPLICATIONS														
GA9404L	GA9404AA	4/0	4/0	4	4 Str.	-	10 Sol.	-	12 Sol.	1-1/8 (28.63)	1-7/8 (47.72)	2-1/8 (54.08)	.39 (.18)	GA9000B2**
GA9844L		666,000	800,000	477,000	477,000	336,400	397,500	4/0	266,800	3 (76.35)	3 (76.35)	4-3/4 (120.89)	1.24 (.56)	GA9000B5**
GA9954L	GA9954AA	795,000*	954,000	-	795,000	-	336,400	-	1/0	3 (76.35)	3 (76.35)	4 3/4 (120.89)	1.24 (.56)	GA9000B5**

*795 ACSR 26/7

** RUS Listed

Feature: "G" - Neoprene grommets for "hotstick" work. Soft flexible grommets hold the spacer bar in position for easy installation of the run and tap. The grommets do not interfere with the smooth operation of the connector.



GENERAL USE VISE TYPE, TWO-BOLT EXTENDED RANGE ALUMINUM ALUMINUM TO ALUMINUM AND/OR ALUMINUM TO COPPER

ALUMINUM
GA9000

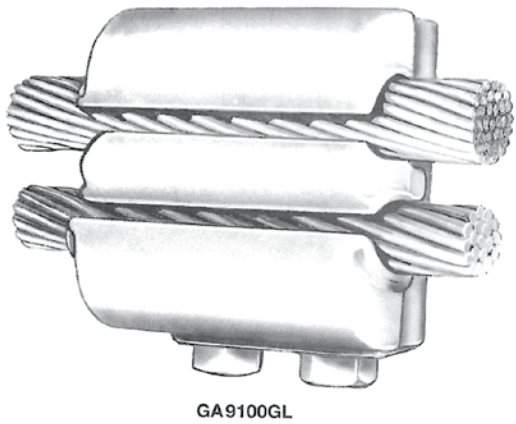

GA9100GL

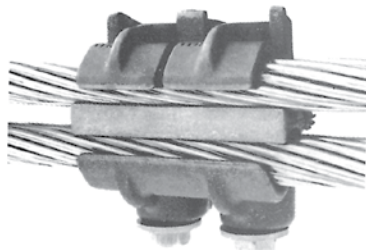

GA9520GL

- Heavy duty construction for aluminum to aluminum or aluminum to copper conductor connections.
- Sealant is recommended for all connections.

Material: Body - Aluminum alloy
Spacer - Aluminum
Hardware - Aluminum Alloy or Stainless steel

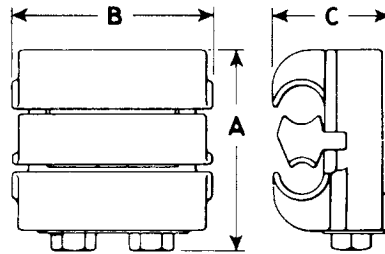

"A" Dimension depends on bolt extension/conductor size opening.



"G" Grommet Suffix
Optional grommet aids in positioning spacer bar for "hotstick" work or assembly. See note below.



GA9000Bx Series Snap-On Cover

Product Data & Conductor Size

ALUMINUM CONNECTORS FOR ALUMINUM TO ALUMINUM

CATALOG NUMBER		CONDUCTOR RANGE								APPROX. DIMENSIONS INCHES (MM)			APPROX. WT. EACH LBS. (KG)
		RUN				TAP				(NOMINAL) A (MM)	B (MM)	C (MM)	
		MAX.	MIN.	MAX.	MIN.	MAX.	MIN.	MAX.	MIN.				
STANDARD	CLASS AA	ACSR	AL.	ACSR	AL.	ACSR	AL. or CU.	ACSR	AL. or CU.	(NOMINAL) A (MM)	B (MM)	C (MM)	APPROX. WT. EACH LBS. (KG)
GA9520GL*	GA9520GAA*	477,000	600,000	4/0	4/0	477,000	600,000	4/0	4/0	4 (101.80)	4-1/4 (108.16)	2-1/2 (63.63)	1.44 (.65)
GA9521GL*	GA9521GAA*	477,000	600,000	4/0	250,000	4/0	266,800	4	4 Str.	4 (101.80)	4-1/4 (108.16)	2-1/2 (63.63)	1.52 (.69)
GA9820GL	GA9820GAA	795,000 [†]	800,000	336,400	477,000	795,000 [†]	800,000	336,400	477,000	5-1/2 (139.98)	4-1/2 (114.53)	2-3/4 (69.99)	2.40 (1.09)
GA9821GL	GA9821GAA	795,000 [†]	800,000	336,400	477,000	397,500 [†]	477,000	3/0	4/0	5-1/2 (139.98)	4-1/2 (114.53)	2-3/4 (69.99)	2.30 (1.04)
GA9100GL	GA9100GAA	1,272,000	1,500,000	636,000	795,000	1,272,000	1,500,000	636,000	795,000	5-3/4 (146.34)	6-1/4 (159.06)	2-7/8 (73.17)	4.50 (2.04)
GA9101GL	GA9101GAA	1,272,000	1,500,000	636,000	795,000	636,000	795,000	336,400	336,400	5-3/4 (146.34)	6-1/4 (159.06)	2-7/8 (73.17)	4.60 (2.09)

* For insulated Snap-On Cover - order Catalog No. GA9000B4.

[†] 26/7 ACSR

Feature: "G" - Neoprene grommets for "hotstick" work. Soft flexible grommets hold the spacer bar in position for easy installation of the run and tap. The grommets do not interfere with the smooth operation of the connector.

DD
2



GENERAL USE VISE TYPE BRONZE COPPER TO COPPER

BRONZE
GC5000
SERIES

- For copper connections-Splice, Loop deadend or service entrance tap or grounding connections
- One piece design for easier, faster installation
- Bolt head design for use with standard ratchet wrench
- Vise design achieves high connector pressure with low wrench force
- Easily installs with live line tools

Material: **Body** – Copper alloy
Hardware – Stainless Steel or Silicon Bronze alloy

Options: Suffix "P" Tin-plated



Connector with
Torque Head Bolt

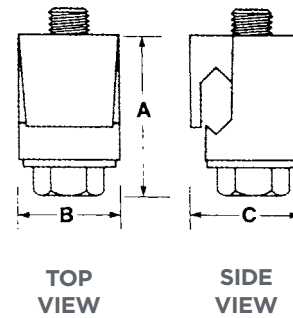

DD
3

Product Data & Conductor Size

CATALOG NUMBER	CONDUCTOR RANGE		DIA. RANGE (2 COND. COMBO.)	A (MM)	B (MM)	C (MM)	WT. EA. LB (KG)	BOLT HEAD (HEX.)
	MAX. 2 CONDUCTORS	MIN. 2 CONDUCTORS	DIA. EA. COND. MAX. - MIN.					
GC5008SH*	#8 STR.	#11 SOL.	.146" - .091" (3.72-2.32)	7/8" (22.7)	5/8" (15.91)	5/8" (15.91)	.06 (.03)	3/8" (10)
GC5006**	#6 SOL.	#10 SOL.	.162"-.101" (4.12-2.57)	1" (25.45)		3/4" (19.09)	.09 (.04)	
GC5006SH*						7/8" (22.27)	.16 (.07)	
GC5004**	#4 STR.	#8 SOL.	.232"-.128" (5.9-3.26)	1-1/4" (31.81)	3/4" (19.09)	1" (25.45)	.18 (.08)	9/16" (14)
GC5002**	#2 SOL.	#6 SOL.	.286"-.162" (7.28-4.12)	1-3/8" (34.99)		1-1/8" (28.63)	.28 (.13)	
GC5002S**	#2 STR.	#5 SOL.	.320"-.181" (8.14-4.61)	1-5/8" (41.36)		1-1/4" (31.81)		
GC5020**	1/0 STR.	#4 SOL.	.390"-.204" (9.93-5.19)	1-7/8" (47.72)	7/8" (22.27)	1-1/4" (31.81)	.48 (.22)	
GC5020S**	2/0 STR.	#3 SOL.	.438"-.229" (11.15-5.83)	2" (50.90)	1" (25.45)	1-3/8" (34.99)		
GC5040**	4/0 STR.	#1 SOL.	.552"-.289" (14.05-7.36)	2-1/8" (54.08)	1" (25.45)	1-3/8" (34.99)		

* SH suffix indicates a slotted hex-head bolt.

**RUS Listed

For tin-plated bronze connectors, add suffix "P" to catalog number (not available on GC5006S, GC5006SH and GC5008SH)

Note: All connectors will accept one or two of the conductors listed and any combination in between.



GENERAL USE – GROUNDING AND BONDING VISE TYPE BRONZE

BRONZE GC SERIES
GC100 / 200 / 5000

For copper to copper connections or conductor to conductor and conductor/cable sheath to bar.

Material: **Body** – Copper Alloy
Bolt – Stainless Steel or Silicon Bronze slotted head hex

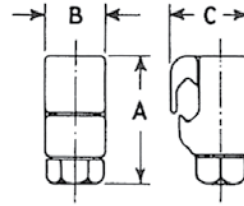

GC5000 Series

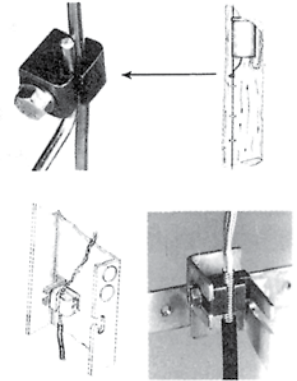

Product Data & Conductor Size

CATALOG NUMBER	RANGE				APPROX. DIMENSIONS INCHES					
	CONDUCTOR COMBINATIONS		CABLE SHEATH BONDING		A (MM)	B (MM)	C (MM)	BOLT		WT LB (KG)
	RUN	TAP						DIA.	WRENCH	
GC271**	4-6 4 Sol - 6 Str.	6-14	1 to 3	2 pair	1 (25.45)	5/8 (15.90)	3/4 (19.08)	1/4 (6.36)	3/8 (10)	.08 (.04)
GC5006SH**	6	6-14	1 to 3	2 pair	1 (25.45)	5/8 (15.90)	3/4 (19.08)	1/4 (6.36)	3/8 (10)	.09 (.04)
GC5006***	6	6-14	1 to 3	2 pair	1 (25.45)	5/8 (15.90)	3/4 (19.08)	1/4 (6.36)	3/8 (10)	.09 (.04)
GC5004***	4	4-8	1 to 3	2 pair	1-1/4 (31.81)	5/8 (15.90)	7/8 (22.26)	5/16 (7.95)	9/16 (14)	.16 (.07)
			1	5 pair						
GC5002**	2	2-6	-	-	1-3/8 (35.00)	3/4 (19.08)	1 (25.45)	5/16 (7.95)	9/16 (14)	.18 (.08)

* Slotted Head Bolt
† Complies with UL-467 and ETL listed
**RUS Listed

For Figure 8 or IM Cable – Insulation Piercing

The piercing teeth of the connector puncture the messenger insulation during tightening to form a positive ground without skinning.

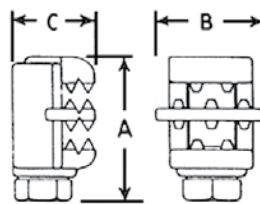

GC167

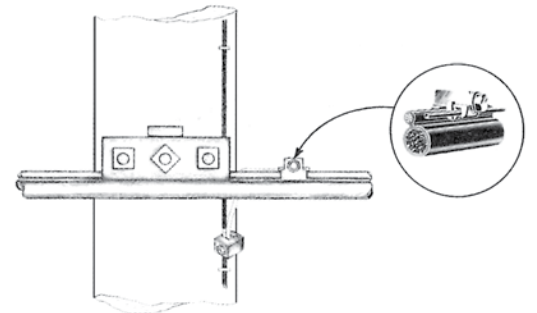

Product Data & Conductor Size

CATALOG NUMBER	DIAMETER		APPROX. DIMENSIONS INCHES					
	MESSENGER (MM)	GROUND TAP (MM)	A (MM)	B (MM)	C (MM)	BOLT		WT LB (KG)
						DIA.	WRENCH	
GC167	.146" - .312" (3.71-7.94)	.146" - .312" (3.71-7.94)	1-5/8 (41.36)	1-1/4 (31.81)	1 (25.45)	5/16 (7.95)	9/16 (14)	.21 (.10)
GC167P								

*Suffix P – Tin-Plated Bronze

DD
4

GENERAL USE - GROUNDING AND BONDING VISE TYPE BRONZE

For Bonding Ribbon, Braid and Tape

Bonding ribbon or braid to bonding ribbon, braid, conductor, or bus and tape to messenger.

Product Data & Conductor Size

CATALOG NUMBER	BONDING RIBBON OR BRAID		APPROX. DIMENSIONS INCHES					WT LB (KG)
	CONNECT	TO	A (MM)	B (MM)	C (MM)	BOLT		
						DIA.	WRENCH	
GC164	Ribbon	Ribbon, Braid, #6	1	5/8	1	1/4	3/8	.12
GC164P†	or Braid	or Bus	(25.45)	(15.90)	(25.45)	(6.36)	(10)	(.05)

† Plated Bronze

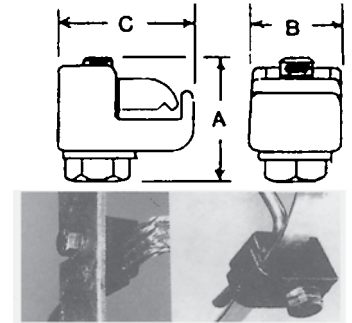

GC164

For Ground Rods

Product Data & Conductor Size

CATALOG NUMBER	RANGE		APPROX. DIMENSIONS INCHES					WT LB (KG)
	ROD DIA. INCHES (MM)	CONDUCTOR	A (MM)	B (MM)	C (MM)	BOLT		
						DIA.	WRENCH	
GC268†	1/4 - 5/8 (6.36-15.90)	6-1/0	2 (50.80)	1 (25.45)	1-3/8 (35.00)	3/8 (9.54)	9/16 (14)	.43 (.19)

* Torque head bolts available for tamperproof, removeable connection.

† Complies with UL-467 and ETL listed

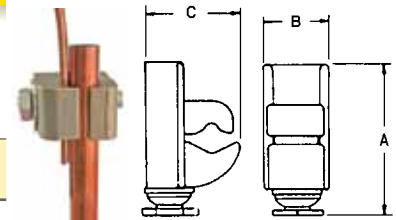

GC268

For Lashing Wire

Connect small diameter lashing wires to messengers.

Product Data & Conductor Size

CATALOG NUMBER	MESSENGER DIAMETER RANGE	LASHING WIRE	APPROX. DIMENSIONS INCHES					WT LB (KG)
	CONNECT (MM)		TO	A (MM)	B (MM)	C (MM)	BOLT	
		DIA.					WRENCH	
GC166	.245" - .500"	All Sizes	1-1/2	7/8	1	1/4	3/8	.16
GC166P	(6.23-12.73)		(38.18)	(22.26)	(25.45)	(6.36)	(10)	(.07)

Suffix P- Plated Bronze

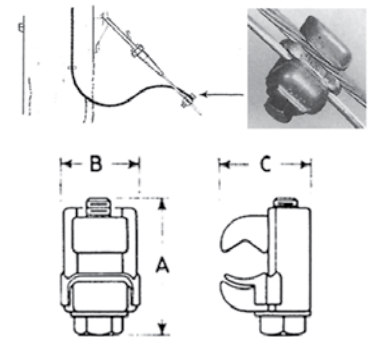

GC166

For Guy Strand

Aluminum bodied connectors for connecting galvanized or aluminum clad strand to copper conductors. Vise Type Parallel Connector.

Product Data & Conductor Size

CATALOG NUMBER	STRAND RANGE (IN.) (MM)	CONDUCTOR RANGE	APPROX. DIMENSIONS INCHES			WT LB (KG)
			A (MM)	B (MM)	C (MM)	
GA9003L**	1/4 (6.36)	4-8	7/8 (22.26)	1-1/4 (31.81)	1-3/4 (44.54)	.17 (.08)
GA9002L**	1/4 - 3/8 (6.36-9.54)	4-8	1-1/8 (28.63)	1-7/8 (47.72)	2-1/8 (54.08)	.23 (.10)
PARALLEL GROOVE TYPE						
LC52AXB**	1/4 - 3/8	2/0 - 8	2-3/8	1-5/8	1-3/8	.20
LC522AXB**	(6.36-9.54)		(60.44)	(41.36)	(35.00)	(.09)

* Inhibitor Protected and Individually Packaged - Standard

† Bimetallic Liner on Tap Side - Copper

**RUS Listed

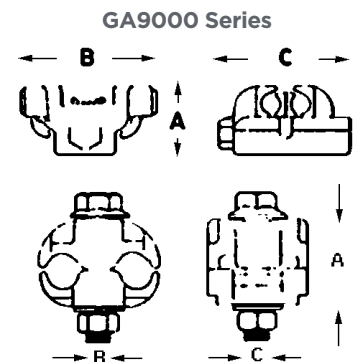

LC50 Series



BRONZE GROUNDING CONNECTOR WIRE TO ROD OR PIPE

BRONZE
GC / C203

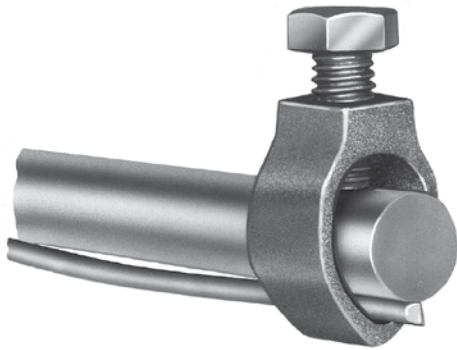

Bronze alloy ground clamp for grounding copper cable parallel to a ground rod or tube.

- Suitable for Direct Burial

Material: **GC-Casting** - Bronze Alloy
Hardware - Stainless Steel
C203-Casting - Galvanized Steel
Hardware - Zinc Plated

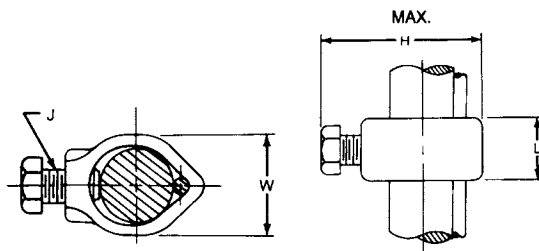

DD
6

Product Data & Conductor Size

CATALOG NUMBER	COPPER CABLE RANGE	ROD DIA.	DIMENSIONS INCHES (MM)				APPROX. WT. EACH LBS. (KG)
			L	H	W	J	
GC4	#8 Sol.—#4 Str.	1/2	5/8 (15.88)	1-7/8 (47.62)	13/16 (20.64)	3/8 (9.52)	.09 (.04)
GC5G5	#10 Sol.—#2 Str.	5/8	5/8 (15.88)	1-19/32 (40.39)	29/32 (23.11)	3/8 (9.52)	.11 (.05)
GC6	#8 Sol.—#4 Str.	3/4	3/4 (19.05)	2-1/8 (53.98)	1-1/32 (26.19)	3/8 (9.52)	.13 (.06)
C2030344 Heavy Duty	#8 Sol.—2/0 Str.	5/8	1-1/8 (28.6)	2-7/8 (73.0)	1-15/32 (37.3)	1/2 (12.7)	.34 (15)
C2030345 Heavy Duty	#8 Sol.—2/0 Str.	3/4	1-1/8 (28.6)	2-7/8 (73.0)	1-15/32 (37.3)	1/2 (12.7)	.30 (.14)

GENERAL USE – BRONZE VISE TYPE GROUND CLAMP LIGHTNING ARRESTER GROUND

BRONZE
GC200 SERIES

- For grounding applications conductor to conductor or plate to conductor
- Provided with standard 1/2-13 threaded studs and flat surfaces for easy one wrench installation

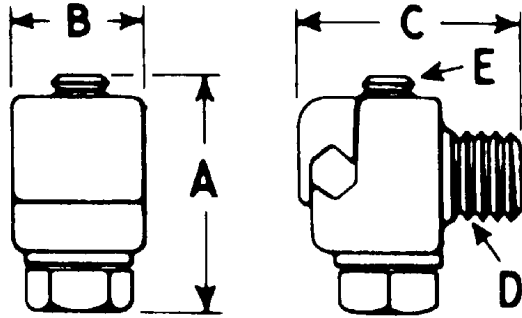

GC207-GC209

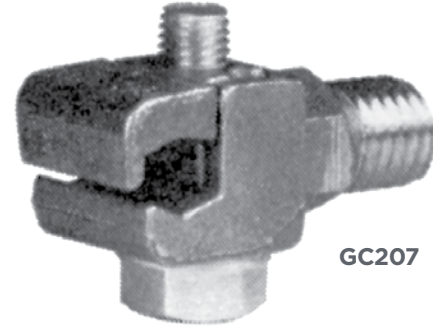

GC207

FIGURE 1 TYPE

- Note: Lightning Arrester type installations, see DC-9.

Material: Body - Copper Alloy
Hardware - Stainless Steel

Product Data & Conductor Size

BRONZE GROUNDING CONNECTOR

CATALOG NUMBER	CONDUCTOR RANGE	APPROX. DIMENSIONS INCHES (MM)					WT LB (KG)
		A	B	C	D	E	
GC207** (Fig. 1)	6 Sol. To 1/0 Str.	1-1/4 (31.81)	3/4 (19.09)	1-7/8 (47.72)	1/2 (12.73)	5/16 (7.95)	.21 (.10)
GC208+ (Fig. 1)	4 Str. To 2/0 Str.	1-5/16 (33.40)	13/16 (20.68)	1-7/8 (47.72)	1/2 (12.73)	5/16 (7.95)	.29 (.13)
GC209**+ (Fig. 1)	3 Sol. To 4/0 Str.	1-1/2 (38.18)	1-1/8 (28.63)	1-3/4 (44.54)	1/2 (12.73)	5/16 (7.95)	.40 (.18)

*GC209 is furnished with bronze jam nut on stud.

+Add Suffix "P" for Tin-plated Version (Minimum purchase quantities may apply)

**RUS Listed

Provides a permanent vibration proof connection. The large flat surface of the male casting provides secure mounting, while the "V" shaped conductor groove assures alignment of grounding connector.



BRONZE GROUND CLAMP CONDUCTOR TO TRANSFORMER TANK TYPE GTCL: 90° GROUND CONDUCTOR MOUNT

BRONZE
GTCL

- Bronze alloy ground clamp for tapping copper conductor to transformer tank
- Tapered threads at base of stud ensure positive locking and electrical contact without lockwashers

Material: **Casting** - Bronze alloy
Eyebolt - Bronze alloy
Hardware - Silicon Bronze alloy or Stainless Steel

Add suffix "TP" for tin-plated version.

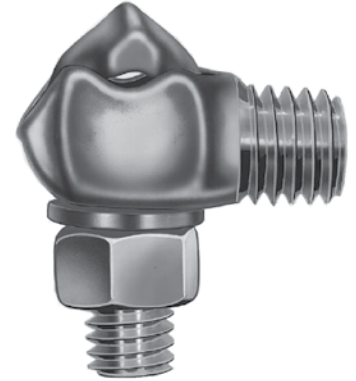
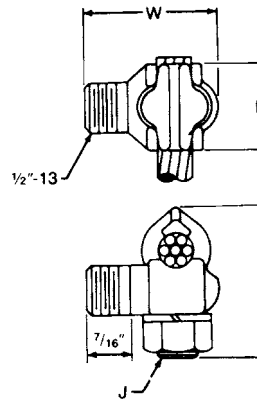

Product Data & Conductor Size

CATALOG NUMBER	COPPER CABLE RANGE	APPROX. DIMENSIONS INCHES (MM)				APPROX. WT. EACH LBS. (KG)
		L	H	W	J	
GTCL23A*	#10 Sol. - #1 Str.	7/8 (22.22)	1-1/2 (38.1)	1-3/8 (34.92)	3/8 (9.52)	.20 (.09)
GTCL34A*	#8 Sol. - 2/0 Str.	1 (25.4)	1-7/8 (47.62)	1-17/32 (38.89)	3/8 (9.52)	.25 (.11)

*RUS Listed

GROUND CLAMP CONDUCTOR TO TRANSFORMER TANK TYPE GTCS: 90° OR STRAIGHT GROUND MOUNT

BRONZE
GTCS

- Bronze alloy ground clamp for tapping copper conductor to transformer tank
- Tapered thread at base of stud ensures positive locking and electrical contact without lockwashers. Hex wrenching surface above tapered thread provides easy installation.

Material: **Casting** - Bronze alloy
Eyebolt - Bronze alloy
Hardware - Silicon Bronze alloy or Stainless Steel

Add suffix "TP" for tin-plated version.

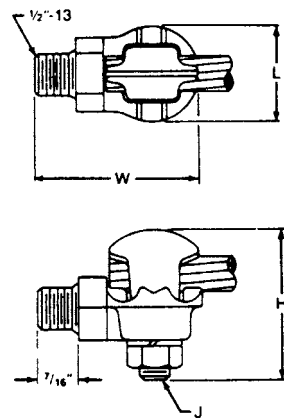

Product Data & Conductor Size

CATALOG NUMBER	COPPER CABLE RANGE	APPROX. DIMENSIONS INCHES (MM)				APPROX. WT. EACH LBS. (KG)
		L	H	W	J	
GTCS21	#10 Sol. - #1 Str.	1-1/8 (28.58)	1-5/8 (41.28)	1-7/8 (47.62)	3/8 (9.52)	.29 (.13)
GTCS34A	#8 Sol. - 2/0 Str.	1-1/4 (31.75)	1-7/8 (47.62)	2-1/4 (57.27)	3/8 (9.52)	.34 (.15)
GTCS41	#6 Sol.—250 MCM	1-5/8 (41.28)	2-3/8 (60.32)	2-1/2 (63.5)	1/2 (12.7)	.45 (.20)



BRONZE GROUNDING POST CONNECTOR TYPES KS & K2S

BRONZE
KS / K2S



**FIGURE 1
TYPE KS
FOR ONE WIRE**



**FIGURE 2
TYPE K2S
FOR TWO WIRES**

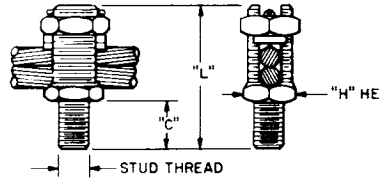
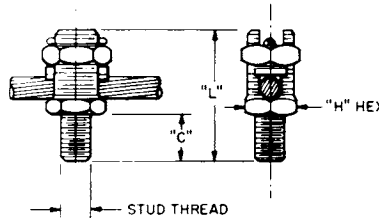

- For copper to copper conductor connections. One or two copper conductors to steel structure or transformer for grounding. Also useful as a bar tap for cable to bus bar.

Material: Copper Alloy

486A
467



LISTED
261L

DD
9

Product Data & Conductor Size

CATALOG NUMBER	FIGURE NUMBER	CONDUCTORS - AWG		STUD THREAD	DIMENSIONS INCHES (MM)			APPROX. WT. EACH LBS. (KG)
		STRANDED	SOLID		C	H	L	
KS6	1	#10-#7	#10-#6	1/4-20	1/2 (12.7)	7/16 (11.1)	1-5/16 (33.34)	.06 (.027)
K2S6	2	#10-#7	#10-#6	1/4-20	1/2 (12.7)	7/16 (11.1)	1-15/32 (37.30)	.07 (.032)
KS4	1	#10-#5	#10-#4	5/16-18	9/16 (14.29)	1/2 (12.7)	1-1/2 (38.10)	.08 (.036)
K2S4	2	#10-#5	#10-#4	5/16-18	9/16 (14.29)	1/2 (12.7)	1-22/32 (43.63)	.09 (.041)
KS2	1	#10-#3	#10-#2	3/8-16	5/8 (15.88)	9/16 (14.29)	1-19/32 (40.46)	.12 (.055)
K2S2	2	#10-#3	#10-#2	3/8-16	5/8 (15.88)	9/16 (14.29)	1-7/8 (47.63)	.13 (.059)
KS1	1	#8-#2	#8-#1	3/8-16	5/8 (15.88)	5/8 (15.88)	1-3/4 (44.45)	.13 (.059)
K2S1	2	#8-#2	#8-#1	3/8-16	5/8 (15.88)	5/8 (15.88)	2 (50.80)	.15 (.068)
KS10	1	#2-1/0	#2-1/0	1/2-13	3/4 (19.05)	3/4 (19.05)	2-1/16 (52.40)	.18 (.082)
K2S10	2	#2-1/0	#2-1/0	1/2-13	3/4 (19.05)	3/4 (19.05)	2-7/16 (61.91)	.20 (.091)
KS20	1	#2-2/0	#2-2/0	1/2-13	3/4 (19.05)	7/8 (22.23)	2-3/16 (55.57)	.26 (.118)
K2S20	2	#2-2/0	#2-2/0	1/2-13	3/4 (19.05)	7/8 (22.23)	2-9/16 (65.09)	.29 (.132)
KS40	1	#1-4/0	#1-4/0	5/8-11	1 (25.4)	1-1/8 (28.58)	2-5/8 (66.68)	.55 (.25)
K2S40	2	#1-4/0	#1-4/0	5/8-11	1 (25.4)	1-1/8 (28.58)	3-1/8 (79.38)	.59 (.27)
KS500	1	3/0-500	—	3/4-10	1-1/4 (31.75)	1-5/8 (41.28)	3-5/8 (92.09)	1.30 (.591)
K2S500	2	3/0-500	—	3/4-10	1-1/4 (31.75)	1-5/8 (41.28)	4-1/2 (114.30)	1.32 (.60)



LIGHTNING ARRESTER GROUNDING TERMINALS TYPE LAT AND GC207LA BRONZE DISTRIBUTION ARRESTER TERMINALS (See also Page DC9 - DC10)

BRONZE
LAT, GC207LA

- This versatile bronze connector can be mounted to a drilled plate, structure or bar using a 3/8"-16 cap screw. It can also be screwed onto a 3/8"-16 bushing stud and secured in place with the included jam nut. The eyebolt can be positioned within the body to allow either vertical or horizontal conductor entrances.

Material: **Casting** - Bronze alloy
Eyebolt - Bronze alloy
Hardware - Silicon Bronze alloy
 - Brass jam nut

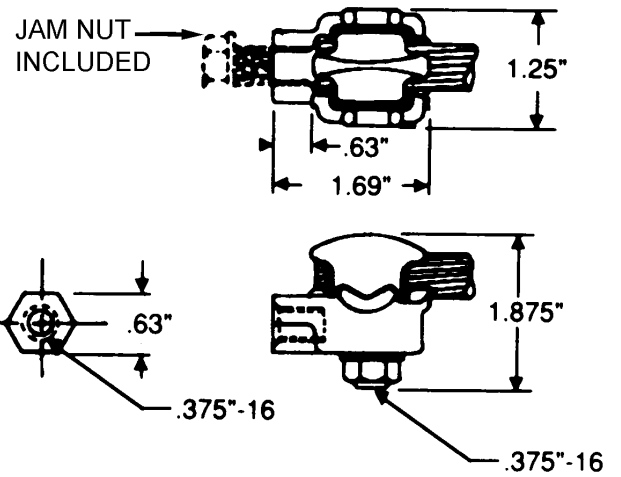

Product Data & Conductor Size

CATALOG NUMBER	STUD SIZE	CONDUCTOR RANGE O.D.	LENGTH INCHES (MM)	APPROX. WT. EACH LBS. (KG)
LAT20	3/8" - 16	8 Sol. - 2/0 Str. .12" - .42" O.D.	1.69 (43)	40 (18)

Add suffix "TP" for tin-plated connector

- This connector is intended primarily for bottom termination of lightning arresters to ground. May also be employed on top connections.

Material: **Casting** - Bronze alloy
Eyebolt - Bronze alloy
Hardware - Stainless Steel

NOTE: See pages DC-9 - DC-10 for application details.

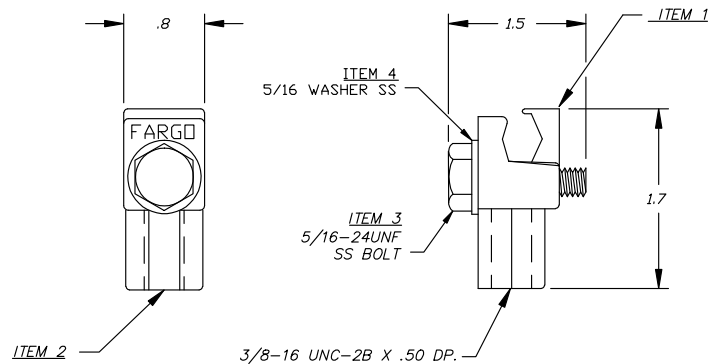

CONDUCTOR RANGE:
6 SOL. - 1/0 STR.



Product Data & Conductor Size

CATALOG NUMBER	STUD SIZE	CONDUCTOR RANGE O.D.	APPROX. WT. 100 LBS. (KG)
GC207LA	3/8" - 16	#6 Sol. - 1/0 Str. .162" - .373" (4.1 - 9.5) mm	22 (9.9)

Add suffix "P" for tin-plated connector

DD 10



TYPE APD ARC PROTECTION FOR COVERED PRIMARY CONDUCTOR

ALUMINUM
APD

- The APD helps prevent lightning induced burndowns of covered overhead aluminum primary conductors and allows users to comply with Article 276 of the National Electric Safety Code, 1981 Edition.
- The device protects covered conductor by shielding it from the usual concentration of arc energy generated during a lightning strike. Without the device, such arcs can puncture the conductor cover and ground to the neutral leaving a short section of conductor strands that are either completely destroyed or badly eroded and seriously weakened. (Conventional overcurrent protection equipment does not operate fast enough to protect these lightning exposed conductors.) APD lightning protectors add mass of the correct shape to the conductor in the area where it absorbs the terminus of arc energy. It is thus a partially sacrificed component during each strike yet retains enough of its original mass and configuration to accommodate several strikes without losing effectiveness or allowing the adjacent line insulator to be splattered with damaging metallic particles.
- APD lightning protectors are both laboratory tested and field proven with the same successful results. They are offered in two models. The high energy APD-80 model is designed to withstand multiple operations at 21,000 amperes fault current for ten (10) cycles without conductor damage. A low-energy APD-57 model is available for applications where fuses limit the destructive energy by clearing the fault more rapidly than circuit breakers.

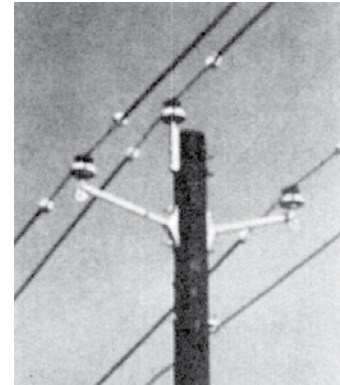

Three Phase Pole Top with APD Lightning Protectors in Place. (Only one unit is required on the load side of the line at each support for a radial circuit)

Material: Castings—Aluminum Alloy
Hardware—APD57—Galvanized Steel
APD80—Stainless Steel

Note: A radial circuit requires an APD protector on the load side of the insulator only, while other circuit configurations, such as loops, require that they be installed on both sides of the line insulator. In both situations, they must be installed on all conductor phases and positioned outside the end of a tie wire. The covering must be stripped away over this distance including the area within the confines of a tie wire. Since an arc from one phase to the neutral will often expand to fault all three phases, the device must be installed on all three phases.

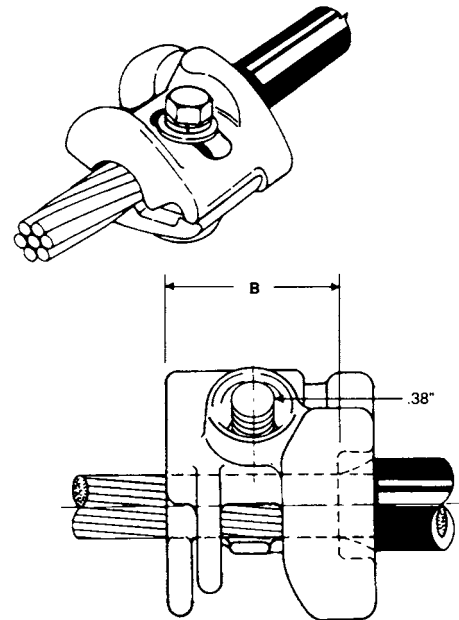

Product Data & Conductor Size

CATALOG NUMBER (WITH INHIBITOR)	MAX. O.D. OF CABLE JACKET—INCHES	CONDUCTOR RANGE O.D. IN INCHES	DIMENSION B—INCHES (MM)	APPROX. WT. 100 LBS. (KG)
(1) APD57XB (Fused circuits)	0.906	#1-4/0 STR. AAC #2-4/0 ACSR 0.31-0.57	1.06 (27)	24 (11)
APD80XB	1.200	2/0-556.5 Str. AAC 1/0-477 (18/1) ACSR 0.39-0.86	1.87 (48)	66 (30)

(1) This item is suitable for use on fused circuits only. Specifically, it should not be installed on lines protected by circuit breakers because of their relatively slow interrupting rate.



TINNED ALUMINUM OR BRONZE TRANSFORMER SPADE TERMINALS TYPE AXS & BXS

BRONZE	ALUMINUM
BXS	AXS



- Secured by jam nut to bushing stud.
- Recommended when copper terminals are connected (Use "AXS" style for aluminum terminals.)
- Terminal lug mounting holes are 9/16" diameter with 1-3/4" NEMA spacing. Jam nuts are usually supplied by the transformer manufacturer and are not furnished unless specified.

Material: Castings - **BXS** - Bronze alloy (tin-plated)
AXS - Aluminum alloy (tin-plated)

- Notes:** (1) Terminals for 1-1/4" - 12 bushing studs can be furnished with a 1/4" - 20 tapped hole in the outer end to attach an insulated suspension support rod for mechanical support. Add suffix "-MS" for this option.
(2) Add suffix "JN" to specify a factory applied brass jam nut.

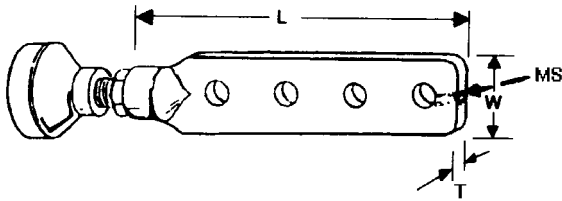

DD
12

Product Data & Conductor Size

CATALOG NUMBER	X'FORMER STUD SIZE	GENERAL DESCRIPTION & FIELD APPLICATION	DIMENSIONS INCHES (MM)			APPROX. WT. 100 LBS. (KG)
			LENGTH	WIDTH	HEIGHT	
BXS582N	5/8"-11	Two Holes in Line NEMA Spaced For Use With One Hole Lugs	5.12 (130)	1.37 (35)	0.31 (8)	70 (32)
BXS102N	1"-14		5.06 (129)	1.93 (49)	0.34 (9)	142 (64)
BXS584N	5/8"-11	Four Holes in Line NEMA Spaced For Use With One Hole Lugs	8.50 (216)	1.37 (35)	0.31 (8)	120 (54)
BXS104N	1"-14		8.56 (218)	1.93 (49)	0.34 (9)	215 (98)
AXS584NTP	5/8"-11		8.50 (216)	1.37 (35)	0.31 (8)	36 (16)
AXS104NTP	1"-14		8.56 (218)	2.00 (50)	0.34 (9)	65 (29)
BXS582BN	5/8"-11	Two Sets of NEMA Spaced Holes Mounts Up to 4 Two-Holed Lugs	5.37 (136)	3.50 (89)	0.25 (6)	132 (60)
BXS102BN	1"-14		5.87 (149)	3.50 (89)	0.37 (9)	260 (118)
AXS582BNTP	5/8"-11		5.37 (136)	3.50 (89)	0.25 (6)	39 (18)
BXS583BN	5/8"-11	Three Sets of NEMA Spaced Holes Mounts Up to 6 Two-Holed Lugs	6.62 (168)	3.50 (89)	0.37 (9)	256 (116)
BXS103BN	1"-14		7.00 (178)	3.50 (89)	0.37 (9)	315 (143)
AXS103BNTP	1"-14		7.00 (178)	3.50 (89)	0.37 (9)	94 (43)
BXS584BN	5/8"-11	Four Sets of NEMA Spaced Holes Mounts Up to 8 Two-Holed Lugs	8.37 (213)	3.50 (89)	0.37 (9)	330 (150)
BXS104BN	1"-14		8.75 (222)	3.50 (89)	0.37 (9)	362 (164)
BXS123BN	1-1/4"-12	Three Sets of NEMA Spaced Holes Mounts Up to 6 Two-Holed Lugs Or Up to 12 Two-Holed Lugs If Stacked	7.12 (181)	3.50 (89)	0.37 (9)	345 (156)
BXS124BN	1-1/4"-12	Four Sets of NEMA Spaced Holes Mounts Up to 8 Two-Holed Lugs Or Up to 16 Two-Holed Lugs If Stacked	9.12 (232)	3.50 (89)	0.37 (9)	445 (202)
BXS126BN	1-1/4"-12	Six Sets of NEMA Spaced Holes Mounts Up to 12 Two-Holed Lugs Or Up to 24 Two-Holed Lugs If Stacked	14.00 (356)	4.00 (102)	0.50 (13)	970 (440)
BXS128BN	1-1/4"-12	Eight Sets of NEMA Spaced Holes Mounts Up to 16 Two-Holed Lugs Or Up to 32 Two-Holed Lugs If Stacked	17.50 (445)	4.00 (102)	0.50 (13)	1300 (590)

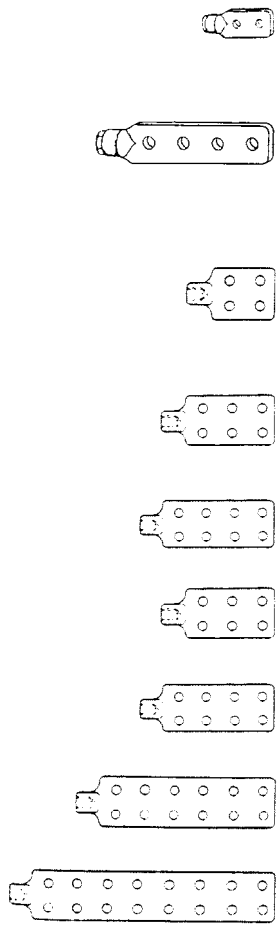



GENERAL USE PARALLEL GROOVE ALUMINUM MULTI-TAP STREET LIGHT CONNECTOR

ALUMINUM
GO32

For: Aluminum to copper or Aluminum conductor

Application

The Fargo GO32 Multiple Tap Connector is designed for making street light connections in the limited space provided in tubular street light poles.

Description

- High strength, extruded aluminum alloy.
- Permanent contact pressure provided by use of high strength steel bolt and stainless steel Belleville washer.
- Run conductor can be “looped” through the connector eliminating the need to cut the conductor.
- Compact design allows use in even the smallest “handholes” provided in street light poles or bases.
- Optional slip-over Platisol boot (Catalog No. GO32B) is available for insulating the phase conductor. Inhibitor loading furnished standard.

Material: **Body** – Aluminum Alloy
Hardware – Stainless Steel

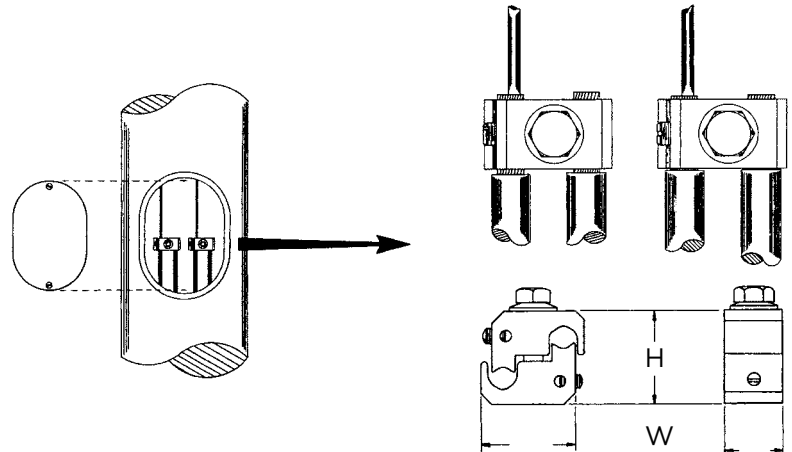

MULTIPLE STREET LIGHT TAP CONNECTOR

DD
13

Product Data & Conductor Size

CATALOG NUMBER	CONDUCTOR RANGE*		DIMENSIONS INCHES (MM)			WT LB (KG)	INSULATING COVER
	RUN	TAP	L	W	H		
GO32	#6-1/0	#12-#8	1.25 (31.81)	0.75 (19.09)	1.50 (38.18)	.09 (.04)	GO32B**

* GO32 will accept two (2) #6 sol. through 1/0 aluminum run conductors, as well as two (2) #12 through #8 AL/CU tap conductors.

** Order GO32K to receive connector and cover as a kit.



OVERHEAD TRANSFORMER PAD ADAPTER CONNECTORS TIN-PLATED BRONZE FLAG ADAPTERS USE W/EYEBOLT (GTCL/GTCS) TYPE SECONDARY BUSHING TERMINALS

BRONZE
VF

- Bronze terminal adapter for connecting a flat pad to NEMA secondary transformer terminal
- Optional for use with Type GTCL or GTCS terminals.

Material: Castings - Bronze alloy - tin-plated

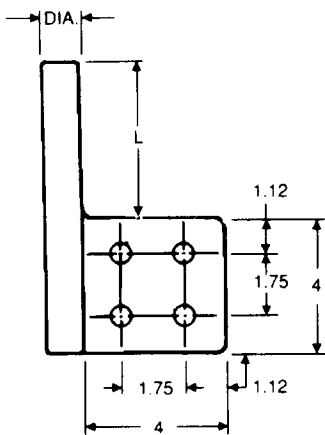
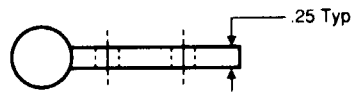

VF4

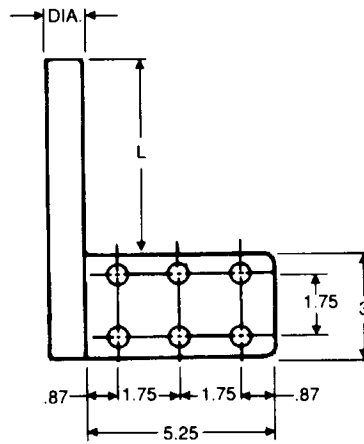

VF6

Product Data & Conductor Size

CATALOG NUMBER	NEMA DRILLED PAD & ROD DESCRIPTION	TRANSFORMER SIZE RATING (SINGLE PHASE)	DIMENSIONS INCHES (MM)		APPROX. WT. 100 LBS. (KG)
			L	DIA.	
VF440	4 Hole 4" x 4" x 1/4" Pad	5-15 KVA	2.25	.50	165 (75)
VF640	6 Hole 3" x 5-1/4" x 1/4" Pad		(57)	(13)	180 (82)
VF4350	4 Hole 4" x 4" x 1/4" Pad	25-50 KVA	2.75	.75	216 (98)
VF6350	6 Hole 3" x 5-1/4" x 1/4" Pad		(70)	(20)	231 (105)
VF4500	4 Hole 4" x 4" x 1/4" Pad	75 KVA	4.00	.81	245 (111)
VF6500	6 Hole 3" x 5-1/4" x 1/4" Pad		(102)	(21)	260 (118)
VF41000	4 Hole 4" x 4" x 1/4" Pad	100 KVA	4.00	1.00	312 (142)
VF61000	6 Hole 3" x 5-1/4" x 1/4" Pad		(102)	(25)	327 (148)

DD
14



SET SCREW BAR TRANSFORMER CONNECTORS TOGGLE LATCH

ALUMINUM
UTSB

For connecting secondary underground applications to transformer studs.

Innovative "Toggle Latch" mechanism provides unmatched ease of installation, along with superior electrical performance.

One part accepts both 5/8"-11 and 1"-14 threads.

Oxide Inhibiting Compound provided as standard in stud and tap holes.

5/16" allen set screws provide constant pressure on conductors.

Testing meets or exceeds ANSI C119.6 Class "A" tests.

Redundant ground ports provided for use on neutral phase connections.

Toggle nut is 3/4" across flats, fits standard GP223 Speed Wrench.

Material: **Body** — Aluminum Alloy
Hardware — High Strength Steel
Boot/Cover — Poly-vinyl chloride (PVC)

Note: Not suitable for submersible installations.

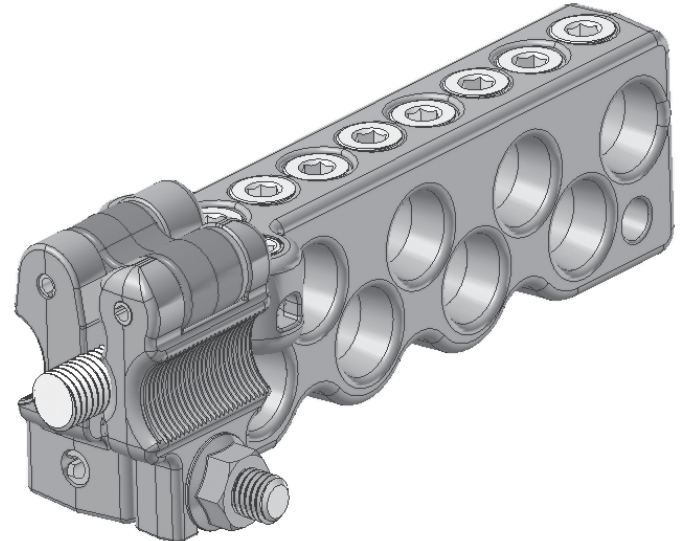

DD
15

Product Data & Conductor Size

CATALOG NUMBER	TRANSFORMER STUD SIZES	CONDUCTOR RANGE			MAIN PORTS	STREET LIGHT PORTS	GROUND PORTS	PACKAGING PER BOX	
		MAIN PORTS	STREET LIGHT PORT	REDUNDANT GROUND				UNITS	WEIGHT (LBS)
UTSB8500L	5/8"-11 & 1"-14"	#6 SOL - 500 MCM	#12 SOL - 1/0 SOL	#12 SOL - #2 SOL	8	1	2	12	36
		0.162" - 0.813"	0.081" - 0.325"	0.081" - 0.258"					

NOTE: Add suffix "C" for clear PVC cover included in package "UTSB8500CL. Factory applied inhibitor (HTJC) included standard. Cover Part Number: CTL8500

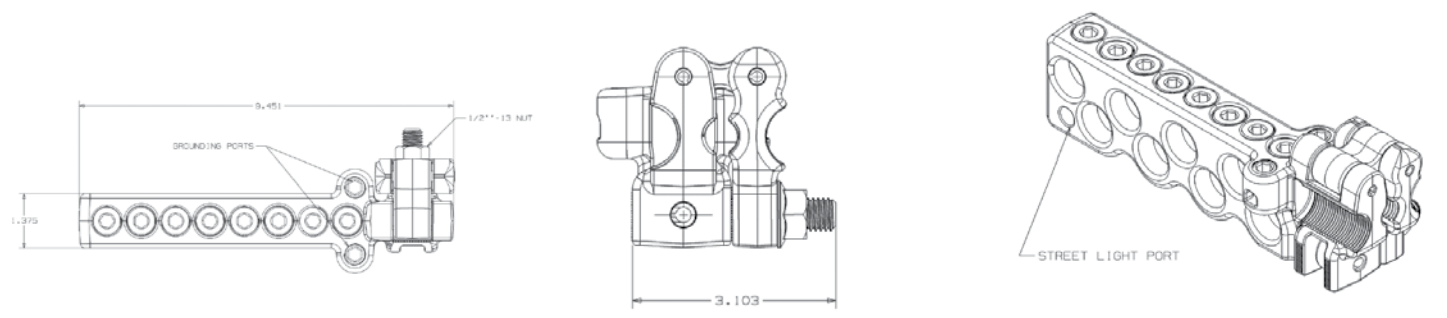



SET SCREW BAR TRANSFORMER CONNECTORS TOGGLE LATCH

ALUMINUM
UTZB

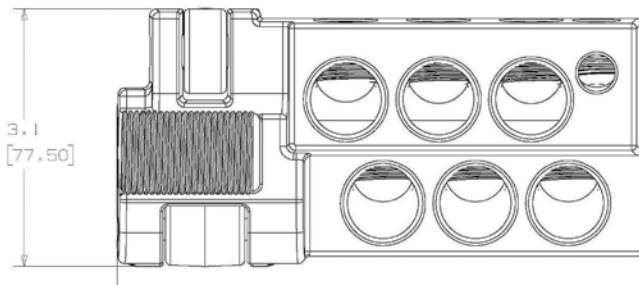
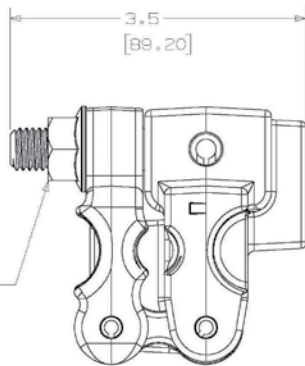
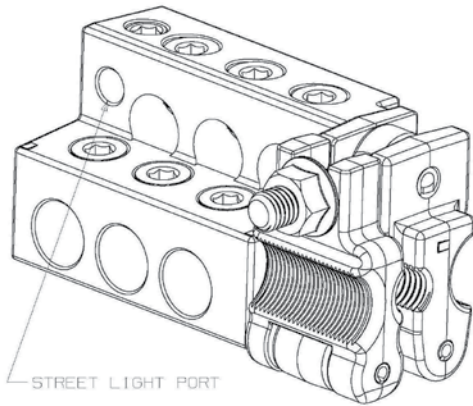
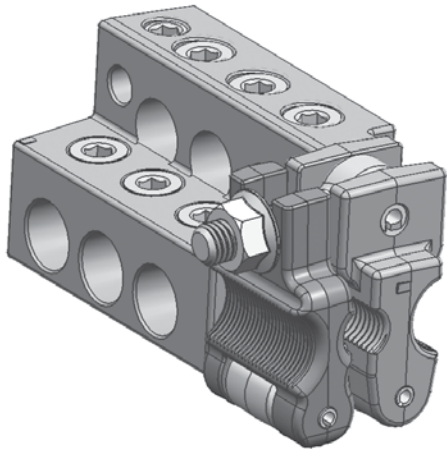

Units are expressed in inches (millimeters)

For connecting secondary underground applications to transformer studs.

Innovative "Toggle Latch" mechanism provides unmatched ease of installation, along with superior electrical performance.

Reduced inventory; one part accepts both 5/8"-11 and 1"-14 thread transformer studs.

Oxide Inhibiting Compound provided as part of standard in stud and tap holes.

Allen head set screws (fits 5/16" allen wrench) provide constant pressure on conductors.

Meets or exceeds ANSI C119.6 Class "A" tests.

Toggle nut is 3/4" across flats, fits standard GP223 Speed Wrench.

Material: Body — Aluminum Alloy
Set Screws — Aluminum Alloy
Hardware — High Strength Steel
Boot/Cover — Poly-vinyl chloride (PVC)

Note: Not suitable for submersible installations.

Product Data & Conductor Size

CATALOG NUMBER	TRANSFORMER STUD SIZES	CONDUCTOR RANGE			MAIN PORTS	STREET LIGHT PORTS	GROUND PORTS	PACKAGING PER BOX	
		MAIN PORTS	STREET LIGHT PORT	REDUNDANT GROUND				UNITS	WEIGHT (LBS)
UTZB6500L	5/8"-11 & 1"-14"	#6 SOL - 500 MCM	#12 SOL - 1/0 SOL	#12 SOL - #2 SOL	6	1	2	12	32
		0.162" - 0.813"	0.081" - 0.325"	0.081" - 0.258"					

NOTE: Add suffix "C" for kit with stud bar & clear PVC cover (UTZB6500CL). Factory applied inhibitor (HTJC) included standard.
Cover Part Number: CZTL6500

DD
16



GENERAL USE VISE TYPE PARALLEL GROOVE BRONZE

BRONZE
GC8000

- For copper to copper conductor -splice, loop deadend or service entrance taps

Material: **Castings** - Copper Alloy
Hardware - Stainless Steel
 Galvanized Steel
 Silicon Bronze

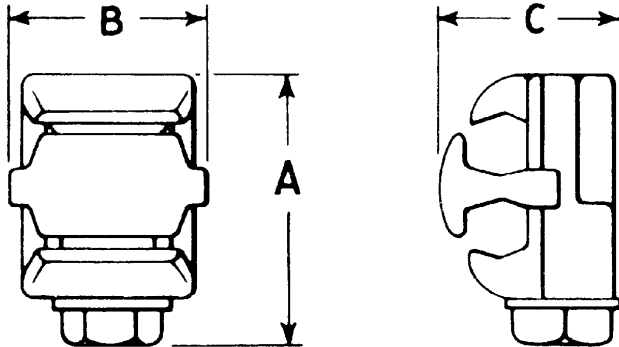
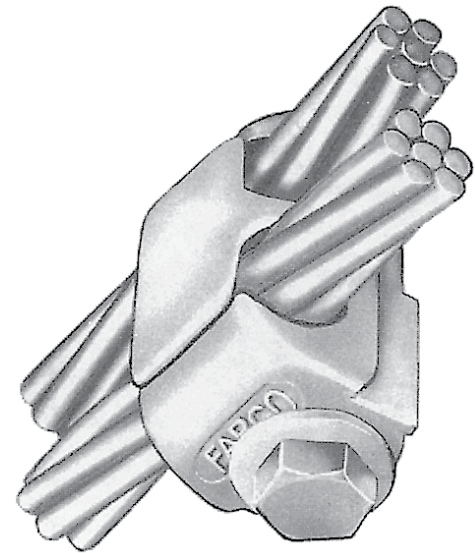

DD
17

Suffix Construction:

“G” = Grommets - holds spacer during OH installs
 “L” = Inhibitor Applied @ Factory

Product Data & Conductor Size

CATALOG NUMBER	*CONDUCTOR RANGE (AWG)			APPROX. DIMENSIONS INCHES			BOLT SIZE	BOLT HEAD (HEX)	WT. LBS. (KG)
	MAIN		MIN. SOL.	A (MM)	B (MM)	C (MM)			
	SOL.	STR.							
GC8002	2	3	8	1 3/8 (34.99)	1 1/4 (31.81)	7/8 (22.27)	5/16 (7.95)	9/16 (14.32)	.16 (.07)
GC8010	1/0	1	8	1 1/2 (38.18)	1 3/8 (34.99)	1 (25.45)	5/16 (7.95)	9/16 (14.32)	.24 (.11)
GC8020	3/0	2/0	8	1 3/4 (44.54)	1 3/8 (34.99)	1 1/8 (28.63)	5/16 (7.95)	9/16 (14.32)	.33 (.15)
GC8040**	4/0	4/0	6	2 3/8 (60.44)	1 1/2 (38.18)	1 1/2 (38.18)	3/8 (9.54)	9/16 (14.32)	.62 (.28)

*For Tin-plated Connectors add Suffix “P” to the Catalog Number desired.
 **RUS Listed

Conductor Range

Each size will close on two of the maximum size conductors, one minimum and one maximum size, or combinations in between.

Hot Stick Installation

All connectors are available with flexible neoprene grommets to hold spacer bar in position so run and tap connectors may be installed with ease. Grommets positioning spacer do not interfere with smooth operation of connector. If clamps are to be equipped with grommets, please specify by adding suffix “G” to the catalog number.

Inhibitor Protected and Bagged

Connectors are available with Factory installed Fargolene inhibitor and individually packaged. When ordering add the Suffix “L” to catalog number.



GENERAL USE PARALLEL GROOVE ALUMINUM MULTIPLE U-BOLTS WITH COPPER LINER

ALUMINUM
LCC

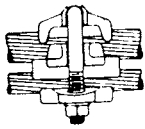
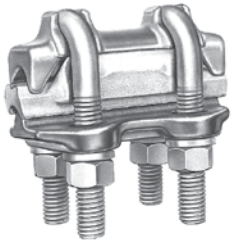

FIGURE 1

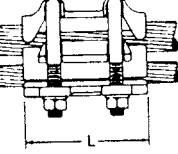
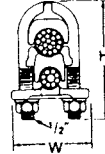

FIGURE 2

For aluminum to copper conductor connections only. Sealant (XB) is recommended on all connections

Material: **Body**—Top member 356-T6 Aluminum Alloy
Spacer—Aluminum Alloy with a metallurgically bonded Copper liner
Bottom Member—High Strength Bronze
Hardware—Galvanized Steel

Product Data & Conductor Size

CATALOG NUMBER	FIGURE NUMBER	CONDUCTOR RANGE		DIMENSIONS INCHES (MM)			APPROX. WT. EACH LBS. (KG)
		MAIN	TAP	L	W	H	
LCC111XB	1	#6 Sol.—2/0 Str. AAC #8 Sol.—2/0 (6/1) ACSR	#8 Sol.—2/0 Str. CU	2 (50.80)	2-5/16 (58.74)	3-1/2 (88.90)	.77 (.35)
LCC221XB	1	1/0 Str.—400 MCM AAC 1/0 (6/1)—397.5 (18/1) ACSR	#4 Sol.—4/0 Str. CU	2-1/2 (63.50)	2-11/16 (68.26)	4 (101.60)	1.11 (.50)
LCC222XB	2	1/0 Str.—400 MCM AAC 1/0 (6/1)—397.5 (18/1) ACSR	#4 Sol.—4/0 Str. CU	3-7/8 (98.43)	2-3/4 (69.85)	4 (101.60)	1.68 (.76)
LCC231XB	1	1/0 Str.—400 MCM AAC 1/0 (6/1)—397.5 (18/1) ACSR	1/0 Str.—500 MCM CU	2-1/2 (63.50)	2-11/16 (68.26)	4 (101.60)	1.24 (.56)
LCC242XB	2	1/0 Str.—400 MCM AAC 1/0 (6/1)—397.5 (18/1) ACSR	400—800 MCM CU	4-1/8 (104.78)	2-11/16 (68.26)	4-1/4 (107.95)	2.10 (.95)
LCC332XB	2	336.4—954 MCM AAC 300—795 MCM ACSR	1/0 Str.—400 MCM CU	4-5/8 (117.48)	3-1/16 (77.79)	4-5/8 (117.48)	2.88 (1.31)

GENERAL USE PARALLEL GROOVE ALUMINUM THREE CENTER BOLTS WITH COPPER LINER

ALUMINUM
LC600

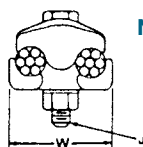
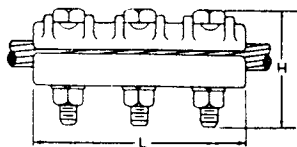
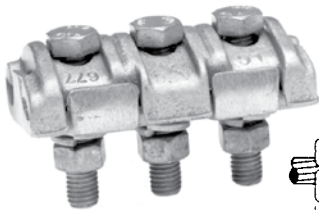

For aluminum to copper conductor connections only. Sealant (XB suffix) is recommended on all connections

Material: **Body**—356-T6 Aluminum Alloy
Hardware—Hot Dip Galvanized Steel
Tap Liner—Copper, Metallurgically Bonded

Product Data & Conductor Size

CATALOG NUMBER	CONDUCTOR RANGE		DIMENSIONS INCHES (MM)				APPROX. WT. EACH LBS. (KG)
	MAIN	TAP	L	W	H	J	
LC677XB	1/0 (19)—336.4 MCM AAC 1/0—300 MCM ACSR	1/0 (7)—250 Str. CU	4-3/8 (111.13)	2-5/16 (58.74)	2-1/2 (63.5)	1/2 (12.7)	1.35 (.61)

DD
18



GENERAL USE - PARALLEL GROOVE - ALUMINUM SINGLE CENTER BOLT

For aluminum to aluminum and aluminum to copper conductor splice/tap connections. Sealant (XB) is recommended on all connections.

Material: **Body**—Aluminum alloy
Hardware—Galvanized steel

- Notes:** 1) For connectors without sealant, delete suffix "XB."
2) Add suffix "GP" for a tin-plated connector.
3) Plastic Cover Available. (See Type PTC Cover)

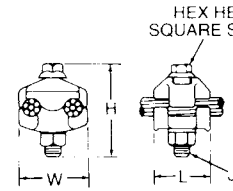
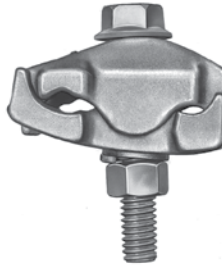

FIGURE 1

ALUMINUM
LC50 & LC80

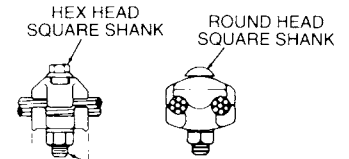

FIGURE 2

Product Data & Conductor Size

CATALOG NUMBER	FIGURE NUMBER	CONDUCTOR RANGE		DIMENSIONS INCHES (MM)				APPROX. WT. EACH LBS. (KG)
		MAIN	TAP	L	W	H	J	
LC51AXB**	1	#8 Sol.—1/0 Str. AAC #8—1/0 ACSR	#8 Sol.—#2 Str. AAC #8—#2 ACSR #8 Sol.—#2 Str. Cu	1-1/8 (28.58)	1-13/32 (35.72)	1-1/2 (38.10)	5/16 (8.0)	.14 (.06)
LC51CXB**	1	#8 Sol.—1/0 Str. AAC #8—1/0 ACSR	#8 Sol.—1/0 Str. AAC #8—1/0 ACSR #8 Sol.—1/0 Str. Cu	1-1/4 (31.76)	1-17/32 (38.89)	2 (50.80)	3/8 (9.53)	.19 (.09)
LC52AXB**	1	#8 Sol.—2/0 Str. AAC #8—2/0 ACSR	#8 Sol.—2/0 Str. AAC #8—2/0 ACSR #8 Sol.—2/0 Str. Cu	1-3/8 (34.93)	1-21/32 (42.07)	2 (50.80)	3/8 (9.53)	.22 (.10)
LC52CXB**	1	#1 Sol.—400 MCM AAC #1—336.4 MCM ACSR	#8 Sol.—2/0 Str. AAC #8—2/0 ACSR #8 Sol.—2/0 Str. Cu	2 (50.80)	2-1/32 (51.60)	2-1/4 (57.15)	3/8 (9.53)	.28 (.13)
LC53AXB**	2	#1 Sol.—400 MCM AAC #1—336.4 MCM ACSR	#1 Sol.—400 MCM AAC #1—336.4 MCM ACSR #1 Sol.—400 MCM Cu	2 (50.80)	2-11/32 (59.53)	2-1/2 (63.50)	1/2 (12.70)	.41 (.19)
LC83AXB**	2	397.5—954 MCM AAC 336.4—795 MCM ACSR	#8 Sol.—2/0 Str. AAC #8—2/0 ACSR #8 Sol.—2/0 Str. Cu	1-1/2 (38.1)	2-17/32 (64.29)	2-3/4 (69.85)	1/2 (12.70)	.54 (.24)

**RUS Listed

GENERAL USE - PARALLEL GROOVE - ALUMINUM SINGLE CENTER BOLT WITH COPPER LINER

For aluminum to copper conductor connections only. Sealant (XB) is recommended on all connections.

Material: **Body**—Aluminum Alloy
Hardware—Galvanized Steel
Tap Liner—Copper metallurgically bonded

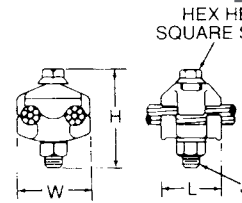

FIGURE 1

ALUMINUM
LC500 & LC800

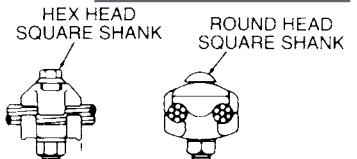

FIGURE 2

Product Data & Conductor Size

CATALOG NUMBER	FIGURE NUMBER	CONDUCTOR RANGE		DIMENSIONS INCHES (MM)				APPROX. WT. EACH LBS. (KG)
		MAIN	TAP	L	W	H	J	
LC511AXB**	1	#6 Sol.—1/0 Str. AAC #8—1/0 ACSR	#8 Sol.—#2 Str. Cu	1-1/8 (28.58)	1-5/16 (33.34)	1-1/2 (38.10)	5/16 (8.0)	.14 (.06)
LC522AXB**	1	#6 Sol.—1/0 Str. AAC #8—1/0 ACSR	#8 Sol.—1/0 Str. Cu	1-3/8 (34.93)	1-21/32 (42.07)	2 (50.80)	3/8 (9.53)	.22 (.10)
LC542XB	1	#6 Sol.—1/0 Str. AAC #8—1/0 ACSR	1/0 Str.—4/0 Str. Cu	1-3/16 (30.16)	1-25/32 (45.24)	2 (50.80)	3/8 (9.53)	.24 (.11)
LC811AXB**	1	#1 Sol.—400 MCM AAC #1—336.4 MCM ACSR	#8 Sol.—1/0 Str. Cu	1-1/4 (31.75)	2-1/32 (51.59)	2-1/4 (57.15)	3/8 (9.53)	.29 (.13)
LC822XB	2	#1 Sol.—400 MCM AAC #1—336.4 MCM ACSR	#8 Sol.—2/0 Str. Cu	2-1/4 (57.15)	2-7/32 (56.36)	2-1/2 (63.50)	1/2 (12.70)	.46 (.21)
LC833XB**	2	397.5—954 MCM AAC 336.4—795 MCM ACSR	#8 Sol.—2/0 Str. Cu	2-1/2 (63.50)	2-17/32 (64.29)	2-3/4 (69.85)	1/2 (12.70)	.54 (.24)

**RUS Listed



GENERAL USE PARALLEL GROOVE - ALUMINUM MULTIPLE CENTER BOLTS

ALUMINUM
LC60 / GA600

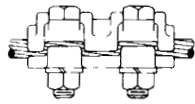

FIGURE 1

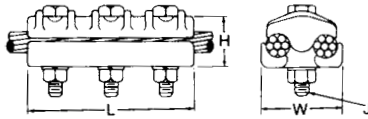

FIGURE 2

For aluminum to aluminum and aluminum to copper conductor splice/tap connectors. Sealant (XB) is recommended on all connections.

Material: Body - Aluminum alloy
Hardware - Galvanized steel

Notes: 1) For connectors without sealant, delete suffix "XB."
2) Add suffix "GP" for a tin-plated connector.

Product Data & Conductor Size

CATALOG NUMBER	FIGURE NO.	CONDUCTOR RANGE		DIMENSIONS INCHES (MM)				APPROX. WT. EACH LBS. (KG)
		MAIN	TAP	L	W	H	J	
GA670L	1	1/0-400 AAC 1/0-336.4 (18/1) ACSR	1/0-400 AAC 1/0-336.4 (18/1) ACSR	3-1/4 (82.71)	2-1/4 (57.26)	2-3/4 (69.85)	3/8 (9.53)	.60 (.27)
LC66AXB	1	1/0 (19)-400 MCM AAC 1/0-397.5 (18/1) ACSR	1/0 (19)-400 MCM AAC	3-1/2 (88.90)	2-3/8 (60.44)	2-3/4 (69.85)	1/2 (12.70)	1.10 (.50)
LC67AXB	2		1/0 Sol.-400 MCM Cu	5-1/4 (133.35)	2-5/8 (66.80)	2-1/2 (63.5)	1/2 (12.70)	1.30 (.59)
LC68AXB	2	350-556.5 MCM AAC 336.4 (18/1)-477 (30/7) ACSR	350-556.5 MCM AAC 336.4 (18/1)-477 (30/7) ACSR 350-550 MCM Cu	5-1/4 (133.35)	2-13/16 (71.44)	2-1/2 (63.5)	1/2 (12.70)	1.90 (.86)

DD
20

ALUMINUM
LC70

GENERAL USE PARALLEL GROOVE - ALUMINUM SINGLE U-BOLT

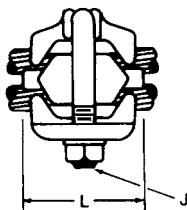
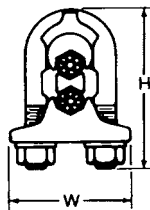

For aluminum to aluminum and aluminum to copper conductor splice/tap connections and also aluminum or ACSR loop dead-ends. Sealant (XB) is recommended on all connections, except loop dead-ends.

Material: Body—Top, spacer & bottom members—Aluminum Alloy
Hardware—Galvanized steel

Product Data & Conductor Size

CATALOG NUMBER	CONDUCTOR RANGE		DIMENSIONS INCHES (MM)				APPROX. WT. EACH LBS. (KG)
	MAIN	TAP	L	W	H	J	
LC71B**	#6 Sol.-2/0 Str. AAC #8-2/0 ACSR	#6 Sol.-2/0 Str. AAC #8-2/0 ACSR	2 (50.80)	2 (50.80)	3-1/4 (82.55)	3/8 (9.53)	.43 (.20)
LC72B	#6 Sol.-2/0 Str. AAC #8-2/0 ACSR	#6 Sol.-2/0 Str. AAC #8-2/0 ACSR	2-1/4 (57.15)	2-1/4 (57.15)	3-3/8 (85.73)	1/2 (12.70)	.77 (.35)
LC73B	1/0 Sol.-400 MCM AAC 1/0-336.4 MCM ACSR	#6 Sol.-1/0 Str. AAC #8-1/0 ACSR	2-3/4 (69.85)	2-5/8 (66.68)	4 (101.60)	1/2 (12.70)	1.12 (.51)
LC74B**	1/0 Sol.-400 MCM AAC 1/0-336.4 MCM ACSR	1/0 Sol.-400 MCM AAC #2-336.4 MCM ACSR	2-3/4 (69.85)	2-5/8 (66.68)	4 (101.60)	1/2 (12.70)	1.21 (.55)
LC75B	336.4-954 MCM AAC 300-795 MCM ACSR	#6 Sol.-1/0 Str. AAC #8-1/0 ACSR	3-1/4 (82.55)	3 (76.20)	4-5/8 (117.48)	1/2 (12.70)	1.43 (.65)
LC77B	336.4-1033.5 MCM AAC 300-954 (45/7) ACSR	336.4-1033.5 MCM AAC 300-954 (45/7) ACSR	3-1/2 (88.90)	3-3/8 (85.73)	5-3/8 (136.53)	5/8 (15.88)	1.97 (.89)

**RUS Listed



GENERAL USE PARALLEL GROOVE - ALUMINUM TWO U-BOLT

ALUMINUM
LCU10

For aluminum to aluminum and aluminum to copper conductor splice/tap connections. Sealant (XB) is recommended on all connections.

Material: **Body**—Top, spacer & bottom members—aluminum alloy
Hardware—Aluminum alloy

Note: For connectors without sealant, delete suffix “XB.”

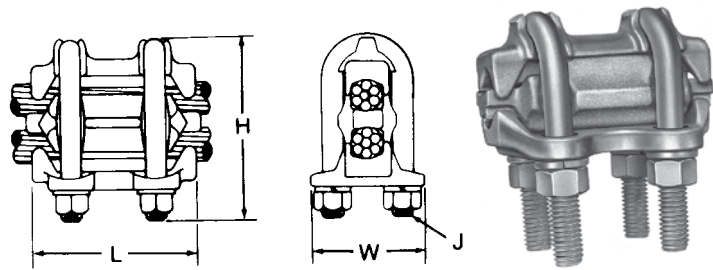

Product Data & Conductor Size

CATALOG NUMBER	CONDUCTOR RANGE		DIMENSIONS INCHES (MM)				APPROX. WT. EACH LBS. (KG)
	MAIN	TAP	L	W	H	J	
LCU13XB	1/0 Str.—400 MCM AAC 1/0—397.5 (18/1) ACSR	1/0 Str.—400 MCM AAC 1/0—397.5 (18/1) ACSR 1/0 Str.—400 MCM Cu	4-1/8 (104.78)	2-11/16 (68.26)	4-1/2 (114.30)	1/2 (12.70)	1.07 (.49)
LCU15XB	336.4—954 MCM AAC 300—795 MCM ACSR	1/0 Str.—400 MCM AAC 1/0—397.5 (18/1) ACSR 1/0 Str.—400 MCM Cu	4-5/8 (117.48)	3-1/16 (77.79)	4-7/8 (123.83)	1/2 (12.70)	1.84 (.83)
LCU16XB		336.4—954 MCM AAC 300—795 MCM ACSR 350—900 MCM Cu	4-5/8 (117.48)	3-7/16 (87.31)	5-1/2 (139.70)	5/8 (15.88)	1.86 (.84)

DD
21



GENERAL USE PARALLEL GROOVE - ALUMINUM 3 U-BOLT

ALUMINUM
LCU700

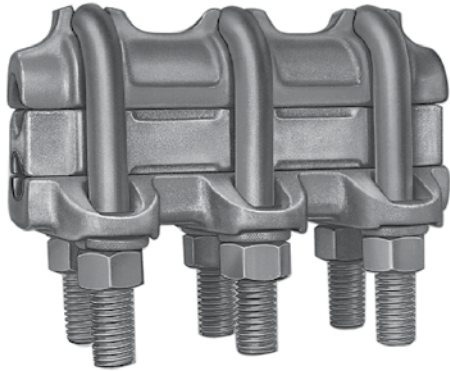

For aluminum to aluminum and aluminum to copper conductor splice/tap connections. Sealant (XB) is recommended on all connections.

Material: **Body** - Top, spacer & bottom members—
Aluminum alloy
Hardware - Aluminum alloy

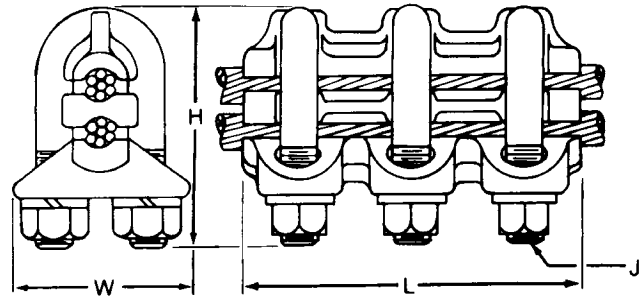

DD
22

Product Data & Conductor Size

CATALOG NUMBER	CONDUCTOR RANGE		DIMENSIONS INCHES (MM)				APPROX. WT. EACH LBS. (KG)
	MAIN	TAP	L	W	H	J	
LCU70055	450—800 MCM AAC 397.5—715.5 MCM ACSR	450—800 MCM AAC 397.5—715.5 MCM ACSR	5-7/8 (149.23)	3-1/8 (79.38)	4-11/16 (119.06)	5/8 (15.88)	2.87 (1.30)
LCU70063	750—1033.5 MCM AAC 605—900 MCM ACSR	4/0 Sol. — 350 MCM AAC 3/0 — 336.4 (18/1) ACSR	6-3/4 (171.45)	3-5/16 (84.14)	5-1/8 (130.18)	5/8 (15.88)	3.25 (1.47)
LCU70064		350—477 MCM AAC 336.4—397.5 MCM ACSR	6-3/4 (171.45)	3-5/16 (84.14)	5-1/8 (130.18)	5/8 (15.88)	3.25 (1.47)
LCU70065		450—715.5 MCM AAC 397.5 — 605 MCM ACSR	6-3/4 (171.45)	3-5/16 (84.14)	5-1/8 (130.18)	5/8 (15.88)	3.50 (1.59)
LCU70066		750—1033.5 MCM AAC 605—900 MCM ACSR	6-3/4 (171.45)	3-5/16 (84.14)	5-1/2 (139.70)	5/8 (15.88)	3.50 (1.59)
LCU70074		1113—1351.5 MCM AAC 954—1192.5 MCM ACSR	350—477 MCM AAC 336.4—397.5 MCM ACSR	8 (203.20)	3-7/8 (98.43)	6 (152.40)	3/4 (19.05)
LCU70076	750—1033.5 MCM AAC 605—900 MCM ACSR		8 (203.20)	3-7/8 (98.43)	6 (152.40)	3/4 (19.05)	6.50 (2.95)
LCU70077	1113—1351.5 MCM AAC 954—1192.5 MCM ACSR		8 (203.20)	3-7/8 (98.43)	6-3/8 (161.93)	3/4 (19.05)	6.50 (2.95)
LCU70085	1431—1750 MCM AAC 1272—1590 MCM ACSR		450—715.5 MCM AAC 397.5 — 605 MCM ACSR	9-3/4 (231.78)	4-1/8 (104.78)	5-3/4 (146.05)	3/4 (19.05)
LCU70086		750—1033.5 MCM AAC 605—900 MCM ACSR	9-3/4 (231.78)	4-1/8 (104.78)	6-3/8 (161.93)	3/4 (19.05)	8.50 (3.86)
LCU70087		1113—1351.5 MCM AAC 954—1192.5 MCM ACSR	9-3/4 (231.78)	4-1/8 (104.78)	6-3/8 (161.93)	3/4 (19.05)	8.75 (3.97)
LCU70088		1431—1750 MCM AAC 1272—1590 MCM ACSR	9-3/4 (231.78)	4-1/8 (104.78)	6-3/8 (161.93)	3/4 (19.05)	8.75 (3.97)
LCU7001006		2000—2500 MCM AAC 1780—2156 ACSR	750—1033.5 MCM AAC 605—900 MCM ACSR	10 (254.0)	4-3/8 (111.12)	7 (177.8)	3/4 (19.05)
LCU7001007	1113—1351.5 MCM AAC 954—1192.5 MCM ACSR		10 (254.0)	4-3/8 (111.12)	7 (177.8)	3/4 (19.05)	7.85 (3.53)
LCU7001010	2000—2500 MCM AAC		10 (254.0)	4-3/8 (111.12)	7 (177.8)	3/4 (19.05)	6.85 (3.08)
	1780—2156 MCM ACSR		10 (254.0)	4-3/8 (111.12)	7 (177.8)	3/4 (19.05)	6.85 (3.08)



GENERAL USE SPLIT BOLT WITH SEPARATOR BAR: ALUMINUM AND BRONZE

BRONZE/ALUMINUM
SBS

For aluminum to aluminum or copper conductors.

Material: Type SBS — Copper Alloy, Electro Tin-Plated

Note: VERSA-SEAL® oxide inhibiting compound is recommended for use with Al/Cu parallel connectors.

* Hex Head design for maximum tool ease of use.

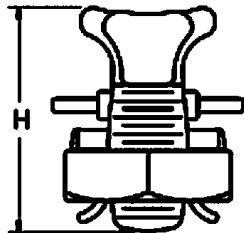
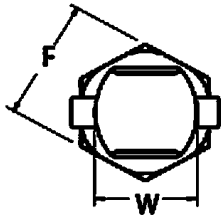

LISTED
261L

DD
23

Product Data & Conductor Size

CATALOG NUMBER	CONDUCTOR RANGE OF EQUAL MAIN & TAP (AWG OR MCM)		MIN. TAP WITH ONE MAX. MAIN	BOLT SIZE	DIMENSIONS INCHES (MM)			APPROX. WT. EACH LBS. (KG)
	MAIN	TAP			F	W	H	
SBS6	8	6*	14	7/16	5/8 (15.88)	.49 (12.45)	1.06 (26.92)	0.06 (.03)
SBS4	8	4	10	1/2	13/16 (20.63)	.71 (18.03)	1.24 (31.5)	0.09 (.04)
SBS2	6	2	14	9/16	7/8 (22.22)	.75 (19.05)	1.44 (36.58)	0.12 (.05)
SBS10	4	1/0	10	11/16	15/16 (23.81)	.79 (20.07)	1.73 (43.94)	0.18 (.08)
SBS20	2	2/0	8	3/4	1-1/16 (26.97)	.87 (22.10)	1.71 (43.43)	0.21 (.10)
SBS30	1	3/0	8	7/8	1-1/4 (31.75)	1.10 (27.94)	2.13 (54.10)	0.35 (.16)
SBS250	1	250	8	1	1-3/8 (34.93)	1.10 (27.94)	2.22 (56.39)	0.39 (.18)
SBS350	2/0	350	1/0	1-1/2	1-1/2 (38.01)	1.22 (30.99)	2.56 (65.02)	0.60 (.27)
SBS500	300	500	2/0	1-5/8	1-3/4 (44.45)	1.34 (34.04)	2.95 (74.93)	0.85 (.39)

*AL9CU (90° C Rated)

** Not UL Listed or CSA certified for aluminum to copper connections. UL listed for copper connections only.



GENERAL USE SPLIT BOLT CONNECTOR — BRONZE

BRONZE
SBN

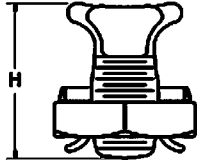
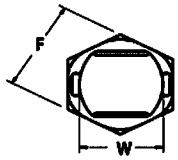

For copper to copper 2-wire conductor connection.

Material: Body — Copper Alloy



LISTED
261L



Product Data & Conductor Size

CATALOG NUMBER	CONDUCTOR RANGE OF EQUAL MAIN & TAP (AWG OR MCM)		MIN. TAP WITH ONE MAX. MAIN	BOLT SIZE	DIMENSIONS INCHES (MM)			APPROX. WT. EACH LBS. (KG)
	MIN.	MAX.			F	W	H	
SBN8	10	8	16	3/8	9/16 (14.29)	.47 (12)	.85 (21.59)	0.04 (.02)
SBN6	8	6*	16	7/16	5/8 (15.88)	.49 (12.45)	.91 (23.11)	0.05 (.02)
SBN4	8	4	14	1/2	13/16 (20.63)	.71 (18.03)	1.16 (29.46)	0.08 (.04)
SBN2	6	2	14	9/16	7/8 (22.22)	.75 (19.05)	1.25 (31.75)	0.09 (.04)
SBN10	4	1/0	14	11/16	15/16 (23.81)	.79 (20.07)	1.54 (39.12)	0.14 (.06)
SBN20	2	2/0	14	3/4	1-1/16 (26.97)	.87 (22.10)	1.69 (42.93)	0.19 (.09)
SBN30	1	3/0	8	7/8	1-1/4 (31.75)	1.10 (27.94)	2.09 (53.09)	0.30 (.14)
SBN250	1	250	8	1	1-3/8 (34.93)	1.10 (27.94)	2.09 (53.09)	0.34 (.15)
SBN350	2/0	350	1/0	1-1/2	1-1/2 (38.01)	1.22 (30.99)	2.36 (59.94)	0.51 (.23)
SBN500	300	500	2/0	1-5/8	1-3/4 (44.45)	1.34 (34.04)	2.83 (71.88)	0.73 (.33)
C750	350	750	8	1-15/16	2-1/8 (53.97)	1.94 (49.28)	3.56 (90.42)	1.76 (.80)
C1000	500	1000	8	2-1/4	2-1/8 (53.97)	2.25 (57.15)	4.03 (102.36)	2.8 (1.27)

*Solid Conductor

BRONZE
ST

GENERAL USE PARALLEL GROOVE — BRONZE SINGLE CENTER BOLT

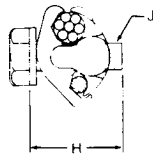
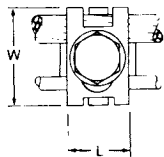

For copper (Cu), Copperweld (CW) and guy strand (GS) connections.

Material: Body—High strength Bronze Alloy
Hardware—Silicon Bronze or Stainless Steel

Add Suffix "TP" for Tin-Plated Version.

Product Data & Conductor Size

CATALOG NUMBER	CONDUCTOR RANGE (AWG)		L	DIMENSIONS INCHES (MM)			APPROX. WT. EACH LBS. (KG)
	MAIN	TAP		W	H	J	
ST3	#8 Sol.—2/0 Str. Cu #8 A—2/0 F CW 1/8"—7/16" CW/GS .125"—.438"	#8 Sol.—2/0 Str. Cu #9 1/2D—2/0 F CW 1/8"—7/16" CW/GS .125"—.438"	7/8 (22.2)	1-1/2 (38.1)	1-1/2 (38.1)	5/16 (7.9)	.22 (9.98)
ST4	#6 Sol.—4/0 Str. Cu #6A—4/0 F CW 1/4"—9/16" CW/GS .162"—.562"	#6 Sol.—4/0 Str. Cu #6A—4/0 F CW 1/4"—9/16" CW/GS .162"—.562"	15/16 (23.8)	1-7/8 (47.6)	1-1/2 (38.1)	3/8 (9.5)	.30 (13.61)

DD
24



GENERAL USE - PARALLEL BRONZE

For copper to copper conductor connections.

Material: **Body** - High strength bronze alloy
Retaining Ring - Neoprene rubber
Hardware - Silicon bronze

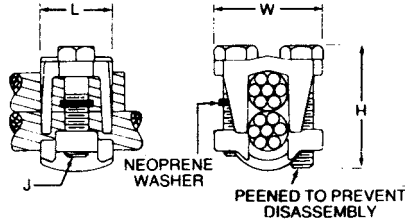

"TP" = Tin-Plated Version.

Product Data & Conductor Size

CATALOG NUMBER	CONDUCTOR RANGE (AWG)		DIMENSIONS INCHES (MM)				APPROX. WT. EACH LBS. (KG)
	MAIN	TAP	L	W	H	J	
K1	#4 Str.—1/0 Str. Cu	#8 Sol.—1/0 Str. Cu	15/16 (23.81)	1-5/16 (33.34)	1-5/16 (33.34)	5/16 (7.94)	.125 (.06)
K2	#3 Str.—2/0 Str. Cu	#8 Sol.—2/0 Str. Cu	1-1/16 (26.99)	1-5/8 (41.28)	1-21/32 (42.07)	3/8 (9.53)	.29 (.13)
K3	#1 Str.—4/0 Str. Cu	#8 Sol.—4/0 Str. Cu	1-1/8 (28.58)	1-3/4 (44.45)	1-15/16 (49.21)	3/8 (9.53)	.40 (.18)
K41	2/0 Str.—350 MCM Cu	#8 Sol.—350 MCM Cu	1-3/8 (34.93)	2-1/8 (53.98)	2-3/8 (60.33)	1/2 (12.70)	.655 (.30)
K5	3/0 Str.—500 MCM Cu	#8 Sol.—500 MCM Cu	1-1/2 (38.10)	2-1/4 (57.15)	2-11/16 (68.26)	1/2 (12.70)	.80 (.36)
K6	350—800 MCM Cu	#8 Sol.—800 MCM Cu	1-5/8 (41.28)	2-1/2 (63.50)	3-3/16 (80.96)	1/2 (12.70)	1.00 (.45)
K7	500—1000 MCM Cu	#8 Sol.—1000 MCM Cu	2 (50.80)	3 (76.70)	3-11/16 (93.66)	5/8 (15.88)	2.13 (.97)

* For equal length bolts (Separable), Add "L" Suffix.
 For Tin-Plating, add "TP" Suffix - Consult Factory.

GENERAL USE - PARALLEL BRONZE WITH SEPARATOR

For copper to copper conductor connections.

Material: **Body** - High strength bronze alloy
Separator - Copper alloy
Retaining Ring - Neoprene rubber
Hardware - Silicon bronze

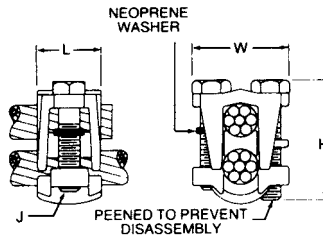

Product Data & Conductor Size

CATALOG NUMBER	CONDUCTOR RANGE (AWG or MCM)		DIMENSIONS INCHES (MM)				APPROX. WT. EACH LBS. (KG)
	MAIN	TAP	L	W	H	J	
KR1	#4 Str.—1/0 Str. Cu	#8 Sol.—1/0 Str. Cu	15/16 (23.81)	1-5/16 (33.34)	1-1/2 (38.10)	5/16 (7.94)	.18 (.08)
KR2	#3 Str.—2/0 Str. Cu	#6 Sol.—2/0 Str. Cu	1-1/16 (26.99)	1-5/8 (41.28)	1-25/32 (45.24)	3/8 (9.53)	.35 (.16)
KR3	#1 Str.—4/0 Str. Cu	#6 Sol.—4/0 Str. Cu	1-1/8 (28.58)	1-3/4 (44.45)	2-1/8 (53.98)	3/8 (9.53)	.43 (.19)
KR4	2/0 Str.—350 MCM Cu	#4 Sol.—350 MCM Cu	1-3/8 (34.93)	2-1/8 (53.98)	2-9/16 (65.09)	1/2 (12.70)	.78 (.35)
KR5	3/0 Str.—500 MCM Cu	#4 Sol.—500 MCM Cu	1-1/2 (38.10)	2-1/4 (57.15)	2-15/16 (74.61)	1/2 (12.70)	.86 (.39)
KR6	350—800 MCM Cu	#2 Str.—800 MCM Cu	1-5/8 (41.28)	2-1/2 (63.50)	3-7/16 (87.31)	1/2 (12.70)	1.25 (.57)
KR7	450—1000 MCM Cu	1/0 Str.—1000 MCM Cu	2 (50.80)	3 (76.70)	4 (101.60)	5/8 (15.88)	2.45 (1.11)

* For equal length bolts (Separable), Add "L" Suffix.
 For Tin-Plating, add "TP" Suffix - Consult Factory.



GENERAL USE PARALLEL GROOVE BRONZE SINGLE U-BOLT

BRONZE
LC1000

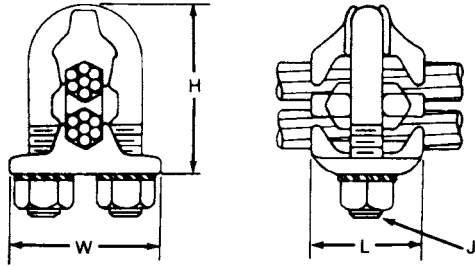

For copper to copper conductor connections.

Material: **Body Halves** - High strength Bronze alloy
Separator - Copper alloy
Hardware - Silicon bronze

Product Data & Conductor Size

CATALOG NUMBER	CONDUCTOR RANGE (AWG OR MCM)		DIMENSIONS INCHES (MM)				APPROX. WT. EACH LBS. (KG)
	MAIN	TAP	L	W	H	J	
LC1002*	#2 Sol.—2/0 Str. Cu	#2 Sol.—2/0 Str. Cu	1-1/2 (38.10)	1-15/16 (49.21)	2-3/4 (69.85)	3/8 (9.53)	.65 (.29)
LC1003*	#1 Sol.—4/0 Str. Cu	#1 Sol.—4/0 Str. Cu	1-3/4 (44.45)	2-5/16 (58.74)	3 (76.20)	1/2 (12.70)	1.00 (.45)
LC1004	1/0 Sol.—300 MCM Cu	1/0 Sol.—300 MCM Cu	2 (50.80)	2-7/16 (61.91)	3-1/2 (88.90)	1/2 (12.70)	1.15 (.52)

* Add "TP" Suffix for Tin-Plated Connector

GENERAL USE PARALLEL GROOVE BRONZE 2 U-BOLT

BRONZE
LC1100

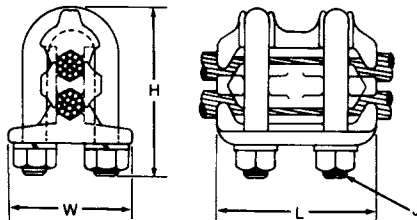
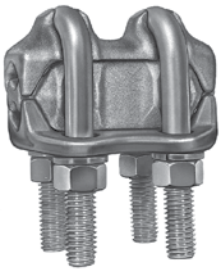

For copper to copper conductor connections.

Material: **Body Halves** - High strength Bronze alloy
Separator - Copper alloy
Hardware - Silicon bronze

Product Data & Conductor Size

CATALOG NUMBER	CONDUCTOR RANGE (AWG OR MCM)		DIMENSIONS INCHES (MM)				APPROX. WT. EACH LBS. (KG)
	MAIN	TAP	L	W	H	J	
LC1133	#1 Sol.—4/0 Str. Cu	#1 Sol.—4/0 Str. Cu	2-3/4 (69.85)	1-15/16 (49.21)	3 (76.20)	3/8 (9.53)	1.60 (.73)
LC11445	1/0 Sol.—350 MCM Cu	1/0 Sol.—350 MCM Cu	3-1/4 (82.55)	2-1/2 (63.50)	3-3/4 (92.25)	1/2 (12.70)	2.25 (1.02)
LC1155	4/0 Sol.—500 MCM Cu	4/0 Sol.—500 MCM Cu	3-3/8 (85.73)	2-5/8 (66.68)	4 (101.60)	1/2 (12.70)	2.40 (1.09)
LC1166	300—750 MCM Cu	300—750 MCM Cu	3-5/8 (92.08)	2-15/16 (74.61)	4-1/2 (114.30)	1/2 (12.70)	2.90 (1.32)
LC1177	500—1000 MCM Cu	500—1000 MCM Cu	4 (101.60)	3-1/16 (77.79)	5 (127.00)	1/2 (12.70)	3.62 (1.64)



GENERAL USE PARALLEL GROOVE - 4 WAY, 2/4 BOLT BRONZE

BRONZE
XP®

For copper to copper conductors cross, tee, parallel or end to end connections.

Material: **Body Members**—High strength bronze
Separator—Copper alloy
Hardware—Silicon bronze or Stainless Steel

Note: Add suffix "TP" for tin-plated connector.

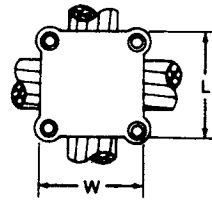
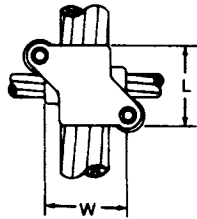
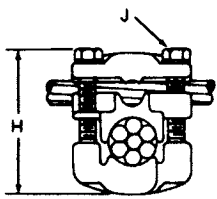

FIGURE 1

FIGURE 2



DD
27

Product Data & Conductor Size

CATALOG NUMBER	FIGURE NO.	CONDUCTOR RANGE (AWG OR MCM)		DIMENSIONS INCHES (MM)				APPROX. WT. EACH LBS. (KG)
		MAIN	TAP	L	W	H	J	
XP024024	1	#1 Str.—4/0 Str. Cu	#1 Str.—4/0 Str. Cu	1- 7/8 (47.63)	1- 7/8 (47.63)	2-9/16 (65.09)	3/8 (9.53)	.70 (.32)
XP050050	2	4/0 Str.—500 MCM Cu	4/0 Str.—500 MCM Cu	2 (50.80)	2 (50.80)	3-3/16 (80.96)	3/8 (9.53)	1.40 (.64)
XP100050	2	500—1000 MCM Cu	4/0 Str.—500 MCM Cu	2 (50.80)	2 (50.80)	3-3/8 (85.73)	3/8 (9.53)	1.70 (.77)
XP100100	2	500—1000 MCM Cu	500—1000 MCM Cu	2-1/2 (63.50)	2-1/2 (63.50)	3-11/16 (93.66)	3/8 (9.53)	2.40 (1.09)



GENERAL USE PARALLEL GROOVE BRONZE MULTIPLE CENTER BOLT

BRONZE
LC400

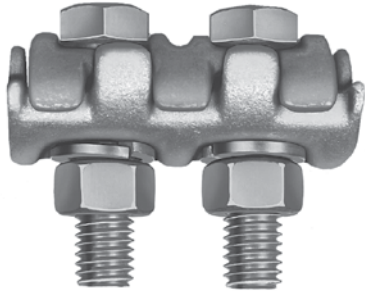

FIGURE 1

For copper to copper conductor connections.

Material: Body - High strength bronze alloy
Hardware - Silicon bronze or Stainless Steel

Add suffix "TP" for tin-plated Connector.

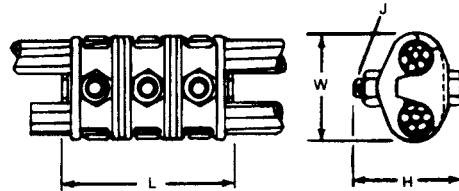

FIGURE 2

Product Data & Conductor Size

CATALOG NUMBER	FIGURE NO.	CONDUCTOR RANGE (AWG OR MCM)		DIMENSIONS INCHES (MM)				APPROX. WT. EACH LBS. (KG)
		MAIN	TAP	L	W	H	J	
LC402	1	#4 Sol.—4/0 Str. Cu	#4 Sol.—4/0 Str. Cu	2-9/32 (57.94)	1-27/32 (46.83)	2-1/4 (57.15)	3/8 (9.53)	.82 (.37)
LC4025	1	#4 Sol.—4/0 Str. Cu	#4 Sol.—4/0 Str. Cu	2-13/16 (71.44)	2 (50.80)	2-1/4 (57.15)	1/2 (12.70)	1.38 (.62)
LC4035	1	#2 Sol.—300 MCM Cu	#2 Sol.—300 MCM Cu	3-1/8 (79.38)	2-1/4 (57.15)	2-1/4 (57.15)	1/2 (12.70)	1.79 (.81)
LC404	2	4/0 Str.—500 MCM Cu	4/0 Str.—500 MCM Cu	4-3/8 (111.13)	2-5/8 (66.68)	2-5/8 (66.68)	1/2 (12.70)	2.99 (1.36)
LC406	2	500—1000 MCM Cu	500—1000 MCM Cu	5-1/8 (130.18)	3-1/2 (88.90)	3-3/8 (85.73)	1/2 (12.70)	4.70 (2.13)

GENERAL USE PARALLEL GROOVE BRONZE SINGLE CENTER BOLT

BRONZE
LC1600

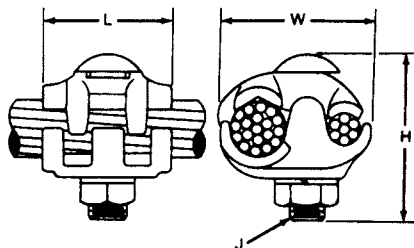
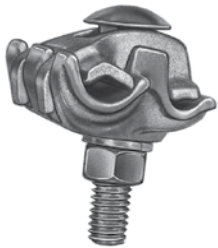

For copper to copper conductor connections.

Material: Body - High strength bronze alloy
Hardware - Silicon bronze or Stainless Steel

Add suffix "TP" for tin-plated Connector.

Product Data & Conductor Size

CATALOG NUMBER	CONDUCTOR RANGE (AWG OR MCM)		DIMENSIONS INCHES (MM)				APPROX. WT. EACH LBS. (KG)
	MAIN	TAP	L	W	H	J	
LC1601	1/0 Sol.—4/0 Str. Cu	#8 Sol.—#1 Str. Cu	2 (50.80)	1-3/4 (44.45)	2 (50.80)	3/8 (9.53)	.58 (.26)
LC1602	1/0 Sol.—400 MCM Cu	#8 Sol.—3/0 Str. Cu	2-3/8 (60.33)	2-1/4 (57.15)	2-3/4 (69.85)	1/2 (12.70)	1.05 (.48)



GENERAL USE SETSCREW TERMINAL PADS BRONZE 2 OR 3 CABLES TO PAD

BRONZE
LU2 & LU3

UL Listed for two or three copper conductors.

Material: **Body** – Bronze alloy
Hardware – Plated Steel

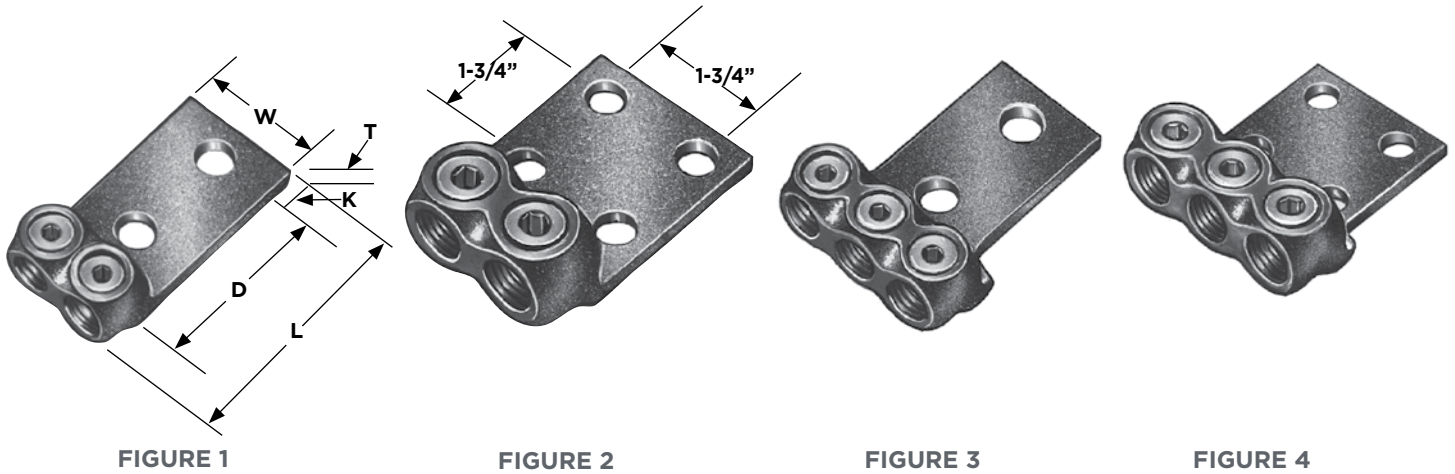

DD
29



Product Data & Conductor Size

CATALOG NUMBER	FIGURE NO.	COPPER CONDUCTOR RANGE (AWG OR MCM)	PAD BOLT SIZE	DIMENSIONS INCHES (MM)					APPROX. WT. EACH LBS. (KG)
				L	D	K	W	T	
LU2102N	1	#4 Sol.—1/0 Str.	1/2	4 (101.6)	3-9/16 (90.49)	5/8 (15.88)	1-1/2 (38.10)	1/4 (6.35)	38 (17.23)
LU23002N	1	2/0 Str.—300 MCM	1/2	4-1/8 (104.78)	3-1/2 (88.90)	5/8 (15.88)	2 (50.80)	1/4 (6.35)	117 (53.05)
LU25002N	1	4/0 Str.—500 MCM	1/2	4-1/2 (114.30)	3-7/8 (98.43)	5/8 (15.88)	2-1/2 (63.50)	1/2 (12.70)	184 (83.44)
LU35002N	3	4/0 Str.—500 MCM	1/2	4-1/2 (114.30)	3-5/8 (92.08)	5/8 (15.88)	2-1/2 (63.50)	5/8 (15.88)	227 (102.94)
LU25004N	2	4/0 Str.—500 MCM	1/2	4-1/2 (114.30)	3-3/4 (95.25)	5/8 (15.88)	3 (76.20)	3/8 (9.53)	205 (92.96)
LU35004N	4	4/0 Str.—500 MCM	1/2	4-1/2 (114.30)	3-5/8 (92.08)	5/8 (15.88)	3 (76.20)	1/2 (12.70)	247 (112.01)
*LU310004N	4	500—1000 MCM	1/2	5-3/16 (131.76)	3-7/8 (98.43)	5/8 (15.88)	3-1/4 (82.55)	5/8 (15.88)	512 (232.19)

*Not UL Listed or CSA Approved.



GENERAL USE SETSCREW LUGS BRONZE

BRONZE
KA-H



UL Listed for copper conductor.

Material: Body—Copper or bronze alloy
Hardware—Plated steel

Compacted, economical, high copper alloy terminal for joining a wide range of cable to equipment pads or terminal blocks.

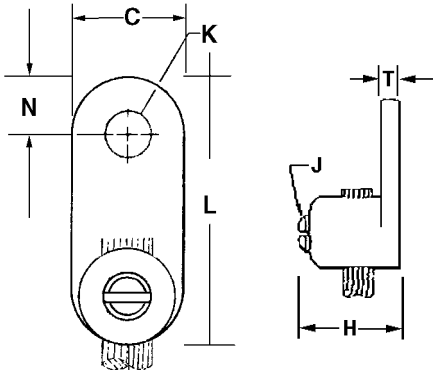

FIGURE 1

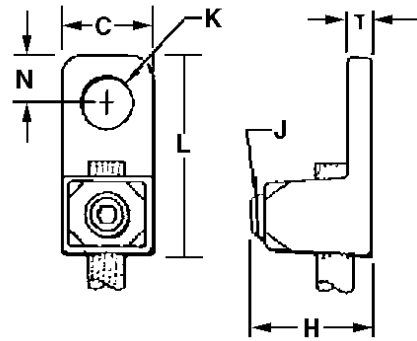

FIGURE 2

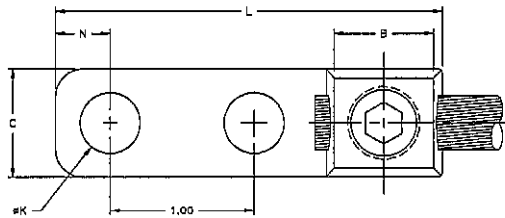

FIGURE 3

Product Data & Conductor Size

CATALOG NUMBER	FIGURE NO.	COPPER CONDUCTOR RANGE (AWG OR MCM)	PAD BOLT SIZE	DIMENSIONS INCHES (MM)							RECOMMENDED TIGHTENING TORQUE IN-LB	APPROX. WT. EACH LBS. (KG)
				C	H	J	K	L	N	T		
KA8CH	1	#14 Sol.—#8 Str.	#10	3/8 (9.55)	5/8 (15.87)	#12	7/32 (5.56)	13/16 (20.64)	3/16 (4.76)	3/32 (2.38)	25	1 (.45)
KA4CH	1	#14 Sol.—#4 Str.	1/4	9/16 (14.29)	3/4 (19.05)	5/16 (7.94)	9/32 (7.14)	1-1/8 (28.57)	1/4 (6.35)	7/64 (2.78)	45	3 (1.36)
KA25H	2	#4 Str.—1/0 Str.	3/8	3/4 (19.05)	15/16 (23.81)	1/2 (12.7)	27/64 (10.72)	1-1/16 (26.99)	3/8 (9.55)	1/8 (3.17)	200	13 (5.90)
KA252TC38H	3	#4 Str.—1/0 Str.	3/8	3/4 (19.05)	15/16 (23.81)	1/2 (12.7)	27/64 (10.72)	2-13/16 (71.44)	3/8 (9.55)	1/8 (3.17)	200	15 (6.80)
KA28H	2	#1 Str.—4/0 Str.	3/8	15/16 (23.81)	1-1/4 (31.75)	5/8 (15.87)	27/64 (10.72)	1-15/16 (49.21)	7/16 (11.11)	3/16 (4.75)	275	22 (9.98)
KA34H	2	4/0 Str.—500 MCM	1/2	1-3/8 (34.95)	2-3/32 (53.18)	13/16 (20.64)	9/16 (14.29)	2-9/16 (65.09)	9/16 (14.29)	9/32 (7.14)	375	71 (32.21)

Listed torque values are for maximum conductor sizes accommodated. Consult UL486 Tables 7-4, 7-5, 7-6 for smaller conductor sizes.

DD
30



SNAP TAP™ PLASTIC COVER

PLASTIC
PTC

PTC1 & 2 Snap-on covers for aluminum compression taps.

PTC51 & 52 Snap-on covers for mechanical center bolt taps.

Material: Black plastic



PTC51



PTC1

DD
31

Product Data & Conductor Size

CATALOG NUMBER	DESCRIPTION	APPROX. WT. EACH LBS. (KG)
PTC1**	For use on "O" die AC's or any H-frame connectors up to 1 3/4" long	.045 (.0204)
PTC2**	For use on "D" die AC's or any H-frame connectors up to 2 1/2" long, VCP-43A, VCP-44 VAC-1040 and VAC-4040	.070 (.0318)
PTC51**	For use on center bolt connectors LC-51A, LC-51C, LC52A, LC511A and LC-522A	.052 (.0236)
PTC52**	For use on center bolt connectors LC-52C, LC-81A, LC-811A, LC-542	.082 (.0372)

**RUS Listed