

Workshop Solutions

One call for complete peace of mind



Garage Equipment, Tools,
Training & Technology



One call for complete peace of mind – Workshop Solutions

Your business is your livelihood. We understand that and we care. At Workshop Solutions we provide you with all the equipment, service, repair and maintenance programmes, assistance with health & safety procedures and project planning skills you need all in one place. We are the equipment and service provider of choice to many motor manufacturer groups, independent garages and bodyshops nationwide. From a new compressor to an MOT bay, comprehensive building works to aftersales servicing and maintenance, Workshop Solutions manages the whole process, ensuring a smooth, hassle-free, one-stop service that is delivered on time and on budget.



Our panel of finance houses can spread the cost tax-efficiently



From preventative maintenance plans to emergency call-outs



Waste Management – Keeping you fully compliant and stress free

THE LATEST TECHNOLOGY FROM THE BEST BRANDS

We aim to provide you with the tools, equipment and service that match both your personal expectations and your business requirements.



Health & Safety – Safeguarding your people and your business



Please contact our Equipment Service & Maintenance team on 01527 882 778 to arrange an initial free, no obligation consultation.

DO YOU PAY YOUR STAFF 5 YEARS IN ADVANCE? NO, SO WHY PAY FOR YOUR EQUIPMENT THAT WAY! **PAY FOR IT AS IT WORKS FOR YOU!**

NO HASSLE WARRANTY

BEST PRICE PROMISE

- Fixed payments (excluding VAT)
- Tax efficient – see table
- Preserves working capital
- 1–5 year terms available
- No deposit
- Why wait? Buy the equipment your business needs now!

EQUIPMENT VALUE (EXCLUDING VAT) – £5,000

2 YEARS LEASE

Weekly Payment	£55.47
First Payment	£240.35
23 Payments	£240.35
Total Cost	£5,768.40
Tax Relief @ 20%	£5,768.40
Net Cost of Finance	£4,614.72

3 YEARS LEASE

Weekly Payment	£38.61
First Payment	£167.30
35 Payments	£167.30
Total Cost	£6,022.80
Tax Relief @ 20%	£1,204.56
Net Cost of Finance	£4,818.24

4 YEARS LEASE

Weekly Payment	£30.21
First Payment	£130.90
23 Payments	£130.90
Total Cost	£6,283.20
Tax Relief @ 20%	£1,256.64
Net Cost of Finance	£5,026.56

5 YEARS LEASE

Weekly Payment	£25.20
First Payment	£109.20
23 Payments	£109.20
Total Cost	£6,552.00
Tax Relief @ 20%	£1,310.40
Net Cost of Finance	£5,241.60

Payments shown above are subject to businesses trading more than 3 years, credit approval and VAT. New start businesses may require a higher rate. The tax relief shown is an illustration only. Euro Car Parts Ltd is regulated by the Financial Conduct Authority (FCA) reference number 559185.

*Finance example typically based on a 5 year lease purchase agreement. Finance subject to status, full terms and conditions available on request. Other finance options available. All prices exclude VAT at 20%. Price, availability and specification may change without prior notice. Warranty subject to manufacturers terms and conditions of use. Errors and omissions excluded. Offers valid until 31st March 2017. Prices correct at time of going to press: December 2016.

0845 603 3636
OVER 200 BRANCHES NATIONWIDE

Welcome to the latest edition of Workshop Solutions magazine, which is packed with information on all the latest garage equipment from some of the UK's biggest equipment brands. But we're not just here to sell you Garage Equipment. As our name suggests, we're here to help provide solutions to some of the challenges facing your workshop.

Let's start with news about a new training initiative, Euro Academy, which is designed specifically to support you, our independent garage customers.

With IMI-certified training and a unique and innovative technical resource, this is a membership based initiative that includes a technical helpline plus an online diagnostics database incorporating a huge reference library of previous faults.

This resource is enhanced by Euro Academy training, which covers all areas of vehicle maintenance, including electrical, electronic, mechanical and diagnostic fault finding. For Master Technicians, courses take place at one of our IMI-approved training centres, which boast more than 30 cars fitted with electronic fault simulators, which are all able to replicate real-life vehicle issues.

Helping you to understand your own training requirements, the skills of new team members or the order in which courses are taken, is vital before you invest. Full access is also given to unlimited online technician assessments to enable you to decide which courses, who and when you train.

Cars continue to get more and more complicated and they're filled with highly advanced technology which requires specialist knowledge. Unqualified, untrained mechanics do not have a chance of competing against franchise dealers when working on modern cars. However, if you run a garage with all the right kit and with trained technicians that know how to use it, you've got a great future ahead of you.



TRAINING IS NOT A COST TO YOUR BUSINESS, IT'S AN INVESTMENT IN ITS FUTURE PROSPERITY.

- You'll increase productivity and decrease the need for supervision – If technicians know what they're doing and are properly trained, productivity will increase because they won't need constant supervision.
- You'll reduce employee turnover – Training your employees shows them you're keen to develop their skills; they'll stay with you longer and contribute more to your business.
- You'll gain the ability to work with new technologies – If your technicians are current with technology, they'll do their job better and ensure that your garage keeps ahead of the competition.
- You'll be able to attract better technicians to your business – If they know you're going to support their ongoing development you'll become the go-to business for top talent.
- You'll create increased job satisfaction, morale and motivation among employees – Training invariably reduces absenteeism, mistakes and stress. Providing technical training improves the reputation of your garage and the performance of technicians.

To become a Euro Academy member, just contact your local branch. Membership can be paid for in monthly instalments.

We are passionate about supporting the UK's independent garage network. Euro Academy is an example of our investment in the future of our trade customer, to ensure their businesses are well placed

to build on their strengths of quality and service through access to up-to-date technical information and training. Working in partnership with our members, we will continue to invest in and develop Euro Academy to ensure that the independent garage sector is always able to compete with franchise dealer networks.

*Finance example typically based on a 5 year lease purchase agreement. Finance subject to status, full terms and conditions available on request. Other finance options available. All prices exclude VAT at 20%. Price, availability and specification may change without prior notice. Warranty subject to manufacturers terms and conditions of use. Errors and omissions excluded. Offers valid until 31st March 2017. Prices correct at time of going to press: December 2016.

EURO ACADEMY

Today's vehicles are vastly more complex and advanced than their predecessors, and these developments will continue to happen at a rapid pace. With engine options now including petrol, diesel, electric or hybrid, modern cars typically have intricate computers controlling almost every aspect of their operation- from suspension, braking, fuel and air flow, to emissions, traction and parking assistance.

Now with main dealers having the insight and knowledge to effectively work on all the latest vehicles and components, are independent workshops at risk of being left behind?

Not if Workshop Solutions has anything to do with it. Workshop Solution's Euro Academy membership now offers you access to superb technical information and assistance in 3 different ways:



TECHNICAL HELPLINE



ONLINE FAULT LIBRARY



TRAINING FACILITY

TECHNICAL HELPLINE

The Euro Academy Technical helpline is like having another master technician standing next to you all the time. And, unlike some of our competitors, there's no limit to the amount of time you can spend on a call, or the amount of times you can call us. Our master technicians have years of practical experience along with access to the latest technical information on any vehicle, regardless of the manufacturer. So, whether you're looking for repair manuals, circuit diagrams, parts catalogues or component locations for any vehicle in your workshop, simply pick up the phone and let us help.

One simple call to our technical helpline could save you hours of searching for an elusive component failure.



ONLINE FAULT LIBRARY

With new vehicle designs, developments and technologies come new problems, issues and repair processes. And, if your diagnostics equipment isn't as up to date as these contemporary cars, then you could be left unequipped to carry out the repair.

However, this is where Euro Academy can help.

Our comprehensive online fault library offers access to over half a million technical queries. With an average of 600 repairs added to the database every day, last year alone saw over 100,000 issues fixed and recorded.

Not only do Euro Academy users get unlimited access to this online troubleshooting facility, they also have a wide range of data available to help them diagnose problems, and find the exact details of how to achieve a repair.



TRAINING

The ever-changing repair jobs that workshops have to manage mean that on-going learning is essential in the automotive industry. Currently, we have a purpose-built training centre in Avonmouth, and more due to open in Glasgow, Sunderland, Manchester, Tamworth, London and Norwich. Our academy courses cover all areas of vehicle repair including mechanical, electrical, electronic and diagnostics fault-finding and fixes.

With just a quick assessment, we are able to determine the knowledge levels of course attendees and grade them either:

- **A** (master technician)
- **B** (medium-level technician)
- **C** (entry-level technician)

This data not only helps workshop managers understand the knowledge levels of their employees, but enables us to provide the best courses and training solutions to suit their needs. In addition to expert tutors and advisers, the Euro Academy training is also provided in a blended format. This means that in order to minimise disruption for workshop operations, each subject is covered with 8 hours of e-learning at the student's home or workplace and blended with 8 hours of on-site training at a suitable venue – meaning less time spent away from the garage.

CALL YOUR LOCAL EURO CAR PARTS BRANCH MANAGER FOR FURTHER DETAILS, TO REGISTER YOUR INTEREST OR TO APPLY FOR MEMBERSHIP.

YOUR MEMBERSHIP

Becoming a Euro Academy member is an investment in your business, and one which will increase revenue and profits while saving time and money. Memberships are available by annual subscription paid monthly, and start from as little as £79.00 for level 1 subscribers.

	Full, unlimited use of helpline	Unlimited access to Euro Vehicle Troubleshooting	Unlimited Technician Assessments	Two-day training course for one technician each year	Three two-day training courses for technicians each year	
LEVEL 1 263 77 6050	•	•	•			£79.99
LEVEL 1 263 77 6060	•	•	•	•		£99.99
LEVEL 1 263 77 6070	•	•	•	•	•	£129.99

*Finance example typically based on a 5 year lease purchase agreement. Finance subject to status, full terms and conditions available on request. Other finance options available. All prices exclude VAT at 20%. Price, availability and specification may change without prior notice. Warranty subject to manufacturers terms and conditions of use. Errors and omissions excluded. Offers valid until 31st March 2017. Prices correct at time of going to press: December 2016.

EURO ACADEMY TRAINING COURSES – MEMBERS ONLY

Euro Academy training courses cover all areas of mechanical, electrical, electronic and diagnostics fault-finding and repair over the entire vehicle for members.

We offer a structured solution that spans all ability levels from Basic to Master Technician; in fact, it's all the training your business will ever need. Technicians achieve career development from Academy training, gaining qualifications that prove they are competent to repair your customers' vehicles.

Each subject is covered by eight hours of e-learning, accessed wherever and whenever it suits the technician, and eight hours of on-site practical training.

- On-site training takes place at a venue determined by the location of the trainees, and is restricted to no more than 10 technicians at a time.
- Course content is continually re-assessed and is aligned to the Euro Vehicle Troubleshooting online Helpline – as the database grows, these known faults and repairs are incorporated into the syllabus, to keep the training up to date and give technicians the information they need.
- Practical training can be held in Euro Academy's new IMI Approved Centre, where all training sessions are IMI Quality Assured.

COURSE DURATION: 2 DAYS BLENDED TRAINING

- **On-site:** 8 hours of practical training
- **E-learning:** 8 hours accessed wherever and whenever it suits the technician

ELECTRICITY AND ELECTRONICS

IMI ACCREDITED

Understanding the basic principles of electricity is a pre-cursor to any mechanic looking to up his game and move towards a diagnostic / fault finding career path. Without the basics, it is impossible to safely and effectively diagnose today's increasingly complex range of vehicles.

MULTIMETER AND OSCILLOSCOPE (HIGH LEVEL)

IMI ACCREDITED

Having grasped the basics of electricity, most mechanics will want to keep feeding their knowledge. This section takes a more detailed look at the procedures involved to be able to test and verify the many sensors and actuators found in modern vehicles. Also, as a result of more complex digital electronics, new high-speed networks (CAN, LIN, MOST) have had to be implemented.

Euro Academy Members – call 0845 603 3636 or email training@eurocarparts.com to sign in to the course you need.

DIAGNOSIS

IMI ACCREDITED

A prudent and wise mechanic will retain their customers with a proper diagnostic process, by using the skills that they have learnt, to not only replace parts, but to ensure the part that they are replacing is the cause of the problem. In this section the student will be introduced to a methodology that they will use on a daily basis.

PETROL INJECTION

IMI ACCREDITED

Gain a thorough understanding of fuel systems and how emission control standards are met. Fuel, ignition and air intake systems work hand in hand with post-ignition treatment of exhaust gases to achieve or surpass these stringent regulations. The mechanic will gain an insight as to how these systems operate and begin to successfully test and diagnose petrol injection system faults.

DIESEL INJECTION

IMI ACCREDITED

With almost 50% of all UK car sales diesel engine vehicles, this training offers an invaluable insight and introduction to basic mechanical systems, and up-to-the minute common-rail high pressure systems including the necessary safety and cleanliness requirements.

**Need more courses than your membership entitlement?
Additional courses only £159.00 per day**

AIR CONDITIONING

IMI ACCREDITED

Understand the basic operating principles and the components involved in the air conditioning, in order to be able to safely diagnose operating defects. F-gas certificate is a prerequisite.

BRAKES – LEVEL 1 & BRAKES – LEVEL 2

IMI ACCREDITED

An introduction to hydraulic circuits and components to mechanical and electrically operated handbrake systems. Safety and awareness regarding the cleanliness and contamination of brake fluid and brake warning lamps is also paramount. An overview of ABS/ESP systems and the diagnosis of errors, using diagnostic tools is then introduced.

SUSPENSION

IMI ACCREDITED

Often the importance of a correctly operating and well maintained suspension system is disregarded. This can lead to premature tyre wear and dangerously increase stopping distances. The student will be introduced to the various elements that make up traditional and active suspension systems, and how they work in conjunction with each other, including how to spot common failure areas.

STEERING

IMI ACCREDITED

Power assisted steering is now commonplace on almost all vehicles. However, before repair, a thorough understanding as to the safety and operating principles of standard non-power assisted steering must be applied. Also included - hydraulic, electric and rear steer systems.

BOSCH TRAINING COURSES*

As the world's largest supplier of advanced electronic automotive systems, vehicle manufacturers from around the world rely on Bosch for innovation and technical expertise. You can also benefit from this expertise through the range of training courses offered by Bosch at our Euro Academy Training Centre, at Bosch's own Service Training Centre (STC) in Uxbridge, or on a regional basis across the UK and Ireland.

BOSCH COURSES VENUES

- | | |
|---|---|
| <ol style="list-style-type: none"> 1. Euro Academy
Fifth Way, Avonmouth BS11 8DT 2. Training 2000 Limited
Furthergate Business Park, Harwood St, Blackburn BB1 3BD 3. DTM Diesel & Petrol Injection Specialists Ltd
Short Street, St Phillips, Avon, Bristol BS2 0SW 4. Suzuki Training Facility
Rands Lane Industrial Estate, Armthorpe, Doncaster DN3 3DY | <ol style="list-style-type: none"> 5. LAGTA Limited,
Eurocentral Scotland, Condor Glen, Holytown, Motherwell ML1 4UY 6. South Devon College
Vantage Point, Long Rd, Paignton TQ4 7EJ 7. Bosch Service and Training Centre
Riverside Way, Uxbridge UB8 2YF 8. GTG West Midlands
Bearing Dr, Wolverhampton WV11 3SZ |
|---|---|



ONLY **£159.00** PER DAY

EURO ACADEMY AVONMOUTH BOSCH COURSES* PROGRAMME

COURSE CODE	COURSE TITLE	DESCRIPTION	START DATE	DURATION
VSE1	Essential Electrics	Gain a working knowledge of standard electrical test procedures and how they are applied correctly.	07/02/17	2 days
VSB8 (2 DATES)	Airbag and SRS	Gain knowledge of Airbag and SRS control systems and learn how to carry out accurate diagnosis on these safety critical systems	14/02/17 04/04/17	2 days
VSTD9 (2 DATES)	Oscilloscope Operation...	Competently operate an oscilloscope and use all its functions	21/02/17 26/04/17	2 days
VSG2	Spark Ignition...	Gain an in-depth understanding of the ignition process and analysis of ignition related faults	28/02/17	2 days
VSH24.1	Hybrid Routine Maintenance	Learn how to identify high-voltage components and how to safely carry out maintenance work in that environment*	14/03/17	2 days
VSC6	Braking – ABS and ESP	Gain essential knowledge about the operation, maintenance and testing of electronically controlled braking systems, covering both Bosch and non-Bosch variants	21/03/17	2 days
VSG5	Component Diagnosis	Acquire a sound working knowledge of all of the components within a typical engine management system and how to test them.	28/03/17	2 days
VSC28	Steering Geometry	Correctly diagnose alignment faults and propose the appropriate corrective action	06/04/17	1 day
VSG11	Petrol Direct Injection	For technicians already with a good understanding of fuel injection systems (civerevred in VSG2, VSG5, VSTD9). Advance your ability to diagnose and repair petrol system running faults and components	11/04/17	2 days

FULL COURSE DESCRIPTIONS AND NATIONWIDE SCHEDULES AVAILABLE AT THE BRANCH

PICOSCOPE OSCILLOSCOPE TRAINING COURSE*

COMING SOON

A 5-step training programme developed with Picoscope covering the full range of capabilities of the little blue box in your drawer. From the basics of "why do I need an Oscilloscope" and simply connecting and setting up, through using the maths channels, to expanding the 'scope to measure pressure, noise and vibration.

The steps covered are:

1. **Oscilloscope Diagnostics a Picoscope Guide:** Introduction to oscilloscopes
2. **Starting Scope Diagnostics:** Getting a new user comfortable using the Picoscope
3. **Advance Scope Diagnostics:** Looking at the more advanced features
4. **Pressure Testing:** using the WPS500X for all pressure applications
5. **Noise & Vibration Testing:** Analyzing Noise, Vibration and Harshness measurements.

CALL THE BRANCH FOR THE LATEST NEWS ON COURSE DATES

*External courses are not included within the Euro Academy Membership entitlement and are charged separately.

*Finance example typically based on a 5 year lease purchase agreement. Finance subject to status, full terms and conditions available on request. Other finance options available. All prices exclude VAT at 20%. Price, availability and specification may change without prior notice. Warranty subject to manufacturers terms and conditions of use. Errors and omissions excluded. Offers valid until 31st March 2017. Prices correct at time of going to press: December 2016.

SETTING UP FOR MOT TESTING

Before you can carry out MOT testing you need an MOT Manager to run the test centre and an MOT Tester approved for the vehicle classes you want to test. Both the MOT Manager and MOT Tester must have passed their respective DVSA approved courses, which are available through the Euro Academy.

MOT NATIONAL TESTER TRAINING COURSE

Level 2 Award in MOT Testing

All new MOT testers are now required to complete the Level 2 Award in MOT Testing for their relevant vehicle class. This is a lifetime qualification. You will be considered professionally competent for the rest of your life, subject to completing an Annual Assessment to maintain your testing status.

There are two Awards in MOT Testing available depending on your vehicle class:

- Level 2 Award in MOT Testing (Classes 1 and 2)
- Level 2 Award in MOT Testing (Classes 4 and 7)

The Level 2 Award in MOT Testing includes:

- Safe working practices within Testing Centres
- Communicating with colleagues and customers
- How to manage professional development as an MOT tester
- How to carry out pre-test checks
- How to carry out the MOT test.

This 5-day course includes eight hours practical training. You will complete an entire simulated, uninterrupted MOT test for the relevant vehicle class in a training environment that meets the DVSA's requirements. There will be an externally set and marked examination which will test the knowledge you have gained.

ONLY **£895.00**



MOT SITE MANAGER TRAINING COURSE

Level 3 Award in MOT Test Centre Management

All new MOT Test Centre Managers are now required to complete a Level 3 Award in MOT Test Centre Management. This is a lifetime qualification, with no continuous professional development required.

The qualification will cover:

- Managing the legislative and compliance requirements of a Vehicle Testing Station
- Dealing with customer service problems and complaints
- Developing and supervising staff within a test centre
- Test centre quality systems and audits.

During the 2-day course you will receive practical training and will be assessed through an online multiple choice examination.

ONLY **£795.00**

**ASK YOUR LOCAL BRANCH
FOR A COURSE SCHEDULE**

MOT CPD ASSESSMENTS

Qualified MOT testers no longer need to attend a 5-year refresher course. Instead, they must complete the new MOT annual training and assessment to maintain their testing status. The Euro Academy/ IMI online learning module and assessment satisfies the DVSA requirements. Simply purchase your login and password to access a three-hour program and assessment – this is available for Motor Cycle class 1 and 2 testers as well as class 3,4,5 and 7 vehicle testers. All testers must complete their assessment by March 31st 2017 to remain qualified.

263 00 0010

ONLY **£56.99**

*Finance example typically based on a 5 year lease purchase agreement. Finance subject to status, full terms and conditions available on request. Other finance options available. All prices exclude VAT at 20%. Price, availability and specification may change without prior notice. Warranty subject to manufacturers terms and conditions of use. Errors and omissions excluded. Offers valid until 31st March 2017. Prices correct at time of going to press: December 2016.

MOT BRAKE TESTERS

CALL FOR A QUOTE

Replacing a worn-out brake tester that is continually letting you down or becoming increasingly expensive to repair will not just bring outgoings back under control. It will bring with it the opportunity to take advantage of technological advancements e.g. wireless tablet controls.

- MOT or ATL
- Class I&II (motorcycle), IV, VII, HGV
- Analogue or PC displays

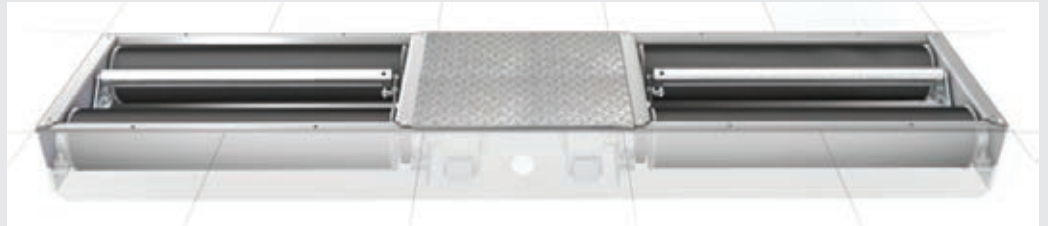

MOT BRAKE TESTERS

(2 person testing)

WEEKLY FROM ONLY **£35.25⁺**
FROM ONLY **£6,995.00**

ATL BRAKE TESTERS

WEEKLY FROM ONLY **£38.28⁺**
FROM ONLY **£7,595.00**



HEADLAMP TESTERS

Also available in a 'service' version for pre-MOT preparation. The DVSA approved headlight beam tester come in two options: mirror visor (analogue), or laser (digital). They are supplied with a standard length of rails, (additional rail lengths are available as a further option). Engineer installation is included to a prepared sites.

ANALOGUE HEADLAMP TESTER

(including installation)
586 77 0130

ONLY **£845.00**

LASER HEADLAMP TESTER

(including installation)
586 77 0150

ONLY **£995.00**

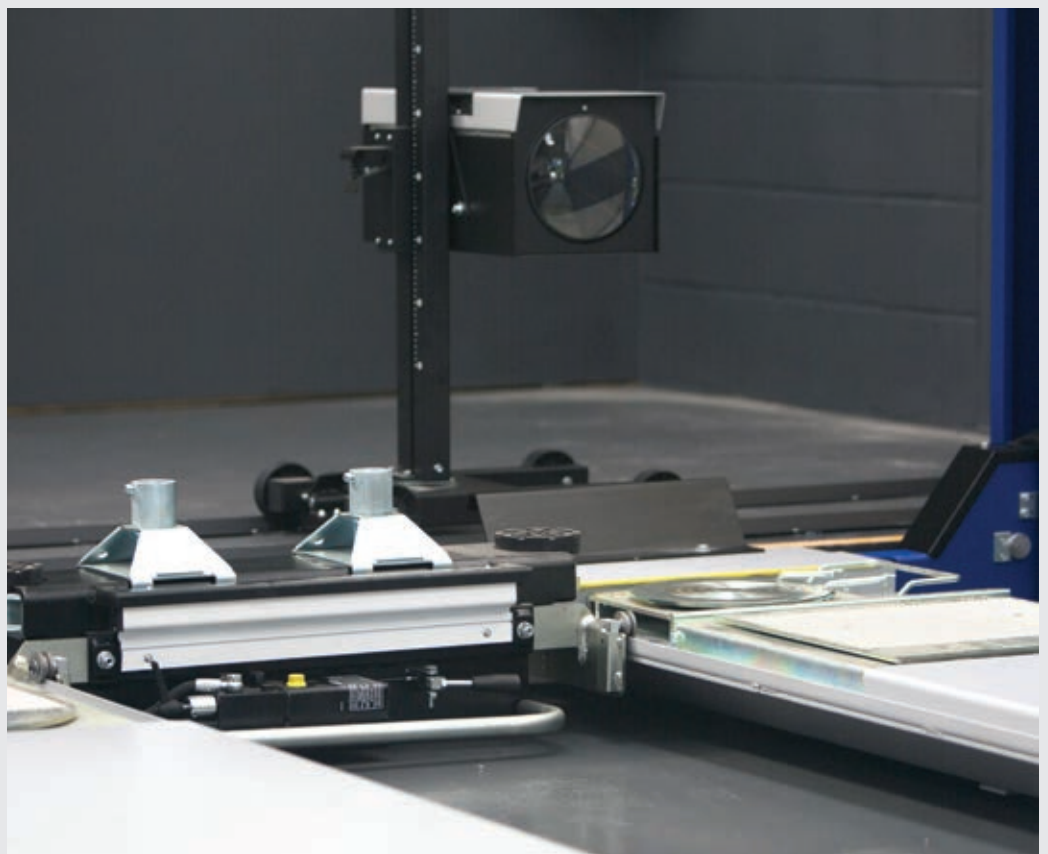

*Finance example typically based on a 5 year lease purchase agreement. Finance subject to status, full terms and conditions available on request. Other finance options available. All prices exclude VAT at 20%. Price, availability and specification may change without prior notice. Warranty subject to manufacturers terms and conditions of use. Errors and omissions excluded. Offers valid until 31st March 2017. Prices correct at time of going to press: December 2016.

MOT LIFTS

For a two-person test lane, replacing an old or worn out MOT lift is an opportunity to improve your profitability from two person to one person testing, by also upgrading the brake tester to ATL capability.

- Available for Class IV, VII, HGV
- Available in different dimensions and platform lengths to fit existing recesses
- Available in 4 Post, or Scissor design
- Available with Secondary platforms – no need for jacking beams



CALL FOR A QUOTE

4 POST CLASS IV MOT LIFT (2 person testing)

WEEKLY FROM ONLY **£49.37⁺**
FROM ONLY **£9,795.00**

4 POST CLASS IV ATL LIFT (1 person testing)

WEEKLY FROM ONLY **£66.00⁺**
FROM ONLY **£13,095.00**

4 POST CLASS IV OPTL UPGRADE (ATL Lift + Braketester)

WEEKLY FROM ONLY **£90.19⁺**
FROM ONLY **£17,895.00**

DUAL REVENUE LIFTS

Replacing an old or worn out MOT or ATL lift is an opportunity to bring dual-revenue capability, and turn MOT testing downtime over to making money from Alignment.

- Available for Class IV, VII, HGV
- Available in 4 Post, or Scissor design
- Available with Secondary platforms – no need for jacking beams

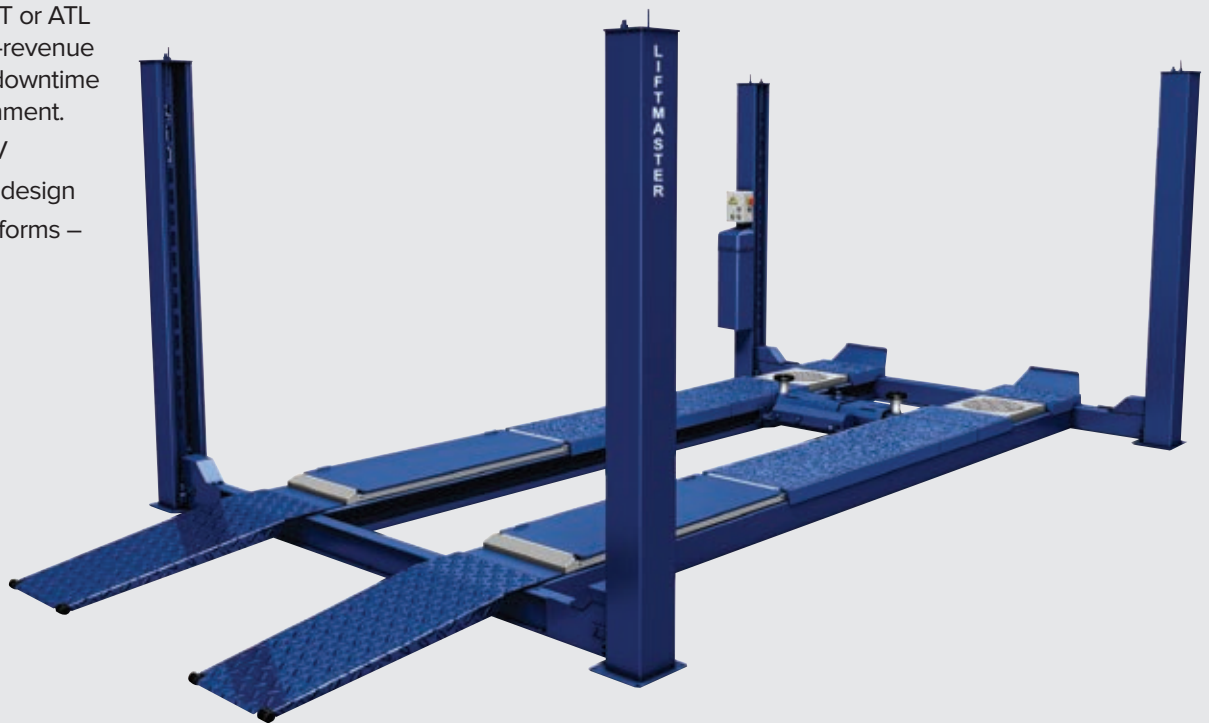

CALL FOR A QUOTE

4 POST CLASS IV ATL DUAL REVENUE LIFT

WEEKLY FROM ONLY **£56.93⁺**
FROM ONLY **£11,295.00**

FULL RANGE OF ALIGNMENT SYSTEMS AVAILABLE

*Finance example typically based on a 5 year lease purchase agreement. Finance subject to status, full terms and conditions available on request. Other finance options available. All prices exclude VAT at 20%. Price, availability and specification may change without prior notice. Warranty subject to manufacturers terms and conditions of use. Errors and omissions excluded. Offers valid until 31st March 2017. Prices correct at time of going to press: December 2016.

MOTORCYCLE MOT TESTING

RSW Equipment is the UK's most popular motorcycle MOT testing equipment. The Brake Tester has been designed to comfortably test the brakes of all motorcycles and scooters regardless of size. Readings are taken from a wall mounted remote console, ensuring complete freedom from obstruction in the testing area.

- Includes automatic weighing scale
- Supplied with user-friendly infra-red remote control handset to command the operation
- Combination of analogue and digital display provides valuable diagnostic information relevant to brake performance such as drum/disc run out.
- Full operator training provided on installation
- Operates on 1ph supply

Ideal as a standalone bay, or can be added on to an existing class IV or VII bay (all proposals and installations subject to approval by DVSA)

ASK FOR A SITE SURVEY TODAY!



MOTORCYCLE MOT ADD-ON TO AN EXISTING BAY

WEEKLY FROM ONLY **£7.53⁺**
FROM ONLY **£1,495.00**

STANDALONE MOTORCYCLE MOT PACKAGE

WEEKLY FROM ONLY **£39.29⁺**
FROM ONLY **£7,795.00**

MOT PIT PACKAGES

An MOT Pit Lane is the package to consider for garages with height restrictions*.

MOT Pit Testing Equipment is available in Standard (2 person testing), and ATL configurations for Class IV, Class VII, and HGV testing.

CALL FOR A QUOTE

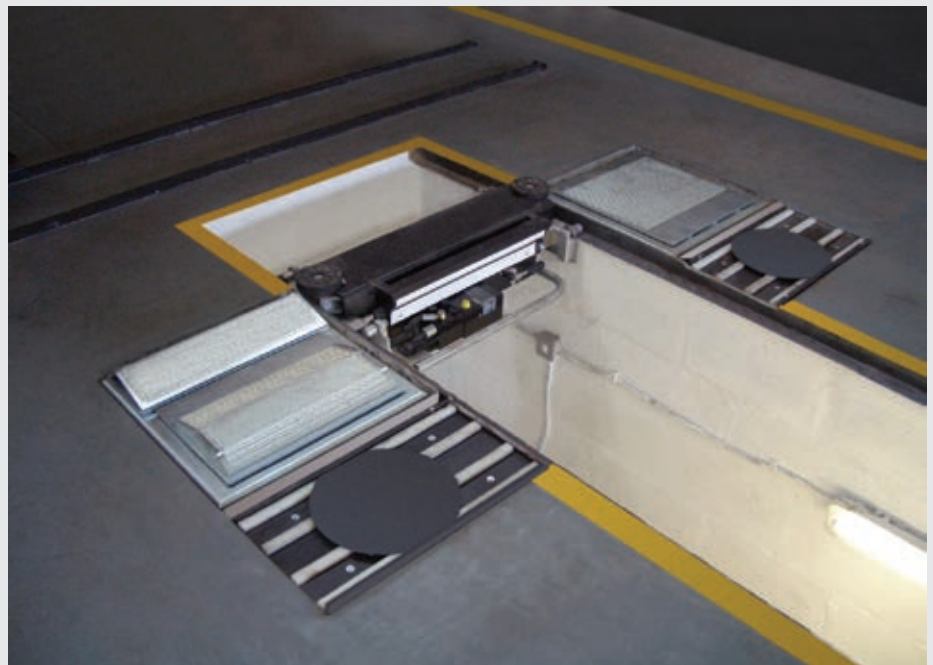

CLASS IV MOT PIT PACKAGE

(2 person testing)

WEEKLY FROM ONLY **£44.07⁺**
FROM ONLY **£8,745.00**

*Equipment price above does not include cost of civil works to prepare, or install a prefabricated pit. If a pit is required, our Projects Team can look after this from scratch, and will provide a quote as applicable to your requirements. Please call the branch to arrange a site visit.

*Finance example typically based on a 5 year lease purchase agreement. Finance subject to status, full terms and conditions available on request. Other finance options available. All prices exclude VAT at 20%. Price, availability and specification may change without prior notice. Warranty subject to manufacturers terms and conditions of use. Errors and omissions excluded. Offers valid until 31st March 2017. Prices correct at time of going to press: December 2016.

BRADBURY CLASS IV & VII 4-POST LIFT, SCISSOR LIFT & PIT LANE PACKAGES

The largest range of lift platforms and lengths available!

- Driver side controls
- Safe and reliable hydraulic operation
- Anti tilt system
- 5 year structural guarantee
- FREE Brake Tester Cassette Frame included
- Tablet-operated as standard

CHOOSE FROM

- Pit Package
- 4 Post Package
- Scissor Package
- Hybrid Lift Package

4 POST PACKAGE
WEEKLY FROM ONLY **£104.23⁺**
FROM ONLY **£20,680.00**



WERTHER CLASS IV & VII 4-POST LIFT PACKAGES

- Brake Tester with cover plates
- Wheel play detectors and integrated LED torch
- Turntables Headlight, Aligner, Jacking Beam, Mirrors
- Site survey and CAD drawings
- 1 Year warranty
- FREE Brake Tester Cassette Frame included

The new Werther range of roller brake testers is a new class of high quality, high performance equipment, updated to the highest requirements and standards. The robustness of the components makes these brake testers built to last



4 POST PACKAGE
WEEKLY FROM ONLY **£100.77⁺**
FROM ONLY **£19,995.00**

*Finance example typically based on a 5 year lease purchase agreement. Finance subject to status, full terms and conditions available on request. Other finance options available. All prices exclude VAT at 20%. Price, availability and specification may change without prior notice. Warranty subject to manufacturers terms and conditions of use. Errors and omissions excluded. Offers valid until 31st March 2017. Prices correct at time of going to press: December 2016.

Tecalemit is among the UK's longest established suppliers of MOT Testing equipment, offering the most comprehensive range of technically advanced VOSA approved equipment. Each principal item of equipment has been developed to provide time saving features to ensure that the test lane operates at optimum output.

TAKE A LOOK AT WHAT YOU GET!



STANDARD CLASS IV 4 POST PACKAGE COMES WITH

4 Ton 4.3m Elec/Hyd Lift, with flush fitting play detector and radius plates, 2T manual jacking beam, Single bed electronic car brake tester – wall mounted display, Headlamp beam tester, Pair of convex mirrors inclusive of installation, Brake pedal applicator

STANDARD CLASS VII 4 POST PACKAGE COMES WITH

4 Ton 5.2m Elec/Hyd Lift, with flush fitting play detector and radius plates, 3T manual jacking beam, LGV brake tester – wall mounted display, Headlamp beam tester, Pair of convex mirrors inclusive of installation, Brake pedal applicator, rail extensions
5.7 & 6.5m options available

4 POST PACKAGE

WEEKLY
FROM ONLY **£108.33⁺**
ONLY **£21,495.00**

EMISSION UPGRADE AVAILABLE

TECALEMIT TGD/MDS COMBINED EMISSION TESTER

- Only one calibration per year on both petrol and diesel
- DVSA approved for all classes of MOT testing
- Mobile cabinet
- PC operating platform
- Integral DiSpeed 492 engine RPM measurement
- 1 year manufacturer's warranty

SUPPLIED WITH ATL PACKAGE

588 01 0170
WEEKLY
FROM ONLY **£19.40⁺**
ONLY **£3,850.00**

STANDALONE PRICE

588 01 0160
WEEKLY
FROM ONLY **£26.96⁺**
ONLY **£5,350.00**



*Finance example typically based on a 5 year lease purchase agreement. Finance subject to status, full terms and conditions available on request. Other finance options available. All prices exclude VAT at 20%. Price, availability and specification may change without prior notice. Warranty subject to manufacturers terms and conditions of use. Errors and omissions excluded. Offers valid until 31st March 2017. Prices correct at time of going to press: December 2016.

DVSA APPROVED 4-POST LIFT, SCISSOR LIFT & PIT LANE ATL PACKAGES FOR CLASSES IV & VII

See it before you buy it. Scan here.



All Crypton ATL Packages include:

- Quality checker plate surface for maximum protection against corrosion
- Combined Gas & Smoke Emissions Analyser (see page 18)
- Automated Brake Tester with Galvanised Cover Plates (Optional motorcycle and 4x4 adaptors available)
- Full range of ATL components as per image
- Site survey & CAD drawings
- 3 year warranty: Parts & Labour

3 YEARS WARRANTY



Optional: Revolutionise your MOT bay with a robust 10" Wireless Tablet for complete flexibility & efficient testing.

- Enter results onto the DVSA system online as you move around the MOT bay
- Operate the emissions test via the tablet
- Operate the brake tester from inside the vehicle
- No need to return to the workstation
- Print results wirelessly
- Complete with tablet case, WiFi dongle, network cable & product support



Separate internet connection must be available and is not included as part of the package.

TABLET
588 77 034P ONLY **£499.00⁺**
(includes engineer visit)

PIT PACKAGE
WEEKLY
FROM ONLY **£90.71⁺**
FROM ONLY **£17,999.00**

FREE MOT BANNER
WITH ANY CRYPTON ATL PACKAGE



*Finance example typically based on a 5 year lease purchase agreement. Finance subject to status, full terms and conditions available on request. Other finance options available. All prices exclude VAT at 20%. Price, availability and specification may change without prior notice. Warranty subject to manufacturers terms and conditions of use. Errors and omissions excluded. Offers valid until 31st March 2017. Prices correct at time of going to press: December 2016.

**ASK ABOUT OUR EXTENDED WARRANTY
AND CARE PLANS**



**LIFTMASTER OFFERS THE LARGEST RANGE OF ATL OPTIONS –
MAKE NO COMPROMISE ON YOUR LAYOUT PLANS!**

- Dual Revenue ATL/Alignment options on most lifts
- Delivered and installed by the same team
- Exceptional Warranty back-up with the Lifetime Rolling Warranty option
- FREE Brake Tester Cassette included

UPGRADE OPTIONS:

- Wireless Tablet
- Dual Revenue (ATL + Alignment) 4 Post or Scissor Lifts
- Motorcycle Testing
- 4 Post Lift
- Scissor Lift
- Secondary Platform Lift

PIT PACKAGE: Hydraulic Play Detectors; Turning Plates; Manual Jacking Beam; computer-controlled Roller Brake Tester with integrated weighing; rail-mounted Headlamp Aligner
4 Post or Scissor Lift Package: Vehicle Lift with integrated Turning Plates; Manual Jacking Beam; computer-controlled Roller Brake Tester with integrated weighing rail-mounted Headlamp Aligner

As specialists on vehicle lifts and MOT testing equipment, Liftmaster's equipment sourcing policy is based on quality above all else. A Liftmaster ATL package is brought together from products made by the leading UK and European manufacturers in their field. This focus on quality equipment, coupled with the training, experience and skill of Liftmaster's own engineers is what gives Liftmaster the confidence to back the equipment with the unique Rolling Warranty offer for the service lifetime of the equipment.

WEEKLY **£83.13⁺**
 FROM ONLY
PIT PACKAGE FROM ONLY £16,495.00

*Finance example typically based on a 5 year lease purchase agreement. Finance subject to status, full terms and conditions available on request. Other finance options available. All prices exclude VAT at 20%. Price, availability and specification may change without prior notice. Warranty subject to manufacturers terms and conditions of use. Errors and omissions excluded. Offers valid until 31st March 2017. Prices correct at time of going to press: December 2016.

The Workshop Solutions Projects team are ready and able to handle anything and everything, from the installation of a single piece of kit, through to replacement of out-dated machines, up to a full installation of all Workshop Equipment into a new or existing building. Anything that's a little out of the ordinary and requires the coordination of numerous different services is food and drink to them. They can provide a full consultation, planning and installation service if that's what you need and their experience with MOT Testing stations is second to none.

In order to keep costs to a minimum while maintaining the highest possible installation standards, they employ a very carefully selected network of experienced sub-contractor engineers to carry out all their

installs and projects nationwide. But they stay in control; everything is managed by them, providing a streamlined, stress free process for our customers, ensuring everything is completed on time, on budget and to very high standards.

Right from the very start, when they begin talking through your idea, their vast experience will shine through. Using their knowledge of the state-of-the-art and most up-to-date practices, combined with experience of what actually works, they might just offer fresh suggestions and solutions to save you money and make your project more profitable.

So, if you think MOT testing might be for you, or you just want to review your existing facility, before you do anything else, give us a call.

PROJECT MANAGEMENT



Our Projects team will live and breathe your project

CIVIL WORKS



Encompassing all the reconfiguring or alterations that you might need on your way

WORKSHOP LIGHTING



Energy-efficient LED lighting systems which can be tailored to your specific requirements

FLOORS



Seamless finishes, dust-proof, anti-slip, high-chemical-resistance and heavy-duty wearing floors

EXTRACTION



Vehicle exhaust extraction for cars, trucks, fire trucks, ambulances, and other emergency vehicles

AIR PIPEWORK



Design and installation of a compressed air ring main which is in sync with the way you want to organise your workflow

Call us now on 0845 603 3636 – One call for complete peace of mind

*Finance example typically based on a 5 year lease purchase agreement. Finance subject to status, full terms and conditions available on request. Other finance options available. All prices exclude VAT at 20%. Price, availability and specification may change without prior notice. Warranty subject to manufacturers terms and conditions of use. Errors and omissions excluded. Offers valid until 31st March 2017. Prices correct at time of going to press: December 2016.

0845 603 3636
OVER 200 BRANCHES NATIONWIDE

OUR SPECIALIST EQUIPMENT SERVICE AND MAINTENANCE TEAM PROVIDES ALL INSTALLATION, SERVICING AND MOT CALIBRATION REQUIREMENTS INCLUDING PLANNED MAINTENANCE AND SCHEDULING



SPECIAL OFFER – GET YOUR AIRCON MACHINE SERVICED AT THE SAME TIME AS YOUR BOSCH OR CRYPTON EMISSIONS CALIBRATION FOR ONLY £ 150 PLUS PARTS!*

*offer applies only to Bosch or Crypton emissions analysers

PLANNED MAINTENANCE

A preventative maintenance contract can provide a significant reduction in repair costs, ensuring total peace of mind for both the equipment owner and operator. Alternatively, services can be secured on 'as required' basis.

PLANNED MAINTENANCE		FROM
Vehicle Lift Maintenance & Repairs	Single Post, 2 Post, 4 Post, Scissor Lift Servicing and Repair	£45.00*
JACKING BEAM REPAIR		CALL
Air & Oil Pipework	Supply and installation including galvanised steel tube, Transair and John Guest aluminium	CALL
Spraybooth Servicing	Complete spraybooth service including certification and testing	£287.50
Compressor Servicing	Service support for compressed air systems excluding parts	£117.00*
Air Conditioning Machine Servicing	Service support and maintenance facility including repairs, training and F-gas assessments	£205.00
WELDING EQUIPMENT SERVICING		£30.00
Spray Gun Repairs	For a variety of spray guns regardless of manufacturer carried out in fast response time	CALL
Waste Collection	Variety of waste collections for various quantities	CALL

The above prices do not include any parts that may be needed.

BREAKDOWN RESPONSE

Regardless of whether or not we have been maintaining your equipment on a service contract, you can take advantage of our prompt breakdown repair service. We understand the urgency of the situation and will dispatch most efficiently.

BREAKDOWN RESPONSE		FROM
Vehicle Lifts call out and repair	2 Post, 4 Post, Scissor Lift	£120.00
Air Conditioning Machine call out and repair	All Makes call out and repair	£75.00
Welding Equipment repair	Spot and Mig Welders, Plasma Cutters, Induction Heaters, TKR Riveters, Oxy/Acet Equipment, Dent Pullers	£30.00
Compressors call out and repair	All Makes call out and repair	£102.50

The above prices do not include any parts that may be needed.

CALIBRATION SERVICES

Once you give us your calibration contract, our database tracks when your MOT equipment is due – so your calibration will always be timely. Using only suitably accredited engineers, we aim to minimise equipment down-time.

CALIBRATION SERVICES		FROM
MOT Equipment Calibration	For both Car and Motorcycle equipment	CALL
Wheel Alignment	Alignment Systems calibrations	£200.00
Emission Analyser Calibration	Scheduled calibrations	£330.00
Tools Calibration	For a wide variety of tools including tyre gauge, torque wrench, pressure gauge, paint thickness & tracking sticks	£12.50*
Paint Scales Calibration	All Makes Paint Scales calibration	£75.00

The above prices do not include any parts that may be needed. Minimum charge for tool calibrations, prices above don't include admin or travel fee. Yearly calibration (2 gas, 1 smoke).

CERTIFICATION & TESTING

We will carry out your required inspections and issue the necessary certificates.

CERTIFICATION & TESTING		FROM
LEV Exhaust Ventilation System Test & Certification		£75.00
Spraybooths Smoke Clearance Test & Certification		£56.25
Spraybooths Breathing Air Quality Test		£75.00

*Minimum quantity applies

The above prices do not include any parts that may be needed.

*Finance example typically based on a 5 year lease purchase agreement. Finance subject to status, full terms and conditions available on request. Other finance options available. All prices exclude VAT at 20%. Price, availability and specification may change without prior notice. Warranty subject to manufacturers terms and conditions of use. Errors and omissions excluded. Offers valid until 31st March 2017. Prices correct at time of going to press: December 2016.

Emission Analysers

NO HASSLE WARRANTY

BEST PRICE PROMISE



CRYPTON COMBINED GAS & SMOKE EMISSIONS ANALYSER

- Complies to the latest DVSA regulations
- Enter results on the DVSA online system
- Tests vehicle classes IV, V & VII (Petrol & Diesel)
- Operates the emissions test
- Operates the brake tester (when purchased)
- Housed in a quality mobile cabinet

Includes: 3 Year Parts & Labour Warranty, 23" Colour Screen, Printer, Mouse & Keyboard with Dust/Grease Protector, Oil Temperature Probe, Smoke Meter with automatic calibration, Battery RPM Measurement & Gas Analyser accurate to OIML 0 Class O

Upgrade to 5 Year Extended Care: Parts & Labour, MOT Updates, Calibrations & Routine Consumables

COMBI+ SAVE £200 WHEN YOU PURCHASE WITH A 10" TABLET

- Control the emissions via tablet
- Operate the brake tester from inside the vehicle
- Enter results (incl. MOT) onto the DVSA online system
- No need to return to the workstation
- Print results wirelessly
- Complete with tablet case, WiFi dongle, network cable & product support



Tablet: £149 when bought with Combi. **£399** when bought separately.

3 YEARS WARRANTY

CCP800 E WIRELESS
588 01 0070

WEEKLY FROM ONLY **£24.44⁺**
ONLY £4,850.00

CCP800 C CABLE
588 01 0060

WEEKLY FROM ONLY **£21.41⁺**
ONLY £4,249.00

CCP800+ E WIRELESS
with Tablet
588 01 0460

WEEKLY FROM ONLY **£25.19⁺**
ONLY £4,999.00

CCP800+ C CABLE
with Tablet
588 01 0450

WEEKLY FROM ONLY **£22.17⁺**
ONLY £4,399.00

DESCRIPTION	WHAT'S INCLUDED				PART NUMBER	WEEKLY	PRICE
	WARRANTY*	SERVICE	CALIBRATIONS**	VOSA UPDATES			
Crypton CCP800 Combi Analyser – Cable	36m	NO	NO	NO	588 01 0060	£21.41⁺	£4,249
Crypton CCP800 Combi Analyser – Wireless	36m	NO	NO	NO	588 01 0070	£24.44⁺	£4,850
Crypton CCP800+ Combi Analyser – Cable + Tablet	36m	NO	NO	NO	588 01 0450	£22.70⁺	£4,399
Crypton CCP800+ Combi Analyser – Wireless + Tablet	36m	NO	NO	NO	588 01 0460	£25.79⁺	£4,999
Crypton Emissions – Single Smoke Calibration ONLY 1 Visit	NO	NO	1	NO	588 77 0270	-	£165
Crypton Emissions – Single Gas Calibration ONLY 1 Visit	NO	NO	1	NO	588 77 0280	-	£185
Crypton Combi Calibration Annual Contract**	NO	NO	2 + 1	YES	588 77 0200	-	£360
Crypton Combi 3 YEAR Care Plan available only at point of sale	36m	Callout, labour and parts (including consumables but not peripherals)	6 + 3	YES	263 77 0910	£7.55⁺	£1,499
Crypton Combi 5 YEAR Care Plan available only at point of sale	60m	Callout, labour and parts (including consumables but not peripherals)	10 + 5	YES	263 77 0920	£15.72⁺	£3,120

* Subject to Manufacturer's Terms & Conditions of use

** VOSA mandates that a gas (petrol) bench is calibrated every 6 months, and a smoke (diesel) every 12 months. There for a combined analyser annual calibration contract is 2 gas and 1 smoke calibration.

*Finance example typically based on a 5 year lease purchase agreement. Finance subject to status, full terms and conditions available on request. Other finance options available. All prices exclude VAT at 20%. Price, availability and specification may change without prior notice. Warranty subject to manufacturers terms and conditions of use. Errors and omissions excluded. Offers valid until 31st March 2017. Prices correct at time of going to press: December 2016.

0845 603 3636
OVER 200 BRANCHES NATIONWIDE

PREMIER COMBI ANALYSER

Exclusive from Workshop Solutions – full 3 years warranty, parts and labour, covering all major parts including PC, Gas Bench, Smokehead, Printer, Monitor, Keyboard and Mouse, plus 3 years calibrations as standard. Save up to £1000.

British built combined petrol and diesel emission analyser with integrated oil temperature and unique RPM measurement technology.

- Every MOT test is stored to memory for instant retrieval and automatic printout of customer reminder letters
- Wi-Fi enabled PC with flexibility to run own programmes, CD Rom, 17" colour monitor, keyboard, mouse and printer
- Cable-less smokehead is Euro 6 compliant for a future-proofed investment
- Fast nationwide on-site support by dedicated UKAS accredited engineers
- Each Premier Combi is given at least 90 hour run testing before delivery
- EOBD, RPM, and Oil Temperature Kit are fully compliant to latest DVSA guidelines
- 3 years Care Package included
- British designed and manufactured

WITH 3 YEARS CARE PACK

588 01 0200

WEEKLY FROM ONLY **£25.17***
ONLY **£4,995⁰⁰**

WITH 1 YEARS CARE PACK

588 01 0280

WEEKLY FROM ONLY **£21.90***
ONLY **£4,345⁰⁰**

PREMIER COMPACT

Already have a modern PC brake tester? Want the analyser dedicated to the testlane? Save money and space with the Premier Compact! (subject to compatibility with existing brake tester PC).

P.O.A.

DESCRIPTION	WHAT'S INCLUDED				PART NUMBER	WEEKLY	PRICE
	WARRANTY*	SERVICE	CALIBRATIONS**	VOSA UPDATES			
Premier Compact with 1 Year care pack	12m	Callout, labour and parts (including peripherals and consumables)	2 + 1	YES	588 01 0260	P.O.A.	
Premier Compact with 3 Year care pack	36m	Callout, labour and parts (including peripherals and consumables)	6 + 3	YES	588 01 0270	P.O.A.	
Premier Combi analyser with 1 Year care pack	12m	Callout, labour and parts (including peripherals and consumables)	2 + 1	YES	588 01 0280	£21.90*	£4,345
Premier Combi analyser with 3 Year care pack	36m	Callout, labour and parts (including peripherals and consumables)	6 + 3	YES	588 01 0200	£25.17*	£4,995
Calibration Only Annual contract** available after completion of original Care Pack term	NO	NO	2 + 1	NO	588 77 0290	-	£433
1 Year Care Plan on-going after completion of original Care Pack term	12m	Callout, labour and parts (including peripherals and consumables)	2 + 1	NO	588 77 0310	-	£780

* Subject to Manufacturer's Terms & Conditions of use

** VOSA mandates that a gas (petrol) bench is calibrated every 6 months, and a smoke (diesel) every 12 months. There for a combined analyser annual calibration contract is 2 gas and 1 smoke calibration.

*Finance example typically based on a 5 year lease purchase agreement. Finance subject to status, full terms and conditions available on request. Other finance options available. All prices exclude VAT at 20%. Price, availability and specification may change without prior notice. Warranty subject to manufacturers terms and conditions of use. Errors and omissions excluded. Offers valid until 31st March 2017. Prices correct at time of going to press: December 2016.

NO SPACE FOR A SEPARATE ALIGNMENT BAY?

Why not utilise your MOT bay when it's quiet with a 3D alignment upgrade. Generate more profit with a relatively small-scale add-on to the MOT lift, along with a 3D alignment system. Workshop Solutions can offer more lift and alignment options than anyone else. Talk to us to explore your options today.



Upgrade an existing lift to 3D Alignment using the equipment below or a similar combination. There is even a kit to support 3D alignment on a 2 Post lift!

PRODUCT	DESCRIPTION	PRICE
Pair of Mechanical Turnplates	For front or rear axle adjustment, or both. Sits on or within recesses on Lift platform.	£550
Portable Rear Slip Plates	For rear axle adjustment. Used in some systems rather than rear turnplates – 300mm square	£140
A Pair of Run up Ramps/Roll-back Kit	To allow the vehicle to roll on and off turnplates/slip plates if above the platform surface	£140
Pack 1 Kit for customers without alignment lift	Kit to convert a Service Lift to Alignment, consists of front 'housing' with drive-on ramps to accommodate turnplates, additional turplates for rear, and rear 'housing' with drive on/ drive off ramps	£1,295
Pack 2 Kit for customers without alignment lift	Kit to convert a Service Lift to Alignment, consists of front 'housing' with drive-on ramps to accommodate turnplates including extended platform for 'roll-back, and with drive on/ drive off ramps	£2,795
Pack 3 Kit for customers without alignment lift	Kit to convert a Service Lift to Alignment, consists of front 'housing' with drive-on ramps to accommodate turnplates	£895
Alignment Tables	Kit to allow 4 wheel alignment on a 2 post lift. Consists of 4 tables. Max weight 3000kg across 4 tables	£895

For guidance only. The upgrade required depends on the existing equipment and the intended Alignment system. Ask our Workshop Equipment Specialist for a quote. 3D Alignment System also required.

ALIGNMENT LIFTS

The advantage of a purpose-built alignment lift is all components matching and optimised to each other. Choose your aligner and lift combination from the below and the preceding pages. Workshop Solutions can offer more aligner-and-lift combinations than anyone else. Talk to us to explore your options

MODEL	DESCRIPTION	PART NUMBER	WEEKLY	PRICE
Bendpak HDS14LSX	6350Kg capacity 5054mm platforms inc. turnplates & rear slip plates 1 or 3 phase	578 77 0090	£32.13*	£6,375
Bendpak HDS14LSXE	6350Kg capacity 5816mm platforms inc. turnplates & rear slip plates 1 or 3 phase	578 77 0000	£34.65*	£6,875
Werther 450AT	4000Kg capacity 5000mm platforms with front recesses & rear slip plates 3 phase	578 77 0220	£32.13*	£6,375
John Bean EELR575A	4000Kg capacity 5200mm platforms with front recesses & rear slip plates 3 phase – 2 years warranty	578 77 0410	£38.28*	£7,595

ASK FOR ADVICE FROM OUR WORKSHOP EQUIPMENT SPECIALIST

*Finance example typically based on a 5 year lease purchase agreement. Finance subject to status, full terms and conditions available on request. Other finance options available. All prices exclude VAT at 20%. Price, availability and specification may change without prior notice. Warranty subject to manufacturers terms and conditions of use. Errors and omissions excluded. Offers valid until 31st March 2017. Prices correct at time of going to press: December 2016.

HOFMANN MEGALINE 4 – WALL MOUNTED OR TROLLEY LASER ALIGNMENT SYSTEM

Proven highly profitable, and technically valuable tool. Capable of individual front and rear toe, rear thrust line, set back and steering wheel position. A must for any garage or tyre shop.

- Simple, speedy 'hang-on' heads
- Laser accuracy
- Handles rims up to 23"
- Supplied with necessary accessories
- Low cost means fast return on investment



SYSTEM 4WE – WALL MOUNTED WITHOUT LIGHTBOX

587 77 1330

WEEKLY FROM ONLY **£9.80⁺**
ONLY **£1,945.00**

SYSTEM 4T – PORTABLE TROLLEY

587 77 0040

WEEKLY FROM ONLY **£12.57⁺**
ONLY **£2,495.00**

SYSTEM 4W – WALL MOUNTED

587 77 1320

WEEKLY FROM ONLY **£10.05⁺**
ONLY **£1,995.00**

JOHN BEAN A300/A350

Wall-mounted or Trolley mounted Laser Aligner to suit as required

- Wheel rims – 12 inches to 23 inches
- Alloy friendly clamp contact
- Turn plates included
- Continual operation up to 8 hours
- 2 Year warranty



A300 LASER WHEEL ALIGNER – WALL MOUNT

587 77 0300

WEEKLY FROM ONLY **£10.46⁺**
ONLY **£2,075.00**

A350 LASER WHEEL ALIGNER – TROLLEY MOUNT

587 77 0310

WEEKLY FROM ONLY **£12.07⁺**
ONLY **£2,395.00**



LITE ALIGN 450 WALL MOUNTED

587 77 0020

Wall mounted car and light commercial four wheel laser aligner kit. Includes two front laser heads, two rear flag units, brake pedal depressor, steering clamp, turn discs, wall mount rack and 100mm rim buttons

MEASURES:

- Front and rear individual and total toe, to ensure correct tracking and stability on the road
- Thrust Line, to make sure the rear wheels are pointing in the straight ahead position in relation to the centre line of the vehicle
- Set back, to check front and rear wheels to ensure correct alignment across the vehicle
- Corrects steering wheel alignment. Rear flags enable the end user to adjust the alignment to achieve perfect steering wheel alignment first time.

KEY FEATURES:

- Unique tyre/wheel mounting system, resulting in more accurate measurement, reduced risk of heads becoming detached during adjustments
- Rechargeable battery operation, no cables
- Fits 12 to 22 inch wheels, cars and light commercials, XL kit available for larger wheels
- Optional digital Camber/Caster/SAI gauge available

WEEKLY FROM ONLY **£7.79⁺**
ONLY **£1,545.00**

LITE ALIGN 450 WALL MOUNTED WITH MAGNETIC CASTER CAMBER GAUGE

587 77 0640

Wall mounted car and light commercial four wheel laser aligner with magnetic caster camber gauge. Includes two front laser heads, two rear flag units, brake pedal depressor, steering clamp, turn discs, wall mount rack and 100mm rim buttons.

WEEKLY FROM ONLY **£9.55⁺**
ONLY **£1,895.00**

*Finance example typically based on a 5 year lease purchase agreement. Finance subject to status, full terms and conditions available on request. Other finance options available. All prices exclude VAT at 20%. Price, availability and specification may change without prior notice. Warranty subject to manufacturers terms and conditions of use. Errors and omissions excluded. Offers valid until 31st March 2017. Prices correct at time of going to press: December 2016.

HOFMANN MEGAPLAN ECOLINE 58/88 – FULLY COMPUTERISED WHEEL ALIGNMENT WITH A4 PRINTER

Bridging the gap between laser alignment and fully computerised systems with printout, which traditionally made the jump too big for many workshops.

Ecoline 58 and 88 are supplied with a comprehensive vehicle database from the recognised industry name, Autodata, and offers a before and after printout. The Ecoline series – is the logical choice for anybody wanting to move into advanced vehicle geometry without the cost traditionally associated with computerised systems.

Only one alignment a week turns this investment into profit!

ECOLINE 58/88 FEATURES

- Simple to use – faster readings, saves time increasing your profit
- Supplied with PC, 19" monitor – clear impressive graphics with onscreen instructions
- Onsite training – your machine, your premises Hofmann Megaplan's specialists
- Comprehensive Vehicle Database by Autodata – over 17,000 models from 80 manufacturers
- A4 Printer – Provides before and after readings for customers
- Traditional 4-Point Clamps (58 only) – handles up to 23" rims as standard
- Front Cameras and Rear Sensors – increases accuracy and repeatability
- Zigbee® wireless communication – offers stronger and more reliable signal over Bluetooth®

ECOLINE 88 ONLY FEATURES

- 3 Point 'Grab Clamps' – even faster mounting, saves more time
- Front & Rear Cameras – ideal for advanced geometry when speed is needed



ECOLINE 58
587 77 1340

WEEKLY FROM ONLY **£20.64⁺**
ONLY **£4,095.00**

ECOLINE 88
587 77 1270

WEEKLY FROM ONLY **£27.69⁺**
ONLY **£5,495.00**

JOHN BEAN PRISM ELITE

The Visualiner Prism Elite allows you to add alignment to your garage services without needing to hire an experienced alignment technician.

Plus, not only will you be able to pinpoint alignment problems, it generates reports that can be shared with customers, which is why your alignment business will start growing from day one.

If you already own a John Bean Geogas 3000 or 5000 Emissions Analyser, you can add a Prism kit to this unit – saving you space in your workshop and allowing your MOT bay to carry out alignments.

Computerised wheel alignment with Pro 42 software.

- Accurate, flexible and easy to service
- Perform alignments quickly from virtually anywhere in the workshop
- Integrated help system
- Extensive manufacturers' specification database

SHARING THE GEOGAS PC
587 77 1130

WEEKLY FROM ONLY **£30.21⁺**
ONLY **£5,995.00**

STANDALONE PRICE
587 77 0570

WEEKLY FROM ONLY **£34.50⁺**
ONLY **£6,845.00**



*Finance example typically based on a 5 year lease purchase agreement. Finance subject to status, full terms and conditions available on request. Other finance options available. All prices exclude VAT at 20%. Price, availability and specification may change without prior notice. Warranty subject to manufacturers terms and conditions of use. Errors and omissions excluded. Offers valid until 31st March 2017. Prices correct at time of going to press: December 2016.

JOHN BEAN ELS 3D ALIGNMENT SYSTEM WITH TILTING CAMERA

587 77 1730

The new John Bean 3D ELS alignment system has a tilted camera boom for flexible vehicle positioning, eliminating the need for a fixed position to carry out alignment checks and being able to position the camera at the touch of a button.

Running the Pro 32 software application, the ELS saves space in the workshop because everything is mounted on the support post.

The vehicle orientation directional indicator guides the technician when they are unable to see the screen, while interchangeable grippers on the wheel clamps assist work on different wheel types within a clamping range of 11" rims to 22" rims.

- AC 100 rim clamps, with a clamping range 11" – 22" rims
- Compact design everything mounted on the support post
- Tilting camera boom for working at different heights
- 3D technology for fast and accurate measurements
- Vehicle database included

SPACE SAVING DESIGN

NEW

WEEKLY FROM ONLY **£32.73⁺**
ONLY **£6,495.00**



JOHN BEAN V2200 & V2300

Offer advanced alignment service to your customers without needing specialised wheel alignment technicians.

Computerised 3D car wheel alignment with Pro 42 software for general repair shops. Liftable two-camera beam and 22" TFT flatscreen monitor. Cordless communication between targets and HD camera system.

V2200

- Comprehensive and up-to-date manufacturers' specifications
- Versatile wheel clamps provide a solid and worry-free attachment with a patented positioning procedure.
- Take a full four-wheel alignment reading in minutes.

V2300

Features as for V2200 plus

- Measurement of toe, camber, caster, maximum steering angle, rolling radius and cross diagonal
- EZ Access for measurement with demounted wheels

JOHN BEAN V2200

587 77 0050

WEEKLY FROM ONLY **£44.10⁺**
ONLY **£8,750.00**

JOHN BEAN V2300

587 77 0060

WEEKLY FROM ONLY **£65.49⁺**
ONLY **£12,995.00**



*Finance example typically based on a 5 year lease purchase agreement. Finance subject to status, full terms and conditions available on request. Other finance options available. All prices exclude VAT at 20%. Price, availability and specification may change without prior notice. Warranty subject to manufacturers terms and conditions of use. Errors and omissions excluded. Offers valid until 31st March 2017. Prices correct at time of going to press: December 2016.

Auto Transmission Fluid Exchange

NO HASSLE WARRANTY

BEST PRICE PROMISE

With the high proportion of automatic transmission vehicles on the road, it makes sense to keep this capability in-house. Making simple work of scheduled service interval fluid changes, an automatic transmission fluid exchanger also offers a clean 'first option' for fixing problems including 'sealed for life' boxes. A simple flush and refill can often cure the problem and is an easy option to sell before going to the expense of a full strip-out at a specialist.



LAUNCH CAT501S 590 00 1060

DEMO AVAILABLE

The CAT-501S offers a range of automatic functions to exchange transmission fluid with minimal fuss and involvement. May also be used in a manual operation. The CAT-501S is supplied with a full set of connectors.

- 5" LCD display
- Oil exchange and level adjustment
- Print out the procedure and more vehicle data
- Monitoring of oil temperature
- Monitoring of oil pressure
- Empty fluid tank without disassembly
- Choose between 68 pieces universal adapters kit and bespoke UK adapters kit
- Online database access included
- 2 year warranty

The majority of manufacturers recommend changing the ATF fluid on automatic gearboxes every 30,000 to 40,000 miles.

Any of these symptoms below can be made better by a 100% ATF fluid flush and refill

- Rough gear change during acceleration
- Slow or delayed gearshifts
- Difficult to move from Park to Drive/Reverse
- Noisy gear changes or loud transmission running noise
- An increase in transmission vibrations felt inside the cabin

An ATF flush and refill produces the following benefits

- Smoother gear change
- Reduced transmission noise
- Easier gear selection
- Reduced transmission vibrations
- Faster up-shift during acceleration

**PAYS FOR ITSELF
IN JUST 6 MONTHS
FROM JUST ONE SERVICE PER WEEK***

*Return on investment example is not a guarantee of earnings. Based on 1 service per week charged out at £ 250 +vat

	COSTS/REVENUE
Service to Garage Customer	£250.00
Cost of Flush	-£8.50
Cost of Fluid	-£90.00
Labour and overheads	-£25.00
Profit Per Service	£126.00



WEEKLY FROM ONLY **£14.09⁺**
ONLY **£2,795.00**



WERTHER AGA EVO 590 00 1080

- Removes dirt and metal particles through a flushing process
- Supervised fluid replacement process is facilitated by pressure gauges and visual controls
- Supplied with a set of the most common essential fittings – 19 pieces essential adapters
- Additional fittings for less common gearboxes available as an option
- Database CD available at additional cost
- Semi-automatic
- 1 year warranty



WEEKLY FROM ONLY **£11.57⁺**
ONLY **£2,295.00**

*Finance example typically based on a 5 year lease purchase agreement. Finance subject to status, full terms and conditions available on request. Other finance options available. All prices exclude VAT at 20%. Price, availability and specification may change without prior notice. Warranty subject to manufacturers terms and conditions of use. Errors and omissions excluded. Offers valid until 31st March 2017. Prices correct at time of going to press: December 2016.

0845 603 3636
OVER 200 BRANCHES NATIONWIDE

Engine Treatment and Diesel Testing

NO HASSLE WARRANTY

BEST PRICE PROMISE

CARBON ZAPP ES3 DIESEL AND PETROL ENGINE TREATMENT UNIT

590 01 0220

An engine deep-clean is an obvious 'first option' to resolving high emissions or poor performance issues. Engine cleaning can also be offered within a standard menu of additional services available during routine service visits.

- One machine treats both petrol and diesel engines
- Adaptability to all makes and models
- Comes complete with a supply of detergent
- De-carbonisation of combustion chamber
- Maximum restoration of engine performance
- Exhaust emissions reduction by up to 70%
- High pressure pump conditioning
- Decarbonised valves and piston ring release
- Improved idle speed stability
- Fading of engine knocking
- Adaptors available for de-carbonisation of Intake Manifold and DPF (sold separately)

PAYS FOR ITSELF IN JUST 35 TREATMENTS!

WEEKLY FROM ONLY **£12.90⁺**
ONLY **£2,559.00**

INTAKE MANIFOLD ADAPTOR
590 01 0230

ONLY **£348.00**

DPF ADAPTOR ONLY
590 01 0240

ONLY **£390.00**



BOSCH EPS118 DIESEL INJECTION TESTER

596 77 0010

The EPS118 is so easy to use, it represents an entry-level opportunity for common rail injector testing. With the proportion of diesel vehicles continuing to grow every year, this is a route to earning more profit!

- Keep the business in the workshop – don't outsource this lucrative revenue earner
- Easy to operate even without previous experience
- Fast identification of defective injectors
- Report printout makes it easier to convince customers
- Unbeatable price
- Requires Calibration Oil (522 77 3515)



PAYS FOR ITSELF FROM JUST 2 TESTS PER WEEK!

WEEKLY FROM ONLY **£30.72⁺**
ONLY **£6,095.00**

CARBON ZAPP DS1R

590 01 0210

Test Bench for one Common Rail Diesel Injector at a time. Delivers a quick Pass / Fail test – no more than what a workshop really needs to know.

- Gives a 'workshop level' diagnosis
- 8" touch screen
- Manual or Automatic modes



WEEKLY FROM ONLY **£22.65⁺**
ONLY **£4,495.00**

*Finance example typically based on a 5 year lease purchase agreement. Finance subject to status, full terms and conditions available on request. Other finance options available. All prices exclude VAT at 20%. Price, availability and specification may change without prior notice. Warranty subject to manufacturers terms and conditions of use. Errors and omissions excluded. Offers valid until 31st March 2017. Prices correct at time of going to press: December 2016.



Wheel Service – High Volume

NO HASSLE
WARRANTY

BEST PRICE
PROMISE

HOFMANN MEGAPLAN MEGAMOUNT EASY

583 77 0420

The Megamount Easy represents an alternative style of tyre changer, where manual effort is reduced to a minimum, and the emphasis is on larger rims fitted with low profile tyres.

An integral wheel lifter makes light work of the heaviest assemblies, and the centre post clamping with the simple and speedy 'Smart Lock' ensures there is no contact with the outer edge of the rim. The famous Hofmann Megaplan 'Evolution' leverless system is enhanced with the new 'Lever No Lever' design, which enables the operator to switch between leverless operation and traditional lever & demount head at the flick of a switch.

Unlike many other 'Next Generation' tyre changers on the market, the EASY was designed with one major focus; simplicity. In every element of the tyre fitting and removal process, the directive has been to ensure that operation remains simple, minimising the number of controls and functions – Easy by name, and Easy by nature.

- 10" to 30" Clamping Capability via Centre Post method with 'Smart Lock'
- Lever No Lever system enables dual leverless or traditional levered fitting as preferred
- Integral wheel lifter
- Dynamic bead breaking system via roller
- 'Next generation' tyre changer design



WEEKLY FROM ONLY **£29.21***
ONLY £5,795.00

HOFMANN MEGAPLAN MEGASPIN 420

584 77 0370

The most advanced technology the industry has seen in a wheel balancer. The combination of revolutionary new technology, incredible simplicity, and typical Hofmann Megaplan reliability makes this, in our opinion, the best value wheel balancer on the market today.

Boasting 'No Checkspin' technology and 6 o'clock weight positioning, the Megaspin 420 only requires the operator to select the weight position(s) and lower the hood – it's that simple! Two laser points guide the operator to the chosen weight position, and the rim locks into position at each inner and outer 6 o'clock placement position.

There is no possibility for error, no chance of the machine throwing up an extra 5 or 10gms, and absolutely No Checkspin Required!

- Worlds' first balancer with 'No Checkspin' technology
- Easier 6 o'clock weight position
- Super Automatic Data Input via sonar (touch-free)
- Laser Guided weight placement
- Handles rims up to 30" diameter
- The simplest, fastest wheel balancer ever produced



WEEKLY FROM ONLY **£16.10***
ONLY £3,195.00

*Finance example typically based on a 5 year lease purchase agreement. Finance subject to status, full terms and conditions available on request. Other finance options available. All prices exclude VAT at 20%. Price, availability and specification may change without prior notice. Warranty subject to manufacturers terms and conditions of use. Errors and omissions excluded. Offers valid until 31st March 2017. Prices correct at time of going to press: December 2016.

0845 603 3636
OVER 200 BRANCHES NATIONWIDE

Wheel Service – High Volume

NO HASSLE
WARRANTY

BEST PRICE
PROMISE

HOFMANN MEGAPLAN MEGAMOUNT 503XL EVO

583 01 0210

Super-Automatic Operation and built-in 'Leverless' device makes this machine incredible value for money. It boasts luxury features such as 'Stroke Limiter' for the bead breaker to adjust the amount of travel when breaking the bead on tyres fitted to shallow-welled BMW rims, and it provides a future-proof clamping range of 14" to 26".

A 'bespoke' design to incorporate value with 'upmarket' features, the 503 Evo's incredible price/performance ratio puts leverless technology within the reach of even the modest garage or tyre shop.

- Leverless Operation
- 10" to 28" Clamping (26" External)
- 15" Rim Width Capability
- Includes 'megafit 2XL' assist arm
- BMW Run-Flat 'Stroke Limiter' as standard
- Double acting bead breaker

Leverless Operation:

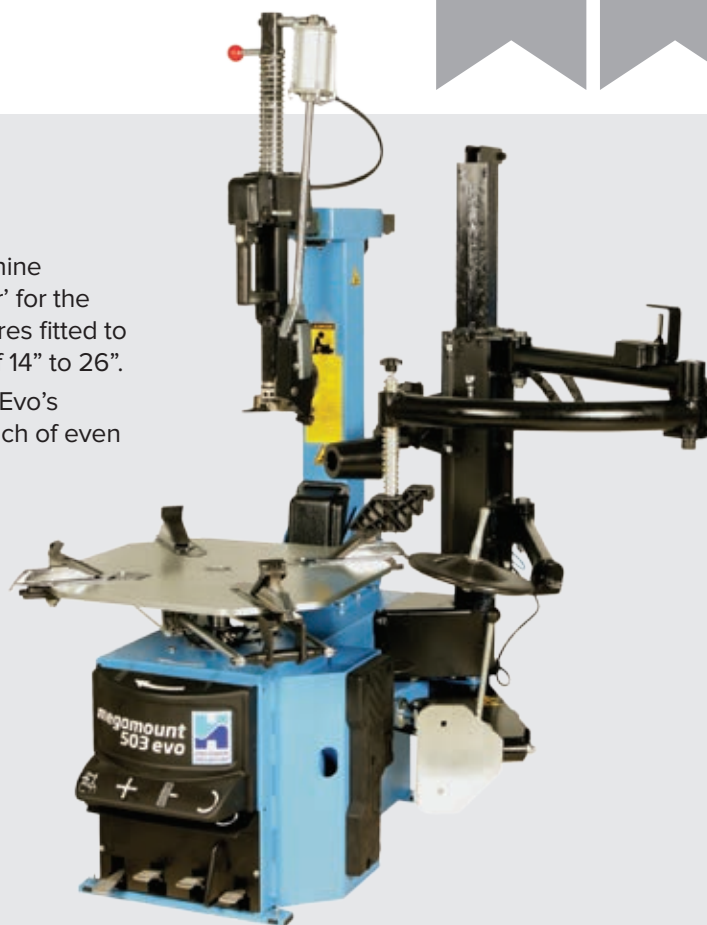

WEEKLY FROM ONLY **£26.69⁺**
ONLY **£5,295.00**

HOFMANN MEGAPLAN NG 90 NITROGEN GENERATOR

592 01 0070

There is no doubt about it, Nitrogen inflation is becoming more common as customers demand the service and anybody dealing with tyres will need to consider meeting the demand. In addition, certain new vehicles are coming out of the factory with nitrogen in the tyres as standard, setting the tone for nitrogen filling to become the 'norm' in the future.

THE BENEFITS

Longer Tyre Life – Improved wear due to maintaining the correct pressure for up to four times longer than filled with air
Increased Fuel Efficiency – Correct tyre pressures lessens the rolling resistance and maximises consumption
Increased Safety – Under-inflated tyres are the main reason for blow outs. Nitrogen filled tyres maintain pressures – that's why it's used in racing and aviation.
Nitrogen is a safe inert gas, non-flammable, non-corrosive.

Nitrogen inflation is a great add on opportunity for customers who buy performance tyres or for those concerned with economy. Charge or give it away as promotion to attract customers. More stable tyre pressures means less queuing at the petrol station!

The fully-automatic NG90 provides fast, simpler operation. Simply connect the hose up to the valve and set the required pressure, and then walk away and get on with another job. The NG90 will automatically purge the tyre and the switch to refill with nitrogen to the pressure selected.

- No need to buy gas – NG90 produces its own Nitrogen through a filtration process
- Fully portable – Can be used anywhere with a 13amp plug
- Automatic Operation – Connect and walk away, saves time
- Adjustable Display – Read measurements in Bar Or Psi

WEEKLY FROM ONLY **£5.01⁺**
ONLY **£995.00**



*Finance example typically based on a 5 year lease purchase agreement. Finance subject to status, full terms and conditions available on request. Other finance options available. All prices exclude VAT at 20%. Price, availability and specification may change without prior notice. Warranty subject to manufacturers terms and conditions of use. Errors and omissions excluded. Offers valid until 31st March 2017. Prices correct at time of going to press: December 2016.



Wheel Service – High Volume

NO HASSLE
WARRANTY

BEST PRICE
PROMISE

HOFMANN MEGAPLAN MEGAMOUNT 503XL

583 77 0410

Fully Automatic and boasting a 'top end' specification, the Megamount 503XL is capable in any environment. The patented, adjustable turntable enables alloy rims up to 26" in diameter to be clamped from the outside, and the tall column and wide bead breaker opening ensures suitability for extra-wide rims up to 15". A bead breaker 'stroke limiter' for shallow-welled BMW rims and quick-release, interchangeable demount head system, with standard/run-flat, plastic and 'raised spoke' heads, completes the luxury specification.

- 10" to 28" Clamping (26" external)
- 15" Rim Width Capability
- Quick-Release Demount Head System for Standard/RFT, Plastic and 'Raised Spoke'
- Includes 'Megafit 2XL' assist arm
- BMW/Run-Flat 'Stroke Limiter' as standard
- Double-acting bead breaker
- Fully-Automatic Operation



WEEKLY
FROM ONLY **£20.13⁺**
ONLY **£3,995.00**

**UPGRADE TO MEGAMOUNT 503 EVO
WITH LEVERLESS OPERATION
FOR ONLY £ 1,299 +VAT**



HOFMANN MEGAPLAN MEGASPIN 200V

583 05 0510

The Megaspin 200V has to offer one of the best price/performance ratios of any wheel balancer on today's market. Fully-automatic (3D) data input is achieved using the inner measuring/weight placement arm and Hofmann Megaplan's revolutionary IWA (Intelligent Width Assessment) software.

Values are displayed live on the full colour TFT display. The displayed graphics will guide the operator to the designated weight placement position, as well as delivering what is probably the simplest, fastest method of 'split weight' (hiding the weights behind the spokes) ever.

- 3D Fully-Automatic Data Input via IWA
- Colour TFT Display
- Can handle rims up to 30" diameter
- Simple, speedy operation
- 4 years PCB Warranty



WEEKLY
FROM ONLY **£12.57⁺**
ONLY **£2,495.00**



*Finance example typically based on a 5 year lease purchase agreement. Finance subject to status, full terms and conditions available on request. Other finance options available. All prices exclude VAT at 20%. Price, availability and specification may change without prior notice. Warranty subject to manufacturers terms and conditions of use. Errors and omissions excluded. Offers valid until 31st March 2017. Prices correct at time of going to press: December 2016.

0845 603 3636
OVER 200 BRANCHES NATIONWIDE

Wheel Service – Medium Volume



BOSCH TCE 4400 583 01 0120

Specially designed for medium volume workshops.
New 'G-frame' concept, new design of jaws and turntable.

- New "worldwide standard" positioning of the control pedal in order to avoid misuse or error by using other similar products
- Includes inflating system controlled by gun equipped with scale manometer bar/psi
- Bead breaker pad shape designed in order to avoid any scratch on the rim
- Lubricant bucket holder (adjustable for every bucket size and position)
- Helper arm has 2 independent pressing points



WEEKLY FROM ONLY **£17.11⁺**
ONLY **£3,395.00**

BOSCH WBE 4200 WHEEL BALANCER 584 04 0370

Semi-automatic wheel balancer offers garages and workshops a simple, high precision and easy-to-use value machine. Clear digital read-outs for passenger cars, light commercial vehicles and motorcycles, with a new ergonomic design allowing for better access to the inside of the wheel and an improved working position, creating more comfort for the user.

- Comes with 2 years warranty as standard with the option of additional service/calibration plans
- Manufactured in Europe
- Space-saving slim design
- Measuring time – just 8 seconds
- Automatic detection system to position weights
- Automatic locking of the arm in position
- Analog display



WEEKLY FROM ONLY **£10.31⁺**
ONLY **£2,045.00**

JOHN BEAN T5305 SINGLE SPEED TYRE CHANGER WITH ASSIST ARM AND B100 WHEEL BALANCER 583 01 0170

New package including tilt back tyre changer for all conventional tyres on the market, including helper arm and 10-20" clamping range and digital wheel balancer capable of measuring wheel offset and wheel diameter in one process (2 dimensions of semi-automatic parameter entry – 2D SAPE)

T5305 FEATURES

- Pneumatic lifting column – fast and safe wheel lifting
- Turntable has two cylinders for improved gripping of the rim
- Assist arm includes drop centre pressing tool and rim centre pushing tool – accuracy and ease of use as standard

B100 FEATURES

- Includes patented VPI system for high accuracy and repeatability
- Split weight mode – hide weights behind wheel spokes for more appealing cosmetic finish
- Tyre-matching mode – optimise tyre to rim so using fewer weights



WEEKLY FROM ONLY **£20.13⁺**
ONLY **£3,995.00**



*Some run-flat tyres may require additional adaptors

*Finance example typically based on a 5 year lease purchase agreement. Finance subject to status, full terms and conditions available on request. Other finance options available. All prices exclude VAT at 20%. Price, availability and specification may change without prior notice. Warranty subject to manufacturers terms and conditions of use. Errors and omissions excluded. Offers valid until 31st March 2017. Prices correct at time of going to press: December 2016.



Wheel Service – Low Volume

NO HASSLE WARRANTY **BEST PRICE PROMISE**

WERTHER TITANIUM COMPLETE TYRE PACKAGE 583 01 0030

- Fully automatic tyre changer plus wheel balancer
- Single phase supply
- Including assistant arm
- From 11" to 24" wheels



WEEKLY FROM ONLY **£12.07***
ONLY £2,395.00

HOFMANN MEGAPLAN ECOMOUNT 11XL CHANGER AND MEGASPIN 120 BALANCER 583 01 0190

Semi-automatic, side swing tyre changer with assist arm designed for anybody looking for an entry-level machine without compromising on reliability and long term support. The first 'handspin' balancer ever to include fully-automatic (3D) data input.

UPGRADE THE CHANGER TO ECOMOUNT 22PLUS FOR ONLY £ 300.00 +VAT!



WEEKLY FROM ONLY **£13.58***
ONLY £2,695.00

JOHN BEAN BOXER BB2200 TYRE CHANGER AND BB4100 WHEEL BALANCER 583 05 0290

Tilt Back Tyre Changer and Digital Wheel Balancer newly released to provide great value for money to garages wanting to expand into tyre and wheel servicing.



WEEKLY FROM ONLY **£14.84***
ONLY £2,945.00

PROWAY ELITE 220 TYRE CHANGER AND ELITE 110 WHEEL BALANCER 583 77 0930

- Reliable and efficient design.
- Extensively tested prior to delivery.
- Operator training included.
- The ideal entry-level option.



WEEKLY FROM ONLY **£13.33***
ONLY £2,645.00

*Finance example typically based on a 5 year lease purchase agreement. Finance subject to status, full terms and conditions available on request. Other finance options available. All prices exclude VAT at 20%. Price, availability and specification may change without prior notice. Warranty subject to manufacturers terms and conditions of use. Errors and omissions excluded. Offers valid until 31st March 2017. Prices correct at time of going to press: December 2016.

Mid-Rise Scissor Lifts

NO HASSLE
WARRANTY

BEST PRICE
PROMISE

JOHN BEAN SSL 33 ELECTRO-HYDRAULIC MID-RISE LIFT 581 05 0010

Portable lift designed to lift cars and light commercial vehicles.

- Small size and portability make this a great investment for any busy garage
- Single phase operation
- 1m lifting height
- Pneumatic safety lock
- Includes mobile kit



WEEKLY FROM ONLY **£13.08⁺**
ONLY £2,595.00

CRYPTON CML3000 581 77 0320

An efficient, fully versatile and flexible mobile solution that covers 90% of all activities in the workshop for vehicles up to 3t in weight.

- Lifts vehicles to a comfortable one metre for fast refits of wheels and tyres, inspecting brakes and suspension and underbody, paint and bodywork
- Stuck for space? Easily move the lift around your workshop with no problem to create additional working space for inside and even outside the workshop
- Anti-skid lifting platforms are galvanised and can be adjusted in length
- Simple, easy and quick set-up
- Includes mobile kit



WEEKLY FROM ONLY **£15.09⁺**
ONLY £2,995.00

LIFTMASTER SPRINTER 3T MID-RISE SCISSOR LIFT 581 77 0030

With one meter lifting height, the Sprinter covers 90% of all activities in the workshop. Thanks to the mobile kit (supplied as standard), the lift is easily moveable around the workshop.

By picking up the vehicle at the sillboards, the Sprinter safely picks up most vehicles (including SUV vehicles), up to 3 Tons. Super ductile polymer pads (supplied as standard) protect the car's underbody.

Ideal for Wheel and Tyre work, Chassis and Underbody work; Bodypanel and Smart repair; Valeting and Detailing

Capacity (kg)	3000
Lifting time approx. (sec.)	11
Lifting height (mm)	990
Drive over height (mm)	102
Runway length (mm)	1400-2010
Runway width (mm)	450
Motor (kW)	1,5
Power supply (V / Hz / A)	400 / 50 / 16

WEEKLY FROM ONLY **£14.09⁺**
ONLY £2,795.00



- Almost 1 metre lifting height
- Electro-Hydraulic operation
- Fully mobile
- Lifting platforms adjust from 1400-2010mm
- Includes mobile kit

*Finance example typically based on a 5 year lease purchase agreement. Finance subject to status, full terms and conditions available on request. Other finance options available. All prices exclude VAT at 20%. Price, availability and specification may change without prior notice. Warranty subject to manufacturers terms and conditions of use. Errors and omissions excluded. Offers valid until 31st March 2017. Prices correct at time of going to press: December 2016.



4 Post and Full-Height Scissor Lifts

NO HASSLE WARRANTY

BEST PRICE PROMISE

BRADBURY H8 SERIES SHORT PLATFORM SCISSOR LIFTS

Ideal for service bays, tyre shops, general repair, brake repairs, suspension and transmission replacement and body shops. Featuring a low profile platform ideal for lifting a large range of vehicles including low skirted sport cars.

Bradbury H8903/H8901E 3.2t extra low profile

Bradbury H8603/H8601E 3.6t Short Platform Recessed Scissor Lift

- Hydraulically synchronised platforms.
- Improves utilisation of workshop space.
- Full access to sides, front and rear of vehicle.
- Ideal for service bays, tyre shops and general repair.
- Complete with lifting blocks.
- Safety valves detects hydraulic failure.
- Overload mechanical safety device – Ratchet safety mechanism engages each time the lift stops throughout the lifting height of 1850mm.
- Control panel allows precise lifting.
- Reflector/light beam sensor ensures platform remains level during lift.

2 YEARS WARRANTY



Bradbury H8903E/H8901E

H8903E

Surface mounted, 3 Phase
581 77 0090

WEEKLY FROM ONLY **£18.37⁺**
ONLY **£3,645.00**

H8901E

Surface mounted, 1 Phase
581 77 0100

WEEKLY FROM ONLY **£18.37⁺**
ONLY **£3,645.00**



Bradbury H8603E/H8601E

H8603E

Recessed, 3 Phase
581 77 0070

WEEKLY FROM ONLY **£18.37⁺**
ONLY **£3,645.00**

H8601E

Recessed, 1 Phase
581 77 0080

WEEKLY FROM ONLY **£18.37⁺**
ONLY **£3,645.00**

BENDPAK 4 POST SERVICE LIFTS – ROBUST AND RELIABLE

- Longer approach ramps for low ground clearance vehicles
- Fully enclosed lifting cables, locks and sheaves minimising contaminant ingress and maintenance
- Single hydraulic cylinder mounted under platforms – less to go wrong
- Single phase or three phase
- 1 year warranty

JACKING BEAM INCLUDED



HD-9 4T 4 Post Service Lift
with 4166mm platforms
578 77 0050

WEEKLY FROM ONLY **£19.63⁺**
ONLY **£3,895.00**

HD9XW 4T 4 Post Service Lift
with 4775 mm platforms
578 77 0080

WEEKLY FROM ONLY **£21.14⁺**
ONLY **£4,195.00**



HDS14LSX 6.3T 4 Post alignment Lift
with 5054 mm platforms
578 77 0090

WEEKLY FROM ONLY **£34.65⁺**
ONLY **£6,875.00**

*Finance example typically based on a 5 year lease purchase agreement. Finance subject to status, full terms and conditions available on request. Other finance options available. All prices exclude VAT at 20%. Price, availability and specification may change without prior notice. Warranty subject to manufacturers terms and conditions of use. Errors and omissions excluded. Offers valid until 31st March 2017. Prices correct at time of going to press: December 2016.

2 Post Clearfloor Lifts

NO HASSLE WARRANTY

BEST PRICE PROMISE

LIFTMASTER LMS SERIES

European Mechanical 3t 2-post lift.

- Electro-Mechanical operation
- Integrated dual motors
- Available with a higher lifting capacity and a variety of arms – choose your ideal configuration
- 2 years warranty (rolling warranty available)

ASK ABOUT OUR EXTENDED WARRANTY AND CARE PLANS



LMS3000

Standard configuration 577 77 0010



WEEKLY FROM ONLY **£14.84⁺**
ONLY £2,945.00

LMS3000TRA

with 3-stage arms 577 77 0120



WEEKLY FROM ONLY **£15.85⁺**
ONLY £3,145.00

LMS3500

3.5t version 576 01 0060



WEEKLY FROM ONLY **£16.86⁺**
ONLY £3,345.00

LIFTMASTER LMH SERIES

- Single hydraulic master and slave cylinder design provides smooth and fast lifting
- The all-hydraulic system requires no electrical and pneumatic component
- Synchronising cables are not required as the hydraulic system ensures fast and safe synchronisation at any level
- The load is secured at any working height without mechanical ratchet
- Speed: 20 sec. up, 14 sec. down

- Quiet, powerful, oil submerged motor gives fast lifting and lowering times
- Low maintenance and almost wear-free cylinders
- Asymmetric arms for maximum door clearance
- Self-bleeding hydraulic system
- Low lifting height
- Available in single phase or three phase

LMHS3001

577 77 7310



WEEKLY FROM ONLY **£15.35⁺**
ONLY £3,045.00

LMHS3003

577 77 7290



WEEKLY FROM ONLY **£14.49⁺**
ONLY £2,875.00

LMH3000

577 77 0680



WEEKLY FROM ONLY **£17.36⁺**
ONLY £3,445.00

LMH3000TRA

577 77 0700



WEEKLY FROM ONLY **£18.62⁺**
ONLY £3,695.00



*Finance example typically based on a 5 year lease purchase agreement. Finance subject to status, full terms and conditions available on request. Other finance options available. All prices exclude VAT at 20%. Price, availability and specification may change without prior notice. Warranty subject to manufacturers terms and conditions of use. Errors and omissions excluded. Offers valid until 31st March 2017. Prices correct at time of going to press: December 2016.

2 Post Baseplate Lifts

NO HASSLE WARRANTY

BEST PRICE PROMISE

L4000 M/E 2 POST 4 TON HYDRAULIC LIFT

This value lift has a lot to offer. Symmetric arms offer wide flexibility of chassis as well as being able to accommodate vehicles driving on or reversing on. Electro-magnetic safety locks conveniently release at the push of a button. (A manual lock release version of this lift is also available)

- Hydraulic hoses and balance cables are all fully concealed, providing a clean appearance.
- The double hydraulic cylinders and high strength chain drive provide smooth lifting and lowering.
- The two sets of arms always travel synchronously thanks to high strength balancing cables.
- An emergency lowering valve can be manually operated to lower the lift safely in the event of a power failure.
- Meanwhile, a flow-control valve prevents the possibility of a rapid uncontrolled descent
- Door rubbers on the posts protect the car doors from direct contact, and sill protector rubbers on the upper arms perform the same function protecting the undersides of longer chassis vehicles



- Minimum pad height 110mm
- Drive-thru width 2486mm
- Maximum Lifting Height 1950mm
- Lifting time 40-50sec
- Lowering time 20-40sec



MANUAL LOCKS 1 PHASE

577 01 0060

WEEKLY FROM ONLY **£10.31⁺**
ONLY £2,045.00

ELECTRONIC LOCKS 1 PHASE

577 01 0070

WEEKLY FROM ONLY **£11.82⁺**
ONLY £2,345.00

ELECTRONIC LOCKS 3 PHASE

577 01 0080

WEEKLY FROM ONLY **£11.82⁺**
ONLY £2,345.00

BENDPAK XPR SERIES

NEW UPDATED MODELS

Low-profile, dropped-end frame c/w NEW screw contact pads

Squeeze under even the lowest compact and sport vehicles. The new adjustable screw pads ensure that the vehicle is lifted safely at all times

Triple-telescoping front arms and two-stage rear arms

Increases overall arm positioning for lifting a variety of different wheel base vehicles. Overall arm sweep and minimum arm reach are also extended to precisely lift vehicles that have unibody construction, OEM recommended pick-up points and wide and / or narrow wheelbase configurations.

Maintenance-free load bearings

Rather than using roller bearings that need to be constantly lubricated, every XPR-Series Lift carriage uses high-tech UHMW (ultra-high molecular weight polyethylene) load bearings that never need lubrication and are designed to last the entire life of the lift.



NOW SUPPLIED WITH ADJUSTABLE HEIGHT SCREWPADS AS STANDARD

XPR9TS 577 77 0020



WEEKLY FROM ONLY **£16.71⁺**
ONLY £3,315.00

XPR10TS 577 77 0240



WEEKLY FROM ONLY **£16.86⁺**
ONLY £3,345.00

XPR12FDL 577 77 0030



WEEKLY FROM ONLY **£24.67⁺**
ONLY £4,895.00

*Finance example typically based on a 5 year lease purchase agreement. Finance subject to status, full terms and conditions available on request. Other finance options available. All prices exclude VAT at 20%. Price, availability and specification may change without prior notice. Warranty subject to manufacturers terms and conditions of use. Errors and omissions excluded. Offers valid until 31st March 2017. Prices correct at time of going to press: December 2016.

2 Post H-Frame Lifts



BRADBURY HYDRAULIC 2 POST LIFTS

- Baseless option – ideal for transmission jacks
- 3 stage arms and large, adjustable dual screw lifting pads
- Electro-mechanical locking device
- Easy access for cable adjustment



BRADBURY H2401/3

4t standard length posts



WEEKLY FROM ONLY **£16.86⁺**
ONLY **£3,345.00**

BRADBURY H2601/3

6t standard length posts



WEEKLY FROM ONLY **£24.67⁺**
ONLY **£4,885.00**

BRADBURY H2401/3

4t extra height posts



WEEKLY FROM ONLY **£17.87⁺**
ONLY **£3,545.00**

BRADBURY H2601/3

6t extra height posts



WEEKLY FROM ONLY **£26.18⁺**
ONLY **£5,195.00**

TECALEMIT SF/9207 – SENTINEL 4 TON HYDRAULIC 2 POST LIFT WITH BASE FRAME AND 3 STAGE ARMS

The SF 9207 is mounted on a heavy duty steel base frame which ensures a stable lifting platform and the minimum lifting pad height of only 100mm ensures that even vehicles with low ground clearance can be accommodated on the lift.

The lift has 3 stage arms enabling the lift to be used on a wider range of vehicles.

- Electro-hydraulic operation
- Asymmetric lifting arms 3 stages for lifting a wide range of vehicles
- Rapid lifting time
- Structural base frame
- Electronically controlled safety latches



INCLUDES FREE HIGH LIFT PADS



577 77 0370



WEEKLY FROM ONLY **£16.35⁺**
ONLY **£3,245.00**

577 77 0360



WEEKLY FROM ONLY **£15.09⁺**
ONLY **£2,995.00**

TECALEMIT SF/8909/H – AZUR 3 TON 2 POST LIFT WITH BASE FRAME 576 77 0230

- Suitable for lifting most passenger cars and car derived vans
- Automatic arm locking
- 5 Year warranty on self-lubricating Nylatron operating and safety nuts
- Low minimum lifting pad height of just 90mm
- Foot/toe protection device using an audible buzzer
- Heavy duty base-frame



WEEKLY FROM ONLY **£10.71⁺**
ONLY **£2,125.00**

*Finance example typically based on a 5 year lease purchase agreement. Finance subject to status, full terms and conditions available on request. Other finance options available. All prices exclude VAT at 20%. Price, availability and specification may change without prior notice. Warranty subject to manufacturers terms and conditions of use. Errors and omissions excluded. Offers valid until 31st March 2017. Prices correct at time of going to press: December 2016.



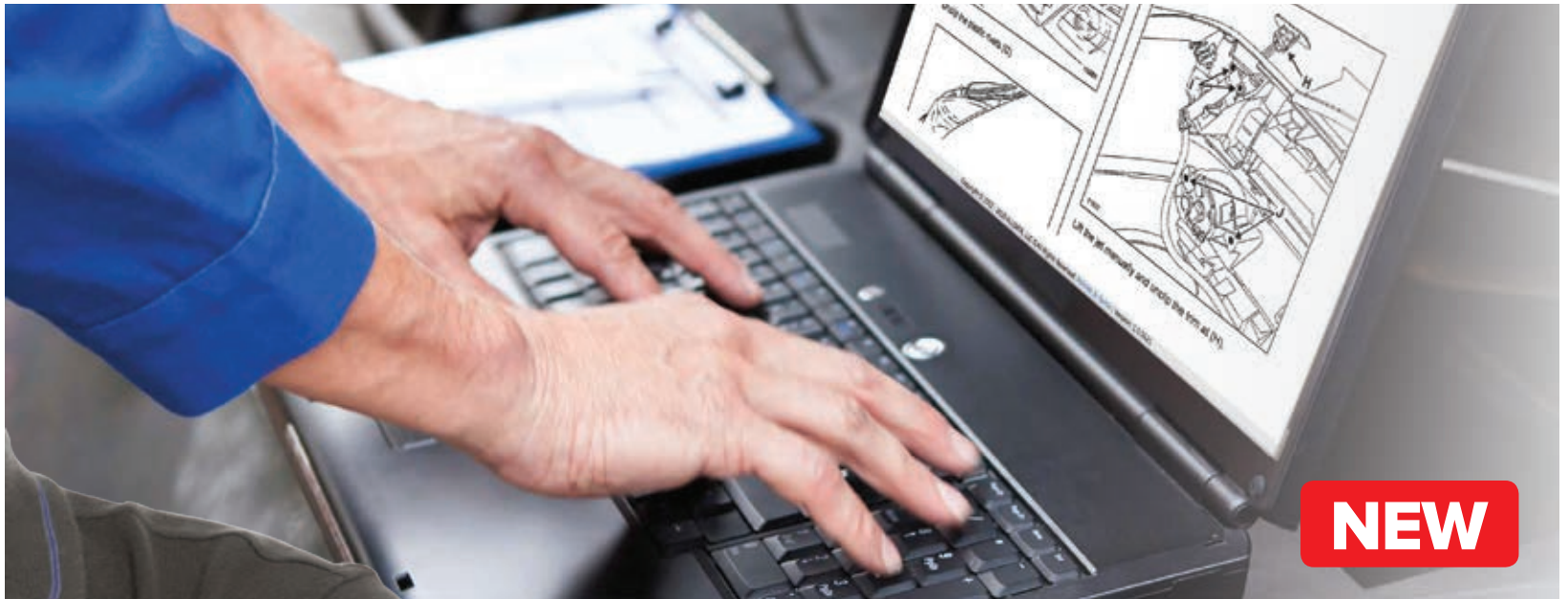

ALLDATA REPAIR®

You pride yourself on doing the job, so start with the right information. ALLDATA doesn't alter the OEM data, so you get exactly what you need from each manufacturer – all in one easy-to-use portal.

ALLDATA Repair® is a comprehensive online OEM repair information solution including 22 vehicle brands and more than 24 million articles of unaltered and unedited factory- correct data.

Automotive repair shops using ALLDATA improve repair quality and accuracy, save time and money and meet manufacturer standards, improving customer satisfaction and business profitability.

ALLDATA Repair® is the industry standard for original licensed OEM repair information. ALLDATA does not edit or redraw, so you can repair exactly to manufacturer standards. Using ALLDATA Repair®, you have instant access to diagnostic trouble codes on

every vehicle and every type of fix for all the leading car manufacturers so you can quickly diagnose and complete quality, heavy diagnostic work on today's complex vehicle technology. ALLDATA Repair® is very simple to use, it has a single- source online portal available which is available 24/7.

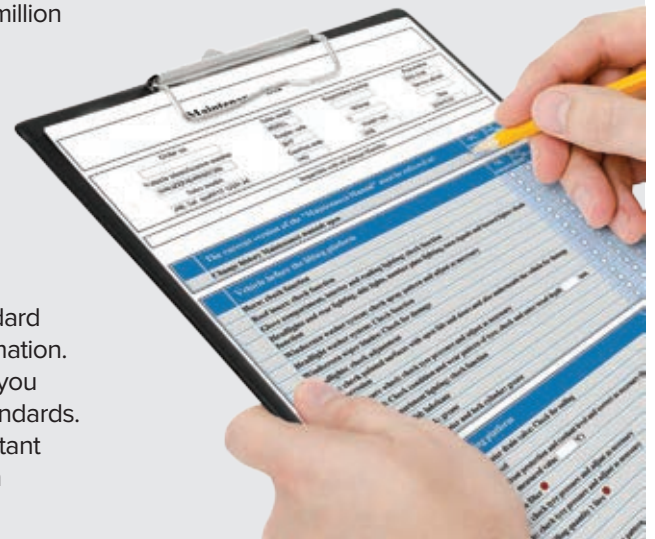

- Electrical wiring diagrams
- Factory mechanical repair procedures
- Factory chassis repair instructions
- Trouble codes and diagnostic test charts
- Technical service bulletins (TSBs)
- Filling quantities
- Maintenance interval and service schedules
- Tightening torques

ALLDATA Repair® currently covers the following vehicle brands: AUDI, Alfa Romeo, BMW, Citroën, Dacia, Fiat, FORD, Lancia, MAZDA, MERCEDES, MINI, Nissan, OPEL, Peugeot, Renault, SEAT, Škoda, Smart, Vauxhall, VW and more.

*Finance example typically based on a 5 year lease purchase agreement. Finance subject to status, full terms and conditions available on request. Other finance options available. All prices exclude VAT at 20%. Price, availability and specification may change without prior notice. Warranty subject to manufacturers terms and conditions of use. Errors and omissions excluded. Offers valid until 31st March 2017. Prices correct at time of going to press: December 2016.

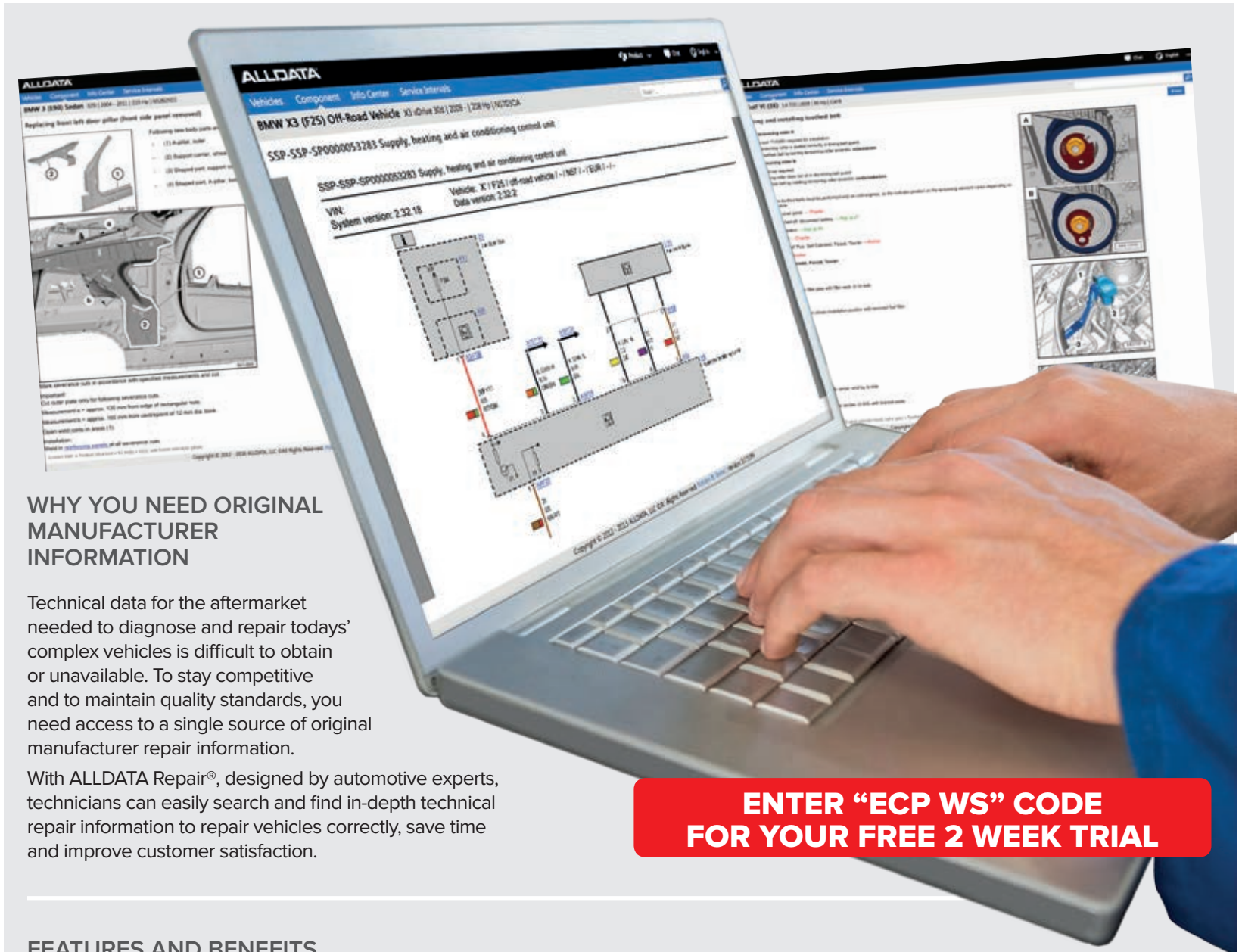

**ENTER "ECP WS" CODE
FOR YOUR FREE 2 WEEK TRIAL**

WHY YOU NEED ORIGINAL MANUFACTURER INFORMATION

Technical data for the aftermarket needed to diagnose and repair today's complex vehicles is difficult to obtain or unavailable. To stay competitive and to maintain quality standards, you need access to a single source of original manufacturer repair information.

With ALLDATA Repair®, designed by automotive experts, technicians can easily search and find in-depth technical repair information to repair vehicles correctly, save time and improve customer satisfaction.

FEATURES AND BENEFITS

- OEM repair information direct from the manufacturer including 22 brands and 24 million articles of unedited and original repair articles in a comprehensive online portal. Available in five languages, you have access to an easy-to-use navigation structure and search to save you time, increase efficiency, and improve overall profitability.
- Access to the industry's largest source of OEM information online 24/7.
- With original manufacturer maintenance, diagnostic and repair information, you save time and money, and can repair vehicles to quality standards, and drive repeat business.
- Access to the most current manufacturer information so you can repair the newest vehicles on the road and ensure every repair is profitable.
- Common navigation across all brands and advanced search capability make it easy to find the information you need quickly and efficiently.

**1 USER
12 MONTH SUBSCRIPTION
256 77 1770**

ONLY PER MONTH £69.00

**3 USER
12 MONTH SUBSCRIPTION
256 77 1760**

ONLY PER MONTH £83.00

**ADDITIONAL USER
OVER 3 LICENSES PER MONTH
256 77 1780**

ONLY PER MONTH £15.00

*Finance example typically based on a 5 year lease purchase agreement. Finance subject to status, full terms and conditions available on request. Other finance options available. All prices exclude VAT at 20%. Price, availability and specification may change without prior notice. Warranty subject to manufacturers terms and conditions of use. Errors and omissions excluded. Offers valid until 31st March 2017. Prices correct at time of going to press: December 2016.

AUTODATA

Autodata is the ultimate online tool to provide quick and easy access to technical information to efficiently carry out complex diagnostics and repair procedures, as well as day-to-day servicing and maintenance operations. Genuine manufacturer data, delivered in an easy-to-use consistent format covering 80 vehicle manufacturers and 29,000 models worldwide.

- Full service and maintenance procedures
- Data embedded directly into service schedules
- Interactive coloured wiring diagrams
- Fast and easy diagnostics and troubleshooting
- Interactive component location
- Comprehensive technical data and specifications

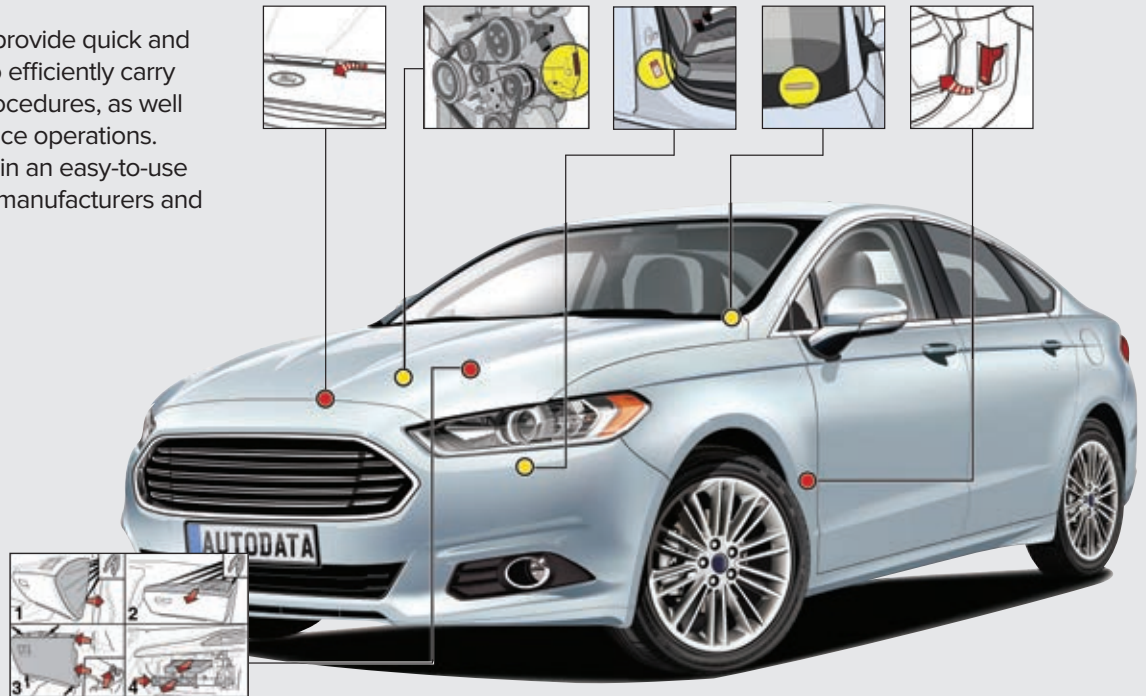

DESCRIPTION	PART NUMBER	PRICE
Autodata, Service & Maintenance Subscription Package 1 User – monthly subscription	256 77 1451	£43.75
Autodata, Service & Maintenance Subscription Package 2 Users – monthly subscription	256 77 1491	£50.33
Autodata, Service & Maintenance Subscription Package 5 Users – monthly subscription	256 77 1511	£61.25
Autodata, Diagnostic & Repair Subscription Package 1 User – monthly subscription	256 77 1371	£73.00
Autodata, Diagnostic & Repair Subscription Package 2 Users – monthly subscription	256 77 1521	£84.00
Autodata, Diagnostic & Repair Subscription Package 5 Users – monthly subscription	256 77 1531	£102.00

HELLA GUTMANN HGS DATA

356 77 6470

The complete vehicle technical database, accessible through any internet-enabled PC, with information and repair solutions for over 38,000 vehicles.

With HGS Data you can access all the technical data you require for virtually any service or repair job, all at the touch of a button.

Technical specifications for over 38,000 vehicle models, as well as maintenance plans, engine control, ABS, airbag and thermal management data, updated repair aids and wiring diagrams are all covered.

- 2 logins per subscription from any online device
- Technical data for over 38,000 vehicles
- Circuit diagrams
- Air bag, thermal management and engine control data

ONLY **£499.00**



*Finance example typically based on a 5 year lease purchase agreement. Finance subject to status, full terms and conditions available on request. Other finance options available. All prices exclude VAT at 20%. Price, availability and specification may change without prior notice. Warranty subject to manufacturers terms and conditions of use. Errors and omissions excluded. Offers valid until 31st March 2017. Prices correct at time of going to press: December 2016.

HELLA DIAGNOSTICS AT A GLANCE

Communication

- Clear and concise Vehicle identification through number plate recognition, manual input or VIN search.

Interface

- Wireless and compact VCI, also Pass-Thru function using relevant OE Platforms and software, total flexibility.

Data Retrieval

- Up to 12 selectable channels of live data with graphing option, waveform save function for road test facility, freeze data function, this is also printable.

Data Interpretation

- Clear and detailed description of fault codes, including component function and possible causes of fault.
- Real-Time Repair Concept allowing technical support direct to the device and data to be directly sent to our technical team. Onboard technical data including ECU pin out data, wiring diagrams, component location and vehicle technical data, to assist with fast efficient fault diagnosis.

Coding and Special Functions

- Extensive activations covering most vehicle systems, enables quick identification of a failed component. In depth coverage of Basic settings and Adaptions, a must when components are replaced.

Job Recording

- Car history function; stores the last 500 vehicles tested and can be recalled simply by date or vehicle registration, full A4 printable vehicle report, with date and time stamp, business name and registration number for a professional customer report.

HELLA GUTMANN MEGA MACS PC

355 77 5520 + 356 77 6750

Turns any Windows PC into a powerful diagnostic device with the same capabilities as the popular mega macs 42 SE. In conjunction with your Windows netbook, PC or tablet it's a flexible, highly portable and user-friendly all-round diagnostic solution for professional workshops, packed with features including Pass Thru® technology and complete with detailed ECU and system data for over 38,000 vehicle models.

- Suitable for your Windows netbook, PC or Tablet
- Comprehensive in-depth vehicle coverage
- Equipped with PassThru® technology



WEEKLY FROM ONLY **£8.44⁺**
ONLY **£1,675.00**

HELLA GUTMANN MEGA MACS 66

355 77 0000

Setting new standards in the field of diagnostics, the Mega Macs 66 includes several specialist features for faster, more accurate fault-finding and repair.

Centred around a large, full colour touch screen with an intuitive user interface, the Mega Macs 66 places interactive circuit diagrams, recommended procedures and error solutions directly on the screen

- Diagnostics of all components, with instructions
- Interactive coloured circuit diagrams with depiction of actual values and parameters in real-time.
- Vehicle-specific repair assistance, based on fault codes in real-time.
- Sets new standards in speed and accuracy of diagnosis

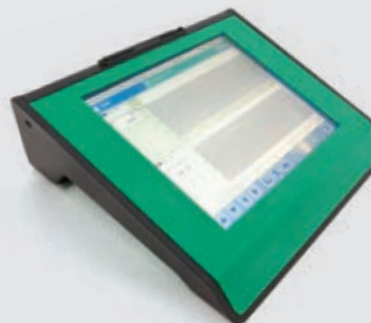

WEEKLY FROM ONLY **£23.94⁺**
ONLY **£4,750.00**

HELLA GUTMANN MEGA MACS 56

355 77 4720

The stakes have just been raised with the launch of the new Mega Macs 56 – an affordable, mid-range diagnostic tool with features normally found only on much pricier models.

- 800mhz processor – finds faults fast.
- 10.4" high-resolution full colour touchscreen enables on-screen information to be easily read in low light conditions.
- Wi-Fi and Bluetooth connectivity enable wireless printing. Downloads technical data quickly and easily even whilst in use.
- PassThru® ready
- HGS Technical Data technical data included
- Optional extra – measurements package comprising 2 channel oscilloscope and multimeter



ASK FOR A DEMO

WEEKLY FROM ONLY **£17.61⁺**
ONLY **£3,495.00**

*Finance example typically based on a 5 year lease purchase agreement. Finance subject to status, full terms and conditions available on request. Other finance options available. All prices exclude VAT at 20%. Price, availability and specification may change without prior notice. Warranty subject to manufacturers terms and conditions of use. Errors and omissions excluded. Offers valid until 31st March 2017. Prices correct at time of going to press: December 2016.

LAUNCH DIAGNOSTICS AT A GLANCE

Communication

- Multi manufacturer American, Asian & European 12v passenger car & light commercial coverage
- OBDII diagnosis and O.E level manufacturer specific vehicle coverage
- Comes complete with full cables & connectors set; for pre-2000, JOBD & OBD1 vehicles
- Up to 10m wireless Bluetooth connection with handheld tablet & vehicle

Interface

User friendly Android operating system platform, as found on majority of phones & tablets. If you can use a smartphone, you will have no trouble finding your way around a Launch interface.

Data Retrieval

- Lightning quick loading up time and fast vehicle diagnosis speed
- VIN recognition and Auto-ID on majority of vehicle modules & systems; minimises the risk of misidentifying the vehicle.
- Sensor simulator replicates vehicle sensors to test component to ECU wiring

- View Engine, ABS, SRS, Transmission and many more vehicle module data in list or graph form.
- Graph live data with vehicle running or stationary, using single or multiple graphs per page & overlap combination function.

Data Interpretation

- Built in comparison data for some vehicle manufacturers, updated frequently
- Multimeter & 4 Channel Oscilloscope (separate purchase) to further interrogate electrical systems
- Sensor simulation technology (separate purchase) to replicate electrical waveforms and to reduce unnecessary component replacement.
- Built-in fault codes 'help database', with explanations of possible causes & solutions
- Built-in capability using internet browser to access any technical data website

Coding and Special Functions

- Bi-directional component testing supported across all manufacturers for majority of vehicle systems such as; Engine, ABS, Automatic transmission,

SRS, Instrument panel, Body computer, Air suspension and many more.

- O.E.M component activation options such as retrofit coding, daytime running lights, seatbelt reminders, key fob & alarm customisations, convenience locking/unlocking, and season change settings plus access to many more vehicle configurations.

Job Recording

- Record live data from any vehicle system for up to 20 minutes per clip
- Save & share vehicle health reports in PDF format which can be printed or emailed wirelessly
- Playback, pause & view recorded data in graph or list form
- Remote vehicle diagnosis data recording, playback & vehicle reports
- Easy to take screenshots & share wirelessly by email or print, saved in jpeg format
- Company letter headed vehicle reports with option to add your own logo & shop details.
- Print via wireless printer (separate printer purchase required).

LAUNCH X431 EUROPAD 2 V2 (2016) EUROPAD 2

355 77 4640

- Durable handheld tablet in protective silicone case. Easy to read & operate multi-touch capacitive 10" LCD screen
- Has IP65 protection against solid objects; totally protected against dust & liquids
- Operates 4 Channel Oscilloscope, Multi meter & Endoscope camera as accessories (accessories must be purchased separately)
- Capable of 24v Heavy goods vehicle diagnosis – optional HD Truck module required

WEEKLY FROM ONLY **£12.07***
ONLY **£2,395.00**



*Finance example typically based on a 5 year lease purchase agreement. Finance subject to status, full terms and conditions available on request. Other finance options available. All prices exclude VAT at 20%. Price, availability and specification may change without prior notice. Warranty subject to manufacturers terms and conditions of use. Errors and omissions excluded. Offers valid until 31st March 2017. Prices correct at time of going to press: December 2016.

0845 603 3636
OVER 200 BRANCHES NATIONWIDE

LAUNCH X431 PRO AND PRO3

Based on the Android 5 operating system, the X431 Pro3S is the latest diagnostic tool from Launch.

With remote diagnostic features and a built-in social network, this tool encompasses the best in Launch technology and tablet computer usability.

Incorporating the best in already existing Launch diagnostic tools, the Pro3S can read and clear DTCs, read a car's data stream, perform actuation tests and much more, at lightning fast speeds.

Pro3S can perform diagnostics effectively on cars manufactured in Europe, America and Asia, and is compatible with all of their individual software; making the Pro3S one of the most reliable and all-encompassing diagnostic tools available on the market today.

Operates both wireless and bluetooth connectivity.

A built-in social network service enables users to connect to a community for help with diagnosis. Users also have access to a car database and repair tips, allowing for faster and more efficient performance.

- Full system diagnosis
- Data stream storage and re-display
- Service light resets
- Coding, reset and programming functions
- Diesel particulate filters regen/replacement
- Online technical support and advice
- Electronic parking brake reset
- Key/immobiliser coding
- VIN recognition, auto search
- Live data recording & multiple graphing
- Special functions for specific manufacturers
- Capable of 24v Heavy goods vehicle diagnosis – optional HD Truck module required

LAUNCH X431 PRO3S V2 (2016)

355 77 5150

Durable handheld tablet in protective silicone case.

Easy to read & operate multi-touch capacitive LCD 10" screen.



WEEKLY FROM ONLY **£8.54⁺**
ONLY **£1,695.00**

LAUNCH X431 PRO V2 (2016)

355 77 4860

Durable handheld tablets in protective silicone case.

Easy to read & operate multi-touch capacitive LCD 7" screen.



WEEKLY FROM ONLY **£6.02⁺**
ONLY **£1,195.00**

J-BOX 2 PASS THRU DEVICE

355 77 1450

J-Box 2, a thoroughly capable Pass Thru device that can be used for repairs and general maintenance on the majority of vehicle marques.

Easy to install on your PC, this device will help reprogramme control modules in-house, ensuring you can keep custom in your garage without needing to send them away to a dealership.

- support for over 36 OEM's
- how to videos included



WEEKLY FROM ONLY **£6.43⁺**
ONLY **£1,275.00**

HD TRUCK MODULE

355 77 5120

This Android powered heavy-duty truck module communicates wirelessly with the Pro 3 or Europad 2 host terminal to achieve fault diagnosis for various truck models. Provides a credible entry to truck diagnostics at a fraction of the cost of more specialist kits.

Coverage includes:

Man, Scania, Benz, Iveco, Daf, Hyundai, Volvo, Renault, Mitsubishi

- Includes full cable kit
- Works with Europad 2 only



WEEKLY FROM ONLY **£5.01⁺**
ONLY **£995.00**

*Finance example typically based on a 5 year lease purchase agreement. Finance subject to status, full terms and conditions available on request. Other finance options available. All prices exclude VAT at 20%. Price, availability and specification may change without prior notice. Warranty subject to manufacturers terms and conditions of use. Errors and omissions excluded. Offers valid until 31st March 2017. Prices correct at time of going to press: December 2016.

ESI[TRONIC] 2.0

ESI[tronic] 2.0 software is used in conjunction with the KTS range of diagnostic tools for vehicle fault diagnosis and service function procedures. The range of features available through the software is truly vast.

THE MAIN ESI PACKAGE ARE:

SD DIAGNOSTICS

Enables users to:

- Read Fault codes
- Erase Fault codes
- Collect Actual Data Values
- Actuate Components
- Carry out Function Tests
- Carry out service functions such as service lights, dpf, handbrakes, batteries and windscreens
- Carry out some coding

SIS TROUBLESHOOTING

Identifying a fault code is just the tip of the iceberg in a vehicle repair process. Troubleshooting is the solution to guide you to the root cause of the problem. It can guide the user from the fault code, real time data or symptoms through a number of tests to the root cause of the problem. It integrates the multimeter and scope (fitted to the KTS) to the guided diagnostics. SIS gives the user all of this in addition to the base SD package.

MP MASTER PACK

Troubleshooting takes users to the root cause, but users will need:

- Wiring diagrams for body electrics
- Technical bulletins
- Installation information
- Mechanical and service information
- Torque settings
- Locations and pin information on components

BOSCH DIAGNOSTICS AT A GLANCE

Communication

ESI[tronic] 2.0 information system can identify virtually any vehicle model and provide comprehensive data for workshops

- Capable of full multiplexing for all OEMs
- Diagnostics over internet protocol (DoIP)
- PassThru capability for all OEMs
- Parallel channel communication

Data Retrieval & Interpretation

Easy visual interpretation of results (green for right, red for wrong)

- Live comparative data with recordable graphical data for easy reference
- Fault code interpretation table
- ESI contains a vast library of OEM values
- Fully guided diagnostics connected to Bosch ESI[tronic] 2.0 data system giving wiring diagrams, component locations, component test plans, body circuit diagrams, common fixes, technical service bulletins etc.

Coding and Special Functions

Component actuation is available on most OEMs' ECMs where applicable

- Service functions such as component adding and actuation such as DPF resets, injector coding, calliper wind-back, SAS calibration are all available

Job Recording

- All usage sessions can be recorded
- Recording of live data
- Results can be printed
- Customer database can be created
- Customisation of data with garage details.

ROUGHLY CALCULATE YOUR KTS + ESI PACKAGE PRICE

HARDWARE

KTS560	£1,800
Upgraded to KTS590	add £300
DCU220 Tablet	add £2,400

SOFTWARE

ESI Standard Subscription annual subscription	£896
Master subscription	add £209
3 year Standard subscription (saves £ 443 over the period)	add £1,349
3 year Master subscription (saves £ 553 over the period)	add £1,689

*Finance example typically based on a 5 year lease purchase agreement. Finance subject to status, full terms and conditions available on request. Other finance options available. All prices exclude VAT at 20%. Price, availability and specification may change without prior notice. Warranty subject to manufacturers terms and conditions of use. Errors and omissions excluded. Offers valid until 31st March 2017. Prices correct at time of going to press: December 2016.

KTS560, KTS590

The new KTS stands alongside the new generation of OEM diagnostic tools capable of using parallel channels or diagnostics over the Internet to carry out diagnosis and software uploading. Offering much faster and efficient upload times, OEM's are increasingly using this type of communication. This will eventually become an industry standard.

Running the powerful Bosch ESI software in its own right, the new KTS is also capable of not only Pass Thru to an OEM software interface, but operating OEM software running from a separate laptop or pc. With verifications already in place with leading OEMs, the new KTS is a single hardware answer for operating one or more OEM software.

The new Bosch KTS560 and KTS590 have been proven to work on: Jaguar Land Rover, VAG, Vauxhall, Volvo & many others

- Works with any Windows-based PC that has a licensed version of the Bosch diagnostics software ESI[tronic]2.0 installed. Performs Pass Thru by working with OEM software*
- Operates OEM software with many approvals already in place
- Supports all of today's relevant diagnostic protocols including Diagnostics over Internet Protocol (DoIP) – and that means it's capable of all the latest OEM procedures

- USB2.0 and Bluetooth® connections means you can either stay tethered or not – your choice.
- Rugged design with high resistance to dust and water

NEW



*minimum spec. Windows7 and above

KTS560

355 77 9240

WEEKLY FROM ONLY **£9.05⁺**
ONLY **£1,795.00**

KTS590

with built-in Oscilloscope

355 77 9220

WEEKLY FROM ONLY **£11.06⁺**
ONLY **£2,195.00**

DCU 220

355 77 4690

DCU 220 (Diagnostic Control Unit) combines the features of a notebook with those of a tablet PC for flexible and comfortable working, especially under workshop conditions. When used as a tablet PC, the touchscreen is fast and easy, when a keyboard

is needed, the DCU 220 lends itself to being used as a notebook for any kind of usual computer work, such as the quick and easy entry of customer data. DCU 220 controls Bosch test and diagnostic systems, e.g. FSA 500 or the modules from the KTS series.

COMBINED TABLET / LAPTOP DIAGNOSTIC CENTRE:

CAREFULLY THOUGHT OUT DETAILS MAKE OPERATION EASIER

Easily switched from tablet to notebook mode – continue to work as you change

- Sturdy housing with 11.6" touchscreen monitor – view more data in one go
- Integrated camera: Document and use to show customers or order parts photographed

MOBILE WORK OVER EXTENDED PERIODS

- Inclusion of two identical lithium-ion batteries
- If required, batteries can be replaced without interruption (hot swap function)

MODULAR CONCEPT WITH THE DIAGNOSTIC CONTROL UNIT

For qualified diagnostics, professional repair and maintenance, Bosch offers the following modular system components: the DCU 220 convertible PC and the KTS 560, the KTS590 and the FSA 500. These can be freely combined to form a suitable solution for every workshop. Ask for more information.

WEEKLY FROM ONLY **£12.07⁺**
ONLY **£2,395.00**



*Finance example typically based on a 5 year lease purchase agreement. Finance subject to status, full terms and conditions available on request. Other finance options available. All prices exclude VAT at 20%. Price, availability and specification may change without prior notice. Warranty subject to manufacturers terms and conditions of use. Errors and omissions excluded. Offers valid until 31st March 2017. Prices correct at time of going to press: December 2016.

VDO and G-Scan 2 Diagnostics

NO HASSLE WARRANTY

BEST PRICE PROMISE

PICO MASTER KIT EVERYTHING FOR THE AUTOMOTIVE DIAGNOSTIC EXPERT

PicoScope's most comprehensive test kit is designed to be a complete solution for the professional diagnostic expert. It includes everything in the advanced kit along with a CAN breakout box and a full set of both multi and professional breakout leads. Pico's award winning WPS500X pressure transducer is also included, opening the door to pressure signal evaluation.

- Eliminate guesswork and test individual components before they are replaced. Stop playing "parts darts" where more and more parts are replaced until the fault goes away.
- Find intermittent wiring and connector faults.
- Solve issues when a vehicle has a problem but no code has been set or when multiple / misleading codes have been set
- Solve charging and starting problems.
- Solve problems with actuators such as motors and injectors that are not monitored by the ECU.
- Identify mechanical problems such as compression and slipped / incorrectly fitted timing belts



NEW

EURO ACADEMY PICO TRAINING COMING SOON

With the Pico Master kit you can run all of Pico's over 150 guided tests making it easier to diagnose electrical, mechanical, intermittent, performance and engine problems like never before.

PICO MASTER KIT
in plastic Carrycase PQ039
355779590

WEEKLY FROM ONLY **£20.13⁺**
ONLY **£3,995.00**

PICO MASTER KIT
In Foam Trays PQ040 (Pictured)
355779580

WEEKLY FROM ONLY **£20.13⁺**
ONLY **£3,995.00**

G-SCAN 2 DIAGNOSTICS AT A GLANCE

Communication

The G-Scan2 is the market-leading diagnostic tool for Asian cars, vans and trucks, being the ONLY current diagnostic tool with 100% genuine OEM developed software for Hyundai and Kia models, and near OEM coverage for all other Asian marques. It also provides competitive coverage for many European and American vehicles – an area which is constantly being developed.

The sales and popularity of hybrid and electric vehicles has increased significantly over the last decade, with Asian manufacturers at the forefront. From the Toyota Prius and Nissan Leaf, to the latest Mitsubishi Outlander PHEV, plus new hybrid models due to arrive from Hyundai and Kia – the G-Scan2 has them covered.

With super-fast triple processors, a rapid boot-up time, a bright/clear HD touchscreen, built-in Wi-Fi.

Data Retrieval

The G-Scan2 Lite and Asian models include a built-in 4-channel oscilloscope with multi-meter and lead kit. The scope also has a floating-ground on 2-channel mode allowing voltage differentials with different grounds to be displayed – perfect for sensor testing.

Data Interpretation

The oscilloscope software has pre-sets and sample waveforms with guides and explanations to aid component fault-checking and diagnosis, as well as a signal simulator function which allows the technician to substitute sensor signals.

Coding and Special Functions

Whether you need to code/re-code a component, carry out a DPF regen or calibrate a new sensor, you know you're covered with the G-Scan2.

Job Recording

Data logging and record function allows the G-Scan2 to record up to 1 hour of live data for later playback and analysis. This can be reviewed as waveforms or as numerical figures and viewed on the G-Scan screen or on a PC using the PC Utility program. The PC utility is a very user-friendly interface which gives you access to the regular downloadable software updates, as well as saved screenshots and files from your G-Scan. It also allows you to create vehicle diagnostic reports which can be customised, saved or printed and given to the vehicle owner.



2 YEARS FREE SOFTWARE UPDATES AND 2 YEAR WARRANTY

G-SCAN 2 BASE
355 77 7650

WEEKLY FROM ONLY **£9.05⁺**
ONLY **£1,795.00**

G-SCAN 2 LITE
with Oscilloscope
355 77 4020

WEEKLY FROM ONLY **£12.07⁺**
ONLY **£2,395.00**

G-SCAN 2 ASIAN
Full Asian Package
355 77 4330

WEEKLY FROM ONLY **£13.58⁺**
ONLY **£2,695.00**

*Finance example typically based on a 5 year lease purchase agreement. Finance subject to status, full terms and conditions available on request. Other finance options available. All prices exclude VAT at 20%. Price, availability and specification may change without prior notice. Warranty subject to manufacturers terms and conditions of use. Errors and omissions excluded. Offers valid until 31st March 2017. Prices correct at time of going to press: December 2016.

0845 603 3636
OVER 200 BRANCHES NATIONWIDE

Selecting the right compressor

When selecting the right air compressor, the tank size is important. A small tank will overwork the motor. It is equally if not more important to select an air compressor that provides enough cubic feet per minute (cfm) of airflow. CFM is going to determine how many tools you can run, and whether each tool will function at its best.

TOOL/EQUIPMENT	CFM	BAR
3/8" Impact Wrench	2 – 3	6
1/2" Impact Wrench	4 – 6	6
3/4" Impact Wrench	9	6
1" Impact Wrench	14	6
3/8" Ratchet	2 – 5	6
1/2" Ratchet	5	6
3/8" Drill	12	6
DA Sander (Top Quality)	10	6
DA Sander (econ. model)	20	6
7" Sander/Polisher	25	6
Zip/Impact Cutter	4 – 5	6
Cutters Shears	4 – 8	6
4" Angle Grinder	18 – 25	6
7" Angle Grinder	25 – 35	6
Tyre Inflator	2 – 4	10 – 16
Tyre Changer (Manual)	4	10
Tyre Changer (Auto)	6	10
Sand Blast Cabinet	10 – 50	3.5 – 7

TOOL/EQUIPMENT	CFM	BAR
Sand Blast Hand Gun	8 – 12	7
Spray Gun – Airbrush	0.25	2
Spray Gun – Miniature	4 – 7	1.5 – 3.5
Spray Gun – Low Pressure	1.5 – 4	1.5 – 3
Spray Gun – Standard	7.14	3.5 – 4
Spray Gun – HVLP	14 – 20	5 – 6
HA/GEO/9000 series LVLP	7 – 9.5	2 – 2.5
Air Fed Mask	5 – 6	1.5 – 3
Oil Pump	1.5	7 – 10.5
Grease Pump	4.5	7 – 10.5
Air Water Wash	10	10.5
Car Wash	1.5 – 5	5 – 7
Blow Gun (safety nozzle)	3	7
Spark Plug Cleaner	3	7
Underseal Gun	4	7
Rivet Gun	1.5 – 3	50 – 6
2 Ton Air/Hydraulic Lift	5 – 8	9 – 10.5
Brake Tester	3 – 7	5 – 7
Plasma Cutter	6 – 8	4 – 7

PREVOST ALUMINIUM/PLASTIC PIPEWORK

If your air pipework is not a ringmain design, some of your compressor's best work is probably being lost to pressure drops between the compressor and the workstation. You may also be losing valuable air through leaks. Galvanised pipework inevitably corrodes, and air under pressure will always find the weak spots.

With our free design service, Workshop Solutions can supply and install a Prevost 'ringmain' aluminium and plastic pipework system which will deliver consistent pressure throughout the workshop, and never corrode.

- Leak-free networks
- Optimum flow rate – no pressure drop
- Lasting installations using corrosion-free aluminium
- Quick and easy maintenance
- Networks extendable as needed

SAVE ENERGY, GET MAXIMUM EFFICIENCY FROM YOUR COMPRESSOR

CALL FOR A QUOTE



*Finance example typically based on a 5 year lease purchase agreement. Finance subject to status, full terms and conditions available on request. Other finance options available. All prices exclude VAT at 20%. Price, availability and specification may change without prior notice. Warranty subject to manufacturers terms and conditions of use. Errors and omissions excluded. Offers valid until 31st March 2017. Prices correct at time of going to press: December 2016.

Compressors

NO HASSLE WARRANTY
BEST PRICE PROMISE

ABAC PRO PISTON COMPRESSORS

Ideal for a small workshop where only single phase is available.

Belt driven, resulting in a quieter and more efficient compressor

Typically used with Tyre Inflator, Blow Gun, Spray Gun, Impact/ Ratchet wrenches



**SPECIAL EDITION 25TH ANNIVERSARY MODEL
WHILST STOCKS LAST**

PRO A39B 150 FM3

572 77 0580



ONLY **£508.00**

PRO A39B 200 FM3

572 77 0560



ONLY **£562.00**

PRO B4900 200 FT4

572 77 0670

Perfect for a small workshop with three phase

Typically Used with Tyre Inflator, Blow Gun, Spray Gun, Impact/ Ratchet wrenches, low consumption shot blast cabinet



ONLY **£690.00**

PRO B5900B 200 FT5.5

572 77 0680

Perfect for a medium workshop with three phase



ONLY **£744.00**

PRO A39 270 FM3 TANDEM

572 77 0690

Ideal for a small workshop where only single phase is available. Largest single phase piston compressor available.

Belt driven, resulting in a quieter and more efficient compressor.



WEEKLY FROM ONLY **£6.53⁺**
ONLY **£1,295.00**

WILKINSON STAR WORKHORSE COMPRESSORS

Typically used with: Impact wrench, Ratchet wrench, Air chisel, underseal gun, tyre inflator

Ideal for a small workshop where only single phase is available



WORKHORSE WR3HP – 150SEC

572 77 1630



ONLY **£435.00**

WORKHORSE WR3HP – 200SEC

572 77 1670



ONLY **£488.00**

WORKHORSE WR4HP – 200SEC

572 77 1680



ONLY **£794.00**

Typically used with: Impact wrench, Tyre changer, Small DA Sander, brake tester

For the busier 2/3 man mechanical workshop where three phase is available



WORKHORSE 5.5HP – 200SEC

572 77 1690



ONLY **£859.00**

WORKHORSE WR5.5HP – 270SEC

572 77 1710



ONLY **£880.00**

WORKHORSE WR7.5HP – 270SEC

572 77 1740



WEEKLY FROM ONLY **£5.32⁺**
ONLY **£1,055.00**

WORKHORSE WR10HP – 200SEC

572 77 1750

Typically used with: Spray gun, DA Sander, Lift, 1" Impact wrench
For a commercial workshop / small bodyshop
Accident / Car panel Repair.



WEEKLY FROM ONLY **£7.72⁺**
ONLY **£1,532.00**

*Finance example typically based on a 5 year lease purchase agreement. Finance subject to status, full terms and conditions available on request. Other finance options available. All prices exclude VAT at 20%. Price, availability and specification may change without prior notice. Warranty subject to manufacturers terms and conditions of use. Errors and omissions excluded. Offers valid until 31st March 2017. Prices correct at time of going to press: December 2016.

Compressor Accessories

NO HASSLE
WARRANTY

BEST PRICE
PROMISE

ANTI-VIBRATION MOUNTS

592 77 2860

A set of 4 Anti-vibration mounts made of a large area damper material, designed to bolt between the compressor feet and the floor.

- Ensures quieter running
- Reduces the effect of motor vibration
- Extends compressor life



ONLY **£95.00**

ECOBBOX OIL WATER SEPARATOR

595 77 0250

The ECOBOX is an affordable condensate cleaning solution for piston or screw compressors with an output up to 60 cfm. It is designed to remove the oil traces from compressor condensate in line with Water Resources Act (1991) Chapter II, para 85, referring to an offence of knowingly polluting waters, by the disposal of poisonous, noxious or polluting matter.

- Economic
- Compact
- Environmentally friendly
- Quick and easy installation



ONLY **£76.00**

Do you have unwanted water and particulates within your compressed air system?

- Is water effecting your application at point of use?
- Are your tools failing and rusting due to water ingress?
- Are you tired of replacing filter elements?

The Original Dropout® is a unique, scientifically engineered, patent protected multi-stage Compressed Air Filter that removes 99.9999% of Water and 99% solid particulates down to 1 Micron. This unique multi-stage compressed air filter performance is constant regardless of the flow rate.

JUST DRAIN PERIODICALLY AND CONTINUE USING AT THE SAME HIGH EFFICIENCY

- Dropout provides a low maintenance, robust solution for unwanted water and particulates within your compressed air system
- Dropout requires no mains power to operate and can accommodate for pulsed flows or stop/start with instantaneous recovery
- Install Dropout at point of use to guarantee water free, clean air
- ISO 12500 accredited so you can be confident Dropout is as good as advertised



Match your Dropout to your compressed air output – start enjoying the benefits

ITEM DESCRIPTION	INLET/OUTLET CONNECTION	CFM MIN/MAX	BAR MIN/MAX	PART NUMBER	PRICE
DO300S	1/2" (f)	0.04 - 15	1 to 15	595 77 0250	£345
DO600S	3/4" (f)	0.04 - 30	1 to 15	595 77 0260	£410
DO900S	3/4" (f)	0.04 - 45	1 to 15	595 77 0270	£475
DO1500S	1" (f)	0.04 - 90	1 to 15	595 77 0280	£605

*Finance example typically based on a 5 year lease purchase agreement. Finance subject to status, full terms and conditions available on request. Other finance options available. All prices exclude VAT at 20%. Price, availability and specification may change without prior notice. Warranty subject to manufacturers terms and conditions of use. Errors and omissions excluded. Offers valid until 31st March 2017. Prices correct at time of going to press: December 2016.

Compressors

NO HASSLE WARRANTY
BEST PRICE PROMISE

WILKINSON STAR SILVER SCREW COMPRESSORS

- For applications where there is a constantly high demand for air power
- Powerful, efficient heavy duty belt drive motors
- Low noise levels



SILVER 10 300L

572 77 1870



WEEKLY FROM ONLY **£18.41⁺**
ONLY £3,652.00

SILVER 15 300L

572 77 1890



WEEKLY FROM ONLY **£24.02⁺**
ONLY £4,765.00

WILKINSON STAR SILVER D SCREW COMPRESSORS

- Refrigerated dryer option for clean, dry air production.
- Simple-to-use control units
- Enabling manage, monitor and optimise the machine's operation



SILVER D 10 300L

572 77 2080



WEEKLY FROM ONLY **£23.66⁺**
ONLY £4,695.00

SILVER D 15 300L

572 77 1910



WEEKLY FROM ONLY **£28.29⁺**
ONLY £5,613.00

SILVER D 20 300L

572 77 1930



WEEKLY FROM ONLY **£30.69⁺**
ONLY £6,090.00

2 YEAR CONDITIONAL WARRANTY
SUPPORTED BY FACTORY-TRAINED ENGINEERS

ABAC SPINN COMPRESSORS

SPINN 2.2KW

572 77 0270

Typical use: Spray gun, impact wrenches, tyre machines.
Single phase, low noise.



WEEKLY FROM ONLY **£13.46⁺**
ONLY £2,670.00



SPINN 4KW

572 77 0230

Typical use: Spray gun, impact wrenches, tyre machines.
Low noise, good quality air



WEEKLY FROM ONLY **£14.26⁺**
ONLY £2,830.00

Typical use: Spray guns, impact wrenches, tyre machines, sanders, air fed masks. Low noise, good quality air

SPINN 5.5KW

572 77 0710



WEEKLY FROM ONLY **£15.61⁺**
ONLY £3,098.00

SPINN E 5.5KW

572 77 0490



WEEKLY FROM ONLY **£18.58⁺**
ONLY £3,686.00

ABAC GENESIS COMPRESSORS

2 YEAR STANDARD WARRANTY
(SUBJECT TO MANUFACTURERS TERMS OF USE)*

GENESIS 7.5KW

572 77 0440

Typical use: Spray guns, impact wrenches, tyre machines, sanders, air fed masks.
Low noise, high output, good quality dry air, small footprint.



WEEKLY FROM ONLY **£24.78⁺**
ONLY £4,917.00



Typical use: Tyre Inflator, Blow Gun, Spray Gun, Impact/ Ratchet wrenches. Low noise, higher output for larger spray shops.

GENESIS 11KW

572 77 0180



WEEKLY FROM ONLY **£25.86⁺**
ONLY £5,131.00

GENESIS 15KW

572 77 0380



WEEKLY FROM ONLY **£26.94⁺**
ONLY £5,345.00

*Must be commissioned and serviced by an authorised distributor

*Finance example typically based on a 5 year lease purchase agreement. Finance subject to status, full terms and conditions available on request. Other finance options available. All prices exclude VAT at 20%. Price, availability and specification may change without prior notice. Warranty subject to manufacturers terms and conditions of use. Errors and omissions excluded. Offers valid until 31st March 2017. Prices correct at time of going to press: December 2016.

SUSPENDED WARM AIR OR RADIANT UNITS

Suspended unit heaters producing warm air or radiant heat. Suitable for showrooms, workshops, and bodysshops, and storage facilities. Off-floor mounting provides an ideal solution where floor space is at a premium.

- Ambi-Rad Gas Radiant Heaters - deliver exceptional efficiency and the potential to reduce energy costs.
- Ambi-Rad Ultra-Gas Warm Air Heaters – The ULTRA exceeds European norms for efficiency and the lowest NO_x and CO₂ emissions.
- RST Gas Heaters – available with heat outputs ranging from 41,000 Btu – 490,000 Btu for use on natural gas, or propane.
- OUH Oil Heaters – available in six heat outputs ranging from 105,000 Btu – 334,000 Btu, for use on Diesel oil. Alternatively, units may be specified for use with Kerosene.

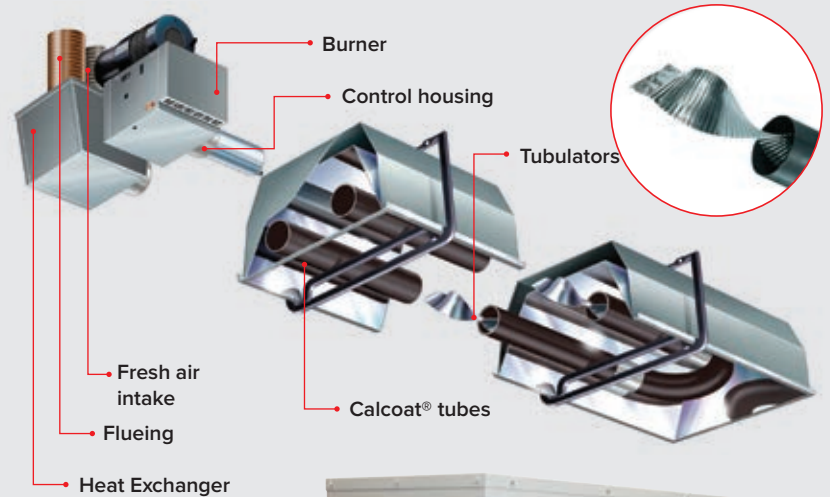

CALL FOR A QUOTE

We need an idea of the workshop size (height (eaves and apex), length and width) and how well insulated the building is. From that we can calculate the heat loss of the building and what heater output will be needed. If we also know where the services are and how the building is laid out so that the heating system will be sited in the right place, we can provide a detailed budget which will be verified by a site visit by one of our experienced team.

THERMOBILE PROHEAT OIL-FIRED CABINET HEATERS

For use with Diesel Heating Oil or Kerosene with Built-in Fuel Tank-perfect solution where there is no room for a bulk tank.

- Foursided adjustable outlet opening guarantees equal air distribution and connection for air duct
- Combustion chamber and heat exchanger of heat resistant steel
- Control panel fitted with switches and warning lights
- Standard equipped with summer/winter circuit for heating or ventilation



SUPPLIED WITH STANDARD FLUE KIT

PROHEAT 30

594 77 2920



WEEKLY FROM ONLY **£10.56⁺**
ONLY £2,095.00

PROHEAT 40

594 77 2930



WEEKLY FROM ONLY **£11.97⁺**
ONLY £2,375.00

PROHEAT 60

594 77 2940



WEEKLY FROM ONLY **£13.08⁺**
ONLY £2,595.00

PROHEAT 80

594 77 0900



WEEKLY FROM ONLY **£14.59⁺**
ONLY £2,895.00

*Heaters operating on Used Oil require a relevant permit under Schedule 13A of the Environmental Permitting Guidance (EPR). There will be requirements placed on emissions monitoring and operational control procedures.

*Finance example typically based on a 5 year lease purchase agreement. Finance subject to status, full terms and conditions available on request. Other finance options available. All prices exclude VAT at 20%. Price, availability and specification may change without prior notice. Warranty subject to manufacturers terms and conditions of use. Errors and omissions excluded. Offers valid until 31st March 2017. Prices correct at time of going to press: December 2016.

Heating – Oil Cabinets

NO HASSLE WARRANTY

BEST PRICE PROMISE

THERMOBILE SB RANGE UNIVERSAL OIL HEATERS

Free standing, auto ignition, virtually soot-free oil-burning* heaters, providing warm air heating suitable for automotive workshops.

Supplied complete with a flue kit and setup instructions, these heaters do not require specialist engineer installation. However, a qualified electrician will be required to make the final connection to a 3 Phase supply.

A built-in room thermostat enables automatic operation of the heater in order to obtain the desired room temperature and on a low position is extremely useful for overnight frost protection. An optional digital thermostat/timer control is also available.

SB40

594 77 1370



WEEKLY FROM ONLY **£19.65⁺**
ONLY £3,899.00

SB60

594 77 1380



WEEKLY FROM ONLY **£21.41⁺**
ONLY £4,249.00

SB80

594 77 1390



WEEKLY FROM ONLY **£30.23⁺**
ONLY £5,999.00

SB110

594 77 1400



WEEKLY FROM ONLY **£33.76⁺**
ONLY £6,699.00



SUPPLIED WITH STANDARD FLUE KIT

FLOWMATIC PNEUMATIC PUMP SYSTEM

594 77 1620

for bulk storage tanks with top outlets and/or for distances above 15m

ONLY **£795.00**

DIGITAL THERMOSTAT/TIMER

594 77 2490

energy management computer for extremely precise space heating control

ONLY **£199.00**

BSO OIL FIRED CABINET HEATERS

- For use with Diesel Heating Oil or Kerosene
- May be specified for either free blowing applications or for use with ductwork
- May be specified with high/low or fully modulating burners
- Require connection to bulk oil tank

BSO 30

594 77 0320



WEEKLY FROM ONLY **£10.58⁺**
ONLY £2,099.00

BSO 40

594 77 0300

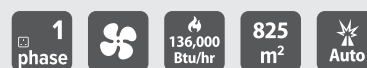

WEEKLY FROM ONLY **£11.33⁺**
ONLY £2,249.00

BSO 60

594 77 1420



WEEKLY FROM ONLY **£12.85⁺**
ONLY £2,549.00

BSO 85

594 77 0820



WEEKLY FROM ONLY **£13.60⁺**
ONLY £2,699.00

BSO 120

594 77 1430



WEEKLY FROM ONLY **£16.63⁺**
ONLY £3,299.00

FLUE KIT AVAILABLE FROM £280+VAT



*Heaters operating on Used Oil require a relevant permit under Schedule 13A of the Environmental Permitting Guidance (EPR). There will be requirements placed on emissions monitoring and operational control procedures.

*Finance example typically based on a 5 year lease purchase agreement. Finance subject to status, full terms and conditions available on request. Other finance options available. All prices exclude VAT at 20%. Price, availability and specification may change without prior notice. Warranty subject to manufacturers terms and conditions of use. Errors and omissions excluded. Offers valid until 31st March 2017. Prices correct at time of going to press: December 2016.

THERMOBILE UNIVERSAL OIL HEATERS

Floorstanding, manual ignition, virtually soot-free oil-burning* heaters. Suitable for general automotive workshops, the AT307 produces radiant heat, whilst the other models, being fan assisted, produce warm air heating.

Supplied complete with a flue kit and setup instructions, these heaters do not require specialist engineer installation. Enclosed-flame setup (not available on AT306 and AT307 Thermo) ensures odour-free and efficient combustion.

The high efficiency of the AT400 and AT500 is achieved by a built-in, large surface heat exchanger, through which all the gases have to pass before entering the flue.

SUPPLIED WITH STANDARD FLUE KIT

EXCLUSIVE 2 YEAR WARRANTY



AT306
594 77 1330



WEEKLY FROM ONLY **£5.03⁺**
ONLY £999.00



AT306 TERMO
594 77 1750



WEEKLY FROM ONLY **£5.79⁺**
ONLY £1,149.00



AT307
594 77 1340



WEEKLY FROM ONLY **£7.55⁺**
ONLY £1,499.00



AT400
594 77 1350



WEEKLY FROM ONLY **£10.58⁺**
ONLY £2,099.00



AT500
594 77 1360



WEEKLY FROM ONLY **£12.59⁺**
ONLY £2,499.00

FLUE BOOSTER

594 77 2260

The Heater Booster simply slots between the heater and the flue and increases the heater's output utilising the heat that would normally be lost through the flue.

- Suitable for models AT306, AT306T, AT307, AT400
- Simply slots into 150mm diameter flue pipe system
- A 220-240V supply is required for the fan

ONLY **£295.00**

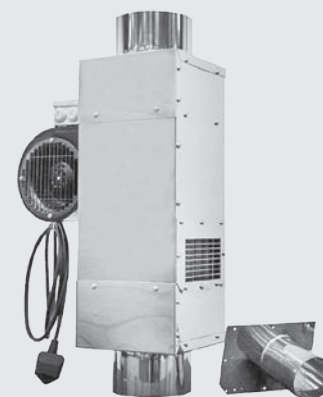

*Heaters operating on Used Oil require a relevant permit under Schedule 13A of the Environmental Permitting Guidance (EPR). There will be requirements placed on emissions monitoring and operational control procedures.

*Finance example typically based on a 5 year lease purchase agreement. Finance subject to status, full terms and conditions available on request. Other finance options available. All prices exclude VAT at 20%. Price, availability and specification may change without prior notice. Warranty subject to manufacturers terms and conditions of use. Errors and omissions excluded. Offers valid until 31st March 2017. Prices correct at time of going to press: December 2016.

HITON UNIVERSAL OIL HEATERS

Floorstanding, manual ignition, virtually soot-free oil-burning* heaters. Suitable for general automotive workshops, the HP105 produces radiant heat, whilst the other models, being fan assisted, produce warm air heating.

Supplied complete with a flue kit and setup instructions, these heaters do not require specialist engineer installation. Enclosed-flame setup ensures efficient combustion.

EXCLUSIVE 3 YEAR WARRANTY

SUPPLIED WITH STANDARD FLUE KIT



HP105
594 77 2280



ONLY **£899.00**



HP115
594 77 2290



WEEKLY FROM ONLY **£5.03⁺**
ONLY **£999.00**

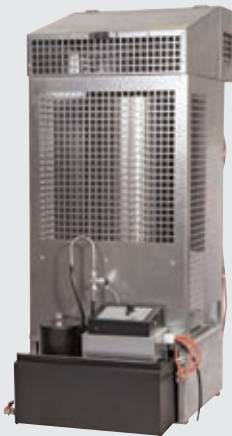

HP125
594 77 2310



WEEKLY FROM ONLY **£5.54⁺**
ONLY **£1,099.00**



HP135
594 77 2050



WEEKLY FROM ONLY **£6.80⁺**
ONLY **£1,349.00**

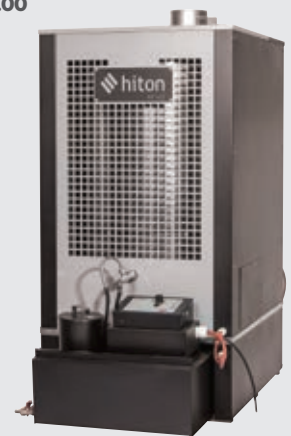

HP145
594 77 2030



WEEKLY FROM ONLY **£8.54⁺**
ONLY **£1,695.00**

FLUE BOOSTER

The Heater Booster simply slots between the heater and the flue and increases the heater's output by up to 10% utilising the heat that would normally be lost through the flue.

FOR HP105, 115, 125 AND 135
594 77 2320
FOR HP145
594 77 2330
ONLY **£250.00**

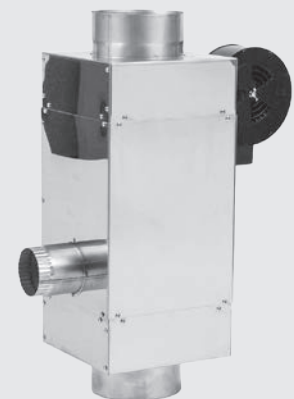

*Heaters operating on Used Oil require a relevant permit under Schedule 13A of the Environmental Permitting Guidance (EPR). There will be requirements placed on emissions monitoring and operational control procedures.

*Finance example typically based on a 5 year lease purchase agreement. Finance subject to status, full terms and conditions available on request. Other finance options available. All prices exclude VAT at 20%. Price, availability and specification may change without prior notice. Warranty subject to manufacturers terms and conditions of use. Errors and omissions excluded. Offers valid until 31st March 2017. Prices correct at time of going to press: December 2016.

SAFE SOLVENTS VIPER BRAKE AND CLUTCH WASHER

590 01 0250

The Viper is a break through parts washing machine designed to replace traditional brake and clutch cleaning equipment currently supplied on contract by the UK's major parts washing and waste collection businesses. Fully wireless and designed to easily glide around the workshop floor, without any cables/air lines to cause trip hazards. An inbuilt compressor and the pumping system allows you to wash and dry the brake assembly on a vehicle with ease. To make life even easier, the Viper height adjusts up and down by up to 40cms to suit your perfect working height.

- Easy to fill
- Self-draining.
- Uses Safe Solvents advanced cleaning liquid which is non-flammable, non-toxic and easy to dispose of.



WEEKLY FROM ONLY **£8.31***
ONLY **£1,649.00**

ADVANCED BRAKE 7 CLUTCH CLEANING FLUID 25L

590 01 0260



ONLY **£57.99**

CLEAR FLOW MANIFOLD AND INJECTOR CLEANING UNIT, SUITABLE FOR PETROL AND DIESEL VEHICLES

590 01 0060

- Clears contamination from fuel injection systems
- Special adaptors and products for cleaning manifolds without dismantling
- Works on petrol and diesel vehicles
- Comes with fittings for most vehicles



ONLY **£395.00**

TOP GUN DPF CLEANER ON VEHICLE DPF CLEANING UNIT

590 01 0070

- High pressure gun to press the top gun treatment into the DPF unit
- Works through removing one sensor
- Effective cleaning effect for the most contaminated DPF unit
- Robust and re-useable workshop tool



ONLY **£199.00**

*Finance example typically based on a 5 year lease purchase agreement. Finance subject to status, full terms and conditions available on request. Other finance options available. All prices exclude VAT at 20%. Price, availability and specification may change without prior notice. Warranty subject to manufacturers terms and conditions of use. Errors and omissions excluded. Offers valid until 31st March 2017. Prices correct at time of going to press: December 2016.

**KÄRCHER HDS 7/10-4 M
HOT WATER PRESSURE WASHER
240V STEAM MODE
546 77 1100**

- Superb performance for daily and deep cleaning jobs.
- Ecoefficiency mode, offers fuel savings of up to 20% without compromising cleaning performance
- 4-pole motors for high performance and long life
- On-board diagnostics, and 3-year burner coil warranty
- HDS middle class range provides toughness, cleaning power, and low running costs

CALL FOR DEMO



WEEKLY FROM ONLY **£9.57⁺**
ONLY **£1,899.99**

**KÄRCHER HDS 6/12 C
HOT WATER PRESSURE WASHER
WITH STEAM MODE
546 77 1740**

- State-of-the-art compact hot water high-pressure cleaner
- Unique ecoefficiency mode reduces diesel consumption by 20% without compromising daily cleaning performance
- Machine Protector system prolongs component life and provides a 3-year burner coil warranty
- Easy to set-up, intuitive to operate and cheap to run

CALL FOR DEMO



WEEKLY FROM ONLY **£7.55⁺**
ONLY **£1,499.99**

**KÄRCHER BR 40/10
FLOOR SCRUBBER
546 77 108D**

- Designed for heavy duty cleaning of small to medium floors
- Features two counter-rotating brushes and two rubber squeegees, ensuring floors are thoroughly cleaned and dried in a single pass
- With vacuum system turned off, machine can be used for deep cleaning of heavily soiled floors where more scrubbing and detergent are needed

CALL FOR DEMO



WEEKLY FROM ONLY **£6.55⁺**
ONLY **£1,299.99**

+ FREE

**KÄRCHER NT 20/1
WET AND DRY VAC
546 99 0810**

The robust, compact NT 20/1 Wet and Dry vacuum cleaner with 20-litre container reliably removes all kinds of dirt.

The machine is equipped with a 20-litre container and impresses with its Easy Service Concept, low operating and maintenance costs and reliable filter technology. With its powerful 1,500 Watt turbine, the vacuum cleaner makes light work of all types of dirt. The machine is ideal for small quantities of liquids, coarse dirt and dust.



WORTH £179 + VAT

*Finance example typically based on a 5 year lease purchase agreement. Finance subject to status, full terms and conditions available on request. Other finance options available. All prices exclude VAT at 20%. Price, availability and specification may change without prior notice. Warranty subject to manufacturers terms and conditions of use. Errors and omissions excluded. Offers valid until 31st March 2017. Prices correct at time of going to press: December 2016.

Oil Distribution and Draining

NO HASSLE WARRANTY **BEST PRICE PROMISE**

COMBINED WASTE OIL SUCTION & GRAVITY DRAINER 100LTR 536 77 0370

- High performance low noise vacuum pump
- Suction probe kit c/w flexible and rigid tubes
- Pressure discharged through low pressure hose
- Telescopic tube on drainer bowl
- Tray for tools, washers, plugs etc. on top of reservoir
- Oversized 360° positional composite extension tray for wider reach



ONLY **£499.99**

MOBILE WASTE OIL SUCTION & GRAVITY DRAINER 70LTR 536 77 0390

- High performance low noise vacuum pump
- Suction probe kit c/w flexible and rigid tubes
- Pressure discharged through low pressure hose
- Telescopic tube on drainer bowl



ONLY **£399.99**

MOBILE WASTE OIL RECEIVER 100LTR PUMP DISCHARGE 536 77 0410

- 1:1 ratio pump mounted to unit for oil discharge
- Telescopic tube on drainer bowl
- Tray for tools, washers, plugs etc. on top of reservoir
- Oversized 360° positional composite extension tray for wider reach



ONLY **£499.99**

OIL DISPENSING SYSTEMS

Air-operated oil dispensing system for barrels offers quicker, cleaner, and safer solutions that will improve efficiency in any workshop

- 3:1 oil dispensing pump with bung adaptor
- Drip tray – wall mounted
- Digital dispensing gun – pre select the exact amount of oil to dispense
- Pressure regulator and lubricator
- 12 month warranty



TROLLEY MOUNTED, WITHOUT HOSE REEL 592 01 0050

A nimble mobile dispensing solution. Heavy Duty four wheels trolley with rear brakes. Supplied with 4m of hose

ONLY **£630.00**



WALL MOUNTED 592 01 0030

Serving 2-3 workstations within a 15 metre radius. Supplied with 15m hose reel wall mounted with bracket.

ONLY **£735.00**



TROLLEY MOUNTED, WITH HOSE REEL 592 01 0040

Maximum flexibility from a mobile dispensing solution. Heavy Duty four wheels trolley with rear brakes. Supplied with 15m of hose reel.

ONLY **£735.00**

*Finance example typically based on a 5 year lease purchase agreement. Finance subject to status, full terms and conditions available on request. Other finance options available. All prices exclude VAT at 20%. Price, availability and specification may change without prior notice. Warranty subject to manufacturers terms and conditions of use. Errors and omissions excluded. Offers valid until 31st March 2017. Prices correct at time of going to press: December 2016.



NEED HELP MANAGING YOUR BUSINESS ACTIVITIES?

ECP Autowork Online can help you organise everyday tasks in your business.

ECP Autowork Online can assist you from generating quotes and invoices to maintaining service records and managing the diary. Integration with Euro Car Parts electronic catalogue enabling you to order parts online.



ECP Autowork Online

