

Workshop Solutions

One call for complete peace of mind



Garage Equipment, Tools,
Training & Technology

Valid until 31st December 2017



PICO AUTOMOTIVE DIAGNOSTICS KITS EVERYTHING FOR THE AUTOMOTIVE DIAGNOSTIC EXPERT

The Pico Automotive Diagnostics Kits work with your PC to measure and test virtually all of the electrical and electronic components and circuits in any modern vehicle including:

- Ignition (primary and secondary)
- Injectors and fuel pumps
- Starter and charging circuits
- Batteries, alternators and starter motors
- Lambda, airflow, ABS and MAP sensors
- Electronic throttle control
- CAN bus, LIN bus and FlexRay

PICO 4 CHANNEL STANDARD KIT IN CARRY CASE 355 77 1420



WEEKLY FROM ONLY **£8.54⁺**
ONLY **£1,695.00**

PICO MASTER KIT IN PLASTIC CARRYCASE PQ039 355 77 9590

PICO MASTER KIT IN FOAM TRAYS PQ040 355 77 9580



WEEKLY FROM ONLY **£20.13⁺**
ONLY **£3,995.00**

**EURO ACADEMY PICO TRAINING COURSE
NOW AVAILABLE
CALL BRANCH FOR DETAILS**

AVL DITEST SCOPE 1400

NEW

Digital, high-resolution 4-channel scope module for signal capture in motor vehicles. The retrieval of measurement results via connection to PC or tablet.



STANDARD SET 355 99 0470

- AVL DiTEST Scope 1400 Modul
- Power supply with cable
- USB cable
- 4 x cable URD
- 4 x test probes black
- 4 x test probes red
- 4 x crocodile clips red
- 4 x crocodile clips black
- Stimuli wire set
- Current clamp I100 Standard
- Current clamp I1800
- CD manual
- Transport case
- Packing

WEEKLY FROM ONLY **£13.08⁺**
FROM ONLY **£2,595.00**



HIGH END SET 355 99 0480

- AVL DiTEST Scope 1400 Modul
- Power supply with cable
- USB cable
- Cigarette lighter and vehicle battery supply
- Cable URD
- 4 x test probes red
- 4 x test probes black
- 4 x crocodile clips red
- 4 x crocodile clips black
- Stimuli wire set
- Current clamp I1500 High End
- Current clamp I1800
- Temperature sensor -20° to 200°C
- Pressure sensor -1bar to 100bar
- Trigger clamp
- KV clip
- CD manual
- Transport case
- Packing

WEEKLY FROM ONLY **£20.15⁺**
FROM ONLY **£3,999.00**

*Finance example typically based on a 5 year lease purchase agreement. Finance subject to status, full terms and conditions available on request. Other finance options available. All prices exclude VAT at 20%. Price, availability and specification may change without prior notice. Warranty subject to manufacturers terms and conditions of use. Errors and omissions excluded. Offers valid until 31st December 2017. Prices correct at time of going to press: October 2017.

LAUNCH EURO TAB
355 77 8080

NEW

EXCLUSIVE DEAL TO EURO CAR PARTS

The LAUNCH EURO TAB is a diagnostic tool with wide car model coverage, powerful test function, abundant special functions and accurate test data. The tool supports all ECUs on 12V car models with computer controlled fuel-injected engines, covering thousands of car models from more than 70 car manufactures from Europe, America and Asia.

The machine comes complete with a Wireless Wi-Fi printer, ensuring ultimate practicality in the busy workshop.

- Abundant special functions
- Wide car model coverage
- Powerful test function
- Online data
- One-click upgrade
- Extended functions
- Bluetooth, Wi-Fi, RJ45, HDMI available



WEEKLY FROM ONLY **£12.57***
ONLY **£2,495.00**

2 YEARS FREE SOFTWARE UPDATES

SMOKEPRO
355 77 0450

The Smoke Pro® Total Tech® is the essential tool for finding EVAP system leaks and many others including:

- | | |
|-------------------------------|--|
| • EGR Valves | • Door and window seals |
| • Gaskets, fittings and hoses | • Turbos and intercoolers |
| • MAP/MAF sensors | • Oil leaks |
| • Worn throttle shafts | • Cracked or broken plastic components |
| • Brake boosters | • Head and tail lamp housings |
| • Catalytic converters | • Cracked manifolds |
| • Central locking systems | • And many more! |
| • Diaphragms and seats | |



ONLY **£549.00**

*Finance example typically based on a 5 year lease purchase agreement. Finance subject to status, full terms and conditions available on request. Other finance options available. All prices exclude VAT at 20%. Price, availability and specification may change without prior notice. Warranty subject to manufacturers terms and conditions of use. Errors and omissions excluded. Offers valid until 31st December 2017. Prices correct at time of going to press: October 2017.

LAUNCH X431 PRO AND PRO3S

Based on the Android 5 operating system, the X431 Pro3S is the latest diagnostic tool from Launch.

With remote diagnostic features and a built-in social network, this tool encompasses the best in Launch technology and tablet computer usability.

Incorporating the best in already existing Launch diagnostic tools, the Pro3S can read and clear DTCs, read a car's data stream, perform actuation tests and much more, at lightning fast speeds.

Pro3S can perform diagnostics effectively on cars manufactured in Europe, America and Asia, and is compatible with all of their individual software; making the Pro3S one of the most reliable and all-encompassing diagnostic tools available on the market today.

Operates both wireless and bluetooth connectivity.

A built-in social network service enables users to connect to a community for help with diagnosis. Users also have access to a car database and repair tips, allowing for faster and more efficient performance.

- Full system diagnosis
- Data stream storage and re-display
- Service light resets
- Coding, reset and programming functions
- Diesel particulate filters regen/replacement
- Online technical support and advice
- Electronic parking brake reset
- Key/immobiliser coding
- VIN recognition, auto search
- Live data recording & multiple graphing
- Special functions for specific manufacturers
- Capable of 24v Heavy goods vehicle diagnosis – optional HD Truck module required Pro3S only

LAUNCH X431 PRO3S V2

355 77 5150

- Durable handheld tablet in protective silicone case.
- Easy to read & operate multi-touch capacitive LCD 10" screen.

WEEKLY FROM ONLY **£8.54⁺**
ONLY **£1,695.00**



LAUNCH X431 PRO V2

355 77 4860

- Durable handheld tablets in protective silicone case.
- Easy to read & operate multi-touch capacitive LCD 8" screen.

WEEKLY FROM ONLY **£6.02⁺**
ONLY **£1,195.00**

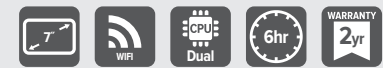

AUTEL MS908 PRO

355 99 0270

The MS908 has been the UK's best selling premier Autel diagnostic tool. Its capabilities are optimised even further with the release of the MS908Pro with our advanced J2534 pass through device included in the package. The J2534 opens up further programming capabilities for the MS908 via the manufacturer cloud. The MS908Pro also has further programming options directly within the tool software itself without the need to use manufacturer OEM software in some cases.

WEEKLY FROM ONLY **£12.57⁺**
FROM ONLY **£2,495.00**



*Finance example typically based on a 5 year lease purchase agreement. Finance subject to status, full terms and conditions available on request. Other finance options available. All prices exclude VAT at 20%. Price, availability and specification may change without prior notice. Warranty subject to manufacturers terms and conditions of use. Errors and omissions excluded. Offers valid until 31st December 2017. Prices correct at time of going to press: October 2017.

VCDS HEX

- Read and clear fault codes from all systems within the car, e.g. engine, airbag, ABS, instruments, parking sensors etc.
- View live data from the sensors within the car
- Reset service lights (both fixed and variable service intervals)
- Read stored and intermittent fault codes
- Graph and log live data with the car running
- Automatically read fault codes from all car systems in a single search
- Activate service functions, such as Electronic Park Brake (EPB) to allow brake pad changes
- Supports bi-directional output test and component actuation

VCDS software features:

- Over 20,820 fault code definitions
- Free software updates



VCDS HEX V2 - WIRED
355 99 0120



VCDS HEX NET - WIRELESS
355 99 0130

FROM ONLY **£425.00**

FROM ONLY **£495.00**

BRAIN BEE CONNEX

Diagnostic Software platform supplied complete with 10.1" Tablet Device and VCI dongle, or supplied with dongle only and software licence for operating with separate Windows or Android device.

Connex is a networked platform, connecting the user to the Brain Bee cloud with live updating, automatic VIN search, vehicle technical information, guided troubleshooting (optional) and real-time assistance (optional). The Connex tablet is a semi-rugged 10.1" touchscreen.



BRAIN BEE CONNEX CABLE

355 99 0250

WEEKLY **£7.55⁺**
FROM ONLY **£1,499.00**

BRAIN BEE CONNEX BLUETOOTH

355 99 0260

WEEKLY **£8.56⁺**
FROM ONLY **£1,699.00**

BRAIN BEE CONNEX SMART

355 99 0410

FROM ONLY **£849.00**

*Price shown does not include a subscription – a subscription is necessary to operate the device

*Requires Laptop. Laptop is not included.

| PART NUMBER | DESCRIPTION | PRICE |
|-------------|--|------------------|
| 356 77 7160 | BRAIN BEE CONNEX 12 MONTHS SOFTWARE SUBSCRIPTION | £620.00 |
| 356 77 7170 | BRAIN BEE CONNEX 36 MONTHS SOFTWARE SUBSCRIPTION | £1,465.00 |

G-SCAN 2

- All the outstanding capability and performance of the G-Scan, plus...
- Built in Oscilloscope excluding base model
- Digital Multimeter
- Super fast triple processor for high speed performance
- Communication line inspection function



2 YEARS FREE SOFTWARE UPDATES

2 YEARS WARRANTY

G-SCAN TAB

355 99 0160

ONLY **£895.00⁺**

G-SCAN 2 BASE

355 77 7650

WEEKLY **£9.05⁺**
FROM ONLY **£1,795.00**

G-SCAN 2 LITE

with Oscilloscope
355 77 4020

WEEKLY **£12.07⁺**
FROM ONLY **£2,395.00**

G-SCAN 2 ASIAN

Full Asian Package
355 77 4330

WEEKLY **£13.58⁺**
FROM ONLY **£2,695.00**

*Finance example typically based on a 5 year lease purchase agreement. Finance subject to status, full terms and conditions available on request. Other finance options available. All prices exclude VAT at 20%. Price, availability and specification may change without prior notice. Warranty subject to manufacturers terms and conditions of use. Errors and omissions excluded. Offers valid until 31st December 2017. Prices correct at time of going to press: October 2017.

J-BOX 2 PASS THRU DEVICE

355 77 1450

J-Box 2, a thoroughly capable Pass Thru device that can be used for repairs and general maintenance on the majority of vehicle marques.

Easy to install on your PC, this device will help reprogramme control modules in-house, ensuring you can keep custom in your garage without needing to send customers elsewhere.

- Support for over 36 OEM's
- How to videos included



WEEKLY FROM ONLY **£6.53⁺**
ONLY **£1,295.00**



EDIS TRUCK MULTIPLEXER + EDIS TRUCK SOFTWARE

355 99 0150

- Read and delete of error codes saved in the vehicle ECU
- Display and graph live vehicle data
- Adjust vehicle settings
- Activate devices and components
- Recode Electronic Keys
- Programme ECU's on many systems
- Log Data through EDIS internal memory card

Price includes EDIS Truck 12 months software subscription and 12 months Technical Support

*Requires laptop, laptop is not included.



WEEKLY FROM ONLY **£12.57⁺**
FROM ONLY **£2,495.00**



DURABOOK R11 RUGGED TABLET

355 77 9860

Ultra-thin and lightweight fully rugged tablet with 11.6" touchscreen. Equipped with a full array of communication options: WLAN, LAN, Bluetooth 4.0 (standard), 4G LTE and GPS (Optional modules), 5 Megapixel autofocus camera with LED flashlight. With 7 hours battery life. Robust features and superior performance the R11 is ideal for the workshop.

- 4G RAM
- Supplied with Windows 10
- Toughened touchscreen display
- Ultra light weight, only 1.2kg
- Processor speed 2.2 GHz
- Palm strap and stylus available (optional extra)



WEEKLY FROM ONLY **£7.03⁺**
ONLY **£1,395.00**



DURABOOK SA14S SEMI-RUGGED NOTEBOOK

355 77 3260

Full-function, tough and durable notebook with 14" HD LED display, Windows 10, and complete connectivity pack. Offers flexibility moving between the workshop and the desk.

- Supplied with Windows 10
- Rugged Features – IP53 and MIL-STD 810G certified.
- Built with high-quality magnesium alloy to withstand rough treatment.
- Advanced Touchscreen Display
- 8G RAM
- Processor speed 2.3 GHz
- 500GB HDD



WEEKLY FROM ONLY **£8.04⁺**
ONLY **£1,595.00**



*Finance example typically based on a 5 year lease purchase agreement. Finance subject to status, full terms and conditions available on request. Other finance options available. All prices exclude VAT at 20%. Price, availability and specification may change without prior notice. Warranty subject to manufacturers terms and conditions of use. Errors and omissions excluded. Offers valid until 31st December 2017. Prices correct at time of going to press: October 2017.

KTS560, KTS590

- Works with any Windows-based PC that has a licensed version of the Bosch diagnostics software ES[tronic]2.0 installed. Performs Pass Thru by working with OEM software*
- Operates OEM software with many approvals already in place
- Supports all of today's relevant diagnostic protocols including Diagnostics over Internet Protocol (DoIP) – and that means it's capable of all the latest OEM procedures
- USB2.0 and Bluetooth® connections means you can either stay tethered or not – your choice.
- The KTS 590 also includes a 2-channel oscilloscope, which means that not only voltage and current waveforms can be shown, but can also be immediately evaluated.

KTS560
355 77 9240

WEEKLY FROM ONLY **£9.05⁺**
ONLY **£1,795.00**



KTS590
WITH BUILT-IN OSCILLOSCOPE
355 77 9220

WEEKLY FROM ONLY **£11.06⁺**
ONLY **£2,195.00**



BLUETOOTH WIRELESS

ASK FOR A DEMO



*ESI subscription required.
Minimum spec. Windows7 and above.

DCU100 TABLET
355 77 9830

BLUETOOTH WIRELESS

- Ergonomic rubberised handgrips enables easier handling
- Robust Design: Suitable to work in any workshop conditions
- Integrated Bluetooth (Class 1) enables mobility and minimises cable clutter in the workshop
- Wifi enabled: Allowing web access
- SD card slot : Provides flexibility for data transfer
- Lithium-ion battery and easy to engage standby button: Prolongs the battery life



ALL NEW HARDWARE – GREAT FOR THE MOBILE TECH!

WEEKLY FROM ONLY **£9.02⁺**
ONLY **£1,790.00**



SUPERFAST BOOT-UP AND PROCESSING

*ESI subscription required

DCU 220
355 99 0190

BLUETOOTH WIRELESS

Carefully thought out details make operation easier

- Easily switched from tablet to notebook mode – continue to work as you change
- Sturdy housing with 11.6" touchscreen monitor – view more data in one go
- Integrated camera: Document and use to show customers or order parts photographed

Mobile work over extended periods

- Inclusion of two identical lithium-ion batteries
- If required, batteries can be replaced without interruption (hot swap function)



WEEKLY FROM ONLY **£14.09⁺**
ONLY **£2,795.00**



*ESI subscription required

*Finance example typically based on a 5 year lease purchase agreement. Finance subject to status, full terms and conditions available on request. Other finance options available. All prices exclude VAT at 20%. Price, availability and specification may change without prior notice. Warranty subject to manufacturers terms and conditions of use. Errors and omissions excluded. Offers valid until 31st December 2017. Prices correct at time of going to press: October 2017.

KTS560+DCU100
355 77 9830 + 355 77 9240

BLUETOOTH WIRELESS

PACKAGE DEAL

VCI (KTS560)

- Works with any Windows-based PC that has a licensed version of the Bosch diagnostics software ESI[tronic]2.0 installed. Performs Pass Thru by working with OEM software*
- Operates OEM software with many approvals already in place
- Supports all of today's relevant diagnostic protocols including Diagnostics over Internet Protocol (DoIP) – and that means it's capable of all the latest OEM procedures
- USB2.0 and Bluetooth® connections means you can either stay tethered or not – your choice.
- Rugged design with high resistance to dust and water

TABLET (DCU100)

- Ergonomic rubberised handgrips enables easier handling
- Robust Design: Suitable to work in any workshop conditions
- Integrated Bluetooth (Class 1) enables mobility and minimises cable clutter in the workshop
- Wifi enabled: Allowing web access
- SD card slot : Provides flexibility for data transfer
- Lithium-ion battery and easy to engage standby button: Prolongs the battery life

SAVE £295



KTS560

DCU100

*ESI subscription required

WEEKLY FROM ONLY **£17.61***
ONLY **£3,495.00**

BUY A KTS460 + STANDARD 12 MONTH ESI SUBSCRIPTION AND GET AN UPGRADE TO 12 MONTH MASTER SUBSCRIPTION

KTS350
355 77 9850

WIRED

ALL IN ONE VCI + TABLET

NEW

The new KTS 350 is a compact all-in-one tester consisting of a 10-inch tablet PC and an integrated communication module.

Thanks to this versatile solution, the KTS 350 is ideally suited as a tester for independent workshops, fast fitter or as a second device for mobile use. With the preinstalled Bosch diagnostic application ESI[tronic] 2.0, the KTS 350 provides an efficient overall package for control unit diagnosis, maintenance, troubleshooting and repair.

- Supports the new, Ethernet-based data protocols and is therefore perfectly prepared for the future demands of the automotive environment.
- Supports the PassThru Technology. This allows you to reprogram vehicle ECUs via OEM portals (separate subscriptions from each OEM required).
- Improved processor and modern SSD technology means a quick system start and fast working.
- Equipped with Windows 10 which means you can install additional applications. This means it can be easily integrated in your existing workflows.



*ESI subscription required

WEEKLY FROM ONLY **£17.61***
ONLY **£3,495.00**

BUY A KTS350 AND STD. 12 MONTHS ESI SUBSCRIPTION AND GET ESI MASTER 12 MONTH SUBSCRIPTION

*Finance example typically based on a 5 year lease purchase agreement. Finance subject to status, full terms and conditions available on request. Other finance options available. All prices exclude VAT at 20%. Price, availability and specification may change without prior notice. Warranty subject to manufacturers terms and conditions of use. Errors and omissions excluded. Offers valid until 31st December 2017. Prices correct at time of going to press: October 2017.

ESI[TRONIC] 2.0

ESI[tronic] 2.0 software is used in conjunction with the KTS range of diagnostic tools for vehicle fault diagnosis and service function procedures. The range of features available through the software is truly vast.

THE MAIN ESI PACKAGE ARE:

SD Diagnostics

Enables users to:

- Read Fault codes
- Erase Fault codes
- Collect Actual Data Values
- Actuate Components
- Carry out Function Tests
- Carry out service functions such as service lights, dpf, handbrakes, batteries and windscreens
- Carry out some coding

SIS Trouble shooting

Identifying a fault code is just the tip of the iceberg in a vehicle repair process. Trouble shooting is the solution to guide you to the root cause of the problem. It can guide the user from the fault code, real time data or symptoms through a number of tests to the root cause of the problem. It integrates the multimeter and scope (fitted to the KTS) to the guided diagnostics. SIS gives the user all of this in addition to the base SD package.

MP Master Pack

Trouble shooting takes users to the root cause, but users will need:

- Wiring diagrams for body electrics
- Technical bulletins
- Installation information
- Mechanical and service information
- Torque settings
- Locations and pin information on components

ESI STANDARD SUBSCRIPTION

SD Diagnostics / SIS Trouble shooting

SAVE £443

ONE YEAR

356 77 1580+356 77 1660

ONLY **£896.00**

THREE YEARS

356 77 1590+356 77 1670

WEEKLY FROM ONLY **£11.31⁺**
ONLY **£2,245.00**

ESI MASTER SUBSCRIPTION

SD Diagnostics / SIS Trouble shooting / MP Master Pack

SAVE £553

ONE YEAR

356 77 1580+356 77 1600

WEEKLY FROM ONLY **£5.65⁺**
ONLY **£1,121.00**

THREE YEARS

356 77 1590+356 77 1610

WEEKLY FROM ONLY **£14.16⁺**
ONLY **£2,810.00**

EXPERIENCE-BASED REPAIR (EBR) – KNOWN FIXES

UNIQUE IN THE MARKET

EBR-Finder

Bosch developed an innovative algorithm which enables the so called EBR-Finder to identify trending vehicle problems from a multitude of sources – using this as input, the experienced Bosch SIS-authors create a repair solution.

EBR MAKES TROUBLESHOOTING SIMPLE

- Add this unique information type to your normal ESI[tronic] 2.0 subscription and make your daily troubleshooting even easier than before
- If you are not yet registered for the EBR information type, the complete database listing of known fixes will be locked until the EBR license has been activated
- To benefit from the new ESI[tronic] 2.0 EBR information type, please contact your local sales agent.

ONE YEAR MASTER PACK INC EBR

356 77 1800 + 356 77 1580

WEEKLY FROM ONLY **£6.38⁺**
ONLY **£1,266.00**

THREE YEAR MASTER PACK INC EBR

356 77 1810 + 356 77 1590

WEEKLY FROM ONLY **£16.10⁺**
ONLY **£3,195.00**

SAVE £603

THE NEW INFORMATION TYPE FOR ESI[TRONIC] 2.0 USERS FIND THE RIGHT SOLUTION WITHIN SECONDS – EVEN FOR CHALLENGING TROUBLESHOOTING

CONTINUOUS IMPROVEMENT

Feedback function

The feedback function at the bottom of each repair instruction allows you and other ESI[tronic] diagnostic experts to rank and view the ratings of the selected solution. This indicates how popular the solution is and makes the search even simpler with the most common solutions listed at the top.



*Requires TSB/Master Pack Subscription

*Finance example typically based on a 5 year lease purchase agreement. Finance subject to status, full terms and conditions available on request. Other finance options available. All prices exclude VAT at 20%. Price, availability and specification may change without prior notice. Warranty subject to manufacturers terms and conditions of use. Errors and omissions excluded. Offers valid until 31st December 2017. Prices correct at time of going to press: October 2017.

HELLA GUTMANN MEGA MACS PC

355 77 5520 + 356 77 6750

- Suitable for your Windows netbook, PC or Tablet
- Comprehensive in-depth vehicle coverage
- Equipped with PassThru® technology
- DOIP Capable



WEEKLY FROM ONLY **£8.45⁺**
ONLY **£1,676.00**



MEGA MACS 42SE

355 77 4350

- Compact and lightweight diagnostic tool
- Comprehensive in-depth vehicle coverage
- Equipped with PassThru® technology
- Comes complete with Bluetooth adapter for remote printing and a docking/charging cradle
- Comprehensive onboard technical data
- DOIP capable



WEEKLY FROM ONLY **£12.35⁺**
ONLY **£2,450.00**



MEGA MACS 56

355 77 4720

REAL-TIME REPAIR ASSISTANCE

- Wi-Fi and Bluetooth connectivity enable wireless printing. Downloads technical data quickly and easily even whilst in use.
- PassThru® ready
- HGS Technical Data technical data included
- Comprehensive onboard technical data
- DOIP capable



WEEKLY FROM ONLY **£17.61⁺**
ONLY **£3,495.00**



MEGA MACS 66

355 77 8750

REAL-TIME REPAIR ASSISTANCE

- Diagnostics of all components, with instructions
- Interactive coloured circuit diagrams with depiction of actual values and parameters in real-time.
- Sets new standards in speed and accuracy of diagnosis
- Comprehensive onboard technical data
- DOIP capable



WEEKLY FROM ONLY **£23.94⁺**
ONLY **£4,750.00**



*Finance example typically based on a 5 year lease purchase agreement. Finance subject to status, full terms and conditions available on request. Other finance options available. All prices exclude VAT at 20%. Price, availability and specification may change without prior notice. Warranty subject to manufacturers terms and conditions of use. Errors and omissions excluded. Offers valid until 31st December 2017. Prices correct at time of going to press: October 2017.

AUTOLOGIC ASSIST

- Autologic Assist is the industry's first fully integrated diagnosis support system combining dealer-trained technician expertise with state-of-the-art technology and access to online databases of third party vehicle information.
- Assistplus Is The Cloud-Connected Diagnostics Device
- Assist support is the real-time access to Autologic's 50+ European dealer-trained master technicians, plus the simultaneous integration of data resources that joins expert knowledge and service.

REAL-TIME ASSISTANCE

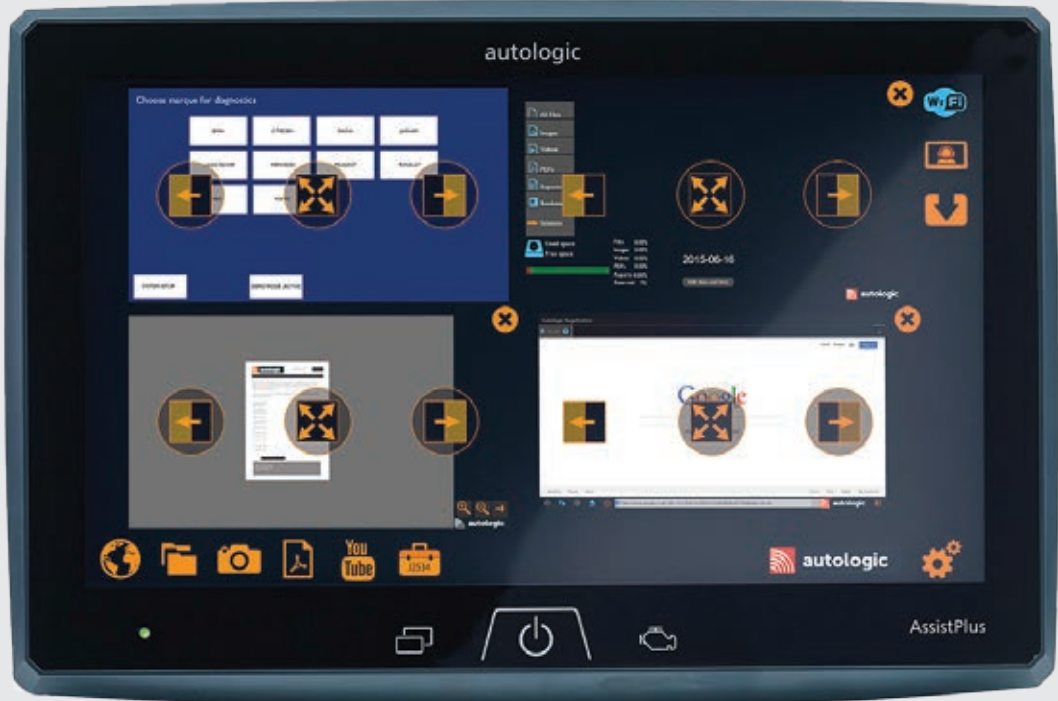

AUTOLOGIC ALLOWS DIRECT ACCESS TO ITS EXPERT FAULT 2 FIX SERVICE TEAM

AUTOLOGIC ASSIST AND SUPPORT
355 77 4730 + 356 77 7000

WEEKLY FROM ONLY **£47.86⁺**
ONLY **£9,500.00**

AUTOLOGIC ASSIST AND 3 YEARS SUPPORT
355 77 4730 + 356 77 7230

WEEKLY FROM ONLY **£63.00⁺**
ONLY **£12,500.00**

REAL-TIME ASSISTANCE MEANS TECHNICIANS RECEIVE HANDS ON REPAIR ADVICE & FIX SOLUTIONS ON REQUEST

CALL YOUR LOCAL BRANCH FOR AN UNBEATABLE OFFER

CASE STUDY

VEHICLE: 2011 PEUGEOT 508 AUTO

SYMPTOMS
The symptoms of this vehicle went from intermittent to near permanent where no gears could be selected. No matter the position of the selector the letter 'N' remained on the instrument cluster resulting in the car being un-drivable. The owner of the car had been informed by main dealer that the car required a new gearbox after they had inspected the long list of fault code which were stored in the transmission module.

AUTOLOGIC
Autologic Assist was used to give a second opinion. A full vehicle scan was performed which highlighted some 20+ permanent fault codes stored within the TCM, all returned when the vehicle was restarted. The technician had some experience with AT but in the back of the mind a dealer stating gearbox replacement required perhaps hindered his thought process so it was decided to forward the scan to the assist team.

SOLUTION
Minutes later we received a call from Carlos on Autologic's PSA Team, he explained how the fault codes were generated causing a 'Domino Effect' cascading many other codes. This is in most cases caused by the accumulator on the rear of the gearbox. Replacing this was sure to cure the fault. The accumulator was replaced, fault codes cleared and did not return. The car now drives perfectly.

*Finance example typically based on a 5 year lease purchase agreement. Finance subject to status, full terms and conditions available on request. Other finance options available. All prices exclude VAT at 20%. Price, availability and specification may change without prior notice. Warranty subject to manufacturers terms and conditions of use. Errors and omissions excluded. Offers valid until 31st December 2017. Prices correct at time of going to press: October 2017.



IF YOU CAN'T FIX A CAR IN 20 MINS, EURO ACADEMY IS THE SOLUTION!

**ANY
CUSTOMER**

**ANY
DIAGNOSTIC DEVICE**

**ANY
VEHICLE MANUFACTURER**

A MASTER TECHNICIAN AT A PRESS OF A BUTTON

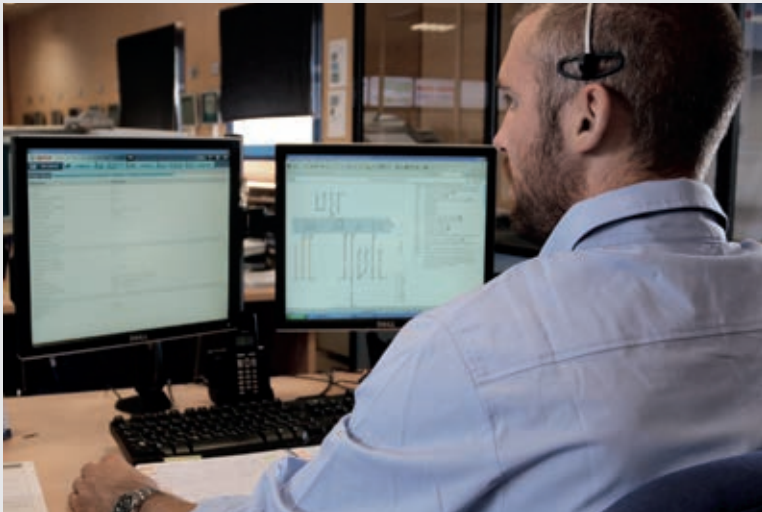

EURO ACADEMY MEMBERSHIP NOW OFFERS YOU ACCESS TO SUPERB TECHNICAL INFORMATION AND ASSISTANCE IN 3 DIFFERENT WAYS:



TECHNICAL HELPLINE



ONLINE FAULT LIBRARY



TRAINING FACILITY

Euro Academy Technical helpline is like having a master technician standing next to you. Unlike some of our competitors

- **NO LIMIT** to the amount of time you can spend on a call
- **NO LIMIT** to the number of times you can call us
- **EXPERIENCED** based fault diagnostics from 1000's of customers Our team of master technicians have years of practical experience along with access to the latest technical information on any vehicle, regardless of the manufacturer.

So whether you're looking for repair manuals, circuit diagrams, parts catalogues or component locations for any vehicle in your workshop, simply pick up the phone and let us help. One simple call to our technical helpline could save you hours of searching for an elusive component failure.

YOUR MEMBERSHIP

Becoming a Euro Academy member is an investment in your business, and one which will increase revenue and profits while saving time and money. Memberships are available by annual subscription paid monthly, and start from as little as £79.00 for level 1 subscribers.

FROM
ONLY **£79.99**

CONTACT YOUR LOCAL BRANCH FOR MORE DETAILS

*Finance example typically based on a 5 year lease purchase agreement. Finance subject to status, full terms and conditions available on request. Other finance options available. All prices exclude VAT at 20%. Price, availability and specification may change without prior notice. Warranty subject to manufacturers terms and conditions of use. Errors and omissions excluded. Offers valid until 31st December 2017. Prices correct at time of going to press: October 2017.

0845 603 3636
OVER 200 BRANCHES NATIONWIDE

EURO ACADEMY TRAINING COURSES

Euro Academy training courses cover all areas of mechanical, electrical, electronic and diagnostics fault-finding and repair over the entire vehicle for members.

We offer a structured solution that spans all ability levels from Basic to Master Technician; in fact, it's all the training your business will ever need. Technicians achieve career development from Euro Academy training, gaining qualifications that prove they are competent to repair customers' vehicles.

Each subject is covered by eight hours of e-learning, accessed wherever and whenever it suits the technician, and eight hours of on-site practical training.

- On-site training takes place at a venue determined by the location of the trainees, and is restricted to no more than 10 technicians at a time.
- Course content is continually re-assessed and is aligned to the Euro Vehicle Troubleshooting online Helpline – as the database grows, these known faults and repairs are incorporated into the syllabus, to keep the training up to date and give technicians the information they need.
- Practical training can be held in Euro Academy's new IMI Approved Centre, where all training sessions are IMI Quality Assured.

COURSE DURATION: 2 DAYS BLENDED TRAINING

- **On-site:** 8 hours of practical training
- **E-learning:** 8 hours accessed wherever and whenever it suits the technician

ELECTRICITY AND ELECTRONICS

IMI ACCREDITED

Understanding the basic principles of electricity is a pre-cursor to any mechanic looking to up his game and move towards a diagnostic / fault finding career path. Without the basics, it is impossible to safely and effectively diagnose today's increasingly complex range of vehicles.

MULTIMETER AND OSCILLOSCOPE (HIGH LEVEL)

IMI ACCREDITED

Having grasped the basics of electricity, most mechanics will want to keep feeding their knowledge. This section takes a more detailed look at the procedures involved to be able to test and verify the many sensors and actuators found in modern vehicles. Also, as a result of more complex digital electronics, new high-speed networks (CAN, LIN, MOST) have had to be implemented.

Euro Academy Members – call 0845 603 3636 or email training@eurocarparts.com to sign in to the course you need.

DIAGNOSIS

IMI ACCREDITED

A prudent and wise mechanic will retain their customers with a proper diagnostic process, by using the skills that they have learnt, to not only replace parts, but to ensure the part that they are replacing is the cause of the problem. In this section the student will be introduced to a methodology that they will use on a daily basis.

PETROL INJECTION

IMI ACCREDITED

Gain a thorough understanding of fuel systems and how emission control standards are met. Fuel, ignition and air intake systems work hand in hand with post-ignition treatment of exhaust gases to achieve or surpass these stringent regulations. The mechanic will gain an insight as to how these systems operate and begin to successfully test and diagnose petrol injection system faults.

DIESEL INJECTION

IMI ACCREDITED

With almost 50% of all UK car sales diesel engine vehicles, this training offers an invaluable insight and introduction to basic mechanical systems, and up-to-the minute common-rail high pressure systems including the necessary safety and cleanliness requirements.

**Need more courses than your membership entitlement?
Additional courses only £299.00 per day**

AIR CONDITIONING

IMI ACCREDITED

Understand the basic operating principles and the components involved in the air conditioning, in order to be able to safely diagnose operating defects. F-gas certificate is a prerequisite.

BRAKES – LEVEL 1 & BRAKES – LEVEL 2

IMI ACCREDITED

An introduction to hydraulic circuits and components to mechanical and electrically operated handbrake systems. Safety and awareness regarding the cleanliness and contamination of brake fluid and brake warning lamps is also paramount. An overview of ABS/ESP systems and the diagnosis of errors, using diagnostic tools is then introduced.

SUSPENSION

IMI ACCREDITED

Often the importance of a correctly operating and well maintained suspension system is disregarded. This can lead to premature tyre wear and dangerously increase stopping distances. The student will be introduced to the various elements that make up traditional and active suspension systems, and how they work in conjunction with each other, including how to spot common failure areas.

STEERING

IMI ACCREDITED

Power assisted steering is now commonplace on almost all vehicles. However, before repair, a thorough understanding as to the safety and operating principles of standard non-power assisted steering must be applied. Also included - hydraulic, electric and rear steer systems.



BOSCH TRAINING COURSES*

As the world's largest supplier of advanced electronic automotive systems, vehicle manufacturers from around the world rely on Bosch for innovation and technical expertise.

BOSCH COURSE VENUES

- | | |
|--------------|------------------|
| 1. Avonmouth | 5. Motherwell |
| 2. Blackburn | 6. Painton |
| 3. Bristol | 7. Uxbridge |
| 4. Doncaster | 8. Wolverhampton |

ONLY
£159.00
PER DAY



AVONMOUTH BOSCH COURSES* PROGRAMME

| COURSE CODE | COURSE TITLE | VENUE NAME | START DATE | DURATION DAYS |
|-------------|---|--|------------------------------|---------------|
| VSC28 | Steering Geometry & Four Wheel Alignment | Euro Academy Training Centre - Avonmouth | Wednesday, October 18, 2017 | 1 |
| VSC6 | Braking & Chassis Systems, ABS & ESP | Euro Academy Training Centre - Avonmouth | Wednesday, October 25, 2017 | 2 |
| VSD12 | Essential Diesel Knowledge | Euro Academy Training Centre - Avonmouth | Tuesday, November 07, 2017 | 2 |
| VSD15 | Common-Rail System Diagnosis | Euro Academy Training Centre - Avonmouth | Tuesday, November 14, 2017 | 2 |
| VSD16 | Unit Injector System Diagnosis | Euro Academy Training Centre - Avonmouth | Wednesday, November 29, 2017 | 1 |
| CS1 | Customer Care | Euro Academy Training Centre - Avonmouth | Thursday, November 30, 2017 | 1 |

FULL COURSE DESCRIPTIONS AND NATIONWIDE SCHEDULES AVAILABLE AT YOUR LOCAL BRANCH

CALL YOUR LOCAL BRANCH FOR THE LATEST NEWS ON COURSE DATES

*External courses are not included within the Euro Academy Membership entitlement and are charged separately.

*Finance example typically based on a 5 year lease purchase agreement. Finance subject to status, full terms and conditions available on request. Other finance options available. All prices exclude VAT at 20%. Price, availability and specification may change without prior notice. Warranty subject to manufacturers terms and conditions of use. Errors and omissions excluded. Offers valid until 31st December 2017. Prices correct at time of going to press: October 2017.

AUTODATA

Autodata is the comprehensive and trusted online tool, designed to provide quick and easy access to technical information to efficiently carry out complex diagnostics and repair procedures, as well as day-to-day servicing and maintenance operations. Genuine manufacturer data, delivered in an easy-to-use and consistent format, covering 136 vehicle manufacturers and 32,000 models worldwide.

- Full service and maintenance procedures
- Data embedded directly into service schedules
- Interactive coloured wiring diagrams
- Fast and easy diagnostics and troubleshooting
- Interactive component location
- Comprehensive technical data and specifications

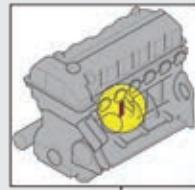

FREE 14 DAY TRIAL

| DESCRIPTION | PART NUMBER | PRICE PER MONTH* |
|---|-------------|------------------|
| AUTODATA, SERVICE & MAINTENANCE SUBSCRIPTION PACKAGE | | |
| 1 USER | 256 77 1450 | £43.75 |
| 2 USERS | 256 77 1490 | £50.33 |
| 5 USERS | 256 77 1510 | £61.25 |
| AUTODATA, DIAGNOSTIC & REPAIR SUBSCRIPTION PACKAGE | | |
| 1 USER | 256 77 1370 | £73.00 |
| 2 USERS | 256 77 1520 | £84.00 |
| 5 USERS | 256 77 1530 | £102.00 |

*Minimum 12 month contract

HELLA GUTMANN HGS DATA

356 77 6470

The complete vehicle technical database, accessible through any internet-enabled PC, with information and repair solutions for over 38,000 vehicles. With HGS Data you can access all the technical data you require for virtually any service or repair job, all at the touch of a button.

Technical specifications for over 38,000 vehicle models, as well as maintenance plans, engine control, ABS, airbag and thermal management data, updated repair aids and wiring diagrams are all covered

- 2 logins per subscription from any online device
- Technical data for over 38,000 vehicles
- Circuit diagrams
- Air bag, thermal management and engine control data

ONLY **£499.00**



*Finance example typically based on a 5 year lease purchase agreement. Finance subject to status, full terms and conditions available on request. Other finance options available. All prices exclude VAT at 20%. Price, availability and specification may change without prior notice. Warranty subject to manufacturers terms and conditions of use. Errors and omissions excluded. Offers valid until 31st December 2017. Prices correct at time of going to press: October 2017.

ALLDATA REPAIR

NEW

You pride yourself on doing the job, so start with the right information. ALLDATA doesn't alter the OEM data, so you get exactly what you need from each manufacturer – all in one easy-to-use portal.

Automotive repair shops using ALLDATA improve repair quality and accuracy, save time and money and meet manufacturer standards, improving customer satisfaction and business profitability.

- Manufacturer Electrical Wiring Diagrams
- Factory Technical Service Bulletins
- Factory mechanical repair procedures
- Trouble codes and diagnostic test charts
- OEM filling quantities
- Factory chassis repair instructions
- Factory maintenance interval and service schedules
- Factory tightening torques

WHY YOU NEED ORIGINAL MANUFACTURER INFORMATION

Technical data for the aftermarket needed to diagnose and repair today's complex vehicles is difficult to obtain or unavailable. To stay competitive and to maintain quality standards, you need access to a single source of original manufacturer repair information.

With ALLDATA Repair®, designed by automotive experts, technicians can easily search and find in-depth technical repair information to repair vehicles correctly, save time and improve customer satisfaction.



FEATURES AND BENEFITS

- OEM repair information direct from the manufacturer including 22 brands and 28 million articles of unedited and original repair articles in a comprehensive online portal. Available in five languages, you have access to an easy-to-use navigation structure and search to save you time, increase efficiency, and improve overall profitability.
- Access to the industry's largest source of OEM information online 24/7.
- With original manufacturer maintenance, diagnostic and repair information, you save time and money, and can repair vehicles to quality standards, and drive repeat business.
- Access to the most current manufacturer information so you can repair the newest vehicles on the road and ensure every repair is profitable.
- Common navigation across all brands and advanced search capability make it easy to find the information you need quickly and efficiently.

**ENTER "ECP WS" CODE
FOR YOUR FREE 2 WEEK TRIAL**

**1 USER
12 MONTH SUBSCRIPTION
256 77 1770**

MONTHLY FROM ONLY £69.00

**3 USER
12 MONTH SUBSCRIPTION
256 77 1760**

MONTHLY FROM ONLY £83.00

**ADDITIONAL USER
OVER 3 LICENSES PER MONTH
256 77 1780**

MONTHLY FROM ONLY £15.00

*Finance example typically based on a 5 year lease purchase agreement. Finance subject to status, full terms and conditions available on request. Other finance options available. All prices exclude VAT at 20%. Price, availability and specification may change without prior notice. Warranty subject to manufacturers terms and conditions of use. Errors and omissions excluded. Offers valid until 31st December 2017. Prices correct at time of going to press: October 2017.

0845 603 3636
OVER 200 BRANCHES NATIONWIDE

Auto Transmission Fluid Exchange

NO HASSLE
WARRANTY

BEST PRICE
PROMISE

With the high proportion of automatic vehicles on the road, it makes sense to keep Auto Transmission Fluid Exchange services in-house. Making simple work of scheduled service interval fluid changes, an automatic transmission fluid exchanger also offers a clean 'first option' for fixing problems including 'sealed for life' boxes. A simple flush and refill can often cure the problem and is an easy option to sell before going to the expense of a full strip-out at a specialist.

LAUNCH CAT501S

590 00 1060

The CAT-501S offers a range of automatic functions to exchange transmission fluid with minimal fuss and involvement. May also be used in a manual operation. The CAT-501S is supplied with a full set of connectors.

- 5" LCD display
- Oil exchange and level adjustment
- Print out the procedure and more vehicle data
- Monitoring of oil temperature
- Monitoring of oil pressure
- Empty fluid tank without disassembly
- Choose between 68 pieces universal adapters kit and bespoke UK adapters kit
- Online database access included
- 2 year warranty

The majority of manufacturers recommend changing the ATF fluid on automatic gearboxes every 30,000 to 40,000 miles.

Any of these symptoms below can be made better by a 100% ATF fluid flush and refill

- Rough gear change during acceleration
- Slow or delayed gearshifts
- Difficult to move from Park to Drive/Reverse
- Noisy gear changes or loud transmission running noise
- An increase in transmission vibrations felt inside the cabin

An ATF flush and refill produces the following benefits

- Smoother gear change
- Reduced transmission noise
- Easier gear selection
- Reduced transmission vibrations
- Faster up-shift during acceleration



WEEKLY FROM ONLY **£14.09⁺**
ONLY **£2,795.00**

*Return on investment example is not a guarantee of earnings. Based on 1 service per week charged out at £ 250 +vat

ASK FOR A DEMO



| | COSTS/ REVENUE |
|----------------------------|-------------------|
| SERVICE TO GARAGE CUSTOMER | £250.00 |
| COST OF FLUSH | -£8.50 |
| COST OF FLUID | -£90.00 |
| LABOUR AND OVERHEADS | -£25.00 |
| PROFIT PER SERVICE | £126.00 |

PAYS FOR ITSELF IN JUST 6 MONTHS
FROM JUST ONE SERVICE PER WEEK*

*Finance example typically based on a 5 year lease purchase agreement. Finance subject to status, full terms and conditions available on request. Other finance options available. All prices exclude VAT at 20%. Price, availability and specification may change without prior notice. Warranty subject to manufacturers terms and conditions of use. Errors and omissions excluded. Offers valid until 31st December 2017. Prices correct at time of going to press: October 2017.



Act first and get the biggest return

ASK FOR A DEMO

Despite ADAS (Advanced driver-assistance systems) technology already being in the mainstream, the majority of garage workshops don't yet have the equipment to complete an ADAS calibration following a repair.

This means there is an opportunity for those who act first to establish themselves not only with the traditional work providers, but also with other local collision repair workshops and the regular mechanical shops.

Getting kitted out with ADAS calibration equipment is a matter of a consultation with one of our Workshop Equipment Specialists. Our professional team will advise on site, arrange a demo, and lay out the options.

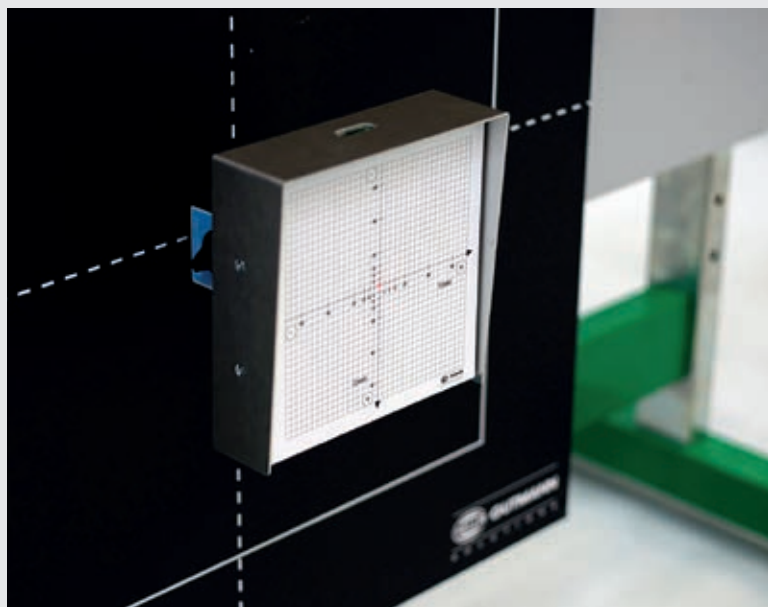
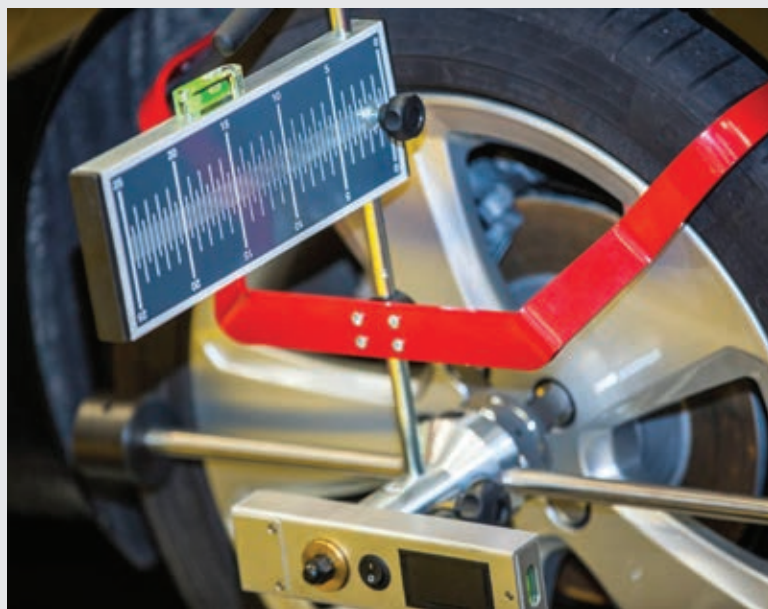

| DESCRIPTION | PRICE |
|-----------------------------------|------------------|
| Full CSC Tool Investment | £18,745 |
| Invoice Price Per Calibration | From £250 |
| Calibrations Per Week | 3 |
| Labour Rate Per Hour | £45 |
| Calibrations Needed To Break-even | 76 |
| Weeks To Pay Back | 25.3 |

PAYS FOR ITSELF IN JUST 6 MONTHS*

First mover advantage into ADAS calibration will get you making profit whilst the marketplace is still relatively uncompetitive. It will ensure you are already known for it in your area even when the competition picks up. Investing in ADAS equipment will also leave you best placed to integrate any new developments that come later down the line, ensuring you're not playing catch up with the competition.

With ADAS sensor initialisation and calibration a requirement on the many cars for numerous operations previously considered simple, such as replacing a door mirror or a bumper reinforcement beam, the call for this capability is undoubtedly going to grow rapidly and the first people in will reap the biggest reward.

Remember, a vehicle returned to the owner uncalibrated leaves you running the risk of being liable should the car be involved in an accident.

CSC Tool Includes – CSC Calibration Tool, All 9 Available Boards, Radar Kit 1 & 2, Rear Cam I Basic, Rear Cam I Addition, Rear Cam II Side and Hella MM56 Diagnostic Tool. 30min Labour Taken Into Account Per Calibration

*ROI calculation is based on purchase of - CSC Calibration Tool, All 9 Available Boards, Radar Kit 1 & 2, Rear Cam I Basic, Rear Cam I Addition, Rear Cam II Side and Hella MM56 Diagnostic Tool 30min Labour Taken Into Account Per Calibration. ROI calculation is not a guarantee of earnings. 30min Labour Taken Into Account Per Calibration. ROI calculation is not a guarantee of earnings.

Our Workshop Solutions Equipment Specialists are available to arrange a demo, and help deliver your ideal ADAS calibration solution – give us a call.

*Finance example typically based on a 5 year lease purchase agreement. Finance subject to status, full terms and conditions available on request. Other finance options available. All prices exclude VAT at 20%. Price, availability and specification may change without prior notice. Warranty subject to manufacturers terms and conditions of use. Errors and omissions excluded. Offers valid until 31st December 2017. Prices correct at time of going to press: October 2017.

Camera & Radar Calibration

NO HASSLE WARRANTY

BEST PRICE PROMISE

HELLA CSC TOOL

The Hella Gutmann CSC (Camera and Sensor Calibration) Tool enables effective and accurate calibration of a wide range of camera-based driver assist systems.

Whilst the CSC tool provides out-of-the-box coverage for calibrating VAG and Mercedes-Benz ADAS cameras, additional target panels are available separately for extending vehicle coverage to 19 manufacturers. Furthermore, over and above ADAS camera calibration, the Hella CSC tool is unique in offering ADAS radar calibration as well. Making this the most comprehensive ADAS calibration system available.

- Comprehensive Aftermarket solution for Camera and Radar Calibration
- Covering 19 OEM manufacturers
- Modular system to enable new systems and vehicles to be added
- New, Side and Rear calibration extension kits for 360 degree and rear systems
- Training included
- Interfaces with any mega macs diagnostic kit
- Full print out of a successful calibration, including date/time/VIN and Registration number
- Future proofs your business and creates a one stop solution for ADAS vehicles.



DELIVERY CHARGES APPLY

FREE WORKSHOP SIGNAGE



*image for illustration purposes only.

IDEAL FOR ALL MAKES GARAGES, GLASS REPLACEMENT BUSINESSES AND BODY SHOPS, AND COMPATIBLE WITH A WIDE RANGE OF VEHICLE MODELS AND CAMERA-BASED DRIVER ASSIST SYSTEMS

*ROI calculation is based on purchase of CSC Calibration Tool, All 9 Available Camera Target Boards, Radar Calibration Kits 1 & 2, and Hella MM56 Diagnostic Tool. ROI calculation is not a guarantee of earnings.

ASK FOR A DEMO

| DESCRIPTION | PART NUMBER | WEEKLY | PRICE |
|--|-------------|----------------|---------------|
| CSC Tool with Standard Camera Target Panels (Covers VAG and Mercedes) | 597 77 5760 | £28.48* | £5,650 |
| Radar 1 Calibration Kit (Covers VAG, Mercedes, BMW) | 597 77 7890 | £8.37* | £1,660 |
| Radar 2 Calibration Kit (Covers Mercedes 2nd Gen sensor) | 597 77 7880 | £6.27* | £1,245 |
| Camera Target Panels (6) (Covers Renault, Nissan, Honda, Toyota, Hyundai, Kia) | 597 77 7900 | £11.72* | £2,325 |
| Camera Target Panel (Covers Honda) | 597 77 8480 | - | £490 |
| Camera Target Panel (Covers later Toyota/Lexus) | 597 77 8490 | - | £490 |
| Camera Target Panel (Covers Subaru) | 597 77 8510 | - | £490 |
| CSC - Kit Rear Cam I Basic | 597 77 9370 | £7.01* | £1,390 |
| CSC - Kit Rear Cam I Addition | 597 77 9380 | - | £690 |
| CSC - Kit Rear Cam II Side | 597 77 9390 | - | £790 |

*Finance example typically based on a 5 year lease purchase agreement. Finance subject to status, full terms and conditions available on request. Other finance options available. All prices exclude VAT at 20%. Price, availability and specification may change without prior notice. Warranty subject to manufacturers terms and conditions of use. Errors and omissions excluded. Offers valid until 31st December 2017. Prices correct at time of going to press: October 2017.



ATE FB5E ELECTRIC BRAKE BLEEDER

400 776 940

- Meets vehicle manufacturer requirements & 2.0 bar pre-selectable pressure levels
- Designed for 5-litre ATE container – no need to transfer brake fluid
- Holders for filling hose, mains cable three bleeding spigots
- Large handle for carrying the unit comfortably
- Access to the most current manufacturer information so you can repair the newest vehicles on the road and ensure every repair is profitable.
- Common navigation across all brands and advanced search capability make it easy to find the information you need quickly and efficiently.
- Supplied with Universal adaptor that meets most popular vehicles



ONLY **£349.00**

ATE FB30 ELECTRIC BRAKE BLEEDER

590 01 1310

- Fast and effective through fixed pressure stages
- Manual selection of pressure between 0.4-3.5bar
- Suitable for all common brake and clutch systems
- Extraction of used brake fluid with a robust pump
- Extendable 3m long coil to access difficult reservoirs
- Constant working pressure thanks to electronic pressure control EDR
- Suitable for different brake fluid cans (5, 20 & 30L)
- Automatic switch off & acoustic warning signal when can is empty
- Holders for power cable, filling hose & six bleeding spigots
- Supplied with Universal adaptor that meets most popular vehicles



ONLY **£530.00**

ATE FB30SR MOBILE ELECTRIC BRAKE BLEEDER

590 01 1290

Specification as per FB30 but added advantages include

- Base plate prevents unsightly scratches caused by brake fluid cans
- Large wheels at the front and swivel casters at the rear make safe and convenient manoeuvring even with a full 30L can
- Supplied with Universal adaptor that meets most popular vehicles



ONLY **£779.00**

ATE BLEEDER ADDITIONAL ADAPTORS SET

590 01 0580

Set of four of the most common standard bleeding unit adapters for Asian vehicles and cap screws for fluid reservoir in a handy plastic case.

Adapters:

- No. 31A
- No. 61A
- No. 77A
- No. 86A

Cap screws:

- No. 67



ONLY **£265.00**

*Finance example typically based on a 5 year lease purchase agreement. Finance subject to status, full terms and conditions available on request. Other finance options available. All prices exclude VAT at 20%. Price, availability and specification may change without prior notice. Warranty subject to manufacturers terms and conditions of use. Errors and omissions excluded. Offers valid until 31st December 2017. Prices correct at time of going to press: October 2017.

Emission Analysers

NO HASSLE WARRANTY **BEST PRICE PROMISE**

PREMIER DIAGNOSTIC

5 YEARS PREMIER COMBI EMISSIONS ANALYSER FOR LESS THAN THE PRICE OF ONE MOT TEST

Premier Diagnostics combi emissions tester and the operational training, plus 5 years total care (excluding consumables) in one easy package. With the equipment, and the maintenance, care and warranty all taken care of, all you have to do is just test! The 5 Years total package includes DVSA software updates (consumables e.g. oxygen sensor, filters, printer paper not included)

Full 5 years warranty includes – parts and labour, covering all major parts including PC, Gas Bench, Smokehead, Printer, Monitor, Keyboard and Mouse, plus 5 years calibrations.

British built combined petrol and diesel emission analyser with integrated oil temperature and unique RPM measurement technology

- 5 Years Emissions Solution consists of a Premier Combi analyser and 5 Years Care Package
- Premier Combi analyser is equipped with Wi-Fi enabled PC with flexibility to run own programmes, CD Rom, 17" colour monitor, keyboard, mouse and printer
- Every MOT test is stored to memory for instant retrieval and automatic printout of results
- Cable-less smokehead is Euro 6 compliant for a future-proofed investment
- Fast nationwide on-site support by dedicated UKAS accredited engineers
- EOBD, RPM, and Oil Temperature Kit are fully compliant to latest DVSA guidelines
- British designed and manufactured

ASK FOR A DEMO



PREMIER COMBI EMISSIONS ANALYSER WITH 3YR WARRANTY/CALIBRATIONS
588 01 0200

WEEKLY FROM ONLY **£29.48⁺**
FROM ONLY **£5,850.00**

WITH 5YR WARRANTY/CALIBRATIONS
588 77 0090

WEEKLY FROM ONLY **£42.71⁺**
FROM ONLY **£8,475.00**

PREMIER DIAGNOSTICS 5 YEARS EMISSIONS TOTAL SOLUTION FOR LESS THAN THE PRICE OF ONE MOT TEST

BOSCH EMISSIONS

New generation premium combi emissions solutions designed for efficiency and high demand usage.

Offered in three configuration options, the new Bosch emissions line-up offers everything in the set-up that best suits you to quickly and cost-effectively test petrol and diesel vehicles. The perfect solution to current and future demands of workshops.

BEA 950 S1: COMBI EMISSIONS ANALYSER WITH TROLLEY AND PC
588 01 0530

All measurement modules, control unit testers plus a PC, 19" monitor, keyboard and A4 printer in one compact package on a trolley.



WEEKLY FROM ONLY **£31.73⁺**
FROM ONLY **£6,295.00**

BEA 950 S3: COMBI EMISSIONS ANALYSER WITH TROLLEY – USE YOUR OWN PC/LAPTOP
588 01 0540

Measurement modules and control unit testers supplied on a trolley ready for Bluetooth connection to an existing tablet or laptop.



WEEKLY FROM ONLY **£29.21⁺**
FROM ONLY **£5,795.00**

BEA 550: COMBI EMISSIONS FOR MOBILE OPERATION
588 01 0550

Quick and easy to set up in both mobile and workshop environments for precise testing of petrol and diesel vehicles. This makes the BEA 550 with its compact shape and low weight a perfect companion for flexible emissions testing.



WEEKLY FROM ONLY **£29.69⁺**
FROM ONLY **£5,890.00**

*Laptop/Tablet (e.g. Bosch DCU100) required to operate

*Finance example typically based on a 5 year lease purchase agreement. Finance subject to status, full terms and conditions available on request. Other finance options available. All prices exclude VAT at 20%. Price, availability and specification may change without prior notice. Warranty subject to manufacturers terms and conditions of use. Errors and omissions excluded. Offers valid until 31st December 2017. Prices correct at time of going to press: October 2017.



Emission Analysers - Crypton

NO HASSLE WARRANTY

BEST PRICE PROMISE

CRYPTON EMISSION ANALYSER

Includes:

3 YEARS WARRANTY



23" Colour Screen



Digital smoke meter with automatic calibration



Oil Temperature Probe



Printer, mouse & keyboard with dust/grease protection



Battery RPM Measurement



Gas Analyser accurate to OIML class 0

Crypton's Combined Gas and Smoke Emissions Analyser is one of the very best around. With a robust design, it is perfect for handling the harshest garage environment.

- Complies to the latest DVSA regulations
- Links directly to the DVSA online system
- Test vehicle classes IV, V & VII (petrol & diesel)
- Operates the brake tester (when purchased)
- Housed in a quality, mobile cabinet
- Available in cabled or wireless
- Manufactured and supported in the UK

CCP800 CABLED
588 01 0060

WEEKLY FROM ONLY **£21.42⁺**
ONLY £4,250.00

CCP800 WIRELESS
588 01 0070

WEEKLY FROM ONLY **£24.44⁺**
ONLY £4,850.00

WHY NOT UPGRADE TO 5YEAR EXTENDED CARE?

- Parts
- Routine consumables
- MOT updates
- Labour
- Calibrations

WEEKLY FROM ONLY **£16.12⁺**
FROM ONLY £3,199.00



*Finance example typically based on a 5 year lease purchase agreement. Finance subject to status, full terms and conditions available on request. Other finance options available. All prices exclude VAT at 20%. Price, availability and specification may change without prior notice. Warranty subject to manufacturers terms and conditions of use. Errors and omissions excluded. Offers valid until 31st December 2017. Prices correct at time of going to press: October 2017.

0845 603 3636
OVER 200 BRANCHES NATIONWIDE

OPTL PACKAGES

A One Person Test Lane requires a lift equipped with play detectors. Originally, the OPTL option was only designed as an upgrade to the traditional 2-man test lane when equipment was ready for changing, or to improve the profitability on labour costs. However, nowadays, OPTL lift and brake tester packages are sometimes the first choice for a new site as they offer, in exchange for some reduced functionality in the brake tester, some cost savings against a full ATL lift and brake tester package. An OPTL brake tester is not equipped with the axle weighing capability of a full ATL brake tester.



Configure your OPTL Package

CALL FOR A QUOTE!

1. CHOOSE YOUR LIFT

4 POST LIFTS

- **Class IV** available with platform lengths 4300mm, 4600mm, 5200mm
- **Class VII** available with platform lengths from 5200mm, 5700mm, 6500mm



SCISSOR LIFTS

- **Class IV** available with platform lengths 4300mm, 4600mm, 5200mm
- **Class VII** available with platform lengths 5200mm, 5700mm, 6500mm



2. CHOOSE YOUR BRAKE TESTER

STANDARD

- **Standard Brake Tester** – dials and no weighing



COMPUTERISED

- **Computerised Brake Tester** – electronic monitor and no weighing



CLASS IV 4 POST OPTL PACKAGE

WEEKLY FROM ONLY **£95.75⁺**
FROM ONLY **£18,999.00**

CLASS IV SCISSOR OPTL PACKAGE

WEEKLY FROM ONLY **£120.93⁺**
FROM ONLY **£23,995.00**

CLASS VII 4 POST OPTL PACKAGE

WEEKLY FROM ONLY **£120.93⁺**
FROM ONLY **£23,995.00**

CLASS VII SCISSOR OPTL PACKAGE

WEEKLY FROM ONLY **£143.89⁺**
FROM ONLY **£28,549.00**

*Finance example typically based on a 5 year lease purchase agreement. Finance subject to status, full terms and conditions available on request. Other finance options available. All prices exclude VAT at 20%. Price, availability and specification may change without prior notice. Warranty subject to manufacturers terms and conditions of use. Errors and omissions excluded. Offers valid until 31st December 2017. Prices correct at time of going to press: October 2017.

✔ BEST CHOICE, ✔ BEST BRANDS, ✔ BEST PRICES

TECALEMIT



CLASS IV 4 POST PACKAGES FROM £21,999

2 YEAR WARRANTY

LIFTMASTER



CLASS IV 4 POST PACKAGES FROM £21,249

ASK ABOUT THE LIFTMASTER ROLLING WARRANTY FOR THE LIFE OF THE BAY!

BRADBURY



CLASS IV 4 POST PACKAGES FROM £21,409

3 YEAR WARRANTY

WERTHER



CLASS IV 4 POST PACKAGES FROM £20,999

SUPPLIED WITH HEADLAMP TESTER UPGRADED TO LASER

CRYPTON



CLASS IV 4 POST PACKAGES FROM £22,399

3 YEARS WARRANTY/INCLUDES INTEGRATED EMISSIONS ANALYSER

JOHN BEAN



CLASS IV 4 POST PACKAGES FROM £26,799

2 YEARS WARRANTY/INCLUDES INTEGRATED EMISSIONS ANALYSER

*Installation to a prepared site, excludes building/electrical works, warranty is subject to maintenance, exclusions apply.

*Finance example typically based on a 5 year lease purchase agreement. Finance subject to status, full terms and conditions available on request. Other finance options available. All prices exclude VAT at 20%. Price, availability and specification may change without prior notice. Warranty subject to manufacturers terms and conditions of use. Errors and omissions excluded. Offers valid until 31st December 2017. Prices correct at time of going to press: October 2017.

HEADLAMP TESTERS

Also available in a 'service' version for pre-MOT preparation. The DVSA approved headlight beam tester come in two options: mirror visor (analogue), or laser (digital). They are supplied with a standard length of rails, (additional rail lengths are available as a further option). Engineer installation is included to a prepared sites.



ANALOGUE HEADLAMP TESTER
(including installation)
586 77 0130

ONLY **£849.00**



LASER HEADLAMP TESTER
(including installation)
586 77 0150

WEEKLY ONLY **£5.29⁺**
ONLY **£1,049.00**

MAJORLIFT JACKING BEAMS

**EXCLUSIVE WORKSHOP SOLUTIONS
SUPPLIED WITH 95MM RAISER BLOCKS
within the package**

The Complete Package supplied as standard (includes arms*, delivery, and 95mm raiser blocks.)

- Supplied with a 1700mm double-extending top beam as standard – **NEW FEATURE**
- Provides 260mm of lift as standard – **NEW FEATURE**
- Low height to suit vehicles with low clearance
- Support arms available to suit all makes of lift
- Support arms included to suit all makes of lift*
- Ultra-low jacking position
- 5-year warranty



**EXCLUSIVE FREE INSPECTION
LAMP WITH EACH JACKING
BEAM PACKAGE**

MANUAL 2.0T
579 77 0460

ONLY **£835.00**

MANUAL 2.8T
579 77 0490

WEEKLY FROM ONLY **£6.02⁺**
ONLY **£1,195.00**

AIR OPERATED 2.0T
579 77 0510

WEEKLY FROM ONLY **£5.54⁺**
ONLY **£1,099.00**

AIR OPERATED 2.8T
579 77 0520

WEEKLY FROM ONLY **£7.05⁺**
ONLY **£1,399.00**

Support arms included to suit all makes of lift*

*Finance example typically based on a 5 year lease purchase agreement. Finance subject to status, full terms and conditions available on request. Other finance options available. All prices exclude VAT at 20%. Price, availability and specification may change without prior notice. Warranty subject to manufacturers terms and conditions of use. Errors and omissions excluded. Offers valid until 31st December 2017. Prices correct at time of going to press: October 2017.

OUR SPECIALIST EQUIPMENT SERVICE AND MAINTENANCE TEAM PROVIDES ALL INSTALLATION, SERVICING AND MOT CALIBRATION REQUIREMENTS INCLUDING PLANNED MAINTENANCE AND SCHEDULING

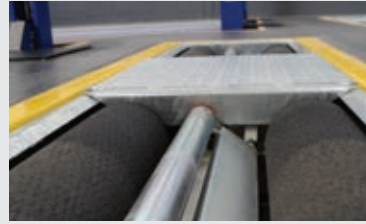
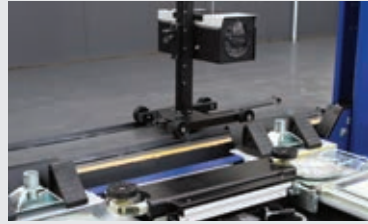

SPECIAL OFFER – GET YOUR AIRCON MACHINE SERVICED AT THE SAME TIME AS YOUR BOSCH OR CRYPTON EMISSIONS CALIBRATION FOR ONLY £ 150 PLUS PARTS!*

*offer applies only to Bosch or Crypton emissions analysers

PLANNED MAINTENANCE

A preventative maintenance contract can provide a significant reduction in repair costs, ensuring total peace of mind for both the equipment owner and operator. Alternatively, services can be secured on 'as required' basis.

| PLANNED MAINTENANCE | | FROM |
|---|--|------------------|
| Vehicle Lift Maintenance & Repairs | Single Post, 2 Post, 4 Post, Scissor Lift Servicing and Repair | £55.00** |
| JACKING BEAM REPAIR | | CALL |
| Air & Oil Pipework | Supply and installation including galvanised steel tube, Transair and John Guest aluminium | CALL |
| Spraybooth Servicing | Complete spraybooth service including certification and testing | £287.50 |
| Compressor Servicing | Service support for compressed air systems excluding parts | £117.00** |
| Air Conditioning Machine Servicing | Service support and maintenance facility including repairs, training and F-gas assessments | £205.00 |
| WELDING EQUIPMENT SERVICING | | £30.00 |
| Spray Gun Repairs | For a variety of spray guns regardless of manufacturer carried out in fast response time | CALL |
| Waste Collection | Variety of waste collections for various quantities | CALL |

The above prices do not include any parts that may be needed.

BREAKDOWN RESPONSE

Regardless of whether or not we have been maintaining your equipment on a service contract, you can take advantage of our prompt breakdown repair service. We understand the urgency of the situation and will dispatch most efficiently.

| BREAKDOWN RESPONSE | | FROM |
|---|---|----------------|
| Vehicle Lifts call out and repair | 2 Post, 4 Post, Scissor Lift | £100.00 |
| Air Conditioning Machine call out and repair | All Makes call out and repair | £75.00 |
| Welding Equipment repair | Spot and Mig Welders, Plasma Cutters, Induction Heaters, TKR Riveters, Oxy/Acet Equipment, Dent Pullers | £30.00 |
| Compressors call out and repair | All Makes call out and repair | £115.00 |

The above prices do not include any parts that may be needed.

CALIBRATION SERVICES

Once you give us your calibration contract, our database tracks when your MOT equipment is due – so your calibration will always be timely. Using only suitably accredited engineers, we aim to minimise equipment down-time.

| CALIBRATION SERVICES | | FROM |
|--------------------------------------|--|----------------|
| MOT Equipment Calibration | For both Car and Motorcycle equipment | £150.00 |
| Tyre Changer & Balancer | Alignment Systems calibrations | £140.00 |
| Emission Analyser Calibration | Scheduled calibrations | £330.00 |
| Tools Calibration | For a wide variety of tools including tyre gauge, torque wrench, pressure gauge, paint thickness & tracking sticks | CALL |
| Paint Scales Calibration | All Makes Paint Scales calibration | £75.00 |

The above prices do not include any parts that may be needed. Minimum charge for tool calibrations, prices above don't include admin or travel fee. Yearly calibration (2 gas, 1 smoke).

CERTIFICATION & TESTING

We will carry out your required inspections and issue the necessary certificates.

| CERTIFICATION & TESTING | | FROM |
|--|--|---------------|
| LEV Exhaust Ventilation System Test & Certification | | £90.00 |
| Spraybooths Smoke Clearance Test & Certification | | £56.25 |
| Spraybooths Breathing Air Quality Test | | £95.00 |

**Minimum quantity applies

The above prices do not include any parts that may be needed.

*Finance example typically based on a 5 year lease purchase agreement. Finance subject to status, full terms and conditions available on request. Other finance options available. All prices exclude VAT at 20%. Price, availability and specification may change without prior notice. Warranty subject to manufacturers terms and conditions of use. Errors and omissions excluded. Offers valid until 31st December 2017. Prices correct at time of going to press: October 2017.

HEAVY DUTY WORKBENCHES

- Can take up to 1000kg (uniformly distributed load)
- Choice of worktops including galvanised steel, stainless steel, wood and solid slip black vinyl.
- All heavy duty workbenches include as standard a single cupboard, bottom shelf, vice plate and a rear Upstand.
- Choice of four standard lengths, each of which is available in three depths.
- Fully welded and ready to use.
- Worktops: Galvanised Steel, Stainless Steel, Wood Worktop & Black Vinyl



CALL FOR A QUOTE
STATE THE SIZE AND THE WORKTOP REQUIRED

FROM ONLY **£305.00**

MOBILE WORKBENCHES

- Mobile workbenches take up to 1000kg on legs and 360kg on castors.
- Stands on four legs when in use and wheels when on the move.
- Simple lever action pushed the under-carriage and take the weight off the legs onto the castors.
- Two versions available – one with a standard cupboard and one with a five drawer unit and matching cupboard.
- All mobile workbenches include as standard a single cupboard, bottom shelf, lowering undercarriage and vice plate.
- Worktops: Galvanised Steel, Stainless Steel, Wood Worktop & Black Vinyl



CALL FOR A QUOTE
STATE THE SIZE AND THE WORKTOP REQUIRED

FROM ONLY **£305.00**

MEDIUM DUTY WORKBENCHES

Medium duty workbenches or assembly workbenches (as they are also known) come fully welded (not flat pack) and ready to use. They are made from 1.5 thick box section and come with all-metal levelling feet.

These workbenches provide an ideal platform for working on small components. There are a number of sizes available and choice of worktops, which include – Grey Laminate, ESD (Antistatic), MDF, Steel, Solid Slip Vinyl. The uniformly distributed load (UDL) is up to 500kg. The standard height is 840mm, but this can be changed at no extra cost.



CALL FOR A QUOTE
STATE THE SIZE AND THE WORKTOP REQUIRED

FROM ONLY **£200.00**

SUPER HEAVY DUTY WORKBENCHES

These workbenches are the heaviest load capacity commonly available. Super heavy duty workbenches come fully welded (not flat pack) and ready to use. They are constructed from steel angle with braced 2mm galvanised steel top over 45mm solid wood. The uniformly distributed load (UDL) is up to 1500kg for each workbench. The standard height is 840mm, but this can be changed at no extra cost.

- Fully welded and ready to use.
- As standard this range includes a single cupboard (600mm x 600mm x depth of workbench), galvanised bottom shelf, rear lip and vice plate (welded under front right hand corner) included in the price.



CALL FOR A QUOTE
STATE THE SIZE AND THE WORKTOP REQUIRED

FROM ONLY **£370.00**

*Finance example typically based on a 5 year lease purchase agreement. Finance subject to status, full terms and conditions available on request. Other finance options available. All prices exclude VAT at 20%. Price, availability and specification may change without prior notice. Warranty subject to manufacturers terms and conditions of use. Errors and omissions excluded. Offers valid until 31st December 2017. Prices correct at time of going to press: October 2017.

Battery Support

NO HASSLE WARRANTY

BEST PRICE PROMISE

GYSFLASH 102:12 HF

597 77 6050

NEW

- Specifically designed to be fitted on a wall or on a vehicle lift
- Provides instantaneous current of up to 100A support the vehicle during key on/off diagnostic work
- Adjustable voltage range 12-14.8V
- Charges ALL Battery Types
- 9 step charging curve ensures maximum battery performance and longevity
- Protection of the vehicle's on-board electronics

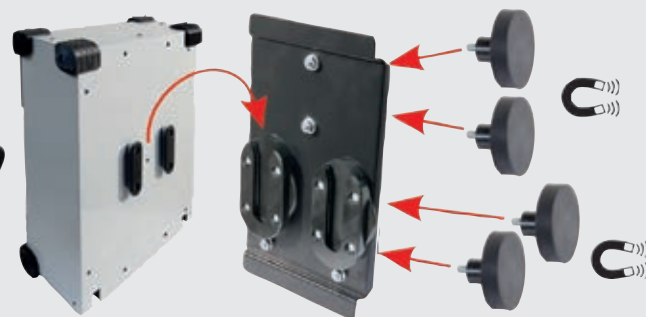

**WALL/LIFT MOUNTED
ADVANCED BATTERY
SUPPORT UNIT &
CHARGER**

ONLY **£699.00**

WITH MAGNETIC FIXING KIT – NO DRILLING REQUIRED

GYSFLASH 100:12HF

- Provides instantaneous current up to 100A to support the vehicle during key/on engine off diagnostic work
- Adjustable voltage from 12-14.8V (can support BMW)
- Advanced charger for AGM/GEL/Lead acid batteries
- Made in France

**ADVANCED
BATTERY SUPPORT
UNIT/BATTERY
CHARGER**



UNIT ONLY
355 77 8370

ONLY **£649.00**

UNIT WITH CUSTOM TROLLEY
355 77 6510

ONLY **£799.00**

*Finance example typically based on a 5 year lease purchase agreement. Finance subject to status, full terms and conditions available on request. Other finance options available. All prices exclude VAT at 20%. Price, availability and specification may change without prior notice. Warranty subject to manufacturers terms and conditions of use. Errors and omissions excluded. Offers valid until 31st December 2017. Prices correct at time of going to press: October 2017.

0845 603 3636
OVER 200 BRANCHES NATIONWIDE

POWERVAMP MR26

592 77 2250

High powered 12V Starter Pack for frequent, everyday professional use. Suitable for starting all sizes petrol engines including 4x4. All 12V Diesel 1.8~3.5 depending on vehicle type

- Anti-surge protection ensures against overloading sensitive electronics
- Internal 3 stage 2.3amp charger
- Detachable 2m heavy duty cable set for easier handling and long-term replacement
- Reverse polarity audio warning
- Shatterproof case for rugged handling



ONLY **£365.00**

BOSCH BAT 490 VERSATILE HIGH-FREQUENCY CHARGER

355 77 2520

Two charging modes for 12V/24V lead-acid batteries i.e: standard program for simple and rapid charging, expert program with flexible charge parameters

- Variable charge current intensity in the expert mode (0-90 A)
- Shorter charging times due to optimized charging process
- Infinitely variable, regulated charging current
- Charging at vehicle electrical system



WEEKLY FROM ONLY **£5.03***
ONLY **£999.00**

GYS STARTIUM 680E

355 77 8430

2 IN 1

ADVANCED STARTER & CHARGER

- Suitable for 12/24V AGM/Gel (Stop/Start) Liquid batteries
- Universal Mode – No need to identify battery type, simply select mode and leave to charge
- Safety – no need to remove battery, voltage protection for vehicle electronics



ONLY **£509.00**

GYS DIAG STARTIUM 60-24

355 77 4890

3 IN 1

ADVANCED STARTER, CHARGER & BATTERY SUPPORT UNIT

- Suitable for 6V/12V/24V batteries
- Charge all battery types: Select the charging curve for the battery type - Liquid, AGM/Gel
- Universal Mode – No need to identify battery type, simply select mode and leave to charge
- Battery Support - 60Amp battery support unit with adjustable voltage (12-15V)
- Safety – no need to remove battery, voltage protection for vehicle electronics



ONLY **£639.00**

*Finance example typically based on a 5 year lease purchase agreement. Finance subject to status, full terms and conditions available on request. Other finance options available. All prices exclude VAT at 20%. Price, availability and specification may change without prior notice. Warranty subject to manufacturers terms and conditions of use. Errors and omissions excluded. Offers valid until 31st December 2017. Prices correct at time of going to press: October 2017.

Transform your equipment output, save energy and money

**HISSING AIR PIPEWORK? UNEVEN PRESSURE IN DIFFERENT PARTS OF THE WORKSHOP?
TOOLS AND EQUIPMENT UNDERPERFORMING?**

PREVOST ALUMINIUM PIPEWORK



Speed and efficiency are the watchwords in automotive repair workshops. That is why it is absolutely necessary to have air tools and equipment working at peak capability so that technicians can make best use of the time they spend working on vehicles.

Workshop Solutions offers a free re-design of your workshop compressed air distribution system that will ensure the air arrives at the technician's workstations with a minimal loss of pressure, and in the best condition to power the tools and equipment.



Using Prevest aluminium pipework, we can install a compressed air system that is matched to your current and future requirements and which keep you working at maximum efficiency whilst also saving you money from wasted energy.

- Energy Efficient – aluminium provides perfectly smooth internal pipe surface – that means an optimised flow rate, with a clean and good-quality air supply.
- Guaranteed for 10 years – aluminium pipework is compact, lightweight and resistant to corrosion – this means it is easy to install and maintain
- No leaks – Prevest pipe fittings are engineered to ensure perfectly leak-tightness even under the harshest conditions



GIVE US A CALL



Our Workshop Equipment Specialists, working with Prevest, can carry out a survey of an existing workshop air pipework system, and using real-life data, can work out exactly how much energy (and therefore cash) is being hissed away.

We can design and install a Prevest aluminium pipework system which will lower workshop energy bills, provide equalised pressure throughout, and which will not corrode and develop leaks over time.

- A general diagram of your compressed air ring main complete with downpipes is drawn so that you can see the location and layout of your system in your building.
- A detailed drawing identifying the connections and purposes of each downpipe is then generated.
- A complete quote listing each item, the corresponding quantities, and the price of the proposed ringmain is provided for your consideration.



*Finance example typically based on a 5 year lease purchase agreement. Finance subject to status, full terms and conditions available on request. Other finance options available. All prices exclude VAT at 20%. Price, availability and specification may change without prior notice. Warranty subject to manufacturers terms and conditions of use. Errors and omissions excluded. Offers valid until 31st December 2017. Prices correct at time of going to press: October 2017.

EXPTEL 30 - POINT OF USE LIQUID WATER, OIL & PARTICULATE COMPRESSED AIR FILTER

Exceptional compressed air quality guaranteed

Expel will dramatically improve compressed air systems throughout the industry. The unique patented design allows it to efficiently remove 99.9999% of liquid, oil, water and removes other contaminants down to 1 micron when installed at point of use.

PRODUCT OVERVIEW

- 30 cfm max rated flow rate
- 15 bar(g) - 217 psi(g) maximum pressure
- 2 year manufacturer's warranty
- 1/2" & 3/4" BSPT / NPT inlet / outlet connections
- Removes 99.9999% all liquid water, oils, and filters particulates down to 1 micron
- Pressure indicator as standard
- 1/2" BSPT / NPT male drain port

FEATURES

- Tested to ISO 12500 – part 3 & 4 standard
- Worlds first cleanable, reusable compressed air filter
- No increase in pressure drop caused by contaminated filters
- No power source required
- Significantly reduced life cycle costs
- Easy to install & maintain
- Fully dismantlable
- No decrease in performance over lifetime of well maintained filter



EXPTEL FILTER

WITH 1/2" INLET/OUTLET CONNECTION
595 777 980

ONLY **£233.00**

EXPTEL FILTER

WITH 3/4" INLET/OUTLET CONNECTION
595 777 990

ONLY **£233.00**

DRYERS

Humidity is a component of atmospheric air. This means it can be found in the compressed air distribution systems, and the equipment that use the compressed air, in the form of condensate and/or vapour.

Refrigeration dryers remove condensate and vapour so that the compressed air reaches the equipment dry – which is the best condition for powering the equipment efficiently and for a long time..

- Longer life span of your equipment and distribution network due to less wear
- Greater productivity and lower maintenance costs thanks to less breakdowns
- Higher final air quality
- Increased reliability of your final tools/equipment



DRY 25
HANDLES UP TO 12.4CFM
591 77 3300

ONLY **£811.00**

DRY 45
HANDLES UP TO 21.2CFM
591 77 4030

ONLY **£956.00**

DRY 60
HANDLES UP TO 21.2CFM
595 77 7600

WEEKLY FROM ONLY **£5.43⁺**
ONLY **£1,077.00**

*Finance example typically based on a 5 year lease purchase agreement. Finance subject to status, full terms and conditions available on request. Other finance options available. All prices exclude VAT at 20%. Price, availability and specification may change without prior notice. Warranty subject to manufacturers terms and conditions of use. Errors and omissions excluded. Offers valid until 31st December 2017. Prices correct at time of going to press: October 2017.

SELECTING THE RIGHT COMPRESSOR

When selecting the right air compressor, the tank size is important. A small tank will overwork the motor. It is equally if not more important to select an air compressor that provides enough cubic feet per minute (cfm) of airflow. CFM is going to determine how many tools you can run, and whether each tool will function at its best.

| TOOL/EQUIPMENT | CFM | BAR |
|-------------------------|---------|---------|
| 3/8" Impact Wrench | 2 – 3 | 6 |
| 1/2" Impact Wrench | 4 – 6 | 6 |
| 3/4" Impact Wrench | 9 | 6 |
| 1" Impact Wrench | 14 | 6 |
| 3/8" Ratchet | 2 – 5 | 6 |
| 1/2" Ratchet | 5 | 6 |
| 3/8" Drill | 12 | 6 |
| DA Sander (Top Quality) | 10 | 6 |
| DA Sander (econ. model) | 20 | 6 |
| 7" Sander/Polisher | 25 | 6 |
| Zip/Impact Cutter | 4 – 5 | 6 |
| Cutters Shears | 4 – 8 | 6 |
| 4" Angle Grinder | 18 – 25 | 6 |
| 7" Angle Grinder | 25 – 35 | 6 |
| Tyre Inflator | 2 – 4 | 10 – 16 |
| Tyre Changer (Manual) | 4 | 10 |
| Tyre Changer (Auto) | 6 | 10 |
| Sand Blast Cabinet | 10 – 50 | 3.5 – 7 |
| Sand Blast Hand Gun | 8 – 12 | 7 |

| TOOL/EQUIPMENT | CFM | BAR |
|--------------------------|---------|-----------|
| Spray Gun – Airbrush | 0.25 | 2 |
| Spray Gun – Miniature | 4 – 7 | 1.5 – 3.5 |
| Spray Gun – Low Pressure | 1.5 – 4 | 1.5 – 3 |
| Spray Gun – Standard | 7.14 | 3.5 – 4 |
| Spray Gun – HVLP | 14 – 20 | 5 – 6 |
| HA/GEO/9000 series LVLP | 7 – 9.5 | 2 – 2.5 |
| Air Fed Mask | 5 – 6 | 1.5 – 3 |
| Oil Pump | 1.5 | 7 – 10.5 |
| Grease Pump | 4.5 | 7 – 10.5 |
| Air Water Wash | 10 | 10.5 |
| Car Wash | 1.5 – 5 | 5 – 7 |
| Blow Gun (safety nozzle) | 3 | 7 |
| Spark Plug Cleaner | 3 | 7 |
| Underseal Gun | 4 | 7 |
| Rivet Gun | 1.5 – 3 | 50 – 6 |
| 2 Ton Air/Hydraulic Lift | 5 – 8 | 9 – 10.5 |
| Brake Tester | 3 – 7 | 5 – 7 |
| Plasma Cutter | 6 – 8 | 4 – 7 |

COMPRESSORS AND AIR TREATMENT

Compressed air is all about the compressor, right?

Wrong. Of course, a quality compressor is important if you're doing anything with air tools but there are other factors you need to consider if you want an efficient system that won't let you down, particularly in challenging environments like spray booths, where the quality of air you're using is critical to the quality of the job you produce.

Air Pipework

Next, we come to the pipework, that essential conduit between compressor and tool. Any amount of 'hissing' means you've got at least one leak and that's the sound of your hard-earned cash escaping from your pocket in the form of wasted energy. Your compressor has to work harder to produce the air you need, leading to a shorter compressor lifespan and poorer performing equipment.

If your pipework design is not optimised, you're losing efficiency (and money) over the length of the system. It's not just leaks in old galvanised pipework you should worry about, the internal bore may well be severely compromised through a lifetime build-up of deposits and corrosion, which will only compound the loss of efficiency of your compressor and air tools.

Our Workshop Equipment Specialists can help maximise your profits by calculating the savings you'll make by installing a new

plastic/aluminium air ring main, designed to support your current and future needs. It won't corrode and it will provide greater flexibility and performance than your current galvanised option, delivering a consistent airflow with no efficiency loss and, a minimum maintenance requirement.

Drying and Filtration

We live in a climate with an average 90% humidity. Compressors don't introduce water into your compressed air system, it's always there; so, it's important to remove it to maximise performance and provide a truly efficient system.

Even the toughest compressed air tools work best on dry air that is free of foreign particles but it's absolutely essential for certain environments like spray booths where surface finish and personal protection (breathing air) is critical.

Your compressed air system will provide maximum performance and extended tool life when drying and filtration are incorporated because water vapour and foreign particles in the air feed will always reduce the efficiency of the system and lifespan of your tools.

Talk to our WESs for a full consultation on your compressed air system and on how you can save on energy and equipment replacement costs whilst getting the best efficiency and all the power from your air tools.

*Finance example typically based on a 5 year lease purchase agreement. Finance subject to status, full terms and conditions available on request. Other finance options available. All prices exclude VAT at 20%. Price, availability and specification may change without prior notice. Warranty subject to manufacturers terms and conditions of use. Errors and omissions excluded. Offers valid until 31st December 2017. Prices correct at time of going to press: October 2017.

ALL SCREW COMPRESSORS COME WITH 2 YEAR WARRANTY

WILKINSON STAR SILVER SCREW COMPRESSORS



- For applications where there is a constantly high demand for air power
- Powerful, efficient heavy duty belt drive motors
- Low noise levels

SILVER 10 300L
572 77 1870

WITH FREE 160A MIG WELDER

3 phase FAD 30cfm 300L 10HP WARRANTY 2yr

WEEKLY FROM ONLY **£18.40⁺**
ONLY £3,651.70

SILVER 15 300L
572 77 1890

3 phase FAD 51cfm 300L 15HP WARRANTY 2yr

WEEKLY FROM ONLY **£24.01⁺**
ONLY £4,764.70

WILKINSON STAR SILVER D SCREW COMPRESSORS



- Refrigerated dryer option for clean, dry air production.
- Simple-to-use control units
- Enabling manage, monitor and optimise the machine's operation

SILVER D 10 300L
572 77 2080

3 phase FAD 30cfm 300L 10HP WARRANTY 2yr

WEEKLY FROM ONLY **£23.66⁺**
ONLY £4,695.00

SILVER D 15 300L
572 77 1910

3 phase FAD 51cfm 300L 15HP WARRANTY 2yr

WEEKLY FROM ONLY **£28.29⁺**
ONLY £5,613.00

SILVER D 20 300L
572 77 1930

3 phase FAD 67cfm 300L 20HP WARRANTY 2yr

WEEKLY FROM ONLY **£30.69⁺**
ONLY £6,089.70

ABAC SPINN COMPRESSOR!

SPINN 2.2KW
572 77 0270

Typical use: Spray gun, impact wrenches, tyre machines.
Single phase, low noise.



1 phase FAD 8.5cfm 200L 3HP WARRANTY 2yr

WEEKLY FROM ONLY **£13.46⁺**
ONLY £2,669.65

SPINN 4KW
572 77 0230

Typical use: Spray gun, impact wrenches, tyre machines.
Low noise, good quality air

3 phase FAD 16.6cfm 200L 5.5HP WARRANTY 2yr

WEEKLY FROM ONLY **£14.26⁺**
ONLY £2,830.15

Typical use: Spray guns, impact wrenches, tyre machines, sanders, air fed masks. Low noise, good quality air

SPINN 5.5KW
572 77 0710

3 phase FAD 21.2cfm 270L 7.5HP WARRANTY 2yr

WEEKLY FROM ONLY **£15.61⁺**
ONLY £3,097.65

SPINN E 5.5KW With Dryer
572 77 0490

3 phase FAD 21.2cfm 270L 7.5HP WARRANTY 2yr

WEEKLY FROM ONLY **£18.87⁺**
ONLY £3,745.00

ABAC GENESIS COMPRESSORS
With Dryer And Filtration Build In

GENESIS 7.5KW
572 77 0440

Typical use: Spray guns, impact wrenches, tyre machines, sanders, air fed masks.
Low noise, high output, good quality dry air, small footprint.



3 phase FAD 40.7cfm 270L 10HP WARRANTY 2yr

WEEKLY FROM ONLY **£24.78⁺**
ONLY £4,916.65

Typical use: Tyre Inflator, Blow Gun, Spray Gun, Impact/ Ratchet wrenches. Low noise, higher output for larger spray shops.

GENESIS 11KW
572 77 0180

3 phase FAD 58.8cfm 270L 15HP WARRANTY 2yr

WEEKLY FROM ONLY **£25.86⁺**
ONLY £5,130.65

GENESIS 15KW
572 77 0380

3 phase FAD 78.3cfm 270L 20HP WARRANTY 2yr

WEEKLY FROM ONLY **£26.94⁺**
ONLY £5,344.65

*Must be commissioned and serviced by an authorised distributor

*Finance example typically based on a 5 year lease purchase agreement. Finance subject to status, full terms and conditions available on request. Other finance options available. All prices exclude VAT at 20%. Price, availability and specification may change without prior notice. Warranty subject to manufacturers terms and conditions of use. Errors and omissions excluded. Offers valid until 31st December 2017. Prices correct at time of going to press: October 2017.

ABAC PRO PISTON COMPRESSORS

Ideal for a small workshop where only single phase is available.

Belt driven, resulting in a quieter and more efficient compressor

Typically used with Tyre Inflator, Blow Gun, Spray Gun, Impact/ Ratchet wrenches



PRO A39B 150 FM3

572 77 0580



ONLY **£508.25**

PRO A39B 200 FM3

572 77 0560



ONLY **£561.75**

PRO B4900 200 FT4

572 77 0670

Perfect for a small workshop with three phase

Typically Used with Tyre Inflator, Blow Gun, Spray Gun, Impact/ Ratchet wrenches, low consumption shot blast cabinet



ONLY **£690.15**

PRO B5900B 200 FT5.5

572 77 0680

Perfect for a medium workshop with three phase



ONLY **£810.00**

PRO A39 270 FM3 TANDEM

572 77 0690

Ideal for a small workshop where only single phase is available. Largest single phase piston compressor available.

Belt driven, resulting in a quieter and more efficient compressor.



WEEKLY FROM ONLY **£8.31⁺**
ONLY **£1,649.00**

WILKINSON STAR WORKHORSE COMPRESSORS

Typically used with: Impact wrench, Ratchet wrench, Air chisel, underseal gun, tyre inflator

Ideal for a small workshop where only single phase is available



WORKHORSE WR3HP - 150SEC

572 77 1630



ONLY **£434.60**

WORKHORSE WR3HP - 200SEC

572 77 1670



ONLY **£487.60**

WORKHORSE WR4HP - 200SEC

572 77 1680



ONLY **£793.94**

Typically used with: Impact wrench, Tyre changer, Small DA Sander, brake tester

For the busier 2/3 man mechanical workshop where three phase is available

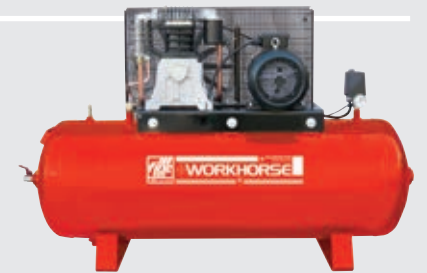

WORKHORSE 5.5HP - 200SEC

572 77 1690



ONLY **£858.60**

WORKHORSE WR5.5HP - 270SEC

572 77 1710



ONLY **£879.80**

WORKHORSE WR7.5HP - 270SEC

572 77 1740



WEEKLY FROM ONLY **£5.32⁺**
ONLY **£1,054.00**

WORKHORSE WR10HP - 200SEC

572 77 1750

Typically used with: Spray gun, DA Sander, Lift, 1" Impact wrench
For a commercial workshop / small bodyshop
Accident / Car panel Repair.



WEEKLY FROM ONLY **£7.72⁺**
ONLY **£1,531.70**

*Finance example typically based on a 5 year lease purchase agreement. Finance subject to status, full terms and conditions available on request. Other finance options available. All prices exclude VAT at 20%. Price, availability and specification may change without prior notice. Warranty subject to manufacturers terms and conditions of use. Errors and omissions excluded. Offers valid until 31st December 2017. Prices correct at time of going to press: October 2017.

Wheel Service – Low Volume

NO HASSLE WARRANTY **BEST PRICE PROMISE**

WERTHER TITANIUM COMPLETE TYRE PACKAGE 583 01 0030

- Fully automatic tyre changer plus wheel balancer
- Single phase supply
- Including assistant arm
- From 11" to 24" wheels



WEEKLY FROM ONLY **£13.08***
ONLY £2,595.00

HOFMANN MEGAPLAN ECOMOUNT 22 PLUS TYRE CHANGER AND JUNIOR LITE BALANCER PACKAGE 583 01 0130

- 10" to 24" Clamping (22" external)
- 13" rim width capability
- Fully-Automatic Operation
- Includes 'megafit 2' assist arm



WEEKLY FROM ONLY **£13.68***
FROM ONLY £2,715.00

BRADBURY WC5301 TYRE CHANGER AND WC5521i WHEEL BALANCER 583 77 0100

INCLUDES 1 YEAR FREE MAINTENANCE CONTRACT*

- Fully automatic tyre changer with assist arm and wheel balancer
- Single phase supply
- From 12"-23" wheels
- 14"-26" clamping
- Suitable for low profile & run flat tyres

FREE STARTER PACK WORTH £80



WEEKLY FROM ONLY **£16.38***
FROM ONLY £3,250.00

*Includes 1 service at 6 months, and 1 service at 12 months

PROWAY ELITE 220 TYRE CHANGER AND ELITE 110 WHEEL BALANCER FROM HOFMANN MEGAPLAN 583 77 0930

- Reliable and efficient design.
- Extensively tested prior to delivery.
- Operator training included.
- The ideal entry-level option.



WEEKLY FROM ONLY **£13.58***
ONLY £2,695.00

*Finance example typically based on a 5 year lease purchase agreement. Finance subject to status, full terms and conditions available on request. Other finance options available. All prices exclude VAT at 20%. Price, availability and specification may change without prior notice. Warranty subject to manufacturers terms and conditions of use. Errors and omissions excluded. Offers valid until 31st December 2017. Prices correct at time of going to press: October 2017.



PRICES INCLUDE DELIVERY & INSTALLATION

SAVE £200 WHEN YOU BUY THE TCE4430 AND WBE4200 OR WBE4120

BOSCH TCE 4430-24 TYRE CHANGER

4 YEARS WARRANTY

The tilt back tyre changer TCE 4430-24 is equipped with a 24" (external clamping) turntable.

The tyre changer offers pneumatic positioning of the mounting head, and an adjustable bead breaker. The extreme rigidity of the structure and the use of the G-frame concept make this machine the market benchmark for robust and solid performance. The helper system and the wheel lift makes the work even easier.

- Comes with a 4 year warranty (2 years parts and labour 2 years parts only)



3 PHASE 583 77 0490
1 PHASE 583 77 0970



WEEKLY FROM ONLY **£19.13⁺**
ONLY **£3,795.00**

BOSCH WBE 4200 WHEEL BALANCER

584 04 0370

Semi-automatic wheel balancer offers garages and workshops a simple, high precision and easy-to-use value machine. Clear digital read-outs for passenger cars, light commercial vehicles and motorcycles, with a new ergonomic design allowing for better access to the inside of the wheel and an improved working position, creating more comfort for the user.

- Comes with 2 years warranty as standard with the option of additional service/calibration plans



WEEKLY FROM ONLY **£10.05⁺**
ONLY **£1,995.00**

WBE4120D/DT COMPACT AND RELIABLE WHEEL BALANCER

The WBE 4120 series is an electronic wheel balancer designed for low to medium volume workshops. It is extremely versatile thanks to the compact design making it suitable for the narrowest environments, while still capable of working with all types of car, motorcycle and light commercial vehicle wheels. Supplied with a TFT monitor, Easyfit internal electronic measuring arm and a complete software package including all static and dynamic balancing programmes.

Thanks to the new wheel cover shape and the new weight holders, WBE4120D is the perfect equipment in the workshop environment.

- Small footprint – suitable for the narrowest environment
- Max. wheel weight 65kg
- Optional, external electronic measuring arm for rim width
- Comes with a manufacturer's 2 year warranty



WBE4120D
584 77 0620



WEEKLY FROM ONLY **£9.05⁺**
ONLY **£1,795.00**

WBE4120DT
584 77 0630



WEEKLY FROM ONLY **£11.06⁺**
ONLY **£2,195.00**

*Finance example typically based on a 5 year lease purchase agreement. Finance subject to status, full terms and conditions available on request. Other finance options available. All prices exclude VAT at 20%. Price, availability and specification may change without prior notice. Warranty subject to manufacturers terms and conditions of use. Errors and omissions excluded. Offers valid until 31st December 2017. Prices correct at time of going to press: October 2017.

Wheel Service – Medium/High Vol.

NO HASSLE WARRANTY

BEST PRICE PROMISE

PRICES INCLUDE DELIVERY & INSTALLATION

JOHN BEAN B100 AND T5305

Tyre and wheel package including tilt back tyre changer for all conventional tyres on the market, including helper arm and 10"-20" clamping range, and digital wheel balancer with 2D SAPE (semi-automatic parameter entry) for measurement of wheel offset and wheel diameter in one process.

B100 FEATURES

- Built using the VPI measuring system for high accuracy and repeatability
- Automatic start of measurement when hood is closed and brake applied at end of spin cycle
- Intuitive control panel and display
- Split weight mode – hide weights behind wheel spokes for more appealing cosmetic finish
- Tyre matching mode – optimise tyre to rim so using less weights

T5305 FEATURES

- Pneumatic tilting column
- Table has two cylinders for improved gripping of the rim
- Side bead breaking with adjustable inclination
- Assist arm:
 - Drop centre pressing tool
 - Rim centre pushing tool
- Steel head with plastic inserts



*Some run-flat tyres may require additional adaptors

B100

584 05 0150



WEEKLY FROM ONLY **£10.56⁺**
ONLY £2,095.00

T5305

583 01 0140



WEEKLY FROM ONLY **£15.11⁺**
ONLY £2,999.00

B100 + T5305 PACKAGE

583 01 0170

WEEKLY FROM ONLY **£20.13⁺**
ONLY £3,995.00

JOHN BEAN B340L AND T5545

Tyre and wheel package including twin-speed tyre changer for all conventional tyres on the market, including helper arm and 10"-24" clamping range, and touchscreen wheel balancer with 2D SAPE (semi-automatic parameter entry) and Smart Sonar input for automatic measurement of wheel offset, wheel diameter and wheel width, plus a pinpoint laser indicator for weight placement.

B340L FEATURES

- 10in touchscreen LCD display
- EasyWeight pinpoint laser indicator for adhesive weight placement
- EasyALU to automatically recognise the weight mode – ALU-P or steel
- QuickBal – reduced measurement 4.5 seconds (15" rim)

T5545 FEATURES

- Double-acting bead breaker cylinder
- Four self-centring turntable jaws
- Quick-inflating valve
- Outer clamping range up to 24 inches
- Pneumatic tilt back post, pneumatically locked in working position
- e-designed assist arm suited for handling run-flat tyre systems (additional optional adaptors required for PAX and CSR)



B340L

584 77 0640



WEEKLY FROM ONLY **£19.56**
ONLY £3,880.00

T5545

583 01 0160



WEEKLY FROM ONLY **£22.73⁺**
ONLY £4,510.00

B340L + T5545 PACKAGE

583 77 1010

WEEKLY FROM ONLY **£42.31⁺**
ONLY £8,395.00

*Finance example typically based on a 5 year lease purchase agreement. Finance subject to status, full terms and conditions available on request. Other finance options available. All prices exclude VAT at 20%. Price, availability and specification may change without prior notice. Warranty subject to manufacturers terms and conditions of use. Errors and omissions excluded. Offers valid until 31st December 2017. Prices correct at time of going to press: October 2017.



Wheel Service – High Volume

NO HASSLE
WARRANTY

BEST PRICE
PROMISE

PRICES INCLUDE DELIVERY & INSTALLATION

HOFMANN MEGAPLAN MEGAMOUNT 503XL

583 77 0410

Fully Automatic and boasting a 'top end' specification, the Megamount 503XL is capable in any environment. The patented, adjustable turntable enables alloy rims up to 26" in diameter to be clamped from the outside, and the tall column and wide bead breaker opening ensures suitability for extra-wide rims up to 15". A bead breaker 'stroke limiter' for shallow-welled BMW rims and quick-release, interchangeable demount head system, with standard/run-flat, plastic and 'raised spoke' heads, completes the luxury specification.

- 10" to 28" Clamping (26" external)
- 15" Rim Width Capability
- Quick-Release Demount Head System for Standard/RFT, Plastic and 'Raised Spoke'
- Includes 'Megafit 2XL' assist arm
- BMW/Run-Flat 'Stroke Limiter' as standard
- Double-acting bead breaker
- Fully-Automatic Operation



WEEKLY
FROM ONLY **£20.13⁺**
ONLY **£3,995.00**

**UPGRADE TO MEGAMOUNT 503 EVO
WITH LEVERLESS OPERATION
FOR ONLY £ 1,299 +VAT**



HOFMANN MEGAPLAN MEGASPIN 200V

583 05 0510

The Megaspin 200V has to offer one of the best price/performance ratios of any wheel balancer on today's market. Fully-automatic (3D) data input is achieved using the inner measuring/weight placement arm and Hofmann Megaplan's revolutionary IWA (Intelligent Width Assessment) software.

Values are displayed live on the full colour TFT display. The displayed graphics will guide the operator to the designated weight placement position, as well as delivering what is probably the simplest, fastest method of 'split weight' (hiding the weights behind the spokes) ever.

- 3D Fully-Automatic Data Input via IWA
- Colour TFT Display
- Can handle rims up to 30" diameter
- Simple, speedy operation
- 4 years PCB Warranty



WEEKLY
FROM ONLY **£12.57⁺**
ONLY **£2,495.00**



*Finance example typically based on a 5 year lease purchase agreement. Finance subject to status, full terms and conditions available on request. Other finance options available. All prices exclude VAT at 20%. Price, availability and specification may change without prior notice. Warranty subject to manufacturers terms and conditions of use. Errors and omissions excluded. Offers valid until 31st December 2017. Prices correct at time of going to press: October 2017.

0845 603 3636
OVER 200 BRANCHES NATIONWIDE

Wheel Service – High Volume

NO HASSLE WARRANTY

BEST PRICE PROMISE

PRICES INCLUDE DELIVERY & INSTALLATION

HOFMANN MEGAPLAN MEGAMOUNT EASY

583 77 0420

The Megamount Easy represents an alternative style of tyre changer, where manual effort is reduced to a minimum, and the emphasis is on larger rims fitted with low profile tyres.

An integral wheel lifter makes light work of the heaviest assemblies, and the centre post clamping with the simple and speedy 'Smart Lock' ensures there is no contact with the outer edge of the rim. The famous Hofmann Megaplan 'Evolution' leverless system is enhanced with the new 'Lever No Lever' design, which enables the operator to switch between leverless operation and traditional lever & demount head at the flick of a switch.

Unlike many other 'Next Generation' tyre changers on the market, the EASY was designed with one major focus; simplicity. In every element of the tyre fitting and removal process, the directive has been to ensure that operation remains simple, minimising the number of controls and functions – Easy by name, and Easy by nature.

- 10" to 30" Clamping Capability via Centre Post method with 'Smart Lock'
- Lever No Lever system enables dual leverless or traditional levered fitting as preferred
- Integral wheel lifter
- Dynamic bead breaking system via roller
- 'Next generation' tyre changer design



WEEKLY FROM ONLY **£29.21⁺**
ONLY **£5,795.00**

HOFMANN MEGAPLAN MEGASPIN 420

584 77 0370

The most advanced technology the industry has seen in a wheel balancer. The combination of revolutionary new technology, incredible simplicity, and typical Hofmann Megaplan reliability makes this, in our opinion, the best value wheel balancer on the market today.

Boasting 'No Checkspin' technology and 6 o'clock weight positioning, the Megaspin 420 only requires the operator to select the weight position(s) and lower the hood – it's that simple! Two laser points guide the operator to the chosen weight position, and the rim locks into position at each inner and outer 6 o'clock placement position.

There is no possibility for error, no chance of the machine throwing up an extra 5 or 10gms, and absolutely No Checkspin Required!

- Worlds' first balancer with 'No Checkspin' technology
- Easier 6 o'clock weight position
- Super Automatic Data Input via sonar (touch-free)
- Laser Guided weight placement
- Handles rims up to 30" diameter
- The simplest, fastest wheel balancer ever produced



WEEKLY FROM ONLY **£17.11⁺**
ONLY **£3,395.00**

*Finance example typically based on a 5 year lease purchase agreement. Finance subject to status, full terms and conditions available on request. Other finance options available. All prices exclude VAT at 20%. Price, availability and specification may change without prior notice. Warranty subject to manufacturers terms and conditions of use. Errors and omissions excluded. Offers valid until 31st December 2017. Prices correct at time of going to press: October 2017.



Wheel Service – High Volume

NO HASSLE WARRANTY

BEST PRICE PROMISE

PRICES INCLUDE DELIVERY & INSTALLATION

BOSCH TCE4470 S122

Bosch TCE 4470 tilting back tyre changer provides a range of innovative features designed for maximum speed, performance and durability – even for the toughest UHP or RFT passenger car and light commercial tyres. With the addition of a special accessory kit, this machines can also handle motorcycle tyres.

The new design helper arm is especially designed for tyre specialists and high-volume workshops. A wheel lift, which allows you to work always in an ergonomic position, is available as an optional extra.

- Big space for wheel seating – outside clamping
- Suitable for fast-fits and high volume workshops
- Big space for wheel seating – outside clamping 28 inch and wheel width up to 15 inch without any special pre-adjustment
- Pneumatic positioning mounting head
- Revolutionary Ergo Control bead breaker makes the operation safe, quick, precise and comfortable
- Fitted with TCE 330, helper arm with two independent pressure points
- TSL 230 lift as accessory with integrated roller board – optional extra
- Manufactured in Europe
- Available in 1ph and 3ph
- Comes with a 4 year warranty (2 years parts and labour 2 years parts only)

1PH

583 77 0980



WEEKLY FROM ONLY **£30.21⁺**
ONLY £5,995.00

3PH

583 77 0990



WEEKLY FROM ONLY **£30.21⁺**
ONLY £5,995.00

4 YEARS WARRANTY



BOSCH WBE4400

584 04 0380

Wheel balancer developed for precise measurement and easy handling. The WBE4400 has a new ergonomic design developed for easy and precise wheel balancing for cars, motorcycles and vans. The unit offers a new feature to detect the positioning of weights and various static and dynamic balancing options. The wheel balancing machine will accommodate wheels with a diameter up to 1,200 mm and are equipped with an easy-to-read 19" TFT monitor.

- Space-saving wheel guard design
- Weight positioning system with automatic diameter and clearance measurement
- Optional external arm for automatic rim width measurement
- Large, deep weight compartments



WEEKLY FROM ONLY **£14.09⁺**
ONLY £2,795.00

SAVE £275
WHEN YOU BUY THE TCE4470 + WBE4400 TOGETHER!



*Finance example typically based on a 5 year lease purchase agreement. Finance subject to status, full terms and conditions available on request. Other finance options available. All prices exclude VAT at 20%. Price, availability and specification may change without prior notice. Warranty subject to manufacturers terms and conditions of use. Errors and omissions excluded. Offers valid until 31st December 2017. Prices correct at time of going to press: October 2017.

Mid-Rise Scissor Lifts

**NO HASSLE
WARRANTY**

**BEST PRICE
PROMISE**

JOHN BEAN SSL 33 ELECTRO-HYDRAULIC MID-RISE LIFT 581 05 0010

Portable lift designed to lift cars and light commercial vehicles.

- Small size and portability make this a great investment for any busy garage
- Single phase operation
- 1m lifting height
- Pneumatic safety lock
- Includes mobile kit
- Run on ramps double as lift extensions



WEEKLY FROM ONLY **£14.81[†]**
ONLY **£2,939.00**

CRYPTON CML3000 3T MIDRISE SCISSOR LIFT 581 77 0320

Safely lifts most vehicles including SUV's up to 3tonnes.

- Portable lift to move around your workshop quickly and easily
- 1m lifting height for wheel and tyre refits, brakes and suspension inspection and under body, paint and bodywork
- Arrives pre-assembled for fast and easy set-up. Simply unpack, fill with hydraulic oil and plug in
- Two cylinders and independent hydraulic systems protects the lift from sagging and ensures mechanical synchronisation
- No compressed air required
- Galvanised anti-skid platforms with adjustable length
- Suitable for indoor and outdoor use (additional working space)
- Fast lifting and lowering times
- 3 year warranty as standard



WEEKLY FROM ONLY **£14.41[†]**
ONLY **£2,859.00**

**3 YEARS
WARRANTY**

LIFTMASTER SPRINTER 3T MID-RISE SCISSOR LIFT 581 77 0031

With almost one meter lifting height, the Sprinter covers 90% of all activities in the workshop. Thanks to the mobile kit (supplied as standard), the lift is easily moveable around the workshop.

By picking up the vehicle at the sillboards, the Sprinter safely picks up most vehicles (including SUV vehicles), up to 3 Tons. Super ductile polymer pads (supplied as standard) protect the car's underbody.

Ideal for Wheel and Tyre work, Chassis and Underbody work; Bodypanel and Smart repair; Valeting and Detailing

| | |
|-----------------------------|-----------|
| Capacity (kg) | 3000 |
| Lifting time approx. (sec.) | 11 |
| Lifting height (mm) | 980 |
| Drive over height (mm) | 102 |
| Runway length (mm) | 1400-2010 |
| Runway width (mm) | 450 |
| Motor (kW) | 1,5 |

WEEKLY FROM ONLY **£13.58[†]**
ONLY **£2,695.00**

**PRICE INCLUDES
INSTALLATION**



**2 YEARS
WARRANTY**

- Almost 1 metre lifting height
- Electro-Hydraulic operation
- Single Phase 16amp supply required
- Lifting platforms adjust from 1400-2010mm
- Includes mobile kit
- Made in Germany

*Finance example typically based on a 5 year lease purchase agreement. Finance subject to status, full terms and conditions available on request. Other finance options available. All prices exclude VAT at 20%. Price, availability and specification may change without prior notice. Warranty subject to manufacturers terms and conditions of use. Errors and omissions excluded. Offers valid until 31st December 2017. Prices correct at time of going to press: October 2017.



Choosing The Right 2 Post Lift

NO HASSLE
WARRANTY

BEST PRICE
PROMISE

If you're thinking of introducing additional lift capacity into your workshop but have limited space, then a 2-post option may well be the way to go. There are a number of options for you to consider and you'll find some of the key points throughout the pages of this feature.

The featured lifts are only a selection of the available options so, when you've had a look through this feature, why not let your local Workshop Solutions Specialist help you decide on exactly the right option for you. Just call your local branch and we'll do the rest.



Baseplate or Baseless?

BASEPLATE

A lift with a baseplate has the electrics and cables or chains running across the floor, between the posts. This is commonly known as a Floorplate or H Frame setup.

Pros: Accommodates low workshop ceiling height and may help in overcoming poor floor conditions. No Vehicle height restriction (other than your ceiling height!).

Cons: Intrusive when using a transmission jack and when manoeuvring vehicles over the cross member.

BASELESS

A baseless clearfloor lift requires the cables and hydraulics to pass over the top of the posts.

Pros: No Floor connections so no problems with transmission jacks or manoeuvring vehicles. Easy to keep floor clean.

Cons: High ceilings are required! Not suitable for large/tall vehicle work (Touch top Bar).

Mechanical Screw or Hydraulic Operation?

MECHANICAL SCREW LIFTS

Standard for a lot of older designs – electrically powered.

Pros: A vehicle on the lift does not have to go up before lowering.

Cons: Slower Operation, old fashioned and costly to run.

HYDRAULIC LIFTS

Pros: Generally Faster operation, no Regular nut replacement, simple design, cheaper electrical costs

Cons: Generally, these use 'safety locks' – a vehicle has to raise out of locks before lowering, which can be inconvenient for gearbox or engine work where precise placement is required – there are some exceptions.

Lift Arm Configuration Symmetrical or Asymmetrical?

ASYMMETRIC

Asymmetric lifts have one arm longer than the other on each post

Pros: Allow ease of access - opening the vehicle front doors (60/40 split)

Cons: The lift can only be installed facing one way. The control box can only be mounted to one post. Vehicles can only be driven on in one direction.

SYMMETRIC

Symmetric lifts have arms of the same length

Pros: Vehicles can be driven, or reversed on. Electrics to be fitted to either post.

Cons: May struggle to accommodate some shorter chassis vehicles

Other considerations

LIFT ARM LENGTHS:

Determine the range of chassis lengths the lift can accommodate.

DRIVE-THRU WIDTHS:

Most lifts have a set width between the posts. Some are available in two different width options, offering greater flexibility in lift positioning.

POWER SUPPLY:

Most lifts require three-phase supply as standard, there's usually a premium to pay for single-phase.

COUNTRY OF DESIGN AND COUNTRY OF MANUFACTURE:

Some European or American designed lifts are manufactured in the Far East, others are manufactured in Europe or America.

WARRANTY:

How important is peace of mind? Standard warranties vary between 1, 2, 3 and 5 years.

*Finance example typically based on a 5 year lease purchase agreement. Finance subject to status, full terms and conditions available on request. Other finance options available. All prices exclude VAT at 20%. Price, availability and specification may change without prior notice. Warranty subject to manufacturers terms and conditions of use. Errors and omissions excluded. Offers valid until 31st December 2017. Prices correct at time of going to press: October 2017.

0845 603 3636
OVER 200 BRANCHES NATIONWIDE

Entry Level 2 Post Lift

NO HASSLE WARRANTY

BEST PRICE PROMISE

L4000 M/E 2 POST 4 TON HYDRAULIC LIFT

This value Lift has a lot to offer. Symmetric arms offer wide flexibility to lift most cars and car derived vans in either direction. Electro-magnetic safety locks conveniently release at the push of a button. (A manual lock release version of this lift is also available)

- Hydraulic hoses and balance cables are all fully concealed, providing a clean appearance.
- The double hydraulic cylinders and high strength chain drive provide smooth lifting and lowering.
- Screw height adaptors supplied as standard - 4x4 adaptors available at extra cost.
- An emergency lowering valve can be manually operated to lower the lift safely in the event of a power failure.
- Meanwhile, a flow-control valve prevents the possibility of a rapid uncontrolled descent
- Door rubbers on the posts protect the car doors from direct contact, and sill protector rubbers on the upper arms perform the same function protecting the undersides of longer chassis vehicles
- Mount the control box on either post; drive vehicles on or reverse them on

12 MONTHS PARTS & LABOUR WARRANTY*



- Minimum pad height 110mm
- Drive-thru width 2486mm
- Maximum Lifting Height 1850mm
- Lifting time 40-50sec
- Lowering time 20-40sec



MANUAL LOCKS 1 Phase
577 01 0060

WEEKLY FROM ONLY **£10.31⁺**
ONLY **£2,045.00**

ELECTRONIC LOCKS 1 Phase
577 01 0070

WEEKLY FROM ONLY **£11.82⁺**
ONLY **£2,345.00**

ELECTRONIC LOCKS 3 Phase
577 01 0080

WEEKLY FROM ONLY **£11.82⁺**
ONLY **£2,345.00**

* Warranty is subject to maintenance and terms and conditions

DUNLOP DL240M

12 MONTHS PARTS & LABOUR WARRANTY*
INCLUDES 1 YEAR FREE MAINTENANCE CONTRACT**



Two Post Electro-hydraulic Lift

- 1780mm lifting height
- 4 Tonne lifting capacity
- Manual Locks
- Free high lift pad adaptors
- New 2017 model



* Warranty is subject to maintenance and terms and conditions
**Includes 1 service at 6 months, and 1 service at 12 months

DUNLOP DL240M 1PH
577 77 7630

WEEKLY FROM ONLY **£10.56⁺**
ONLY **£2,095.00**

DUNLOP DL240M 3PH
577 77 7620

WEEKLY FROM ONLY **£10.56⁺**
ONLY **£2,095.00**

DUNLOP DL240

577 77 7330

12 MONTHS PARTS & LABOUR WARRANTY*
INCLUDES 1 YEAR FREE MAINTENANCE CONTRACT**

- Single or three phase
- 4 Tonne lifting capacity
- 1800mm lifting height
- Electronic Locks
- Anti toe trap devices on arms
- Minimum pad height of 110mm
- H type supportive base frame
- Available in single or three phase
- Suitable for lifting most cars and car derived vans

* Warranty is subject to maintenance and terms and conditions

**Includes 1 service at 6 months, and 1 service at 12 months



WEEKLY FROM ONLY **£12.07⁺**
ONLY **£2,395.00**



*Finance example typically based on a 5 year lease purchase agreement. Finance subject to status, full terms and conditions available on request. Other finance options available. All prices exclude VAT at 20%. Price, availability and specification may change without prior notice. Warranty subject to manufacturers terms and conditions of use. Errors and omissions excluded. Offers valid until 31st December 2017. Prices correct at time of going to press: October 2017.



Base Frame 2 Post Lifts

NO HASSLE WARRANTY
BEST PRICE PROMISE

BRADBURY HYDRAULIC 2 POST LIFTS

- Baseless option also available – ideal for transmission jacks
- 3 stage arms and large, adjustable dual screw lifting pads
- Electro-mechanical locking device
- Easy access for cable adjustment

BRADBURY H2601/3

6t standard length posts



WEEKLY FROM ONLY **£24.67⁺**
ONLY £4,885.00

FREE SET OF 200MM LIFT PAD ADAPTORS

BRADBURY H2601/3

6t extra height posts



WEEKLY FROM ONLY **£26.18⁺**
ONLY £5,195.00

FREE SET OF 200MM LIFT PAD ADAPTORS

BRADBURY H2401/3

4t standard length posts



WEEKLY FROM ONLY **£16.86⁺**
ONLY £3,345.00

BRADBURY H2401/3

4t extra height posts



WEEKLY FROM ONLY **£17.87⁺**
ONLY £3,545.00



TECALEMIT SF/9207 – SENTINEL 4 TON HYDRAULIC 2 POST LIFT WITH BASE FRAME AND 3 STAGE ARMS

The SF 9207 is mounted on a heavy duty steel base frame which ensures a stable lifting platform and the minimum lifting pad height of only 100mm ensures that even vehicles with low ground clearance can be accommodated on the lift.

The lift has 3 stage arms enabling the lift to be used on a wider range of vehicles.

- Electro-hydraulic operation
- Asymmetric lifting arms 3 stages for lifting a wide range of vehicles
- Rapid lifting time
- Structural base frame
- Electronically controlled safety latches

577 77 0370



WEEKLY FROM ONLY **£16.61⁺**
ONLY £3,295.00

577 77 0360



WEEKLY FROM ONLY **£16.61⁺**
ONLY £3,295.00



INCLUDES FREE HIGH LIFT PADS



TECALEMIT SF/8909/H – AZUR 3 TON 2 POST LIFT WITH BASE FRAME

576 77 0230

- Suitable for lifting most passenger cars and car derived vans
- Automatic arm locking
- 5 Year warranty on self-lubricating Nylatron operating and safety nuts
- Low minimum lifting pad height of just 90mm
- Foot/toe protection device using an audible buzzer
- Heavy duty base-frame

WEEKLY FROM ONLY **£13.58⁺**
ONLY £2,695.00



*Finance example typically based on a 5 year lease purchase agreement. Finance subject to status, full terms and conditions available on request. Other finance options available. All prices exclude VAT at 20%. Price, availability and specification may change without prior notice. Warranty subject to manufacturers terms and conditions of use. Errors and omissions excluded. Offers valid until 31st December 2017. Prices correct at time of going to press: October 2017.

BENDPAK XPR SERIES BASEFRAME LIFTS

NEW UPDATED MODELS

Low-profile, dropped-end frame c/w **NEW** screw contact pads

Squeeze under even the lowest compact and sport vehicles. The new adjustable screw pads ensure that the vehicle is lifted safely at all times

Triple-telescoping front arms and two-stage rear arms

Increases overall arm positioning for lifting a variety of different wheel base vehicles. Overall arm sweep and minimum arm reach are also extended to precisely lift vehicles that have unibody construction, OEM recommended pick-up points and wide and / or narrow wheelbase configurations.



3 YEARS WARRANTY

- 51mm Double screw adapter pads as standard on XPR9 & 10 Series.
- 4-Piece, 63mm stackable pad height adapter set included as standard on XPR9 & 10 Series. (Other lifting adapters are available)
- 8-Piece 63mm & 125mm stackable pad height adapter set included as standard on XPR12 series.
- 1308mm Lifting Arms on XPR9 & 10 Series.
- 1500mm Lifting Arms on XPR12 series.
- 1800mm Lifting Arms on LWB versions.
- 3-phase standard available with single phase motor at no additional cost.

XPR9TS 577 77 0870

1 or 3 phase 4t 102mm 3yr WARRANTY

WEEKLY FROM ONLY **£16.10⁺**
ONLY **£3,195.00**

XPR12FDL 577 77 0030

1 or 3 phase 5.4t 127mm 3yr WARRANTY

WEEKLY FROM ONLY **£25.14⁺**
ONLY **£4,989.00**

XPR12FDL-LWB 577 77 0070

1 or 3 phase 5.4t 127mm 3yr WARRANTY

WEEKLY FROM ONLY **£26.49⁺**
ONLY **£5,255.00**

NOW SUPPLIED WITH ADJUSTABLE HEIGHT SCREWPADS AS STANDARD

CASCOS 2 POST LIFTS

- Traditional Build Quality – ‘like lifts used to be’
- Symmetric arms enable approach from either direction
- Tool trays to arms
- Electro-mechanical operation for low cost of ownership and virtually maintenance-free

CASCOS C2.32 577 77 0200

- 3200kg Lifting Capacity
- Unique ‘twin insert’ lifting pads eliminate the need to buy additional high reach pads
- Available in based or baseless versions
- Available in 1ph or 3ph

1 or 3 phase 3.2t 100mm 3yr WARRANTY

WEEKLY FROM ONLY **£16.10⁺**
ONLY **£3,195.00**

CASCOS C4XL 576 77 0010

- 4000kg Lifting Capacity
- ‘Slendertec’ columns and triple stage arms, triple stage arms for universal vehicle coverage
- Unique ‘quick release’ lifting pads included – no additional extras

1 or 3 phase 4t 130mm 3yr WARRANTY

WEEKLY FROM ONLY **£22.65⁺**
ONLY **£4,495.00**



CASCOS C5 576 77 0250

- 5000kg Lifting Capacity
- Available in based or baseless versions

1 or 3 phase 5t 145mm 3yr WARRANTY

WEEKLY FROM ONLY **£31.73⁺**
ONLY **£6,295.00**

*Finance example typically based on a 5 year lease purchase agreement. Finance subject to status, full terms and conditions available on request. Other finance options available. All prices exclude VAT at 20%. Price, availability and specification may change without prior notice. Warranty subject to manufacturers terms and conditions of use. Errors and omissions excluded. Offers valid until 31st December 2017. Prices correct at time of going to press: October 2017.

LIFTMASTER LMS SERIES

2 YEARS WARRANTY

- Built in Germany and approved by multiple vehicle manufacturers for their workshops.
- This series of lift is available with 3.0T or 3.5T capacity.
- Electro-Mechanical Operation with low wear nylatron-nut means quiet operation.
- 5 years warranty on spindle and spindle-nuts.
- Driven by twin motors integrated into columns.
- The baseless lift gives an unobstructed floor space between the posts which allows Technicians to easily move tool boxes, transmission jacks, oil drainers and other service equipment underneath the elevated vehicle.
- Triple reach telescopic asymmetric front lifting arms means lifting points are easily reached.
- Low lifting point (from 75mm using Minimax Arms) allows vehicles with lower clearance to be lifted.
- This asymmetric Lift allows the vehicles' doors to be opened wider.
- Height adjustable gantry at the top connection at time of installation.



LMS3000MM

Standard configuration 576 77 0480



WEEKLY FROM ONLY **£20.64⁺**
ONLY £4,096.00

LMS3000TRA

with 3-stage arms 577 77 0120



WEEKLY FROM ONLY **£16.01⁺**
ONLY £3,176.00

LMS3500TRA

3.5t version 576 77 0490



WEEKLY FROM ONLY **£18.87⁺**
ONLY £3,745.00

LMS3500MM

3.5t version 576 77 0510



WEEKLY FROM ONLY **£23.49⁺**
ONLY £4,660.00

HOFMANN MEGAPLAN MEGALIFT 4500XL

577 77 7610

This 2 Post lift electro-hydraulic lift represents what happens when expertise meets extensive component sourcing, combining an economic design typical of entry-level commercial two post lifts, but with the added peace of mind of being specified and designed to be a Hofmann Megaplan product, with all its associated qualities such as build, reliability, long-term spares availability and reputation.

- 4500kg Lifting capacity with unique XL (extended length) Arms for increased commercial vehicle coverage
- High Reach Extensions included as standard
- European Design, typical Hofmann Megaplan Build Quality
- Convenient, efficient 1ph & 3ph operation
- 2 Year Warranty

WEEKLY FROM ONLY **£16.61⁺**
ONLY £3,295.00



*Finance example typically based on a 5 year lease purchase agreement. Finance subject to status, full terms and conditions available on request. Other finance options available. All prices exclude VAT at 20%. Price, availability and specification may change without prior notice. Warranty subject to manufacturers terms and conditions of use. Errors and omissions excluded. Offers valid until 31st December 2017. Prices correct at time of going to press: October 2017.

Baseless Lifts

NO HASSLE WARRANTY

BEST PRICE PROMISE

BENDPAK XPR SERIES BASELESS LIFTS

3 YEARS WARRANTY

The XPR-Series offers an abundant roster of options and accessories that allows you to fully tailor your lift to your unique circumstance

Wide or Narrow configurable options

Specific models in the range feature an adjustable top beam to accommodate wide or narrow installation setups. This unique configurable design allows you to choose the best setting for your specific space or vehicle lifting requirements.

Optional column height extension

Specific models in the range feature optional post extensions for extra height. This gives you the flexibility of increasing the overhead clearance to maximize the vehicles you can service.



NOW SUPPLIED WITH ADJUSTABLE HEIGHT SCREWPADS AS STANDARD

XPR10TS
577 77 0240



WEEKLY FROM ONLY **£15.11⁺**
ONLY £2,999.00

XPR10TS-168
577 77 0080



WEEKLY FROM ONLY **£19.13⁺**
ONLY £3,795.00

XPR12CL-192
577 77 0170



WEEKLY FROM ONLY **£28.70⁺**
ONLY £5,695.00

XPR12CL192-LWB
577 77 7450



WEEKLY FROM ONLY **£30.21⁺**
ONLY £5,995.00

LIFTMASTER LMH SERIES BASELESS LIFTS

5 YEARS WARRANTY

- Triple reach front arms (TRA) as standard
- Twin hydraulic rams on each post using a unique master and slave cylinder and powerful oil submerged motor configuration provides smooth and fast lifting and lowering times
- Synchronising cables are not required as the hydraulic system ensures fast and safe synchronisation at any level
- No need to lift before lowering to remove safety system as the load is secured hydraulically at any working height without the need of mechanical locking
- Self bleeding hydraulic system
- Low lifting point from 95mm (75mm with MM arms)
- Asymmetric arms for maximum door clearance
- Ergonomic design control lever

LMH3000MM
577 77 0490



WEEKLY FROM ONLY **£24.17⁺**
ONLY £4,795.00

LMH3000TRA
577 77 0700



WEEKLY FROM ONLY **£19.63⁺**
ONLY £3,895.00

LMH3500MM
577 77 0910



WEEKLY FROM ONLY **£27.46⁺**
ONLY £5,449.00

LMH3500TRA
577 77 7075



WEEKLY FROM ONLY **£22.65⁺**
ONLY £4,495.00

LMH4000MM
577 77 0500



WEEKLY FROM ONLY **£31.29⁺**
ONLY £6,209.00

LMH4000TRA
577 77 0800



WEEKLY FROM ONLY **£26.66⁺**
ONLY £5,289.00



3.5T BMW LIFT ALSO AVAILABLE

*Finance example typically based on a 5 year lease purchase agreement. Finance subject to status, full terms and conditions available on request. Other finance options available. All prices exclude VAT at 20%. Price, availability and specification may change without prior notice. Warranty subject to manufacturers terms and conditions of use. Errors and omissions excluded. Offers valid until 31st December 2017. Prices correct at time of going to press: October 2017.



Platform Scissor Lifts

NO HASSLE WARRANTY

BEST PRICE PROMISE

L3200S SHORT PLATFORM SURFACE MOUNTED SCISSOR LIFT

Ideal for service bays, tyre shops, general repair, brake repairs, suspension and transmission replacement, and body shops. Can handle almost all heavy-weight passenger cars derived vans. The ultra-low profile construction will accommodate most sports cars and other low skirted vehicles.

- Minimum pick-up height as low as 110mm, no problem for low-profile vehicles
- Design offers full access to front, rear, and sides of vehicle
- Supplied complete with sill-protecting rubber blocks
- Automatic activated safety lock through all lifting travel, easy pneumatic release
- Extendible platform length by utilising lockable approach ramps



L3200S 3 Phase
581 01 0150



WEEKLY FROM ONLY **£18.12⁺**
ONLY £3,595.00

L3200S 1 Phase
581 01 0090



WEEKLY FROM ONLY **£18.12⁺**
ONLY £3,595.00

BRADBURY H8 SERIES SHORT PLATFORM SCISSOR LIFTS

2 YEARS WARRANTY

INCLUDES 1 YEAR FREE MAINTENANCE CONTRACT*

Ideal for service bays, tyre shops, general repair, brake repairs, suspension and transmission replacement and body shops. Featuring a low profile platform ideal for lifting a large range of vehicles including low skirted sport cars.

Bradbury H8903/H8901E 3.2T extra low profile

Bradbury H8603/H8601E 3.6T Short Platform Recessed Scissor Lift

- Hydraulically synchronised platforms
- Improves utilisation of workshop space
- Full access to sides, front and rear of vehicle
- Ideal for service bays, tyre shops and general repair
- Complete with lifting blocks
- Safety valves detects hydraulic failure
- Overload mechanical safety device – Ratchet safety mechanism engages each time the lift stops throughout the lifting height of 1850mm
- Control panel allows precise lifting
- Reflector/light beam sensor ensures platform remains level during lift



Bradbury H8903E/H8901E

Bradbury H8603E/H8601E

H8903E

Surface mounted, 3 Phase
581 77 0090



WEEKLY FROM ONLY **£18.40⁺**
ONLY £3,650.00

H8603E

Recessed, 3 Phase
581 77 0070



WEEKLY FROM ONLY **£18.40⁺**
ONLY £3,650.00

H8901E

Surface mounted, 1 Phase
581 77 0100



WEEKLY FROM ONLY **£18.40⁺**
ONLY £3,650.00

H8601E

Recessed, 1 Phase
581 77 0080



WEEKLY FROM ONLY **£18.40⁺**
ONLY £3,650.00

*Includes 1 service at 6 months, and 1 service at 12 months

*Finance example typically based on a 5 year lease purchase agreement. Finance subject to status, full terms and conditions available on request. Other finance options available. All prices exclude VAT at 20%. Price, availability and specification may change without prior notice. Warranty subject to manufacturers terms and conditions of use. Errors and omissions excluded. Offers valid until 31st December 2017. Prices correct at time of going to press: October 2017.

0845 603 3636
OVER 200 BRANCHES NATIONWIDE

BENDPAK 4 POST SERVICE LIFTS – ROBUST AND RELIABLE

2 YEARS WARRANTY

- Electric / hydraulic power system with single hydraulic cylinder mounted underneath platform – less to go wrong
- Available with single phase or 3 phase electric motor at no additional cost with two power unit locations.
- Platforms accommodate narrow and standard vehicles.
- Push-button pneumatic safety release from multi-position safety locks in each column.
- Longer approach ramps for low-ground clearance vehicles (HDS14, 14X, 14LSX & 14LSXE)
- Wheel alignment lifts available (HDS14LSX & HDS14LSXE)



ADD A BENDPAK JACKING BEAM FROM ONLY £625 EXTRA

HD-9 4TON 4 Post Service Lift
with 4166mm platforms
578 77 0050

WEEKLY FROM ONLY **£17.61⁺**
ONLY **£3,495.00**

HD9XW 4TON 4 Post Service Lift
with 4775 mm platforms
578 77 0080

WEEKLY FROM ONLY **£19.08⁺**
ONLY **£3,785.00**

HDS-14 6.35TON
4 Post Service Lift, 3 Phase
578 77 0010

WEEKLY FROM ONLY **£27.19⁺**
ONLY **£5,395.00**

LGSS32 SHORT PLATFORM SURFACE MOUNTED SCISSOR LIFT 3.2TON

581 77 0290

2 YEARS WARRANTY

- Electro-hydraulic operation
- Surface mounted or recessed installation
- Low platform height
- 4 x Polymer pads (340mm x 150mm x 50mm) included
- Twin independent hydraulic circuits so no need for air locks
- Maximum use of workshop space
- Fast lifting and lowering times
- Clear access between the scissors
- No electrical or pneumatic components on the lift
- High quality steel construction ensures directional stability
- Quiet robust oil-submerged motor with push button control and lockable control unit.
- 3 phase electrics



WEEKLY FROM ONLY **£28.12⁺**
FROM ONLY **£5,580.00**



*Finance example typically based on a 5 year lease purchase agreement. Finance subject to status, full terms and conditions available on request. Other finance options available. All prices exclude VAT at 20%. Price, availability and specification may change without prior notice. Warranty subject to manufacturers terms and conditions of use. Errors and omissions excluded. Offers valid until 31st December 2017. Prices correct at time of going to press: October 2017.

Alignment 4 Post / Scissor Lifts

NO HASSLE WARRANTY

BEST PRICE PROMISE

BENDPAK 4 POST ALIGNMENT LIFTS – ROBUST AND RELIABLE

- Electric / hydraulic power system with single hydraulic cylinder mounted underneath platform – less to go wrong
- Available with single phase or 3 phase electric motor at no additional cost with two power unit locations.
- Platforms accommodate narrow and standard vehicles.
- Push-button pneumatic safety release from multi-position safety locks in each column.
- Longer approach ramps for low-ground clearance vehicles (HDS14, 14X, 14LSX & 14LSXE)
- Wheel alignment lifts available (HDS14LSX & HDS14LSXE)

ADD A BENDPAK JACKING BEAM FROM ONLY £750 EXTRA

2 YEAR WARRANTY



HDS14LSX 6.35TON
4 Post alignment Lift
with 5054 mm platforms
578 77 0090

WEEKLY FROM ONLY **£32.05⁺**
ONLY **£6,359.00**

HDS14LSXE 6.35TON
4 Post alignment Lift
with 5816mm platforms
578 77 0000

WEEKLY FROM ONLY **£34.47⁺**
ONLY **£6,839.00**

ALIGNMENT SCISSOR LIFTS

- Large platforms and a sturdy structure, assuring maximum rigidity and stability.
- Mechanical locking device with automatic engagement and pneumatic release, ensuring maximum safety.
- Where space is an issue, alignment scissor lifts are available with platform legs from 4.6m to 5.5m
- Platforms for total wheel alignment, with front radius plate locations and rear slip plates.
- Please note that the radius plates are not included, but available as an optional extra



WEEKLY FROM ONLY **£42.51⁺**
FROM ONLY **£8,435.00**

*optional secondary scissor lift shown

WERTHER 450 AT
578 77 0220

12 MONTHS WARRANTY

Electro-hydraulic 4 post lift with front recesses and rear slipping plates for wheel alignment.

- 4 Tonne lifting capacity
- Overload safety valve
- Descent control valve
- 'Buzzer' on last portion of descent
- Pipe burst safety valve
- 24V low tension dead man controls
- Automatic release of safety locking devices



WEEKLY FROM ONLY **£33.99⁺**
FROM ONLY **£6,745.00**

*Finance example typically based on a 5 year lease purchase agreement. Finance subject to status, full terms and conditions available on request. Other finance options available. All prices exclude VAT at 20%. Price, availability and specification may change without prior notice. Warranty subject to manufacturers terms and conditions of use. Errors and omissions excluded. Offers valid until 31st December 2017. Prices correct at time of going to press: October 2017.

0845 603 3636
OVER 200 BRANCHES NATIONWIDE

Alignment / Tyre Profiler

NO HASSLE
WARRANTY

BEST PRICE
PROMISE

BOSCH FWA4630+

587 77 2090

“Real 3D”, short setup times, simple operation, precise and fast results.

Once the vehicle has been driven onto the turn plates and sliding plates, the setup and measuring process will only take seven minutes. Unlike conventional run-out measurements, the vehicle can be driven rather than pushed, this is because of the high frequency cameras. Alignment can be carried out by a single technician even with SUVs or LCVs. The wheel alignment process itself is then simultaneously performed on all four wheels.

- Market leader in Accuracy & Repeatability
- 12 cameras takes 29 pictures per second – fastest in the industry
- Measures TOE/CAMBER/CASTER/SET BACK (front) and TOE/CAMBER/THRUST ANGLE/SET BACK (rear)
- Measuring time through to print out of results in 90 seconds
- Single person operation – no need to manually push the vehicle
- New software and user interface: perfectly geared to quick wheel alignment
- The FWA 4630+ has an OEM database which uses over 130 vehicle manufacturer data values

Included in the package:

- FWA 4630+ 3D reference system with 12 CCD stereo cameras
- Bosch trolley with 27” monitor, PC and printer
- 4 measuring boards
- Steering wheel & brake pedal lock
- 15m cable set
- 4 Multi-fit wheel clamps with special claws for UHP/RFT tyres
- 2 mechanical turntables



WEEKLY
FROM ONLY **£74.26⁺**
ONLY **£14,735.00**

ALSO AVAILABLE IS THE BOSCH DAS 1000 CAMERA SENSOR CALIBRATION SYSTEM FOR ADAS ASK BRANCH FOR DETAILS

DIGITAL TYRE TREAD PROFILER – STAND ALONE VERSION

587 77 2360

Features include:

- Automatically detects the tyre wear as vehicle drives through
- Quick diagnosis of tyre conditions
- Tyre profiler consists of two drive through platforms equipped with stereo cameras and a laser blade illuminator (red light)
- The system analyses two pictures taken from the cameras to measure the tread pattern and detects a section of the wheel rotation surface by epipolar geometry



Package includes:

- Set of 2 profiler platforms, including run-up and run-off ramps
- Cable covers
- Control unit with PC, 19” monitor and printer

WEEKLY
FROM ONLY **£56.19⁺**
ONLY **£11,149.00**

*Finance example typically based on a 5 year lease purchase agreement. Finance subject to status, full terms and conditions available on request. Other finance options available. All prices exclude VAT at 20%. Price, availability and specification may change without prior notice. Warranty subject to manufacturers terms and conditions of use. Errors and omissions excluded. Offers valid until 31st December 2017. Prices correct at time of going to press: October 2017.



JOHN BEAN V2200

587 77 0050

2 YEARS WARRANTY

Patented 3D imaging technology provides accurate and real-time measurements which improves productivity. User-friendly features such as EZ Toe, VODI and an extensive vehicle specification database delivers customer satisfaction, ease of use and accuracy.

- Motorised camera boom
The camera height adjustment is motorised providing ergonomic and time saving advantages.
- VODI (Vehicle Orientation Directional Indicators)
Monitor out of sight when making adjustments? VODI can provide a secondary visual allowing you to complete a job without stopping.
- Fast readings
The V2200's software, manufacturers' specifications and customisable options allow for full four-wheel alignment readings to be recorded in just minutes.
- Elevated adjustment
This function allows for live adjustment of suspension components when in an elevated position, saving you time and making your job easier.
- Alignment report
Print colour reports for your customers. The before and after illustration can help you communicate the benefits of wheel alignment simply and clearly.
- EZ Toe
Turn the front wheels and access difficult adjustment points while still displaying centred toe readings.
- Adjustment modes
Have access to a wide range of adjustment modes, including A-arm and cradle adjustment.
- Measurement options
- Extensive database
- Wheel clamps
The V2200 has universal wheel clamping up to 26" (with additional adaptors).

**V2200 + 4TON 5.2M
ALIGNMENT LIFT PACKAGE**
587 77 182P

WEEKLY
FROM ONLY **£85.66⁺**
ONLY **£16,996.00**

**ASK FOR
DETAILS**

WEEKLY
FROM ONLY **£45.35⁺**
ONLY **£8,999.00**

JOHN BEAN V2400

587 77 2110

2 YEARS WARRANTY

The John Bean V2400 offers advanced features that grow business for high-volume garages and dealerships, and is an ideal investment for bodyshops.

All the features of the V2200 plus:

- Measurement of toe, camber, caster, maximum steering angle, rolling radius and cross diagonal
- ProAckermann, graphical caster trail, scrub radius and steering axis inclination
- A-arm and cradle adjust
- EZ Toe for easy and convenient adjustment at maximum steering angle
- EZ Access for measurement with demounted wheels
- Target Imaging Pointer for ride height measurement

WEEKLY
FROM ONLY **£79.35⁺**
ONLY **£15,745.00**



*Finance example typically based on a 5 year lease purchase agreement. Finance subject to status, full terms and conditions available on request. Other finance options available. All prices exclude VAT at 20%. Price, availability and specification may change without prior notice. Warranty subject to manufacturers terms and conditions of use. Errors and omissions excluded. Offers valid until 31st December 2017. Prices correct at time of going to press: October 2017.

NO HASSLE WARRANTY

BEST PRICE PROMISE

HD MEGALINE SSENCE 600 3D WHEEL ALIGNER 587 77 2130

NEW

The Megaline Ssence 600 3D - HD represents the very latest High Definition 3D wheel alignment technology. It utilises smaller 'reflective targets' and high definition head and camera system to give precise results in a wide variety of conditions. It's fast, simple, and ideal for those customers looking to invest in the most advanced wheel alignment capability available on today's market. The software has been upgraded, to allow for simpler manufacturer and model searches. The interface explains the alignment process step by step to even the least experienced of alignment technician, minimising unnecessary procedures commonly found on other, similar systems.

The super-advanced 600 HD, comes with 32" display and automatic camera bar. You can be guaranteed a product that will earn you thousands of pounds in valuable extra revenue and keep your workshop at the cutting edge of wheel alignment geometry.

- NEW: More accurate HD cameras
- Less light pollution due to sharper imagery
- Works in a range of lighting situations including low light and 'glaring' sun
- Most precise results
- NEW: Smaller, lighter targets
- Works with a greater number of lifts
- Easier to position, easy to use
- NEW: Updated interface with intuitive search function
- Even less light pollution due to sharper HD images
- Large 32" monitor
- Fully-Automatic camera boom
- Includes Autodata database
- Includes mechanical turnplates
- Latest alignment technology



ASK FOR A DEMO

WEEKLY FROM ONLY **£55.43⁺**
FROM ONLY **£10,999.00**

MEGALINE SSENCE 600 HD + ALIGNMENT LIFT PACKAGE 587 77 009P

- Ssence 600HD Aligner
- 4T 4 post alignment lift
- Jacking Beam

WEEKLY FROM ONLY **£75.59⁺**
FROM ONLY **£14,999.00**



**ADD A MEGATAB
(WORTH £995 FOR ONLY £495)**

*Finance example typically based on a 5 year lease purchase agreement. Finance subject to status, full terms and conditions available on request. Other finance options available. All prices exclude VAT at 20%. Price, availability and specification may change without prior notice. Warranty subject to manufacturers terms and conditions of use. Errors and omissions excluded. Offers valid until 31st December 2017. Prices correct at time of going to press: October 2017.



NO HASSLE WARRANTY

BEST PRICE PROMISE

HOFMANN MEGAPLAN ECOLINE 58/88 – FULLY COMPUTERISED WHEEL ALIGNMENT WITH A4 PRINTER

Bridging the gap between laser alignment and fully computerised systems with printout, which traditionally made the jump too big for many workshops.

Ecoline 58 and 88 are supplied with a comprehensive vehicle database from the recognised industry name, Autodata, and offers a before and after printout. The Ecoline series – is the logical choice for anybody wanting to move into advanced vehicle geometry without the cost traditionally associated with computerised systems.

Only one alignment a week turns this investment into profit!

ECOLINE 58/88 FEATURES

- Simple to use – faster readings, saves time increasing your profit
- Supplied with PC, 19" monitor – clear impressive graphics with onscreen instructions
- Onsite training – your machine, your premises Hofmann Megaplan's specialists
- Comprehensive Vehicle Database by Autodata – over 17,000 models from 80 manufacturers
- A4 Printer – Provides before and after readings for customers
- Traditional 4-Point Clamps (58 only) – handles up to 23" rims as standard
- Front Cameras and Rear Sensors – increases accuracy and repeatability
- Zigbee® wireless communication – offers stronger and more reliable signal over Bluetooth®

ECOLINE 88 ONLY FEATURES

- 3 Point 'Grab Clamps' – even faster mounting, saves more time
- Front & Rear Cameras – ideal for advanced geometry when speed is needed



ECOLINE 58
587 77 1340

WEEKLY FROM ONLY **£20.64⁺**
ONLY **£4,095.00**

ECOLINE 88
587 77 1270

WEEKLY FROM ONLY **£27.69⁺**
ONLY **£5,495.00**

JOHN BEAN PRISM ELITE

The Visualiner Prism Elite allows you to add alignment to your garage services without needing to hire an experienced alignment technician.

Plus, not only will you be able to pinpoint alignment problems, it generates reports that can be shared with customers, which is why your alignment business will start growing from day one.

If you already own a John Bean Geogas 3000 or 5000 Emissions Analyser, you can add a Prism kit to this unit – saving you space in your workshop and allowing your MOT bay to carry out alignments.

Computerised wheel alignment with Pro 42 software.

- Accurate, flexible and easy to service
- Perform alignments quickly from virtually anywhere in the workshop
- Integrated help system
- Extensive manufacturers' specification database

SHARING THE GEOGAS PC
587 77 1130

WEEKLY FROM ONLY **£31.73⁺**
ONLY **£6,295.00**

STANDALONE PRICE
587 77 0570

WEEKLY FROM ONLY **£34.37⁺**
ONLY **£6,820.00**



*Finance example typically based on a 5 year lease purchase agreement. Finance subject to status, full terms and conditions available on request. Other finance options available. All prices exclude VAT at 20%. Price, availability and specification may change without prior notice. Warranty subject to manufacturers terms and conditions of use. Errors and omissions excluded. Offers valid until 31st December 2017. Prices correct at time of going to press: October 2017.

LITE ALIGN 450 WALL MOUNTED

587 77 0020

Wall mounted car and light commercial four wheel laser aligner kit. Includes two front laser heads, two rear flag units, brake pedal depressor, steering clamp, turn discs, wall mount rack and 100mm rim buttons

MEASURES:

- Front and rear individual and total toe, to ensure correct tracking and stability on the road
- Thrust Line, to make sure the rear wheels are pointing in the straight ahead position in relation to the centre line of the vehicle
- Set back, to check front and rear wheels to ensure correct alignment across the vehicle
- Corrects steering wheel alignment. Rear flags enable the end user to adjust the alignment to achieve perfect steering wheel alignment first time.

KEY FEATURES:

- Unique tyre/wheel mounting system, resulting in more accurate measurement, reduced risk of heads becoming detached during adjustments
- Rechargeable battery operation, no cables
- Fits 12 to 22 inch wheels, cars and light commercials, XL kit available for larger wheels
- Optional digital Camber/Caster/SAI gauge available



WEEKLY FROM ONLY **£8.06⁺**
ONLY **£1,599.00**

LITE ALIGN 450 WALL MOUNTED WITH MAGNETIC CASTER CAMBER GAUGE

587 77 0640

Wall mounted car and light commercial four wheel laser aligner with magnetic caster camber gauge. Includes two front laser heads, two rear flag units, brake pedal depressor, steering clamp, turn discs, wall mount rack and 100mm rim buttons.

WEEKLY FROM ONLY **£9.55⁺**
ONLY **£1,895.00**

LITE ALIGN LA650

587 77 1390

ASK FOR A DEMO

Computer 4 Wheel Laser Aligner*

- Fits on practically car and light commercials, 12" to 22" wheels as standard (depending on tyre size – optional larger head and rim buttons also available)
- Ultra-low measuring position on front heads (enables use on vehicles with low body clearance)
- Measures: Individual Toe, Set Back, Caster, Camber, Thrust Line and Steering Wheel Position
- Zigbee wireless technology sends information to customer-supplied laptop/PC
- Live readings on computer screen, live readings displayed on gauges can also be used without a computer.
- Provides 'Before' and 'After' printout of results
- Provides Autodata database with red/green readability
- Provides tutorials on adjustments required to correct alignment errors - with pictures
- Customers own user data can be entered into database
- On site installation/training provided on delivery
- On-rack charging battery operation (no cables)



Included in the package:

- Lite Align LA650 aligner (*computer not supplied)
- 1 pair turnplates,
- Software/ dongle to install on customers own PC/laptop.
- Autodata database
- Steering wheel clamp
- Brake pedal depressor
- On-site installation and training
- Twin built in camber/caster/sai gauges



WEEKLY FROM ONLY **£18.12⁺**
ONLY **£3,595.00**

ASK FOR A DEMO

*Computer not included

*Finance example typically based on a 5 year lease purchase agreement. Finance subject to status, full terms and conditions available on request. Other finance options available. All prices exclude VAT at 20%. Price, availability and specification may change without prior notice. Warranty subject to manufacturers terms and conditions of use. Errors and omissions excluded. Offers valid until 31st December 2017. Prices correct at time of going to press: October 2017.

HOFMANN MEGALINE 4 – WALL MOUNTED OR TROLLEY LASER ALIGNMENT SYSTEM

Proven in hundreds of tyre shops and garages throughout the UK as a highly profitable and technically valuable system. Individual front and rear toe, rear thrust line, set back and steering wheel position can all be achieved in just a matter of minutes.

Supplied with all necessary accessories including pedal depressor, steering wheel holder and extensions for lowered vehicles, light commercials and 4x4s, the megaline system 4 is a must for anybody involved in vehicle servicing or tyres.

The megaline system 4 represents a great profit opportunity, as it can be installed for as little as £15 + VAT per week - that's just one alignment per week to pay for the system! The very latest design ensures maximum vehicle coverage including rims from 12" to 23", and the clever 'prism' design of the lasers minimises costly and vulnerable components within the measurement heads.

- Simple, speedy 'hang-on' heads
- Laser accuracy
- Handles rims up to 23"
- Supplied with necessary accessories
- Low cost means fast return on investment

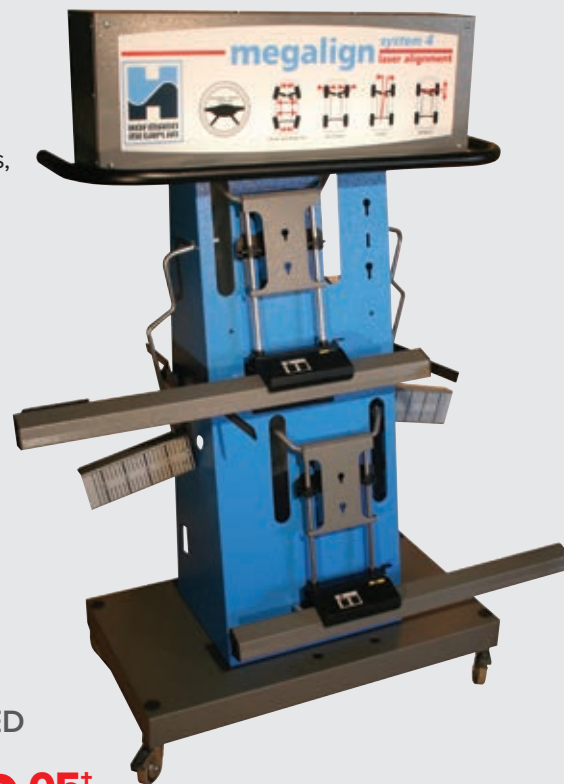

SYSTEM 4WE – WALL MOUNTED WITHOUT LIGHTBOX
587 77 1330

WEEKLY FROM ONLY **£9.80⁺**
ONLY **£1,945.00**

SYSTEM 4T – PORTABLE TROLLEY
587 77 0040

WEEKLY FROM ONLY **£12.57⁺**
ONLY **£2,495.00**

SYSTEM 4W – WALL MOUNTED
587 77 1320

WEEKLY FROM ONLY **£10.05⁺**
ONLY **£1,995.00**

JOHN BEAN A300/A350

The John Bean wall or trolley-mounted four-wheel laser alignment system is a highly profitable and technically valuable tool.

Individual front and rear toe, rear thrust line, set back and steering wheel position can all be achieved in just a matter of minutes.

The unit is designed to ensure that it is able to cover the vast majority of vehicles in the market, including rims from 12 inches to 23 inches.

- Wheel rims – 12 inches to 23 inches
- Alloy friendly clamp contact
- Turn plates included
- Continual operation up to 8 hours
- 2 Year warranty



A300 LASER WHEEL ALIGNER – WALL MOUNT
587 77 0300

WEEKLY FROM ONLY **£10.52⁺**
ONLY **£2,087.00**

A350 LASER WHEEL ALIGNER – TROLLEY MOUNT
587 77 0310

WEEKLY FROM ONLY **£12.07⁺**
ONLY **£2,395.00**

*Finance example typically based on a 5 year lease purchase agreement. Finance subject to status, full terms and conditions available on request. Other finance options available. All prices exclude VAT at 20%. Price, availability and specification may change without prior notice. Warranty subject to manufacturers terms and conditions of use. Errors and omissions excluded. Offers valid until 31st December 2017. Prices correct at time of going to press: October 2017.

Heating – Suspended Units

NO HASSLE WARRANTY

BEST PRICE PROMISE

AMBIRAD GAS RADIANT HEATERS

Suspended gas fired radiant tube heaters delivering exceptional efficiency and the potential to reduce energy costs. Suitable for showrooms, workshops, bodyshops and storage facilities.

There are three vision ranges:

1. VSX range

High efficiency with recuperative heat exchanger; available as a 'U' tube model

2. VS range

Complete with stainless steel reflectors and endcaps, is available in 'U' tube, single linear and double linear models and can be mounted in linear or U tube herringbone configurations.

3. VSA range

Complete with aluminised reflectors and endcaps, which is available in 'U' tube, single linear and double linear models and can be mounted in linear or 'U' tube herringbone configurations.

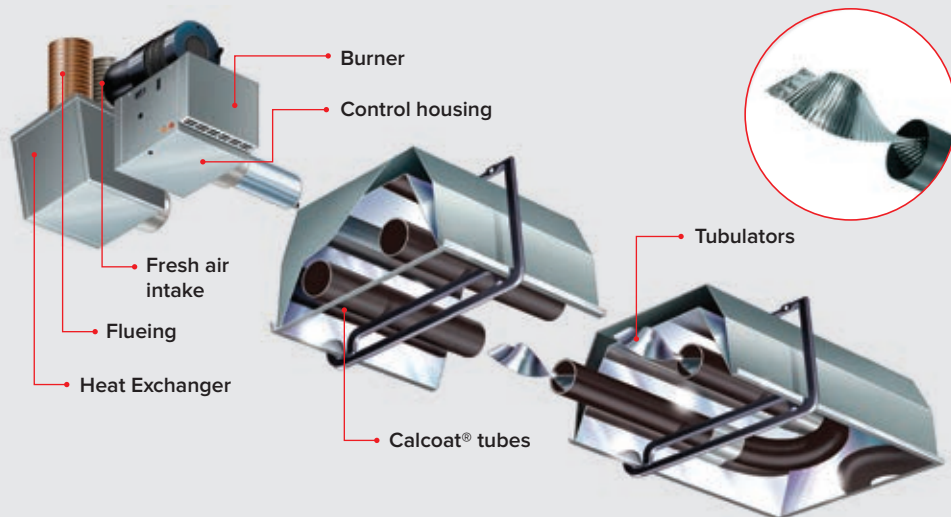

Standard radiant heater

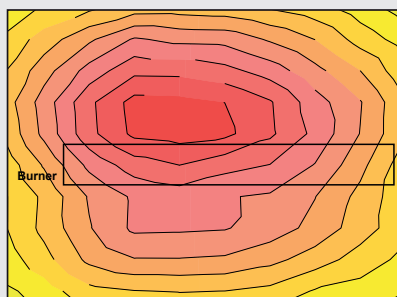

Vision (VSX)

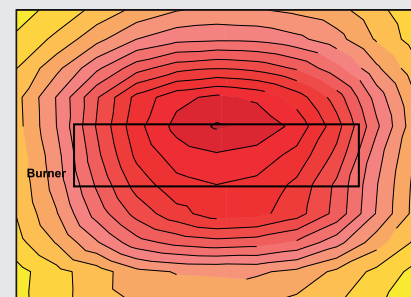

Vision improves temperature distribution along the entire length of the heater.

CALL FOR A QUOTE

AMBIRAD ULTRA GAS HEATERS

Suspended gas fired unit heaters with clean aesthetic lines and configured for either room sealed or conventional flue applications. Suitable for showrooms, workshops, and bodyshops. Off-floor mounting provides an ideal solution where floor space is at a premium.

The ULTRA exceeds European norms for efficiency and the lowest NO_x and CO₂ emissions.

The design of this gas fired unit heater combines high thermal efficiency, quality components and ease of maintenance for enhanced life expectancy and reduced life cycle costs. In conventional unit heaters, some of the heat is lost in the flue gases. In the AmbiRad ULTRA, these flue gases are led through a second heat exchanger which cools them down to a temperature below the dew point. This way, water vapour will condense and release its latent heat into the air flow.

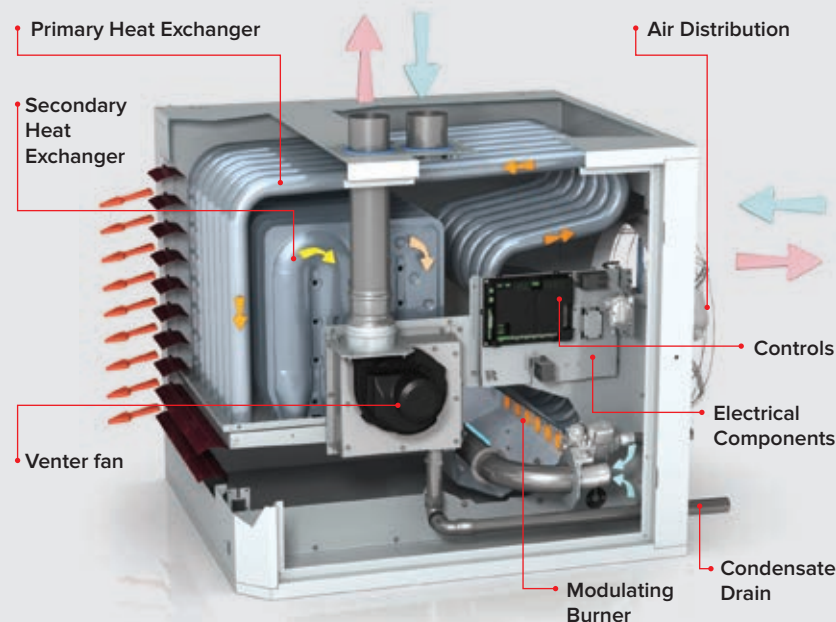

Traditional unit heater

Higher roof space temperatures increase heat loss through roof

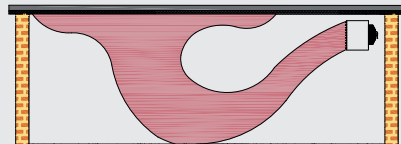

Shorter air throws reduce air distribution efficiency and require longer pre-heat times

ULTRA heater

Reduced floor to ceiling temperature gradients

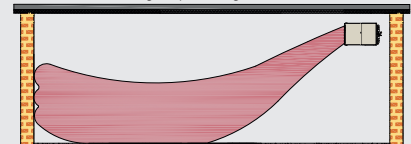

Longer air throws provide even heat distribution and reduce pre-heat times

CALL FOR A QUOTE

*Finance example typically based on a 5 year lease purchase agreement. Finance subject to status, full terms and conditions available on request. Other finance options available. All prices exclude VAT at 20%. Price, availability and specification may change without prior notice. Warranty subject to manufacturers terms and conditions of use. Errors and omissions excluded. Offers valid until 31st December 2017. Prices correct at time of going to press: October 2017.

Selecting the Right Heater



If you want to maintain productivity, you have to maintain the correct working temperature but there's a lot to consider... The size and shape of your workshop, insulation levels and working characteristics (e.g. regular opening of large shutters) are all part of the calculation. You also have to consider the type of heater, fuel, and the controls you can implement to minimise heat loss. Our experienced Projects team will help tailor the perfect package for you.

TYPE OF FUEL

Your office or customer reception heating may be fuelled by electricity but it's far too expensive for larger commercial spaces. The best value fuel maybe affected by external economic factors and also by its availability to your unit. Natural Gas, Propane, Red Diesel and Kerosene are all options.

TYPE OF HEATER

Radiant heaters are often used in areas with high air movement – near frequently opened doors – or where there is a need for zonal heating. Radiant heat warms all solid objects and surfaces in its path. Heat energy passes inertly through the air, dissipating as heat upon contact with people and surfaces so, while within the zone of a radiant heater, people can remain comfortable at lower air temperatures, reducing wasteful heating of unoccupied space.

In buildings where doors are shut most of time and full heating of the space is required, warm air heaters provide the best and most economical solution.



ACCESSORIES

We've all heard the phrase warm air rises but it's not exactly efficient to heat the top of your workshop when you need that heat at floor level. This is where strategic use of destratification fans and electronic controls become the final piece of the jigsaw, maximising your heating efficiency and giving you complete control.

Destratification fans in your roof space bring down otherwise wasted warm air to where you need it. If correctly designed and installed a destratification system can save up to 30% on running costs.

Electronic controls optimise heater control, complying with the latest Building Regulations. They can be password protected and programmed to turn heaters off when roller shutter doors are left open too long, ensuring you're heating your building not the outside world.



SmartCom³ control panel



Radiant black bulb sensor

HOW TO CALCULATE THE AMOUNT OF HEAT OUTPUT REQUIRED

The amount of heat required to raise the temperature of a space by 20° (e.g. ambient temperature is -5°C, required temperature is +15°C) is dictated by the volume of space to be heated, and the rate of heat loss to the environment.

| WHAT IS YOUR BUILDING HEAT LOSS FACTOR? | LOSS FACTOR |
|---|---------------|
| No insulation (e.g. corrugated sheet), shutter doors frequently opened | 9 Btu/cu.ft |
| Poor insulation (e.g. single skin brick or block), single glazed windows, shutter doors opened fairly frequently | 6.8 Btu/cu.ft |
| Average insulation (e.g. double skin brick or block), single glazed windows, insulated roof space, shutter doors mostly closed | 5 Btu/cu.ft |
| Good insulation (e.g. breeze blocks plus cladding, with insulation between), double glazed windows, shutter doors mostly closed | 2.7 Btu/cu.ft |

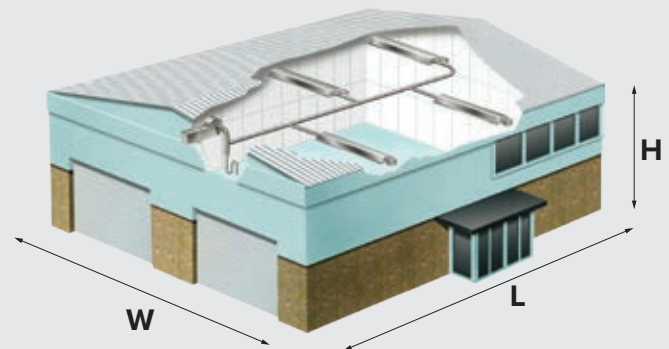

- Multiply Length x Width x Height of heating area and get the building volume.
_____ x _____ x _____ = _____ cu.ft.
- Select the description which best suits the area to be heated
- Multiply the building volume by the heat loss factor.
_____ cu.ft. x _____ Btu/cu.ft = _____ Btu

The heater units produce a range of outputs and will be chosen to give you the right heating system at the right price. Use the heat calculation to determine the amount of heat needed, and call us for a quote.

3412Btu/h = 1kW/h

*Finance example typically based on a 5 year lease purchase agreement. Finance subject to status, full terms and conditions available on request. Other finance options available. All prices exclude VAT at 20%. Price, availability and specification may change without prior notice. Warranty subject to manufacturers terms and conditions of use. Errors and omissions excluded. Offers valid until 31st December 2017. Prices correct at time of going to press: October 2017.

THERMOBILE UNIVERSAL OIL HEATERS

Floorstanding, manual ignition, virtually soot-free oil-burning* heaters. Suitable for general automotive workshops, the AT307 produces radiant heat, whilst the other models, being fan assisted, produce warm air heating.

Supplied complete with a flue kit and setup instructions, these heaters do not require specialist engineer installation. Enclosed-flame setup (not available on AT306 and AT307 Thermo) ensures odour-free and efficient combustion.

The high efficiency of the AT400 and AT500 is achieved by a built-in, large surface heat exchanger, through which all the gases have to pass before entering the flue.

SUPPLIED WITH STANDARD FLUE KIT

EXCLUSIVE 2 YEAR WARRANTY



AT307
594 77 1340



WEEKLY FROM ONLY **£8.04⁺**
ONLY **£1,595.00**



AT306
594 77 1330



WEEKLY FROM ONLY **£6.22⁺**
ONLY **£1,235.00**



AT306 TERMO
594 77 1750



WEEKLY FROM ONLY **£5.54⁺**
ONLY **£1,099.00**



AT400
594 77 1350



WEEKLY FROM ONLY **£10.99⁺**
ONLY **£2,180.00**



AT500
594 77 1360



WEEKLY FROM ONLY **£12.95⁺**
ONLY **£2,569.00**

FLUE BOOSTER

594 77 2260

The Heater Booster simply slots between the heater and the flue and increases the heater's output utilising the heat that would normally be lost through the flue.

- Suitable for models AT306, AT306T, AT307, AT400
- Simply slots into 150mm diameter flue pipe system
- A 220-240V supply is required for the fan

ONLY **£295.00**



*Heaters operating on Used Oil require a relevant permit under Schedule 13A of the Environmental Permitting Guidance (EPR). There will be requirements placed on emissions monitoring and operational control procedures.

*Finance example typically based on a 5 year lease purchase agreement. Finance subject to status, full terms and conditions available on request. Other finance options available. All prices exclude VAT at 20%. Price, availability and specification may change without prior notice. Warranty subject to manufacturers terms and conditions of use. Errors and omissions excluded. Offers valid until 31st December 2017. Prices correct at time of going to press: October 2017.

THERMOBILE OIL FIRED CABINET HEATERS

Factory set for either for either Diesel 35 second or Kerosene 28 second fuel oil, your choice!

- 91% efficiency models
- Inbuilt Thermostat Timer
- Combustion Air intake kit included as standard
- Output range across the models from 380kW to 501kW
- 12 months parts & labour warranty plus a further 12 months parts only warranty

BSO 30

BSO 30 OIL-FIRED CABINET HEATER
HEAT OUTPUT 109,000 BTU/H
594 77 0320

WEEKLY FROM ONLY **£10.92[†]**
ONLY ~~£2,166.00~~

BSO 40

BSO 40 OIL-FIRED CABINET HEATER
HEAT OUTPUT 146,000 BTU/H
594 77 0300

WEEKLY FROM ONLY **£11.84[†]**
ONLY ~~£2,349.00~~

BSO 60

BSO 60 OIL-FIRED CABINET HEATER
HEAT OUTPUT 203,000 BTU/H
594 77 1420

WEEKLY FROM ONLY **£13.43[†]**
ONLY ~~£2,665.00~~

BSO 85

BSO 85 OIL-FIRED CABINET HEATER
HEAT OUTPUT 280,000 BTU/H
594 77 0820

WEEKLY FROM ONLY **£14.31[†]**
ONLY ~~£2,839.00~~

BSO 120

BSO 120 OIL-FIRED CABINET HEATER
HEAT OUTPUT 418,000 BTU/H
594 77 1430

WEEKLY FROM ONLY **£17.33[†]**
ONLY ~~£3,439.00~~

FLUE KIT

FOR BSO 30 & 40
594 77 0310

ONLY **£281.00**

FLUE KIT

FOR BSO 60
594 77 1440

ONLY **£290.00**

FLUE KIT

FOR BSO 85 & 120
594 77 0670

ONLY **£300.00**



*Finance example typically based on a 5 year lease purchase agreement. Finance subject to status, full terms and conditions available on request. Other finance options available. All prices exclude VAT at 20%. Price, availability and specification may change without prior notice. Warranty subject to manufacturers terms and conditions of use. Errors and omissions excluded. Offers valid until 31st December 2017. Prices correct at time of going to press: October 2017.

THERMOBILE SB AUTOMATIC IGNITION HEATERS

- Multifuel capability, can also operate on heating oil or diesel
- Minimal maintenance heaters with clean, soot-free combustion
- 1 phase or 3 phase motors
- Fixed or rotatable vents for total control over air circulation
- Insulated panels for safety and efficiency

Up to 180,000 BTU 1 phase motors rotatable vent heaters with exclusive 2 years warranty only available from Workshop Solutions.

Supplied complete with a flue kit and setup instructions, these heaters do not require specialist engineer installation. However, a qualified electrician will be required to make the final connection to a 3 Phase supply.

**EXCLUSIVE
2 YEAR WARRANTY**



SB40 WASTE OIL HEATER
WITH FLUE KIT, MIN 140,000BTU/HR
594 77 1370

WEEKLY
FROM ONLY **£21.24⁺**
ONLY **£4,215.00**

SB60 WASTE OIL HEATER
WITH FLUE KIT, MIN 180,000BTU/HR
594 77 1380

WEEKLY
FROM ONLY **£23.41⁺**
ONLY **£4,645.00**

GREATER THAN 180,000BTU 3 PHASE MOTORS, ROTATABLE VENT HEATERS

SB80 WASTE OIL HEATER
WITH FLUE KIT, INCL. MOTOR &
PUMP KIT, MIN 270,000BTU/HR
594 77 1390

WEEKLY
FROM ONLY **£32.86⁺**
ONLY **£6,519.00**

SB110 WASTE OIL HEATER
WITH FLUE KIT, INCL. MOTOR &
PUMP KIT, MIN 390,000BTU/HR
594 77 1400

WEEKLY
FROM ONLY **£36.13⁺**
ONLY **£7,169.00**



PROHEAT AUTOMATIC IGNITION HEATERS WITH FIXED VENTS AND NO BUILT IN TANK

PROHEAT 30
WITH FLUE KIT
594 77 2920

WEEKLY
FROM ONLY **£11.95⁺**
ONLY **£2,372.00**

PROHEAT 40
WITH FLUE KIT
594 77 2930

WEEKLY
FROM ONLY **£13.04⁺**
ONLY **£2,588.00**

PROHEAT 60
WITH FLUE KIT
594 77 2940

WEEKLY
FROM ONLY **£14.68⁺**
ONLY **£2,913.00**

PROHEAT 80
WITH FLUE KIT
594 77 0900

WEEKLY
FROM ONLY **£16.10⁺**
ONLY **£3,195.00**

FLOWMATIC PNEUMATIC PUMP SYSTEM 594 77 1620

For bulk storage with top outlets and/or distances above 15m

ONLY **£575.00**

DIGITAL THERMOSTAT TIMER FOR SB HEATERS 594 77 2490

Energy management computer for extremely precise space heating control

ONLY **£199.00**

*Finance example typically based on a 5 year lease purchase agreement. Finance subject to status, full terms and conditions available on request. Other finance options available. All prices exclude VAT at 20%. Price, availability and specification may change without prior notice. Warranty subject to manufacturers terms and conditions of use. Errors and omissions excluded. Offers valid until 31st December 2017. Prices correct at time of going to press: October 2017.

HITON UNIVERSAL OIL HEATERS

Floorstanding, manual ignition, virtually soot-free oil-burning* heaters. Suitable for general automotive workshops, the HP105 produces radiant heat, whilst the other models, being fan assisted, produce warm air heating.

Supplied complete with a flue kit and setup instructions, these heaters do not require specialist engineer installation. Enclosed-flame setup ensures efficient combustion.

**EXCLUSIVE
3 YEAR WARRANTY**

**SUPPLIED WITH
STANDARD FLUE KIT**

HP105

594 77 2280

- 51,182 - 75,067 BTU Heat Output
- 1.25 - 1.85 kg/hr Fuel Consumption
- 50 Litre Tank Capacity
- 420m³ Approx Heating Area
- Without top fan produces radiant heat only



ONLY **£899.00**



HP115

594 77 2290

- 51,182 - 75,067 BTU Output
- 1.25 - 1.85 kg/hr Fuel Consumption
- 50 Litre Tank Capacity
- 420m³ Approx Heating Area
- With top fan to distribute the heat



ONLY **£999.00**



HP125

594 77 2310

- 72,000 - 102,420 BTU/hr Output
- 1.8 - 2.9kg/hr Fuel Consumption
- 50 Litre Tank Capacity
- 668m³ Approx Heating Area



WEEKLY FROM ONLY **£5.54⁺**
ONLY **£1,099.00**

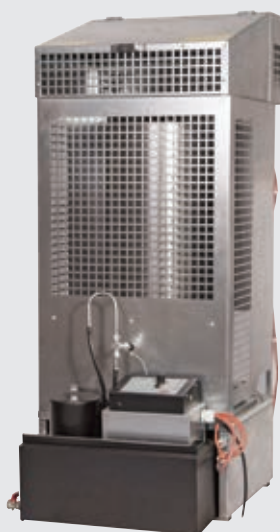

HP145

594 77 2030

- 102,420 - 143,406 BTU Heat Output
- 2.55-3.57kg/hr Fuel Consumption
- 50 Litre Tank Capacity
- 935m³ Approx Heating Area



WEEKLY FROM ONLY **£8.54⁺**
ONLY **£1,695.00**

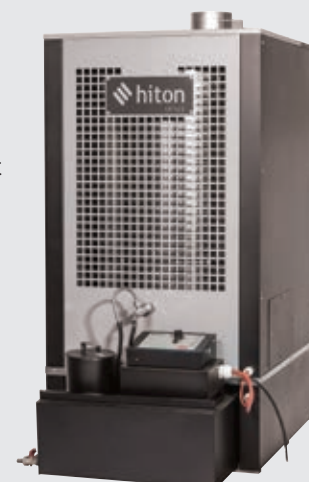

FLUE BOOSTER

The Heater Booster simply slots between the heater and the flue and increases the heater's output by up to 10% utilising the heat that would normally be lost through the flue.



FOR HP105, 115, 125 AND 135

594 77 2320

ONLY **£249.00**

FOR HP145

594 77 2330

ONLY **£249.00**

*Heaters operating on Used Oil require a relevant permit under Schedule 13A of the Environmental Permitting Guidance (EPR). There will be requirements placed on emissions monitoring and operational control procedures.

*Finance example typically based on a 5 year lease purchase agreement. Finance subject to status, full terms and conditions available on request. Other finance options available. All prices exclude VAT at 20%. Price, availability and specification may change without prior notice. Warranty subject to manufacturers terms and conditions of use. Errors and omissions excluded. Offers valid until 31st December 2017. Prices correct at time of going to press: October 2017.

One call for complete peace of mind – Workshop Solutions

Your business is your livelihood. We understand that and we care. At Workshop Solutions we provide you with all the equipment; service, repair and maintenance programmes; assistance with health & safety procedures and project planning skills you need all in one place. We are the equipment and service provider of choice to many motor manufacturer groups, independent garages and bodyshops nationwide. From a new compressor to an MOT bay, comprehensive building works to aftersales servicing and maintenance, Workshop Solutions manages the whole process, ensuring a smooth, hassle-free, one-stop service that is delivered on time and on budget.



The Latest Technology from the Best Brands

We aim to provide you with the tools, equipment and service that match both your personal expectations and your business requirements.



Waste Management – Keeping you fully compliant and stress free



Our panel of finance houses can spread the cost tax-efficiently



Health & Safety – Safeguarding your people and your business



From preventative maintenance plans to emergency call-outs

Please contact our Equipment Service & Maintenance team on **01827 838477** to arrange an initial free, no obligation consultation.

Buy or Lease with Confidence

All of us at Workshop Solution aim to provide you with the tools, equipment and service that match both your personal expectations and your business requirements.

We're also with you for the long haul, understanding that delivering true value comes from developing good long-term relationships.

Put simply, if we can ensure that every pound you spend on garage equipment has the potential to bring you the maximum returns then you might think of us next time you're in the market for equipment.

That's why we only use suppliers who can offer a comprehensive warranty service and update backup for the life of the equipment.

We will also arrange demonstrations wherever possible and offer advice on the best products and services to suit your business.

OUR PROMISE:

- We make sure the equipment you buy is right for you.
- We only put products in front of you that we know are fully supported in the UK by the manufacturer.
- We provide you with the best possible service now and in the future.

NO HASSLE WARRANTY

BEST PRICE PROMISE

THE ADVANTAGES OF LEASING

1. PAYMENTS ARE TAX DEDUCTIBLE

Lease payments are classed as a rental or business expense and therefore can be offset against profits made over the financial year.

2. ABILITY TO HAVE THE BEST PRODUCT AVAILABLE

Choosing the cheaper option can prove to be a false economy as that equipment often needs replacing sooner than the best quality product available to you.

3. PAY AS YOU EARN

Most equipment either saves you money or makes you money, therefore the equipment pays for the lease as it works for you.

4. PAYMENTS ARE FIXED

Fixed payments make it easier for you to budget and plan your major purchases.

5. IMPROVES CASH FLOW AND PROTECTS OTHER CREDIT LINES

By leasing equipment you can protect your cash and other lines of credit.

*Finance example typically based on a 5 year lease purchase agreement. Finance subject to status, full terms and conditions available on request. Other finance options available. All prices exclude VAT at 20%. Price, availability and specification may change without prior notice. Warranty subject to manufacturers terms and conditions of use. Errors and omissions excluded. Offers valid until 31st December 2017. Prices correct at time of going to press: October 2017.



SERVICING YOUR AIR CONDITIONING MACHINE brings benefits at every stage of operation

REFRIGERANT RECOVERY

The oil level and performance of the internal compressor is checked to ensure fast recovery, efficient operation and component reliability

REFRIGERANT RECYCLING

The machine filter is changed to ensure the recycled refrigerant meets the applicable S.A.E. standard (J2099)

SYSTEM EVACUATION

Vacuum pump performance and operation is checked, the oil is changed to ensure the machine is able to rapidly achieve a deep vacuum to fully de-hydrate the vehicle A/C system and help prevent internal corrosion.

REFRIGERANT RECHARGING

Charging accuracy is re-calibrated (to +/- 25 gms), using a certified calibration weight, so your customer's A/C systems are always charged correctly (for optimum system performance)

REFRIGERANT LEAKAGE

Additional checks during the service procedure ensure there is no refrigerant leakage at any stage of the machine's operation. Refrigerant loss to atmosphere is prosecutable under the Environmental Protection Act (1990).

QUALITY MANAGEMENT

Servicing of garage equipment may be required to comply with the terms of some ISO Quality Management Systems e.g. PAS125.

P.U.W.E.R. 1998

Provision and Use of Workshop Equipment Regulation 1998 confers a duty to ensure all equipment provided by your business is well maintained and safe to use.



To confirm if we can service
your Air Conditioning Machine
call your local branch

