

ALL-NEW JAGUAR XF



THE ART OF PERFORMANCE





BY APPOINTMENT TO
HM THE QUEEN
MANUFACTURERS OF
MOTOR VEHICLES
JAGUAR LAND ROVER LIMITED
COVENTRY



BY APPOINTMENT TO
HRH THE DUKE OF EDINBURGH
MANUFACTURERS OF
MOTOR VEHICLES
JAGUAR LAND ROVER LIMITED
COVENTRY



BY APPOINTMENT TO
HRH THE PRINCE OF WALES
MANUFACTURERS OF
MOTOR VEHICLES
JAGUAR LAND ROVER LIMITED
COVENTRY



JAGUAR

THE ART OF PERFORMANCE

Every day we push performance to its limit. Our performance. Our cars' performance.
We innovate, we engineer, we design. We master rules and then break them.
Only to push further. Past the limits of convention. This is when performance becomes art.

Jaguar. The Art of Performance.





CONTENTS

INTRODUCTION

The Concept of XF	07
XF - The Facts	08

DESIGN

Exterior Principles	10
Exterior Aerodynamics	12
Interior	17
Interior Space	19

PERFORMANCE

Engines	20
Automatic Transmission	22
Advanced Aerodynamics	24
Lightweight Aluminium Architecture	27
Chassis and Suspension	28
Advanced Driving Dynamics	31

DRIVING TECHNOLOGY

All Surface Progress Control	32
Torque Vectoring	34
Stability and Control	37
Head-Up Display	39

INFOTAINMENT

InControl Technologies	40
InControl Touch	43
InControl Touch Pro	45
Audio	46

SAFETY AND EFFICIENCY

Advanced Driver Assistance	48
Efficient Technologies	50

PERSONALISATION

XF - Your Choice	52
Choose your Engine	54
Choose your Model	56
Choose your Options	58
Choose your Colour	64
Choose your Wheels	66
Choose your Interior	68
Choose your Jaguar Accessories	86
Technical Specifications	88
Dimensions	90

JAGUAR WORLD

Jaguar Experience	92
The World of Jaguar	94
Glossary and Legal Information	96



Scan to find out more about the all-new Jaguar XF.

VEHICLE SHOWN: XF PRESTIGE IN RHODIUM SILVER WITH OPTIONAL 19" RAZOR ALLOY WHEELS

VEHICLES SHOWN ARE FROM THE JAGUAR GLOBAL RANGE. SPECIFICATIONS, OPTIONS AND AVAILABILITY WILL VARY BETWEEN MARKETS AND SHOULD BE VERIFIED WITH YOUR LOCAL JAGUAR RETAILER





INTRODUCTION

THE CONCEPT OF XF

XF is all-new. Building on the success of Jaguar's most award-winning car ever. Possessing an unrivalled combination of style and substance. Delivering an utterly seductive blend of design, dynamics and refinement to create a car that offers both excitement and efficiency. All enhanced by state-of-the-art technologies that keep you safe, connected and entertained.

XF sits in the Jaguar saloon range between XE's taut athleticism and the supreme luxury of XJ. The fusion of these outstanding Jaguar attributes is what creates XF - the most dynamic, premium business saloon of its generation.

VEHICLE SHOWN: XF S IN GLACIER WHITE WITH 20" LABYRINTH ALLOY WHEELS, OPTIONAL LED HEADLIGHTS, BLACK PACK AND SUNROOF

XF - THE FACTS

An outstanding combination of advanced engineering, the latest technology and contemporary design sets XF apart.

ADVANCED AERODYNAMICS

XF is capable of achieving a drag coefficient of just Cd. 0.29, one of the lowest in its class. Even the underside of the car is aerodynamically designed to be as smooth as possible, while apertures in the front bumper optimise airflow through the wheel arches. XF cuts through the air, reducing wind noise for enhanced refinement and improved efficiency.

BREADTH OF PERFORMANCE

The XF range delivers a new generation of performance engines. From fuel economy as low as 7.5 l/100km, to a top speed limited to 250km/h and 0-100km/h in 5.3 seconds - there is an XF for every driver.

CRAFTSMANSHIP AND SPACE

Contemporary craftsmanship and a beautiful, luxurious interior with the space to stretch out and enjoy every journey. Compared with the previous XF rear knee room has increased by 24mm, making it best in class. Rear legroom has increased by 15mm and rear headroom has risen by up to 27mm**, all adding up to greater comfort and wellbeing for passengers.

**Applicable to XFs not fitted with optional sunroof.

Some features described here are optional and market dependent.

VEHICLE SHOWN: XF S IN GLACIER WHITE WITH 20" LABYRINTH ALLOY WHEELS, OPTIONAL LED HEADLIGHTS, BLACK PACK, SUNROOF AND PRIVACY GLASS

LIGHTWEIGHT ALUMINIUM ARCHITECTURE

Jaguar's Lightweight Aluminium Architecture helps to make XF lighter, stronger and 28 percent stiffer than the previous XF. It is up to 190kg lighter than its predecessor, improving handling, performance and efficiency.

ADDED INTELLIGENCE

Innovative technologies make every drive easier and safer. XF offers optional adaptive LED headlights, Head-Up Display, Adaptive Cruise Control with Queue Assist and Advanced Parking Assist.

ADVANCED DRIVETRAIN TECHNOLOGY

Combine performance with the rewards of improved fuel efficiency. Jaguar's 8-speed automatic transmission offers lightning-fast gearshifts and automatically adapts to suit your driving style - from economical to sporting.

ALWAYS CONNECTED

InControl Touch is XF's all new multimedia system which features a contemporary and fresh graphical design. The intuitive touch and swipe controls, or optional voice input, provide you with full control over a wealth of features including audio, climate control and satellite navigation. InControl Touch is your personal command centre.





DESIGN EXTERIOR PRINCIPLES



DESIGN
PURITY

ADAPTIVE
LED HEADLIGHTS

VEHICLE SHOWN RIGHT: XF S IN GLACIER WHITE WITH 20" LABYRINTH ALLOY WHEELS,
OPTIONAL SUNROOF, OPTIONAL LED HEADLIGHTS, BLACK PACK AND SURROUND CAMERA

"It's about paring it down to the bare essentials. Good designers have always said less is more."

Ian Callum, Jaguar Design Director.

XF demonstrates the Jaguar principles of design purity. Strong lines radiate dynamic character and enhance its capabilities - be it improving aerodynamics, visibility, stability or safety. XF is available with adaptive LED headlights* featuring Jaguar signature J-Blade Daytime Running Lights to give XF a striking on-road presence. The quality of LED light is close to daylight, helping your eyes to distinguish objects more easily and reducing fatigue at night.

*Optional feature, Xenon headlights are also available depending on the model chosen.



EXTERIOR AERODYNAMICS



At the rear, XF's tail lights feature a distinctive, Jaguar F-TYPE inspired, double roundel and intersecting horizontal detail. The LED brake lights are not only brighter than halogen bulbs, they use less energy - contributing to XF's overall drive for greater efficiency. LEDs also illuminate faster - so following drivers can react more quickly to XF's braking. Within the tail lights is a pinstripe graphic - one of XF's many exquisite finishing touches.

XF's sweeping exterior design is naturally aerodynamic. Its advanced form enhances handling, dynamics and refinement. Even the boot lid's height and pitch, as well as its overall curvature and subtle spoiler, are designed to reduce drag and increase downforce. For example, the body generates as much as 50kg of extra downforce at 160km/h for greater stability and helps XF maintain its connection with the road.

VEHICLE SHOWN: XF PRESTIGE IN RHODIUM SILVER WITH 19" RAZOR ALLOY WHEELS











Darkness
Oliver Dabry
Darkness
4/12

140 180 200 220 240 260 280 300
0
60 80 100 120

3 4 5
P
1 2

HOME 22:10

Darkness
Oliver Dabry
33°C
Outside 15°C
23°C

Hi's Phone
 Vodafone
High St
Kensington

SYNC

MAX A/C

MAX A/C A/C

STOP
ENGINE

P R N D S



INTERIOR



**DRAMATIC START-UP
SEQUENCE**

**CONTEMPORARY
CRAFTSMANSHIP**

Open XF's door and the Start button entices you inside. Pulsing with a heartbeat it creates an emotional connection between driver and machine. Its 72 per minute double beat is the same as a jaguar cat at rest. XF is poised, ready for action. Now push the Start button. The car awakens and its mood lighting illuminates. With perfect choreography, air vents rotate open, the JaguarDrive Selector rises smoothly, the engine growls - all inspiring you to anticipate the drive ahead.

XF's interior offers outstanding comfort, a sense of wellbeing and a wealth of choice. The number of switches and buttons has been reduced to keep the look clean and tidy, as well as making them easy to use. Whichever XF interior combination you choose, materials used are always of the highest quality. Leather and finishes are selected with the greatest care to ensure that, inside XF, everything is luxurious to the touch. Whether you prefer aluminium, carbon fibre, or wood veneer finishes to complement the beautiful selection of leathers, your XF will always look and feel just right.

INTERIOR SHOWN LEFT AND PREVIOUS PAGE: XF S FEATURING LIGHT OYSTER/JET SEAT WITH JET UPPER FACIA WITH CONTRAST STITCH, JET CARPET AND JET HEADLINING. OPTIONAL EQUIPMENT FITTED



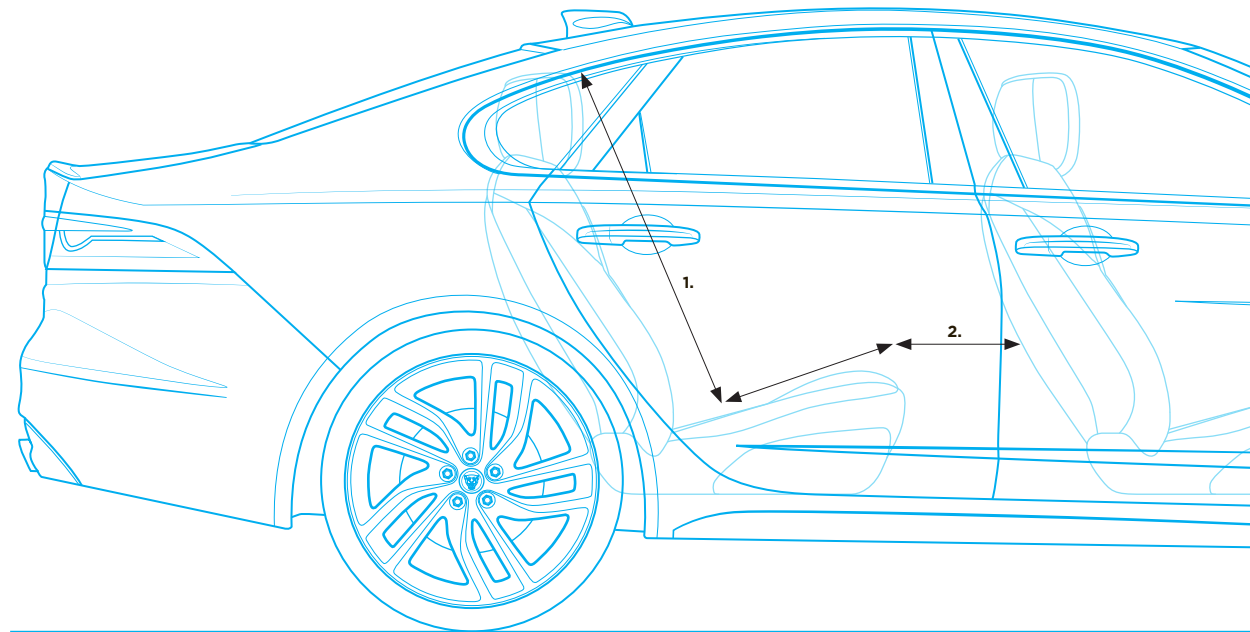

1. Headroom 970mm 2. Knee room 87mm

INTERIOR SPACE

CLASS-LEADING REAR KNEE ROOM

The rear of XF's cabin is a destination of luxury, choice and space. Compared with the previous XF, rear knee room has increased by 24mm, making it best in class. Rear legroom has increased by 15mm and rear headroom has risen by up to 27mm*, all adding up to greater comfort and wellbeing for passengers. Building on the drama of its predecessor's interior, mood lighting also enhances XF's atmosphere. Opt for Configurable Interior Mood Lighting and you'll have a choice of ten interior colours. The choice continues with optional four-zone air conditioning, giving individual passengers the opportunity to set their own temperature and airflow. Keeping your car comfortable regardless of the conditions outside, XF's air conditioning system has undergone punishing real world tests in ambient temperatures ranging from 50°C to -30°C. XF's interior is flexible. You can choose the 40:20:40 seating configuration for increased volume and versatility. Whatever you want, whenever you need it, XF offers it all.

*Applicable to XFs not fitted with optional sunroof.

INTERIOR SHOWN: XF S FEATURING LIGHT OYSTER/JET SEAT WITH CONTRAST STITCH, JET CARPET AND JET HEADLINING

PERFORMANCE ENGINES



INGENIUM ENGINES

STOP/START TECHNOLOGY*

XF offers a choice of refined, efficient diesel* or petrol engines – all delivering a dynamic driving experience and responsive Jaguar performance. XF's engines are equipped with Stop/Start technology* and smart regenerative charging – harvesting kinetic energy from braking to charge the battery – for maximum economy, especially during urban driving.



DIESEL* ENGINES FROM

114g/km CO₂

XF is offered with two diesel engines. An engine from the new Ingenium range is available: the 2.0 litre i4 turbocharged diesel (180PS). Ingenium engines from this advanced all-aluminium range are typically 20kg lighter than the equivalent engines from the previous generation – making them more efficient from the outset. They offer effortless performance, immediate high torque delivery and refinement with lower fuel consumption and CO₂ emissions. Also available is the acclaimed 3.0 litre V6 diesel engine. For XF's performance requirements, power has been increased to 300PS with class-leading torque of 700Nm for greater responsiveness, while fuel economy has been improved by up to nine percent.

*Market dependent

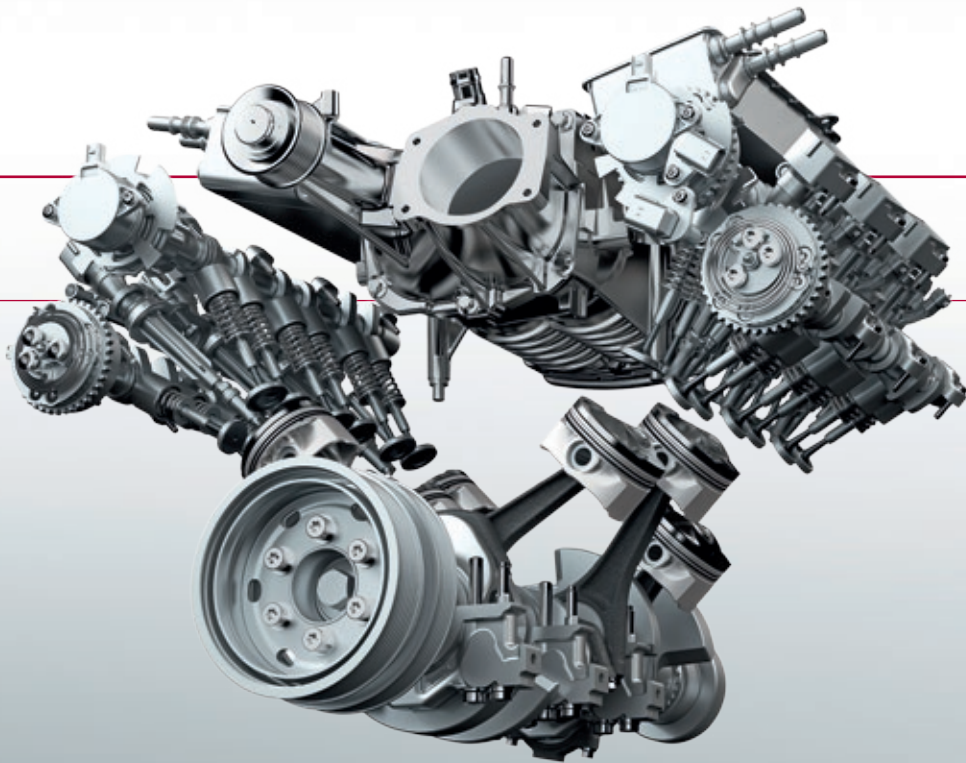

PETROL ENGINES UP TO

0-100km/h in 5.3 sec

XF's petrol engines offer power and responsiveness throughout the rev range, while improving efficiency. The 2.0 litre 240PS 4-cylinder turbocharged petrol engine achieves '6-cylinder engine' levels of performance and refinement, from a more compact and economical structure. Shared with Jaguar F-TYPE, the 3.0 litre V6 supercharged petrol engine is available in both 340PS and 380PS versions. The new 380PS engine is capable of 0-100km/h in 5.3 seconds. These all-aluminium engines deliver instant access to high levels of torque at all engine speeds, and a unique soundtrack.

AUTOMATIC TRANSMISSION

EIGHT-SPEED AUTOMATIC TRANSMISSION

XF's automatic transmission is highly responsive, smooth and efficient. It delivers rapid shifting for effortless acceleration and overtaking. The intelligent, adaptive system subtly changes the way the throttle delivers power, as well as gearshift patterns, to suit each particular driving circumstance. The unique JaguarDrive Control offers even quicker shifts and sportier kickdown in Dynamic Mode, and earlier up-shifts in Eco Mode. With the automatic transmission the driver can opt to manually control gearshifts, via steering wheel paddles, at the touch of a finger.



ADVANCED AERODYNAMICS



LOW DRAG

| Cd. 0.29

XF's form has been rigorously optimised for aerodynamic efficiency and stability at motorway speeds. XF cuts through the air – reducing fuel consumption and lowering emissions. Every element exploits the exterior's maximum aerodynamic potential while preserving XF's stunning proportions. Vertical apertures in the front bumper outer edges channel air through vents in the wheel arches and out over the front wheels. The airflow then passes along XF's sides where the doors have a flatter cross sectional profile to minimise air pressure differences and contribute further to reduced drag. Even the extensive under body protection is designed to make XF as efficient, economical and refined as possible.

VEHICLE SHOWN: XF PORTFOLIO IN BLACK BERRY WITH 20" MATRIX ALLOY WHEELS AND OPTIONAL LED HEADLIGHTS



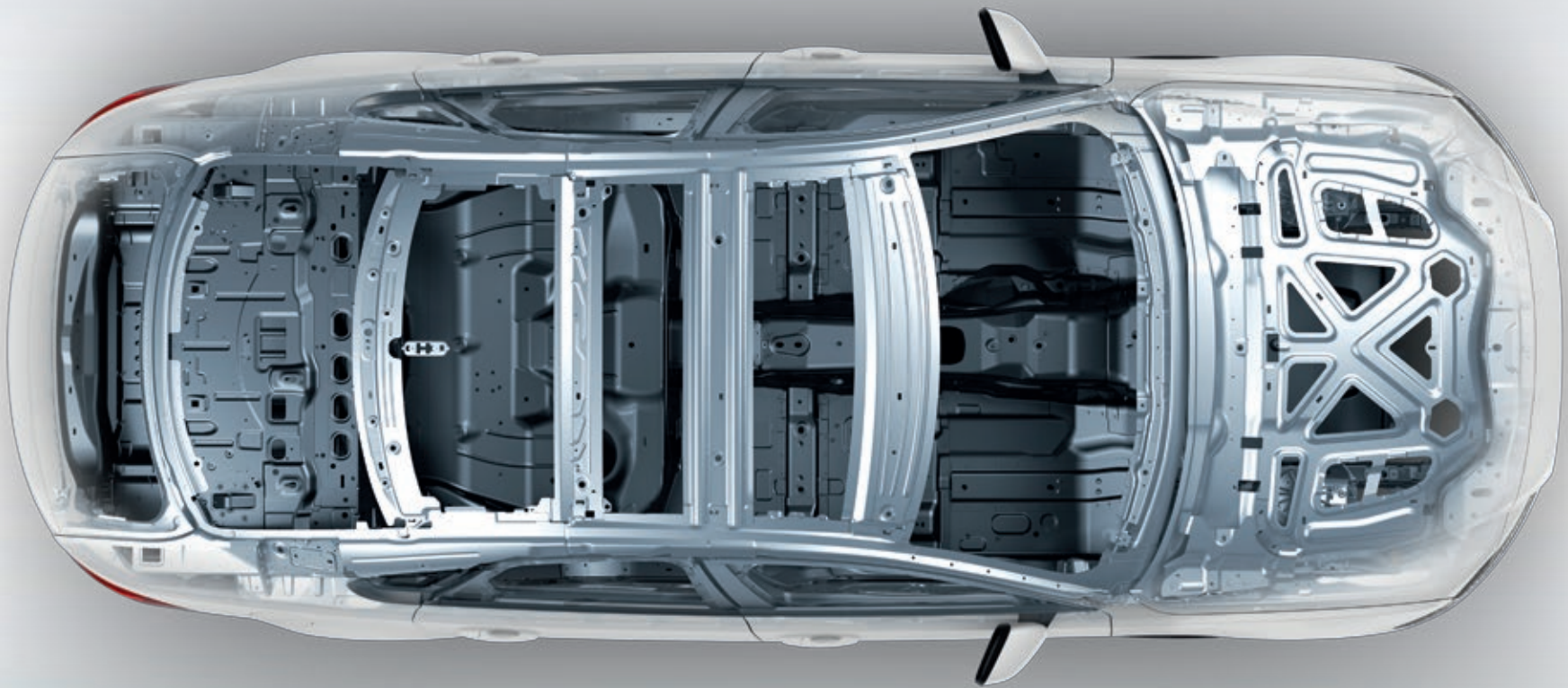

LIGHTWEIGHT ALUMINIUM ARCHITECTURE

 **STRONG** | **RIGID** | **75% ALUMINIUM**

Jaguar has been at the forefront of aluminium car construction for more than a decade. Our latest innovation is Lightweight Aluminium Architecture, which is significantly lighter, stronger and 28 percent stiffer than the structure used in XF's predecessor. Aluminium has also been used to form the body sides, bonnet and front wings of XF. Lightweight aluminium panels are bonded together with a super-strong adhesive, then punched with zinc-coated, boron steel rivets that compress the adhesive to form an airtight bond and a phenomenally strong, rigid structure. This cutting edge process, coupled with the Lightweight Aluminium Architecture, contributes towards weight savings of up to 190kg over the XF it replaces.

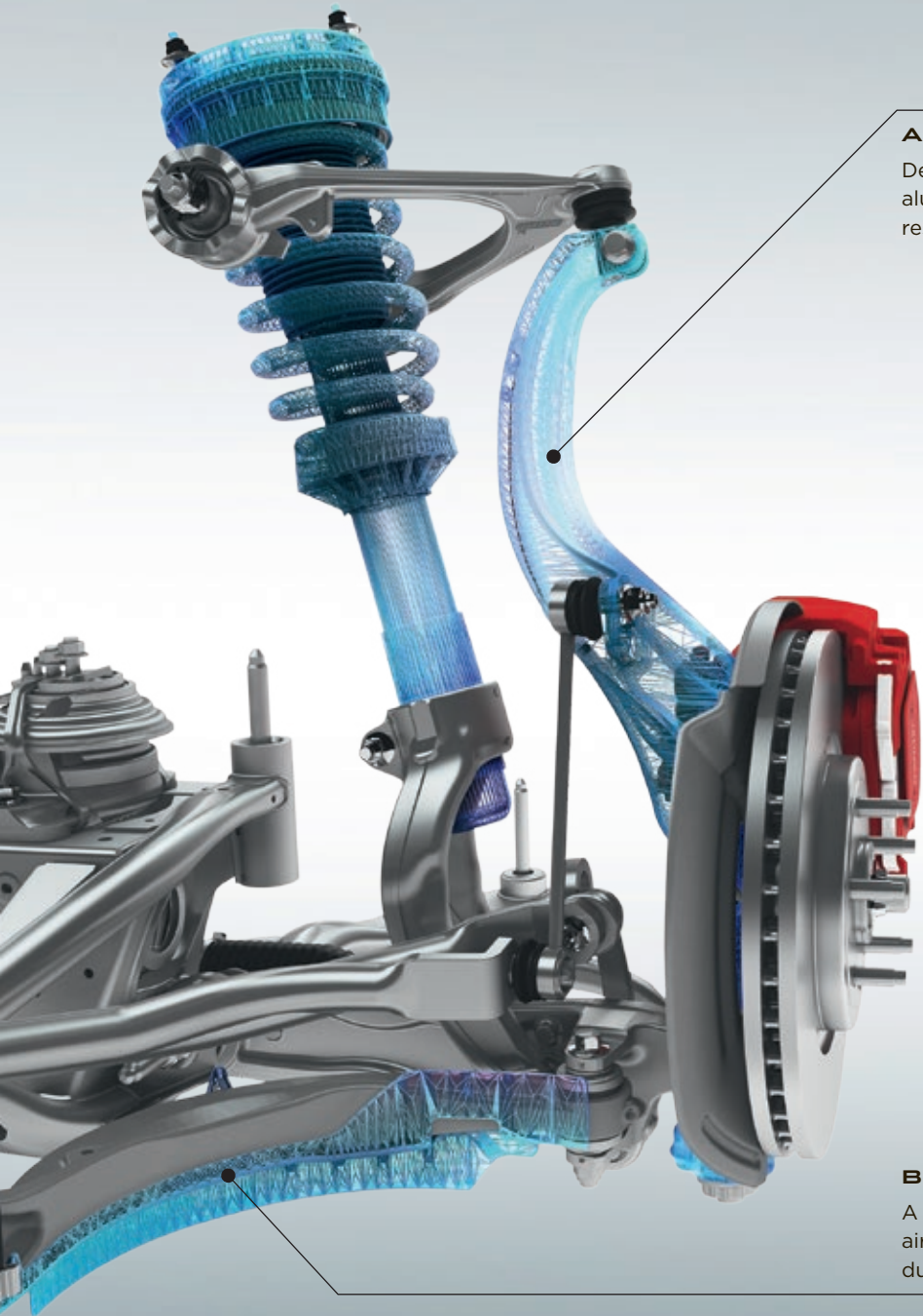

ALUMINIUM FRONT KNUCKLE

Designed to optimise stiffness and strength, the lightweight aluminium front knuckle helps improve XF's agility, responsiveness and refinement for sports car-like control.

CHASSIS AND SUSPENSION



UNIQUE SUSPENSION
TECHNOLOGY

COMFORTABLE
AND DYNAMIC

XF responds with agility and performs with dynamism while always maintaining ride comfort – it's a unique balance that makes it a Jaguar. The ideal foundation for these driving dynamics is XF's light, yet exceptionally strong and stiff, Lightweight Aluminium Architecture with its near 50:50 weight distribution.

The sophisticated front and rear suspension systems complete a chassis that achieves a superb combination of sportiness and refinement. Advanced damper technologies – both passive or adaptive – improve ride quality still further and extend XF's breadth of dynamic capability. The suspension's control, agility and feedback give XF the spirit of a sports car.

BRAKE SCOOP

A glass-filled polypropylene brake scoop channels air onto the brakes for enhanced brake performance during enthusiastic driving.

INTEGRAL LINK REAR SUSPENSION

Integral Link suspension allows XF to realise a perfect combination of a refined, luxurious ride and sharp, responsive handling. The system, the benchmark for this class of car, separates and independently manages the lateral, longitudinal and vertical forces acting on the suspension for enhanced control and comfort. Many components are forged or hollow-cast in aluminium – the optimum production techniques for strong, lightweight suspension.

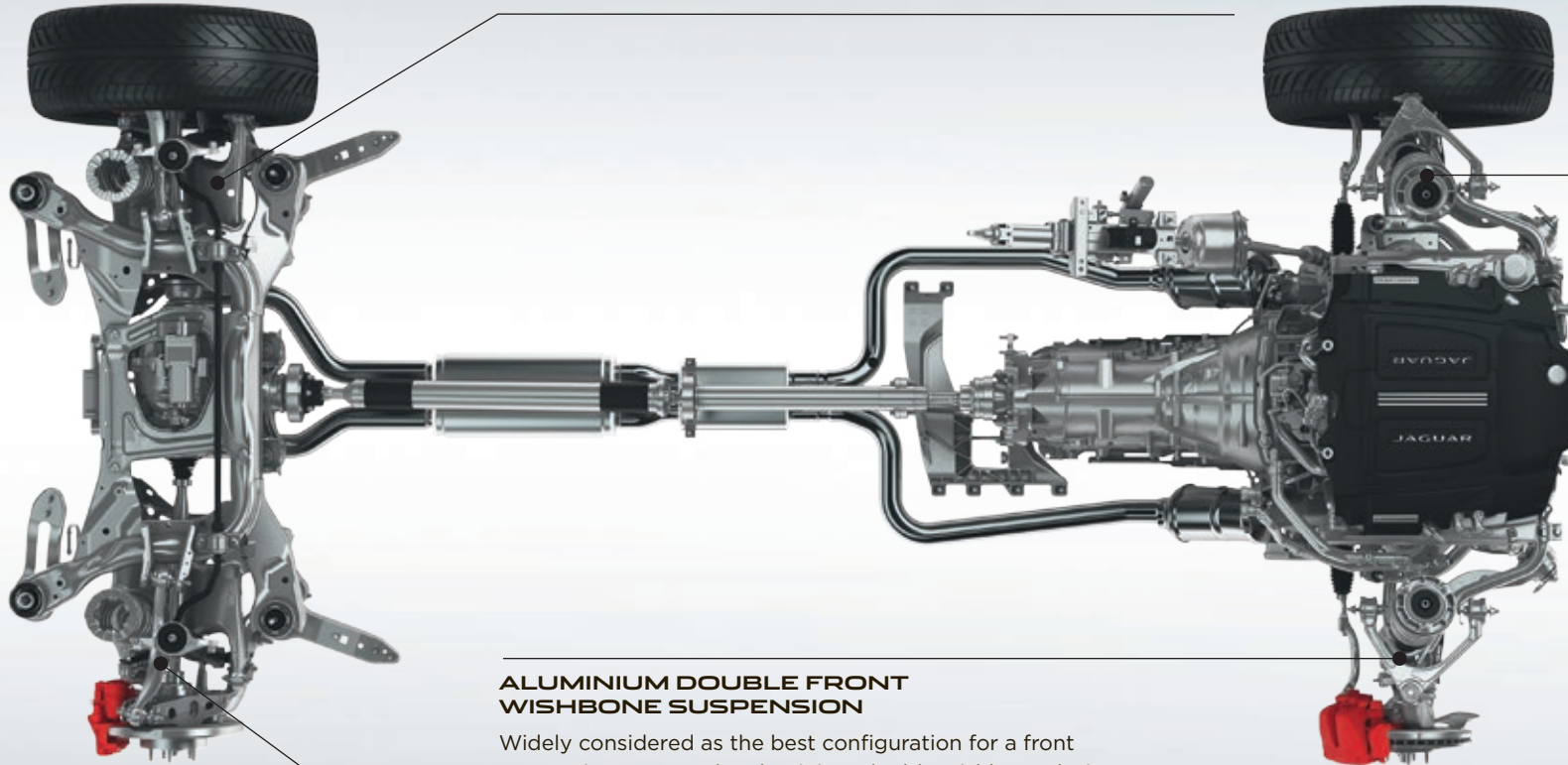

**ADAPTIVE
DYNAMICS**

ALUMINIUM DOUBLE FRONT WISHBONE SUSPENSION

Widely considered as the best configuration for a front suspension system, the aluminium double wishbone design is modelled closely on F-TYPE's for precise handling and steering response.

ADAPTIVE DYNAMICS

The optional Adaptive Dynamics system delivers both precise dynamics and a supple, luxurious ride by monitoring wheel position and body movements. The Active Dampers adjust the suspension to provide the optimum balance between comfort and refinement at all times.



ADVANCED DRIVING DYNAMICS



MAXIMISING AGILITY

CONTINUOUSLY ADAPTING

ADAPTIVE DYNAMICS

Whether you're accelerating on the motorway, cornering on country roads or navigating around town, optional Adaptive Dynamics modifies XF's response to match the conditions and your driving style. It analyses acceleration, cornering, throttle and brake pedal activity, as well as kick down activation. Steering and body movement are also analysed up to 500 times a second. Using this information, electronically controlled adaptive dampers then constantly adjust to optimise the suspension settings and maintain XF's poise and comfort.

ELECTRIC POWER ASSISTED STEERING

XF's next generation Electric Power Assisted Steering (EPAS) offers outstanding feedback, control and immediate power assistance. It is active on demand - saving power for when you really need it, as well as saving fuel. Allowing sophisticated computer management to adapt the levels of steering support, EPAS gives you fine control at speed and comprehensive assistance during slow manoeuvring. It also enables advanced optional safety features such as Lane Keep Assist and Park Assist.

CONFIGURABLE DYNAMICS

Bringing technology from F-TYPE, the optional Configurable Dynamics* system allows you to set up XF's dynamics for suspension, throttle mapping, gearbox shift points and steering to suit your performance driving needs. It is activated when Dynamic Mode is selected in JaguarDrive Control. Dynamic Mode enlivens XF's sporting character. It sharpens throttle response, increases steering weighting and performs gearshifts more quickly and at higher engine speeds. Even more visual drama is brought to the cabin with the instrument dials and optional Configurable Mood Lighting taking on a red glow. Dynamic Mode enhances your connection with XF's sports car performance.

*Configurable Dynamics is only available with cars fitted with V6 engines and InControl Touch.

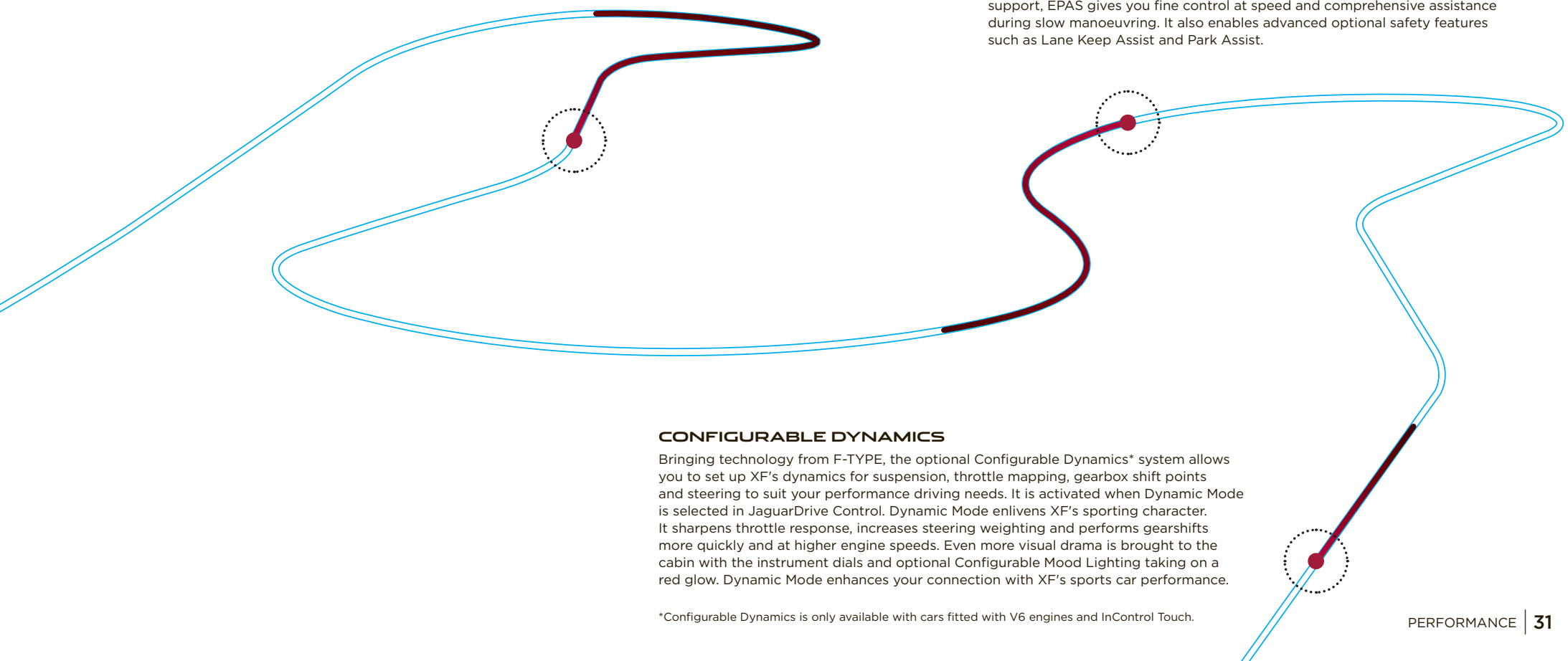

DRIVING TECHNOLOGY

ALL SURFACE PROGRESS CONTROL



ADDED DRIVER CONFIDENCE

LOW SPEED CRUISE CONTROL

Unique in this class of car, Jaguar's All Surface Progress Control (ASPC) technology is a low speed cruise control that helps XF to cope with low traction situations. ASPC allows the driver to concentrate on steering the vehicle. Once activated, you use the cruise control buttons to set a 'target' speed of between 3.6km/h and 30km/h. The system then works to achieve and maintain that speed while exerting optimum traction control.

ASPC is standard on all engines fitted with automatic transmissions and gives XF drivers added confidence over slippery, loose or icy surfaces, undulating terrain and even while descending a difficult incline. It helps make XF easy to drive in challenging conditions. ASPC also has a pull-away function allowing XF to progress from rest on slippery surfaces and ascending gradients, as well as a hill descent function that controls vehicle speed on steeper inclines.

With any given set of tyres, ASPC can accomplish comparable levels of traction to that achievable by an expert driver. Fitting All Season or Winter tyres to XF can improve capability on slippery surfaces.

GRAVEL



WET GRASS



SNOW/ICE



WET ROAD

TORQUE VECTORING APPLIES BRAKE PRESSURE TO SLOW THE INSIDE FRONT AND INSIDE REAR WHEELS INDEPENDENTLY.

TORQUE VECTORING

MAXIMISED CORNERING CAPABILITY

XF's Torque Vectoring maximises capability through even the tightest corners. Torque Vectoring technology provides controlled independent braking on the individual inside front and rear wheels to add to the turning forces acting on the car. In most conditions more braking pressure is applied to the rear inside wheel as this supports the most increased cornering capability, while the front inside wheel is braked for greater effectiveness and refinement. The result is reduced understeer for sharper turning and more consistent road holding. Torque Vectoring delivers increased sports car-like agility and added driver confidence.

POWER IS SUSTAINED TO MAINTAIN CONSTANT SPEED OF OUTER WHEELS.

ADDITIONAL ROTATIONAL FORCE APPLIED AROUND VEHICLE'S AXIS.

VEHICLE SHOWN: XF PRESTIGE IN RHODIUM SILVER WITH 19" RAZOR ALLOY WHEELS AND OPTIONAL BI-FUNCTION HID XENON HEADLIGHTS



JAGUAR

473 CAS

XF

20d

STABILITY AND CONTROL



DYNAMIC STABILITY CONTROL

ENGINE DRAG TORQUE CONTROL

Jaguar's Stability Systems keep XF safely balanced whether you're driving enthusiastically or simply want the assurance of a car that will remain stable in challenging conditions.

Dynamic Stability Control (DSC) monitors XF's dynamic behaviour, intervening to maximise vehicle stability and optimising available grip. DSC reduces engine torque and applies braking to the appropriate wheels to correct the car's direction of travel by counteracting understeer or oversteer. XF's DSC system has enhanced understeer control to reduce speed and regain control more effectively.

Engine Drag Torque Control (EDC) mitigates the chance of wheel lock-up caused by strong engine braking in slippery conditions. It acts by briefly increasing torque to the wheels as appropriate.

BRAKING APPLIED TO APPROPRIATE WHEELS TO COUNTERACT UNDERSTEER/OVERSTEER

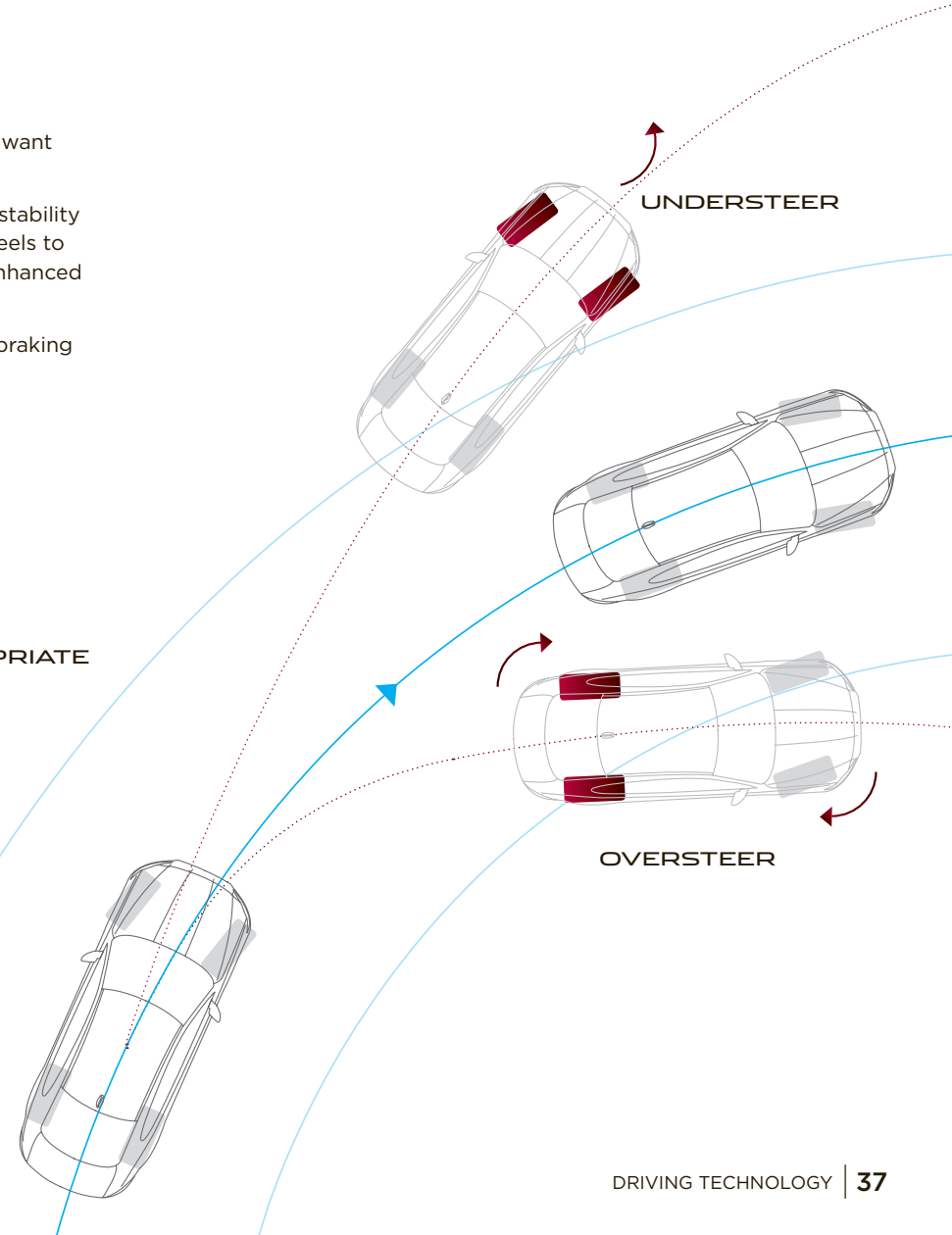



HEAD-UP DISPLAY

> HEAD-UP DISPLAY WITH LASER TECHNOLOGY

The optional Head-Up Display (HUD) with laser technology projects key information onto the windscreen. Remaining clear even in direct sunlight, the crisp, bright image can display vehicle speed, navigation, cruise control notifications and Forward Alert data. This technology helps you minimise time spent looking down at the instrument cluster and can help you maintain continuous awareness of the car's speed.

ADAPTIVE CRUISE CONTROL WITH QUEUE ASSIST

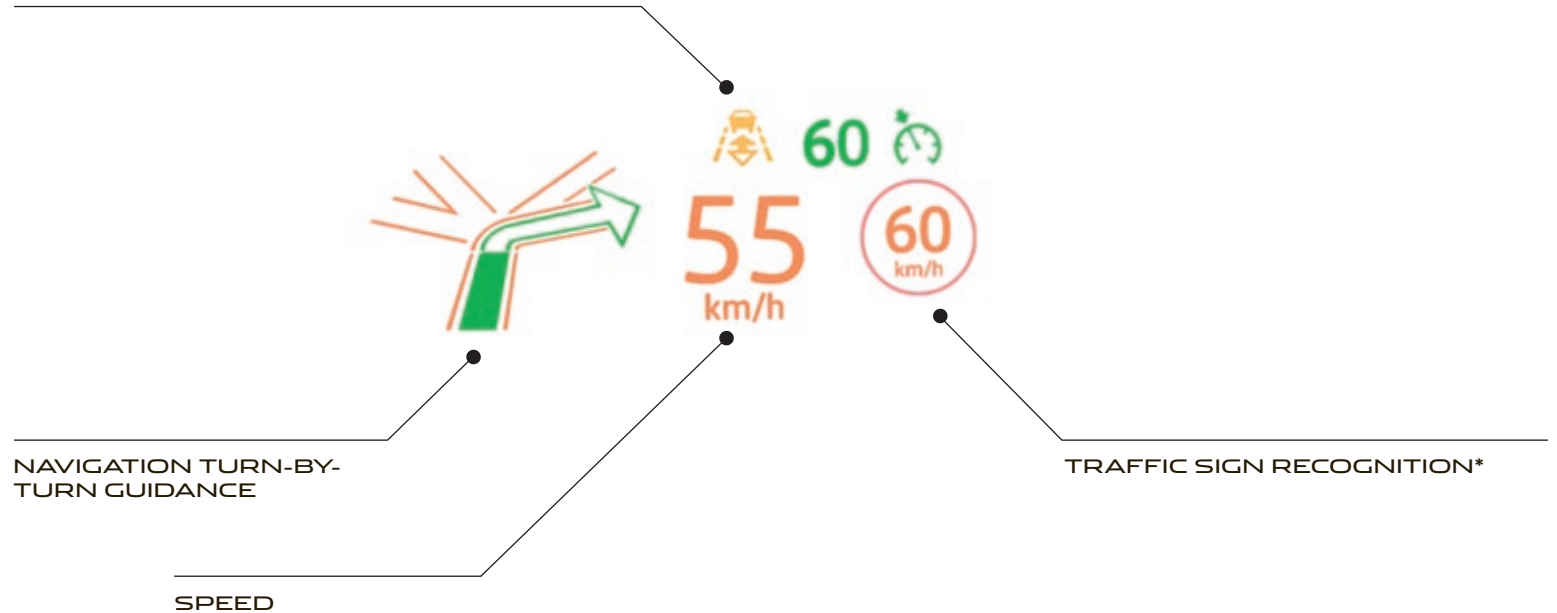

*Market dependent.

INFOTAINMENT INCONTROL TECHNOLOGIES

 INCONTROL TOUCH | INCONTROL TOUCH PRO

Choose from two InControl infotainment systems: InControl Touch, available as standard, or upgrade to InControl Touch Pro*.

*As we systematically introduce InControl, specific features, options and its availability remain market dependent. Third Party programmes or applications may require an end user licence from the supplier.



INCONTROL TOUCH



STANDARD ON EVERY XF

- 8 inch Touch-screen
- 5 inch instrument panel display with analogue dials
- Jaguar Sound System (80W)
- FM Radio
- iPod, USB, Bluetooth® and AUX connections

ADDITIONAL OPTIONS

- Meridian Sound System (380W)
- InControl Touch SD Navigation



INCONTROL TOUCH PRO



AVAILABLE AS AN UPGRADE

- 10.2 inch Touch-screen with multi-touch gestures and customisable homescreen
- 12.3 inch instrument panel display with virtual dials and full screen 3D Map View
- InControl Touch Pro Solid State Drive (SSD) Enhanced Navigation
- Meridian Digital Sound System (380W)
- FM Radio, iPod, Bluetooth® and 2 x USB connections
- 10GB of usable memory
- CD/DVD Drive

ADDITIONAL OPTIONS

- Meridian Digital Surround Sound System (825W)
- Digital TV*



8 INCH TOUCH-SCREEN SHOWN AT ACTUAL SIZE

Audio	Standard: Jaguar Sound System (80W) Optional: Meridian Sound System (380W)
Navigation Guidance	InControl Touch SD Navigation*
Display	5 inch instrument panel display with analogue dials
Multimedia	FM Radio, iPod, USB, Bluetooth® and AUX connections

*Optional features.

INCONTROL TOUCH

ADVANCED INFOTAINMENT AS STANDARD

The InControl Touch multimedia system is XF's hub for connectivity, control and entertainment. The key features are:

8 inch Touch-screen at the heart of the centre console. Clear and responsive graphical interface for quick control.

Easy to use Touch-screen responds directly to touch and swipe gestures.

Navigation guidance makes planning journeys and following routes easy, thanks to turn-by-turn voice guidance, junction view and 3D maps. 'Dead-reckoning' functionality can accurately position the vehicle even when GPS signals can no longer be received – perfect for city centres or driving through tunnels.

Bluetooth phone connectivity allows you to link and control your smartphone via InControl Touch either for phone calls or music playback: simple, easy and wire-free.

Access a world of music thanks to FM radio as well as iPod, USB and AUX connections.

Integrated text-to-voice technology reduces distraction by reading out incoming text messages. You can easily respond with short, prepared messages.

Precise climate control is available via the Touch-screen. Adjust temperature levels, direction and intensity of airflow and operate heated or cooled seats (if fitted).



10.2 INCH TOUCH-SCREEN SHOWN AT ACTUAL SIZE

Audio	Standard: Meridian Digital Sound System (380W) Optional: Meridian Digital Surround Sound System (825W)
Navigation Guidance	InControl Touch Pro SSD Enhanced Navigation
Display	12.3 inch instrument panel display with virtual dials and full screen 3D Map View
Multimedia	FM Radio, iPod, Bluetooth® and 2 x USB connections, Digital TV**†, 10GB of usable memory and CD/DVD Drive

*Optional features.

**Market Dependent.

Please consult your local Jaguar retailer for further details. Certain features require the fitment of a SIM with a suitable data contract.



12.3 inch Virtual Instrument Display with four graphical themes

INCONTROL TOUCH PRO



UPGRADE TO NEXT GENERATION INFOTAINMENT

InControl Touch Pro's next-generation hardware and software advances XF's connectivity and entertainment to the very highest level. InControl Touch Pro's features replace or enhance those found in InControl Touch. The key aspects of InControl Touch Pro are:

Larger, highly-responsive, 10.2 inch Touch-screen at the heart of the centre console with customisable home screen and lightning fast response times. Its interactive side panel makes multi-tasking easy.

Pinpoint touch control allows you to manipulate and interact with information swiftly and seamlessly. The Touch-screen responds in the same manner as a smartphone or tablet computer, providing multi-touch gestures such as pinch to zoom and swipe.

12.3 inch Instrument Panel Display with Virtual Dials and full screen 3D Map View makes driving even more of a pleasure. It is housed in the instrument display directly in front of the driver. Select full screen 3D Map View or choose one of four graphical themes to suit your personal preference.

Enhanced Navigation with response times that are a fraction of conventional systems'. One of the many innovative features of InControl Touch Pro's Navigation is that it allows you to set a destination and the system alerts you if you have insufficient fuel for the journey. It then displays filling stations on the part of the route where you may be low on fuel. The system automatically displays parking options.

Personal media storage of 10GB of usable memory for your music and movies. 'Plug and play' using the two USB ports allowing for fast transfer speeds.

As we systematically introduce InControl, specific features, options and its availability remain market dependent. Please consult your local Jaguar retailer for further details. Certain InControl Connect Pro features require the fitment of a Micro SIM with a suitable data contract.

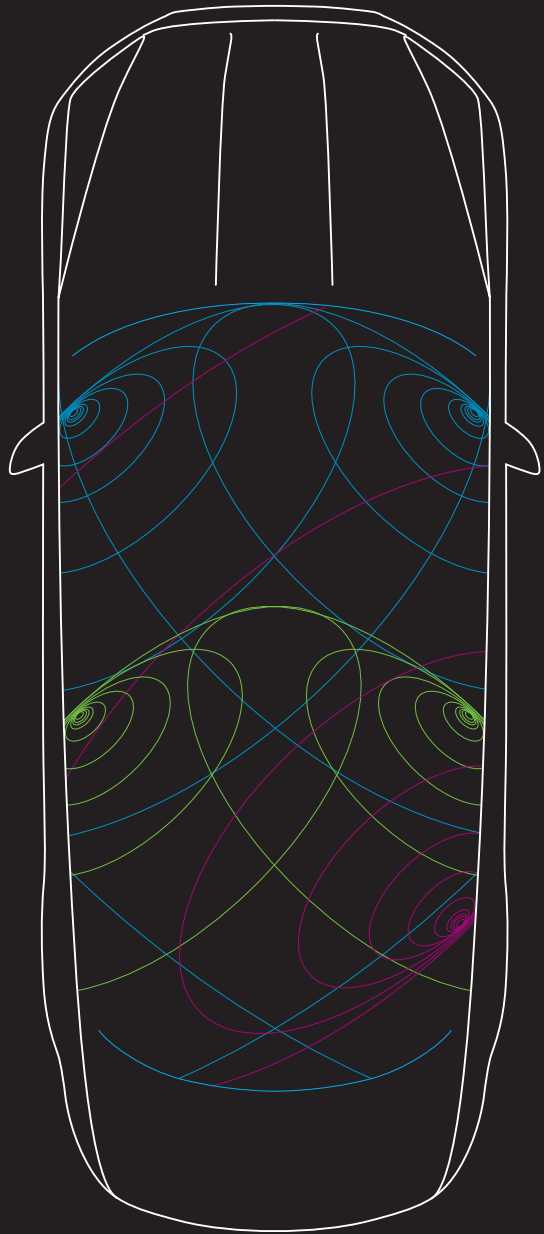

AUDIO

 JAGUAR
SOUND SYSTEM

MERIDIAN
SOUND SYSTEMS

XF's superb sound systems bring your music to life. The Jaguar Sound System provides acoustic range through 8 speakers. Offering an enhanced listening experience are the optional Meridian Sound Systems. Designed in conjunction with the British audio experts Meridian, these systems use innovative audio technology and precise speaker placement to give perfectly optimised sound quality.

Choose from a range of sound systems, including the new digital 380W Sound System with 11 speakers or the digital 825W Surround Sound System with 17 speakers. All ensure that, wherever you or your passengers sit in your XF, everyone will enjoy a rich, enveloping audio experience.



-  Fresh air subwoofer
-  Front door waves tweeter midrange bass
-  Rear door waves tweeter midrange

Diagram representative of Meridian 380W Sound System.



MERIDIAN

SOUND SYSTEMS AVAILABLE IN CONJUNCTION WITH **INCONTROL TOUCH**

Standard

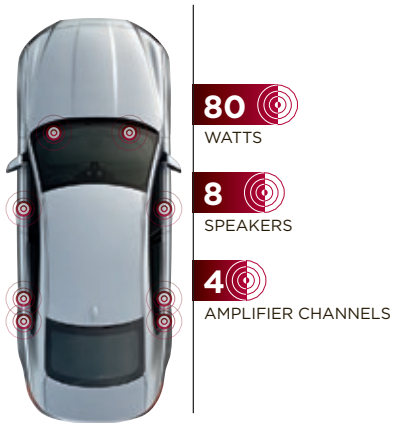

JAGUAR SOUND SYSTEM

Dynamic Volume Control
80 watts; 8 speakers;
4 amplifier channels

Optional

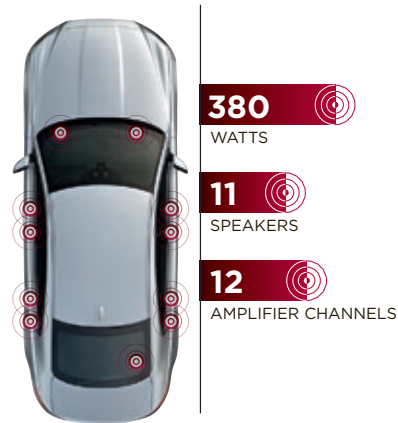

MERIDIAN SOUND SYSTEM

DSP amplifier,
Dynamic Volume Control
380 watts; 11 speakers;
12 amplifier channels

SOUND SYSTEMS AVAILABLE IN CONJUNCTION WITH **INCONTROL TOUCH PRO**

Standard

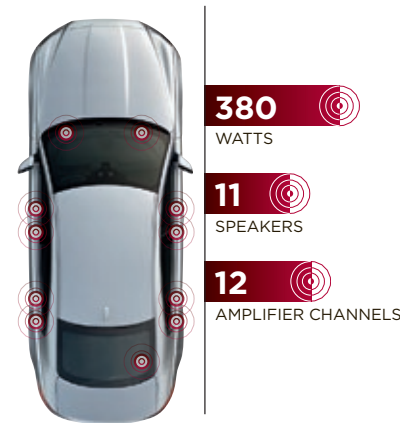

MERIDIAN DIGITAL SOUND SYSTEM

DSP amplifier, Audyssey MultEQ
Audio Equalisation,
Dynamic Volume Control
380 watts; 11 speakers;
12 amplifier channels

Optional

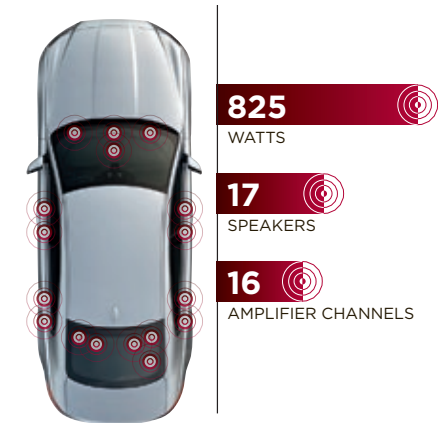

MERIDIAN DIGITAL SURROUND SOUND SYSTEM

DSP amplifier, Audyssey MultEQ
Audio Equalisation,
Dynamic Volume Control
825 watts; 17 speakers;
16 amplifier channels

SAFETY AND EFFICIENCY ADVANCED DRIVER ASSISTANCE



1 BLIND SPOT MONITOR AND REVERSE TRAFFIC DETECTION*

Blind Spot Monitor alerts you to vehicles or obstacles beside XF, as well as ones approaching from a distance behind, via an icon displayed in the appropriate exterior mirror. Reverse Traffic Detection extends the Blind Spot Monitor function and alerts you via the Touch-screen of moving vehicles during reversing - for example, when leaving a parking bay with restricted vision.

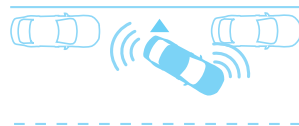

2 PARK ASSIST*

Park Assist makes parking in tight spaces easier than ever. XF can accurately steer itself during both parallel and bay parking manoeuvres - the driver only has to control the brakes and accelerator. An exit-assist function can help guide XF while leaving a parallel space.

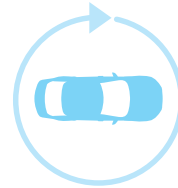

3 SURROUND CAMERA SYSTEM*

Surround Camera System gives you 360° exterior vision on the Touch-screen. This helps with various manoeuvres from parking by a kerb to getting in and out of tight spaces and junctions.

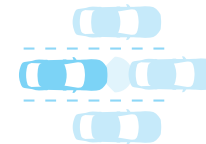

4 ADAPTIVE CRUISE CONTROL WITH QUEUE ASSIST*

Adaptive Cruise Control* uses radar technology to automatically adjust your speed to maintain a safe distance from the vehicle ahead. If that vehicle slows, your XF reduces its speed to maintain a safe distance. XF resumes its pre-set speed as soon as the road in front is clear. Should the car in front stop completely, the Queue Assist function brings XF to a smooth halt. Once the traffic moves off, touch the accelerator and XF will follow the car in front again.

*Optional features, availability is market dependent.

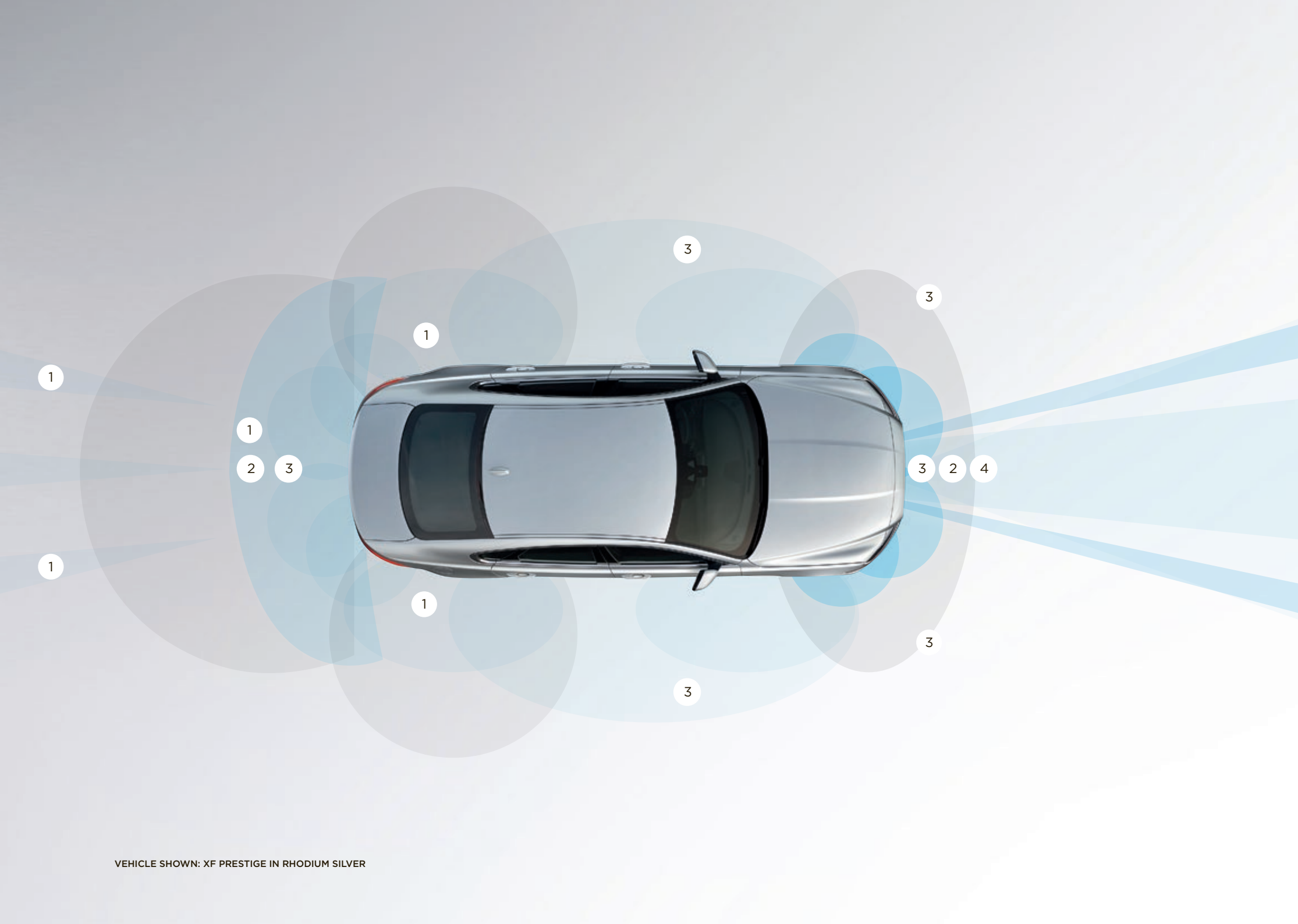

VEHICLE SHOWN: XF PRESTIGE IN RHODIUM SILVER

EFFICIENT TECHNOLOGIES



LOW FRICTION

CLEAN TECHNOLOGIES

Everyone wants to do more with less. That is why XF uses a range of technologies to reduce fuel consumption and CO₂ emissions, all while staying true to Jaguar's dynamic nature.



STOP/START

All XF's engines are available with Stop/Start*. It shuts down the engine when you come to a complete halt and restarts the engine immediately when required. XF's new system reduces battery weight by 10kg to help save fuel, especially during urban driving. XF's air conditioning system will continue to operate as normal during engine shut down. The engine is automatically restarted if the cabin is not being cooled efficiently.

*This is market dependent.

**Available on selected 180PS and 240PS trim levels. This is market dependent.



17" ALLOY WHEELS**

XF is available with a lightweight wheel, with Ultra Low Rolling Resistance tyres to maximise efficiency without loss of Jaguar's legendary comfort.



ADVANCED AERODYNAMICS

XF can offer an incredibly low drag coefficient of Cd. 0.26, matching the best of its rivals. This helps XF cut through the air with ease, meaning less work for the engine and therefore reduced fuel consumption and emissions.



LOW FRICTION TECHNOLOGIES**

Technologies such as smart coatings on XF's pistons and needle roller bearings in the Ingenium range help to reduce friction, particularly at low engine temperatures. This helps the car perform at its efficient best.

PERSONALISATION XF - YOUR CHOICE

 Configure your vehicle at jaguar-me.com



1 CHOOSE YOUR ENGINE

Page 54

Select one of XF's powerful, efficient petrol or diesel* engines to suit your driving style.

2 CHOOSE YOUR MODEL & OPTIONS

Page 56

Compare the wealth of standard features and options on XF models.

3 CHOOSE YOUR COLOUR

Page 64

Express your individuality with one of XF's stunning exterior colours.

*This is market dependent.

CHOOSE YOUR WHEELS

Page 66

Add the personal finishing touch to your new XF, and complement its stunning style, with a set of beautifully designed alloy wheels.

CHOOSE YOUR INTERIOR

Page 68

There's a wide selection of premium materials, leathers, veneers and finishes for every personal taste.

CHOOSE YOUR JAGUAR ACCESSORIES

Page 86

Really make it yours by adding style, practicality and versatility with official XF Accessories from your local Jaguar retailer.

1 CHOOSE YOUR ENGINE

 Configure your vehicle at jaguar-me.com

> DIESEL* ENGINES

2.0 LITRE i4

TURBOCHARGED

MAXIMUM POWER 180PS

MAXIMUM TORQUE 430Nm

ACCELERATION 0-100 km/h 8.1 seconds

TOP SPEED 229 km/h

COMBINED 4.3 l/100km

CARBON DIOXIDE EMISSIONS 114 g/km

PURE, PRESTIGE

3.0 LITRE V6

TWIN TURBOCHARGED

MAXIMUM POWER 300PS

MAXIMUM TORQUE 700Nm

ACCELERATION 0-100 km/h 6.2 seconds

TOP SPEED 250 km/h

COMBINED 5.5 l/100km

CARBON DIOXIDE EMISSIONS 144 g/km

S

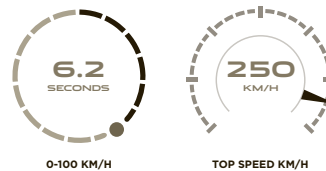
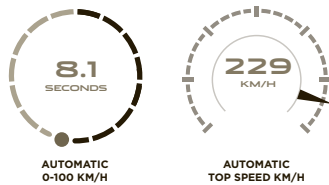

Please refer to Technical Specification pages for full fuel consumption figures.

The figures provided are as a result of official manufacturer's tests in accordance with EU legislation.

A vehicle's actual fuel consumption may differ from that achieved in such tests and these figures are for comparative purposes only.

*This is market dependent.

> PETROL ENGINES

2.0 LITRE i4

TURBOCHARGED

MAXIMUM POWER 240PS

MAXIMUM TORQUE 340Nm

ACCELERATION 0-100 km/h 7.0 seconds

TOP SPEED 248 km/h

COMBINED 7.5 l/100km

CARBON DIOXIDE EMISSIONS 179 g/km

PURE, PRESTIGE, PORTFOLIO, R-SPORT

3.0 LITRE V6

SUPERCHARGED

MAXIMUM POWER 340PS

MAXIMUM TORQUE 450Nm

ACCELERATION 0-100 km/h 5.4 seconds

TOP SPEED 250 km/h

COMBINED 8.3 l/100km

CARBON DIOXIDE EMISSIONS 198 g/km

PRESTIGE, PORTFOLIO, R-SPORT

3.0 LITRE V6

SUPERCHARGED

MAXIMUM POWER 380PS

MAXIMUM TORQUE 450Nm

ACCELERATION 0-100 km/h 5.3 seconds

TOP SPEED 250 km/h

COMBINED 8.3 l/100km

CARBON DIOXIDE EMISSIONS 198 g/km

S



0-100 KM/H



TOP SPEED KM/H



0-100 KM/H



TOP SPEED KM/H



0-100 KM/H



TOP SPEED KM/H

2 CHOOSE YOUR MODEL

 Configure your vehicle at jaguar-me.com

> LUXURY



PURE

KEY FEATURES

- 17" alloy wheels
- Bi-function Xenon headlights with LED J-Blade and powerwash
- Luxtec seats
- 8-way manual front seat with electric recline
- Rear armrest with cupholders
- Gloss Black veneer
- Morse Code Aluminium instrument panel finisher
- All Surface Progress Control



PRESTIGE

KEY FEATURES (IN ADDITION TO PURE)

- 18" alloy wheels
- Electric tilt/slide sunroof
- Taurus leather seats
- 10-way electric front seats
- Soft grain leather steering wheel
- Carpet mats
- Interior Mood Lighting
- Front and Rear Parking Aid
- Rear View Camera



PORTFOLIO

KEY FEATURES (IN ADDITION TO PRESTIGE)

- 19" alloy wheels
- Windsor leather seats
- Windsor leather instrument panel finisher
- Satin Ash Burl veneer
- 14-way electric front luxury seats with 4-way electric lumbar adjust
- Electrically adjustable steering column
- Driver and passenger memory
- 360° Parking aid
- Configurable Interior Mood Lighting

Images feature optional equipment.
Please note that standard features may be replaced when selecting alternative trim levels.
Standard features may also vary depending on country of purchase, engine variant and transmission,
please refer to Specification and Price Guide or website for your local market.

> SPORT



R-SPORT

KEY FEATURES (IN ADDITION TO PRESTIGE)

- 19" alloy wheels
- 'R-Sport' body kit including sports front bumper, side sills and boot mounted spoiler
- Sports suspension (180PS Diesel and 240PS Petrol only)
- Sports Taurus leather seats with technical mesh inserts
- Metal tread plates and multi-function steering wheel with 'R-Sport' branding
- Gloss Black side window surround
- Dark Morse Code Aluminium instrument panel finisher



S

KEY FEATURES (IN ADDITION TO R-SPORT)

- 20" alloy wheels
- 'S' body kit including sports front bumper, Gloss Black side sills, rear valance and boot mounted spoiler
- Red Brake Calipers
- Sports Taurus leather 'S' embossed seats with suedecloth inserts
- Grey Figured Ebony veneer
- Dark Hex Aluminium instrument panel finisher
- Bright sport pedals
- Metal tread plates and multi-function steering wheel with 'S' branding
- Adaptive Dynamics
- Meridian Sound System (380W)

2 CHOOSE YOUR OPTIONS

 Configure your vehicle at jaguar-me.com

KEY STANDARD FEATURES

		PURE	PRESTIGE	PORTFOLIO	R-SPORT	S	DESCRIPTION
Eight-speed automatic transmission with Jaguar Sequential Shift, gearshift change paddles and All Surface Progress Control		●	●	●	●	●	Refer to page 22
Intelligent Stop/Start system		●	●	●	●	●	Refer to page 50
Infrared Reflective windscreen (front screen only)	D97B	○	○	○	○	○	Filters sunlight to reduce glare and prevent harmful UV rays from entering the cabin
Bi-function Xenon headlights with LED J-Blade Daytime Running Lights, automatic levelling and headlight powerwash	D90L	●	●	●	●	●	
Hill Launch Assist		●	●	●	●	●	Prevents your XF from rolling backwards when pulling away on an incline, helping you to make the perfect hill start every time
JaguarDrive Control with Eco, Dynamic, Normal and Winter mode		●	●	●	●	●	Refer to page 22
Electric Power Assisted Steering (EPAS)		●	●	●	●	●	Refer to page 31
Electric Parking Brake with drive away release		●	●	●	●	●	Automatically releases the parking brake without the need for driver input as you press the accelerator to drive away
Emergency Brake Assist		●	●	●	●	●	Increases braking pressure in an emergency situation
Hazard lights under heavy braking		●	●	●	●	●	
Airbags		●	●	●	●	●	Driver and front passenger with seat occupant detector for passenger, front side and full length side window curtain
Torque Vectoring		●	●	●	●	●	Refer to page 36
Dynamic Stability Control and Traction Control		●	●	●	●	●	Refer to page 39
Cruise Control with Speed Limiter		●	●	●	●	●	
Trailer Stability Control		●	●	●	●	●	Intervenes when the system detects sway or potentially dangerous movement to bring the trailer back under control
Electric front and rear windows with one-touch open/close and anti-trap		●	●	●	●	●	
Rain sensing windscreen wipers		●	●	●	●	●	
Body coloured, heated, electric exterior door mirror		●	●	●	●	●	
Two-zone climate control		●	●	●	●	●	
USB, Auxiliary socket and iPod® connectivity		●	●	●	●	●	Refer to page 41
Bluetooth® telephone connectivity		●	●	●	●	●	Refer to page 41
Bluetooth® streaming		●	●	●	●	●	Refer to page 41
Interior lighting		●	●	●	●	●	
Jaguar Smart Key System – Keyless Start		●	●	●	●	●	
Space saver spare wheel (18")	C40D	○	○	○	○	○	
Tyre Pressure Monitoring System		●	●	●	●	●	
40:20:40 split fold rear seat with arm rest	H48W	●	●	●	●	●	

*Not available on V6 engines.

● Standard ○ Option — Not available

Please consult your local Jaguar retailer for details.

For a complete list of optional features and packs refer to the XF Specification and Price Guide or configure your vehicle at jaguar-me.com

KEY OPTIONAL FEATURES

		PURE	PRESTIGE	PORTFOLIO	R-SPORT	S	
DYNAMIC FEATURES		CODE					DESCRIPTION
Sports suspension upgrade*	C31S	○	○	○	●	—	Adds Sports springs and dampers
Adaptive Dynamics (includes Configurable Dynamics when V6 engine with InControl Touch is selected)	C35A	—	○	○	○	●	Refer to page 29 and 31
Adaptive Cruise Control with Queue Assist (requires automatic transmission)	H41F	○	○	○	○	○	Refer to page 48

EXTERIOR FEATURES AND FINISHERS

EXTERIOR FEATURES AND TRIM							
Electric tilt/slide sunroof	F45C	○	●	●	●	●	
Powered Electrical boot lid (open and close)	B69B	○	○	●	○	●	
Soft Door Close (requires Keyless Entry)	F42D/F42C	○	○	○	○	○	Automatically ensures that doors close softly, securely and with minimum exertion
Chrome radiator grille with Chrome surround	G12V	—	○	○	—	—	
Chrome side window surround	D53C	●	●	●	○	○	
R-Sport body kit		—	—	—	●	—	Includes R-Sport front bumper, body coloured side sills and boot lid mounted spoiler, Satin Chrome side power vents with R-Sport badge
S body kit		—	—	—	—	●	Includes S front bumper, Gloss Black side sills and rear valance, body coloured boot lid mounted spoiler, Satin Chrome side power vents
Engine De-badge	B05H	○	○	○	○	—	Removes engine badging

2 CHOOSE YOUR OPTIONS

 Configure your vehicle at jaguar-me.com

EXTERIOR FEATURES AND FINISHERS CONTINUED

		PURE	PRESTIGE	PORTFOLIO	R-SPORT	S	
GLASS AND EXTERIOR MIRRORS							DESCRIPTION
Heated front windscreen with heated washer jets	D96A	<input type="radio"/>	<input type="radio"/>	<input type="radio"/>	<input type="radio"/>	<input type="radio"/>	
Power fold exterior mirrors in body colour, heated and auto-dimming with approach lamps and clear side turn indicators	B28P	<input type="radio"/>	<input checked="" type="radio"/>	<input type="radio"/>	<input checked="" type="radio"/>	<input type="radio"/>	
HEADLIGHTS AND LIGHTING							
LED headlights with LED J-Blade Daytime Running Lights, adaptive lighting, turning light, Automatic High Beam Assist and headlight powerwash	D90T	<input type="radio"/>	<input type="radio"/>	<input type="radio"/>	<input type="radio"/>	<input type="radio"/>	Refer to page 10
TOWING							
Detachable tow bar	C05C	<input type="radio"/>	<input type="radio"/>	<input type="radio"/>	<input type="radio"/>	<input type="radio"/>	
Electrically deployable tow bar	C05B	<input type="radio"/>	<input type="radio"/>	<input type="radio"/>	<input type="radio"/>	<input type="radio"/>	
EXTERIOR COLOURS							(Please see pages 64-65 for full colour palette)
Solid paint		<input type="radio"/>	<input type="radio"/>	<input type="radio"/>	<input type="radio"/>	<input type="radio"/>	Refer to page 64
Metallic paint		<input type="radio"/>	<input type="radio"/>	<input type="radio"/>	<input type="radio"/>	<input type="radio"/>	Refer to page 64-65
Premium paint		<input type="radio"/>	<input type="radio"/>	<input type="radio"/>	<input type="radio"/>	<input type="radio"/>	Refer to page 65

● Standard ○ Option — Not available

Please consult your local Jaguar retailer for details.

For a complete list of optional features and packs refer to the XF Specification and Price Guide or configure your vehicle at jaguar-me.com

SEATING AND VENEERS

		PURE	PRESTIGE	PORTFOLIO	R-SPORT	S	
SEATING	CODE						DESCRIPTION
Heated front seats	F53A	○	○	—	○	○	
Heated front and rear seats	F53B	—	○	—	○	○	
Climate front seats (requires leather seats and 4-way electric lumbar adjust)	F53F	—	○	●	○	○	Heated and cooled front seats
Climate front seats and heated rear seats (requires leather seats and 4-way electric lumbar adjust)	F53C	—	○	○	○	○	Heated and cooled front and rear seats
8-way manual front seat with electric recline (standard on 163PS engine only)		●	—	—	—	—	
10-way electric front seats with manual headrest height (optional on 163PS engine only)	Z03V	○	●	—	●	●	
4-way electric lumbar adjust (only available with 10-way seats)	F52A	○	○	—	○	●	
Driver Memory (only available with 10-way seats)	H44N	○	○	—	○	●	Adjusts driver seat, mirrors and steering column
14-way electric front Sports seats	Z03Q	—	—	—	—	○	With manual headrest height, 4-way electric lumbar adjust and Passenger and Driver Memory
14-way electric front Luxury seats	Z03Z	—	—	●	—	—	With manual headrest height, 4-way electric lumbar adjust and Passenger and Driver Memory
Sports Taurus leather seats	B41T	—	—	—	●	○	

VENEERS

Please see pages 84-85 for full range of veneers

HEADLINING AND INTERIOR FEATURES

HEADLINING						
Light Oyster headlining	HAMT	●	●	●	○	○
Jet headlining	HPDB	○	○	○	●	●
Suedecloth headlining	H01D	○	○	○	○	○

2 CHOOSE YOUR OPTIONS

 Configure your vehicle at jaguar-me.com

HEADLINING AND INTERIOR FEATURES CONTINUED

		PURE	PRESTIGE	PORTFOLIO	R-SPORT	S	
INTERIOR FEATURES		CODE					DESCRIPTION
Illuminated metal tread plates with Jaguar script	F28F	—	○	○	○	○	
Carpet mats	H69H	○	●	—	●	●	
Premium carpet mats	H69K	○	○	●	○	○	
Bright Sport pedals	G48S	○	○	○	○	●	
Heated steering wheel (requires heated front seats)	F97A	○	○	○	○	○	
Electrically adjustable steering column	D07J	○	○	●	○	●	
Auto-dimming Interior Rear View Mirror	B68B	○	●	●	●	●	
Timed climate with remote heat function	H10F	○	○	○	○	○	
Four-zone climate control with two additional power sockets (requires Air Quality Sensor and Cooled Glove Box)	C88G	○	●	●	●	●	Refer to page 96
Air Quality Sensor and Cooled Glove Box	C89A, B23H	○	●	●	●	●	
Manual rear side window sunblinds	H73B	○	○	○	○	○	
Electric rear window sunblind	H76G	○	○	●	○	●	
Interior Mood Lighting	B65A	○	●	—	●	●	
Configurable Interior Mood Lighting with ten colours	B65B	○	○	●	○	○	Refer to page 19
Smoker's Pack	A03B	○	●	●	●	●	Includes single ashtray and single cigar lighter
Two additional power sockets	D72B	○	—	—	—	—	Additional 12V power socket in rear centre console and boot
SAFETY AND SECURITY							
Front Parking Aid (requires Rear Parking Aid)	C13A	○	●	●	●	●	
Rear Parking Aid	C11A	○	●	●	●	●	
Rear View Camera	C14A	○	●	●	●	●	
Surround Camera System (requires power fold mirrors)	C14D	○	○	○	○	○	Refer to page 48
Park Assist (requires Front and Rear Parking Aids)	C18B	○	○	○	○	○	Parallel and Perpendicular Parking
360° Parking Aid (requires Front and Rear Parking Aids)	C17A	○	○	●	○	○	
Garage door opener (HomeLink®, requires Auto-dimming Interior Rear View Mirror)	B39N	○	○	○	○	○	
Blind Spot Monitor and Reverse Traffic Detection (requires power fold mirrors and Rear Parking Aid)	H71C	○	○	○	○	○	Refer to page 48
Jaguar Smart Key System – Keyless Entry	F04B	○	○	●	○	○	

● Standard ○ Option — Not available

Please consult your local Jaguar retailer for details.

For a complete list of optional features and packs refer to the XF Specification Guide or configure your vehicle at jaguar-me.com

INFORMATION, COMMUNICATION AND ENTERTAINMENT

		PURE	PRESTIGE	PORTFOLIO	R-SPORT	S	
FEATURES ONLY AVAILABLE WITH INCONTROL TOUCH							
InControl Touch with 8 inch Touch-screen		●	●	●	●	●	Refer to page 43
5 inch instrument panel display with analogue dials		●	●	●	●	●	Refer to page 43
InControl Touch SD Navigation	G61C	○	○	●	○	●	Refer to page 43
Jaguar Sound System (80W)		●	●	—	●	—	Refer to page 46-47
Meridian™ Sound System (380W)	B44V	○	○	●	○	●	Refer to page 46-47
FEATURES ONLY AVAILABLE WITH OPTIONAL INCONTROL TOUCH PRO							
InControl Touch Pro with 10.2 inch Touch-screen, 12.3 inch HD Virtual Instrument Display, SSD Navigation and Meridian™ Digital Sound System (380W)	Z59X	○	○	○	○	○	Refer to page 44-45
InControl Touch Pro with 10.2 inch Touch-screen, 12.3 inch HD Virtual Instrument Display, SSD Navigation and Meridian™ Digital Surround Sound (825W)	Z59Y	○	○	○	○	○	Refer to page 44-45
Digital TV Tuner	G52G	○	○	○	○	○	Refer to page 41
FEATURES ONLY AVAILABLE WITH INCONTROL TOUCH AND INCONTROL TOUCH PRO							
Head-Up Display with Infrared Reflective Windscreen	Z13A	○	○	○	○	○	Refer to page 39
OPTION PACKS							
Cold Climate Pack	Z88D	○	○	○	○	○	Consists of heated front windscreen, heated washer jets, heated steering wheel and heated front and rear seats (heated front only on Pure)
Power Convenience Pack	Z28B	○	○	—	○	—	Consists of Keyless Entry, powered electrical boot lid and 2 additional power sockets
Parking Pack	Z68S	○	—	—	—	—	Consists of Front and Rear Parking Aids and rear view camera
Advanced Park Assist Pack	Z68T	○	○	—	○	○	Consists of Parking Pack features plus 360° Parking Aid and Park Assist. Refer to page 48
Advanced Park Assist Pack with Surround Camera System	Z68U	○	○	○	○	○	Consists of Advanced Parking Assist Pack features plus Surround Camera System (replaces rear view camera). Refer to page 48
Active Safety Pack	Z76C	○	○	○	○	○	Consists of Adaptive Cruise Control with Queue Assist (only available with automatic transmission), Lane Keep Assist and Driver Condition Monitor, Blind Spot Monitor and Reverse Traffic Detection (requires power fold mirrors and Rear Parking Aid)
Black Pack	Z93L	—	○	○	○	○	Consists of Gloss Black radiator grille and surround, side power vents, boot lid finisher, side window surround and body kit blades (except S)
Rear Comfort Pack	Z12A	○	○	—	○	○	Consists of heated front and rear seats (heated front seats only on Pure), four-zone climate control, manual rear side window sunblinds and electric rear window sunblind (requires Air Quality Sensor and Cooled Glove Box)

3 CHOOSE YOUR COLOUR

 Configure your vehicle at [jaguar-me.com](https://www.jaguar-me.com)

SOLID

Polaris White

Ebony Black

METALLIC

Glacier White

Ultimate Black

Rhodium Silver

Ammonite Grey

Dark Sapphire Blue

British Racing Green

Italian Racing Red

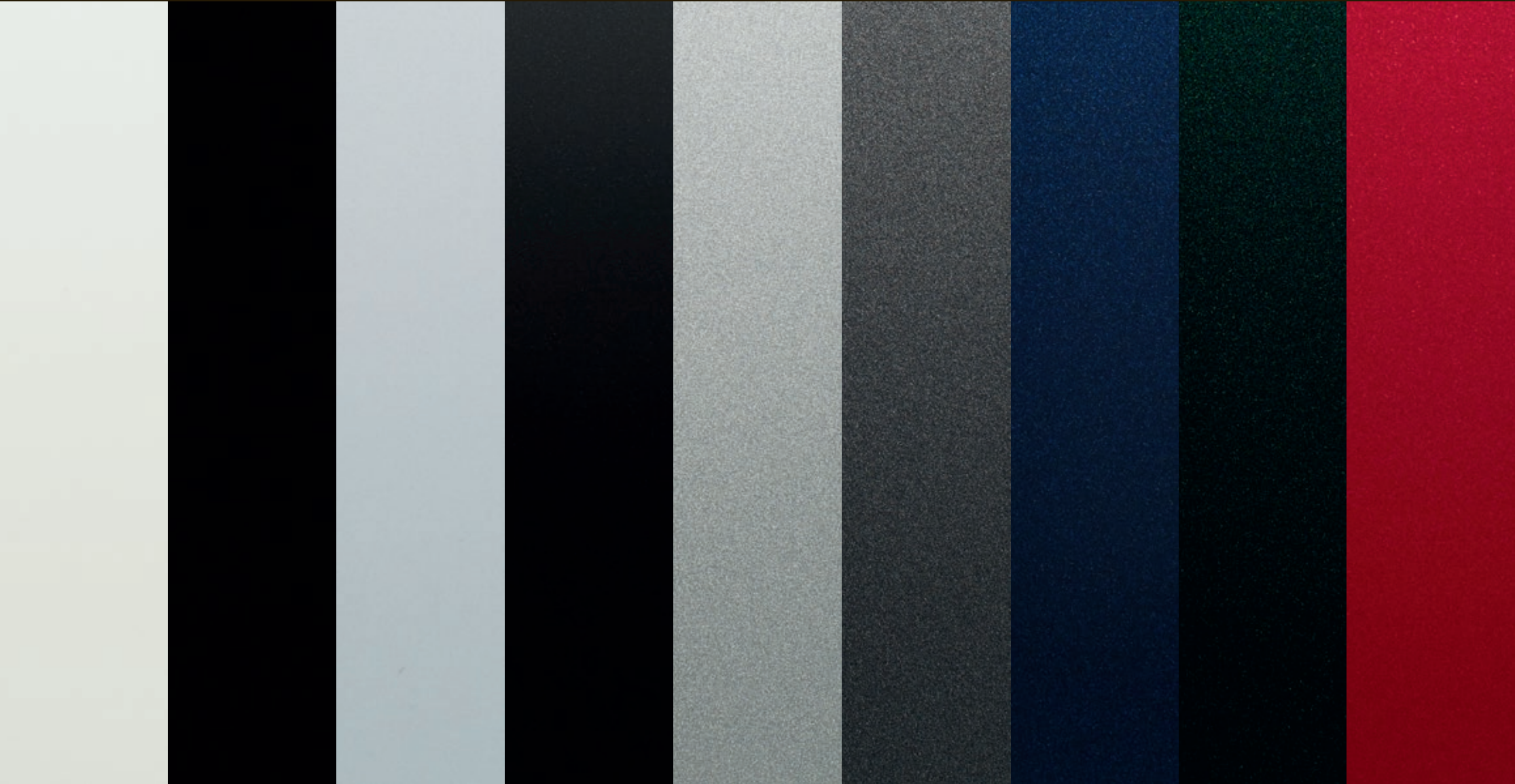

PREMIUM PALETTE

Quartzite

Odyssey Red

Aurora Red

Storm Grey

Black Berry

Tempest Grey

Celestial Black

Ingot



4 CHOOSE YOUR WHEELS

 Configure your vehicle at jaguar-me.com



17" LIGHTWEIGHT
15 SPOKE¹



17" TURBINE
9 SPOKE



18" FAN
5 SPOKE



18" CHALICE
7 TWIN SPOKE



18" HELIX
10 SPOKE

ALLOY WHEEL FINISH	Sparkle Silver	Sparkle Silver	Sparkle Silver	Sparkle Silver	Sparkle Silver
ALLOY WHEEL/SIZE	7.5J x 17"	7.5J x 17"	8.0J x 18"	8.0J x 18"	8.0J x 18"
TYRE SIZE	225/55 R17	225/55 R17	245/45 R18	245/45 R18	245/45 R18
CODE	C54B	C54C	C53R	C53S	C53T
Pure	<input type="radio"/>	<input checked="" type="radio"/>	<input type="radio"/>	<input type="radio"/>	<input type="radio"/>
Prestige	<input type="radio"/>	<input type="radio"/>	<input type="radio"/>	<input checked="" type="radio"/>	<input type="radio"/>
Portfolio	<input type="radio"/>	<input type="radio"/>	<input type="radio"/>	<input type="radio"/>	<input type="radio"/>
R-Sport	<input type="radio"/>	<input type="radio"/>	<input type="radio"/>	<input type="radio"/>	<input type="radio"/>
S	<input type="radio"/>	<input type="radio"/>	<input type="radio"/>	<input type="radio"/>	<input type="radio"/>



18" HELIX
10 SPOKE



18" HELIX
10 SPOKE



19" RAZOR
7 TWIN SPOKE



19" AXIS
14 SPOKE



19" AXIS
14 SPOKE

ALLOY WHEEL FINISH	Contrast/Diamond Turned	Gloss Black	Sparkle Silver	Sparkle Silver	Contrast/Diamond Turned
ALLOY WHEEL/SIZE	8.0J x 18"	8.0J x 18"	8.0J x 19"	8.0J x 19"	8.0J x 19"
TYRE SIZE	245/45 R18	245/45 R18	245/40 R19	245/40 R19	245/40 R19
CODE	C53P	C53P	C53U	C53V	C53Z
Pure	<input type="radio"/>	<input type="radio"/>	<input type="radio"/>	<input type="radio"/>	<input type="radio"/>
Prestige	<input type="radio"/>	<input type="radio"/>	<input type="radio"/>	<input type="radio"/>	<input type="radio"/>
Portfolio	<input type="radio"/>	<input type="radio"/>	<input checked="" type="radio"/>	<input type="radio"/>	<input type="radio"/>
R-Sport	<input type="radio"/>	<input type="radio"/>	<input type="radio"/>	<input type="radio"/>	<input type="radio"/>
S	<input type="radio"/>	<input type="radio"/>	<input type="radio"/>	<input type="radio"/>	<input type="radio"/>

● Standard ○ Option — Not Applicable

¹Only available on i4 engines. ²Optional on i4 engines, standard on V6 engines.

Standard and optional features may differ depending on market availability.



19" VORTEX
10 SPOKE



19" BLADE
5 SPOKE



19" BLADE
5 SPOKE



20" MATRIX
9 TWIN SPOKE



20" MATRIX
9 TWIN SPOKE

ALLOY WHEEL FINISH	Sparkle Silver	Gloss Grey/Diamond Turned	Gloss Black	Sparkle Silver	Contrast/Diamond Turned
ALLOY WHEEL/SIZE	8.0J x 19"	8.0J x 19"	8.0J x 19"	8.5J x 20"	8.5J x 20"
TYRE SIZE	245/40 R19	245/40 R19	245/40 R19	255/35 R20	255/35 R20
CODE	C53W	C53Y	C53X	C53H	C53J

Pure	<input type="radio"/>	<input type="radio"/>	<input type="radio"/>	<input type="radio"/>	<input type="radio"/>
Prestige	<input type="radio"/>	<input type="radio"/>	<input type="radio"/>	<input type="radio"/>	<input type="radio"/>
Portfolio	<input type="radio"/>	<input type="radio"/>	<input type="radio"/>	<input type="radio"/>	<input type="radio"/>
R-Sport	<input type="radio"/>	<input checked="" type="radio"/>	<input type="radio"/>	<input type="radio"/>	<input type="radio"/>
S	<input type="radio"/>	<input type="radio"/>	<input type="radio"/>	<input type="radio"/>	<input type="radio"/>



20" STAR
5 TWIN SPOKE



20" VENOM
5 TWIN SPOKE



20" VENOM
5 TWIN SPOKE



20" LABYRINTH
5 TWIN SPOKE

ALLOY WHEEL FINISH	Sparkle Silver	Gloss Dark Grey/Diamond Turned	Gloss Black	Gloss Dark Grey/Diamond Turned
ALLOY WHEEL/SIZE	8.5J x 20"	8.5J x 20"	8.5J x 20"	8.5J x 20"
TYRE SIZE	255/35 R20	255/35 R20	255/35 R20	255/35 R20
CODE	C53K	C53F	C53L	C53G

Pure	<input type="radio"/>	<input type="radio"/>	<input type="radio"/>	<input type="radio"/>
Prestige	<input type="radio"/>	<input type="radio"/>	<input type="radio"/>	<input type="radio"/>
Portfolio	<input type="radio"/>	<input type="radio"/>	<input type="radio"/>	<input type="radio"/>
R-Sport	<input type="radio"/>	<input type="radio"/>	<input type="radio"/>	<input type="radio"/>
S	<input type="radio"/>	<input type="radio"/>	<input type="radio"/>	<input checked="" type="radio"/>

5 CHOOSE YOUR INTERIOR

 Configure your vehicle at jaguar-me.com

PURE						
	SEAT WITH TONAL STITCH	UPPER FACIA WITH TONAL STITCH	INTERIOR TRIM AND OPTION CODES	HEADLINING MORZINE*	CARPET	VENEER
Standard						
Luxtec Seats	Jet with Jet	Jet with Jet	TR23	Jet** or Light Oyster	Jet	Gloss Black
	Latte with Latte	Espresso with Espresso	TR24	Light Oyster	Espresso	Gloss Black
	Light Oyster with Light Oyster	Oyster with Oyster	TR25	Light Oyster	Oyster	Gloss Black
PRESTIGE						
	SEAT WITH TONAL STITCH	UPPER FACIA WITH TONAL STITCH	INTERIOR TRIM AND OPTION CODES	HEADLINING MORZINE*	CARPET	VENEER
Standard						
Taurus Leather seats	Jet with Jet	Jet with Jet	TR26	Jet** or Light Oyster	Jet	Gloss Black
	Latte with Latte	Espresso with Espresso	TR27	Light Oyster	Espresso	Gloss Black
	Light Oyster with Light Oyster	Oyster with Oyster	TR28	Light Oyster	Oyster	Gloss Black
PORTFOLIO						
	SEAT WITH TONAL STITCH	UPPER FACIA WITH TONAL STITCH	INTERIOR TRIM AND OPTION CODES	HEADLINING MORZINE*	CARPET	VENEER
Standard						
Windsor Leather seats	Jet with Jet	Jet with Jet	TR37	Jet** or Light Oyster	Jet	Gloss Figured Ebony
	Latte with Latte	Espresso with Espresso	TR38	Light Oyster	Espresso	Gloss Figured Ebony
	Light Oyster with Light Oyster	Oyster with Oyster	TR39	Light Oyster	Oyster	Gloss Figured Ebony
	Espresso with Espresso	Espresso with Espresso	TR40	Light Oyster	Espresso	Gloss Figured Ebony
	Siena Tan with Siena Tan	Jet with Jet	TR41	Jet** or Light Oyster	Jet	Gloss Figured Ebony

*Suedecloth headlining available as an option.
 **Jet headlining available as an option.
 †Light Oyster headlining available as an option.

R-SPORT						
	DUOTONE SEAT WITH CONTRAST STITCH	UPPER FACIA WITH CONTRAST STITCH	INTERIOR TRIM AND OPTION CODES	HEADLINING MORZINE*	CARPET	VENEER
Standard						
Taurus Leather Sports seats	Jet/Jet with Light Oyster	Jet with Light Oyster	TR29 + B41T	Jet or Light Oyster†	Jet	Gloss Black
	Jet/Red with Red	Jet with Red	TR30	Jet or Light Oyster†	Jet	Gloss Black
	Jet/Light Oyster with Light Oyster	Jet with Light Oyster	TR31	Jet or Light Oyster†	Jet	Gloss Black
	Brogue/Brogue with Light Oyster	Jet with Light Oyster	TR32	Jet or Light Oyster†	Jet	Gloss Black
Optional						
Sports Taurus Leather seats with technical mesh inserts	Jet/Jet with Light Oyster	Jet with Light Oyster	TR29	Jet or Light Oyster†	Jet	Gloss Black
S						
	DUOTONE SEAT WITH CONTRAST STITCH	UPPER FACIA WITH CONTRAST STITCH	INTERIOR TRIM AND OPTION CODES	HEADLINING MORZINE*	CARPET	VENEER
Standard						
Sports Taurus Leather seats with Suedecloth inserts	Jet/Jet with Light Oyster	Jet with Light Oyster	TR33	Jet or Light Oyster†	Jet	Grey Figured Ebony
	Red/Jet with Jet	Jet with Red	TR34	Jet or Light Oyster†	Jet	Grey Figured Ebony
Optional						
Taurus Leather Sports seats	Jet/Jet with Light Oyster	Jet with Light Oyster	TR33 + B41T	Jet or Light Oyster†	Jet	Grey Figured Ebony
	Red/Jet with Jet	Jet with Red	TR34 + B41T	Jet or Light Oyster†	Jet	Grey Figured Ebony
	Light Oyster/Jet with Jet	Jet with Light Oyster	TR35	Jet or Light Oyster†	Jet	Grey Figured Ebony
	Brogue/Brogue with Light Oyster	Jet with Light Oyster	TR36	Jet or Light Oyster†	Jet	Grey Figured Ebony

5 CHOOSE YOUR INTERIOR

⚙️ Configure your vehicle at [jaguar-me.com](https://www.jaguar-me.com)















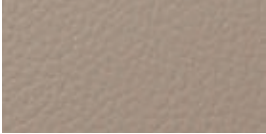

Interior shown: Jet Luxtec seats with Jet facia, Morse Code Aluminium finisher, Gloss Black veneer and optional Jet headlining.



PURE

INTERIOR COLOUR COMBINATIONS

STANDARD

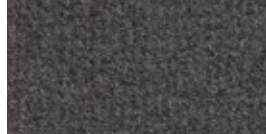
1	2	3	4	5	6
SEAT WITH TONAL STITCH	veneer	HEADLINING MORZINE*	UPPER FACIA WITH TONAL STITCH	FINISHER	CARPETS
					
Jet	Gloss Black	Jet** or Light Oyster	Jet with Jet	Morse Code Aluminium	Jet
					
Latte	Gloss Black	Light Oyster	Espresso with Espresso	Morse Code Aluminium	Espresso
					
Light Oyster	Gloss Black	Light Oyster	Oyster with Oyster	Morse Code Aluminium	Oyster

VENEER OPTIONS

Carbon Fibre Veneer, Satin Ash Burl Veneer, Gloss Figured Ebony Veneer, Grey Figured Ebony Veneer, Satin Fine Line Veneer, Satin Rosewood Veneer or Gloss Burr Walnut Veneer

*Suedecloth headlining available as an option.
 **Jet headlining available as an option.

5 CHOOSE YOUR INTERIOR

⚙️ Configure your vehicle at [jaguar-me.com](https://www.jaguar-me.com)

















Interior shown: Jet Taurus leather seats with Jet tonal stitch, Jet fascia, Morse Code Aluminium finisher, Gloss Black veneer and optional Jet headlining.



PRESTIGE

INTERIOR COLOUR COMBINATIONS

STANDARD

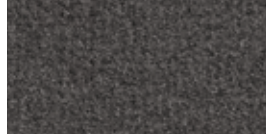
1	2	3	4	5	6
SEAT WITH TONAL STITCH	VENEER	HEADLINING MORZINE*	UPPER FACIA WITH TONAL STITCH	FINISHER	CARPETS
					
Jet with Jet	Gloss Burr Walnut	Jet** or Light Oyster	Jet with Jet	Morse Code Aluminium	Jet
					
Latte with Latte	Gloss Burr Walnut	Light Oyster	Espresso with Espresso	Morse Code Aluminium	Espresso
					
Light Oyster with Light Oyster	Gloss Burr Walnut	Light Oyster	Oyster with Oyster	Morse Code Aluminium	Oyster

VENEER OPTIONS

Carbon Fibre Veneer, Gloss Figured Ebony Veneer, Gloss Figured Ebony Veneer, Grey Figured Ebony Veneer, Satin Fine Line Veneer, Satin Rosewood Veneer or Gloss Black Veneer

*Suedecloth headlining available as an option.
 **Jet headlining available as an option.

5 CHOOSE YOUR INTERIOR

⚙️ Configure your vehicle at [jaguar-me.com](https://www.jaguar-me.com)

















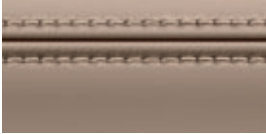









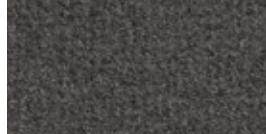

Interior shown: Latte Windsor leather seats with Latte tonal stitch, Espresso facia, Morse Code Aluminium finisher, Gloss Figured Ebony veneer and Light Oyster headlining.



PORTFOLIO

INTERIOR COLOUR COMBINATIONS

STANDARD

1	2	3	4	5	6
SEAT WITH TONAL STITCH	VENEER	HEADLINING MORZINE*	UPPER FACIA WITH TONAL STITCH	FINISHER	CARPETS
 Jet with Jet	 Satin Ash Burl	 Jet** or Light Oyster	 Jet with Jet	 Morse Code Aluminium	 Jet
 Latte with Latte	 Satin Ash Burl	 Light Oyster	 Espresso with Espresso	 Morse Code Aluminium	 Espresso
 Light Oyster with Light Oyster	 Satin Ash Burl	 Light Oyster	 Oyster with Oyster	 Morse Code Aluminium	 Oyster
 Espresso with Espresso	 Satin Ash Burl	 Light Oyster	 Espresso with Espresso	 Morse Code Aluminium	 Espresso
 Siena Tan with Siena Tan	 Satin Ash Burl	 Jet** or Light Oyster	 Jet with Jet	 Morse Code Aluminium	 Jet

VENEER OPTIONS

Gloss Black Veneer, Carbon Fibre Veneer, Gloss Figured Ebony Veneer, Grey Figured Ebony Veneer, Satin Fine Line Veneer, Satin Rosewood Veneer or Gloss Burr Walnut Veneer

*Suedecloth headlining available as an option.
**Jet headlining available as an option.

5 CHOOSE YOUR INTERIOR

⚙️ Configure your vehicle at [jaguar-me.com](https://www.jaguar-me.com)







Interior shown: Jet Taurus leather Sports seats with Jet technical mesh inserts and Light Oyster contrast stitch, Jet fascia with Light Oyster contrast stitch, Dark Morse Code Aluminium finisher, Gloss Black veneer and optional Light Oyster headlining.



R-SPORT

INTERIOR COLOUR COMBINATIONS

STANDARD

①	②	③	④	⑤	⑥
DUOTONE SEAT WITH CONTRAST STITCH	VENEER	HEADLINING MORZINE*	UPPER FACIA WITH CONTRAST STITCH	FINISHER	CARPETS
					
Jet/Jet with Light Oyster	Gloss Black	Jet or Light Oyster**	Jet with Light Oyster	Dark Morse Code Aluminium	Jet

VENEER OPTIONS

Carbon Fibre Veneer, Satin Ash Burl Veneer, Gloss Figured Ebony Veneer, Grey Figured Ebony Veneer, Satin Fine Line Veneer, Satin Rosewood Veneer or Gloss Burr Walnut Veneer

*Suedecloth headlining available as an option.

**Light Oyster headlining available as an option.

5 CHOOSE YOUR INTERIOR

⚙️ Configure your vehicle at jaguar-me.com













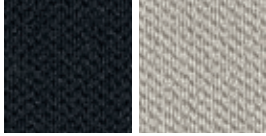
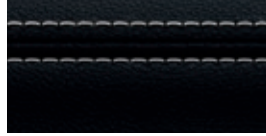



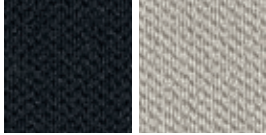
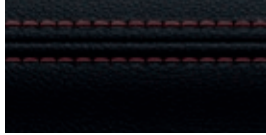



Interior shown: Jet and Light Oyster perforated Taurus leather Sports seats with Light Oyster contrast stitch, Jet fascia with Light Oyster contrast stitch, Dark Morse Code Aluminium finisher, optional Satin Fine Line veneer and optional Light Oyster headlining.

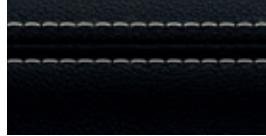

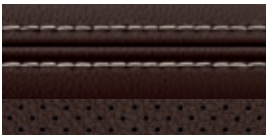
R-SPORT

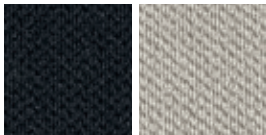
INTERIOR COLOUR COMBINATIONS

OPTIONS

1	2	3	4	5	6
<p>DUOTONE SEAT WITH CONTRAST STITCH</p>  <p>Jet/Jet with Light Oyster</p>	<p>VENEER</p>  <p>Gloss Black</p>	<p>HEADLINING MORZINE*</p>  <p>Jet or Light Oyster**</p>	<p>UPPER FACIA WITH CONTRAST STITCH</p>  <p>Jet with Light Oyster</p>	<p>FINISHER</p>  <p>Dark Morse Code Aluminium</p>	<p>CARPETS</p>  <p>Jet</p>
 <p>Jet/Red with Red</p>	 <p>Gloss Black</p>	 <p>Jet or Light Oyster**</p>	 <p>Jet with Red</p>	 <p>Dark Morse Code Aluminium</p>	 <p>Jet</p>
 <p>Jet/Light Oyster with Light Oyster</p>	 <p>Gloss Black</p>	 <p>Jet or Light Oyster**</p>	 <p>Jet with Light Oyster</p>	 <p>Dark Morse Code Aluminium</p>	 <p>Jet</p>
 <p>Brogue/Brogue with Light Oyster</p>	 <p>Gloss Black</p>	 <p>Jet or Light Oyster**</p>	 <p>Jet with Light Oyster</p>	 <p>Dark Morse Code Aluminium</p>	 <p>Jet</p>

VENEER OPTIONS

Carbon Fibre Veneer, Satin Ash Burl Veneer, Gloss Figured Ebony Veneer, Grey Figured Ebony Veneer, Satin Fine Line Veneer, Satin Rosewood Veneer or Gloss Burr Walnut Veneer

*Suedecloth headlining available as an option.
 **Light Oyster headlining available as an option.

5 CHOOSE YOUR INTERIOR

⚙️ Configure your vehicle at [jaguar-me.com](https://www.jaguar-me.com)

Interior shown: Jet Taurus leather Sports seats with Jet Suedecloth inserts and Light Oyster contrast stitch, Jet fascia with Light Oyster contrast stitch, Dark Hex Aluminium finisher, Grey Figured Ebony veneer and Jet headlining.



S

INTERIOR COLOUR COMBINATIONS

STANDARD

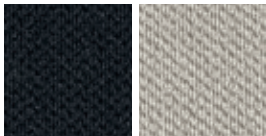
①	②	③	④	⑤	⑥
DUOTONE SEAT WITH CONTRAST STITCH	 veneer	HEADLINING MORZINE*	UPPER FACIA WITH CONTRAST STITCH	FINISHER	CARPETS
					
Jet/Jet with Light Oyster	Grey Figured Ebony	Jet or Light Oyster**	Jet with Light Oyster	Dark Hex Aluminium	Jet
					
Red/Jet with Jet	Grey Figured Ebony	Jet or Light Oyster**	Jet with Red	Dark Hex Aluminium	Jet

veneER OPTIONS

Gloss Black Veneer, Carbon Fibre Veneer, Satin Ash Burl Veneer, Gloss Figured Ebony Veneer, Satin Fine Line Veneer, Satin Rosewood Veneer or Gloss Burr Walnut Veneer

*Suedecloth headlining available as an option.
**Light Oyster headlining available as an option.

5 CHOOSE YOUR INTERIOR

Configure your vehicle at jaguar-me.com



















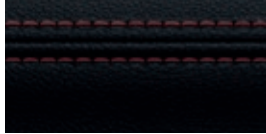

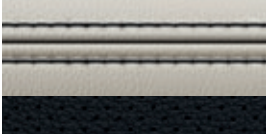
Interior shown: Light Oyster and Jet perforated Taurus leather Sports seats with Jet contrast stitch, Jet fascia with Light Oyster contrast stitch, Dark Hex Aluminium finisher, Grey Figured Ebony veneer and Jet headlining.

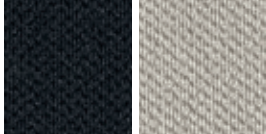
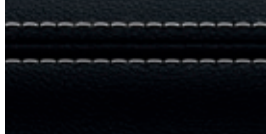

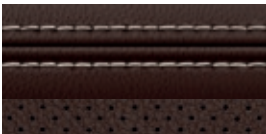
S

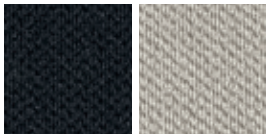
INTERIOR COLOUR COMBINATIONS

OPTIONS

1	2	3	4	5	6
<p>DUOTONE SEAT WITH CONTRAST STITCH</p>  <p>Jet/Jet with Light Oyster</p>	<p>VENEER</p>  <p>Grey Figured Ebony</p>	<p>HEADLINING MORZINE*</p>  <p>Jet or Light Oyster**</p>	<p>UPPER FACIA WITH CONTRAST STITCH</p>  <p>Jet with Light Oyster</p>	<p>FINISHER</p>  <p>Dark Hex Aluminium</p>	<p>CARPETS</p>  <p>Jet</p>
 <p>Red/Jet with Jet</p>	 <p>Grey Figured Ebony</p>	 <p>Jet or Light Oyster**</p>	 <p>Jet with Red</p>	 <p>Dark Hex Aluminium</p>	 <p>Jet</p>
 <p>Light Oyster/Jet with Jet</p>	 <p>Grey Figured Ebony</p>	 <p>Jet or Light Oyster**</p>	 <p>Jet with Light Oyster</p>	 <p>Dark Hex Aluminium</p>	 <p>Jet</p>
 <p>Brogue/Brogue with Light Oyster</p>	 <p>Grey Figured Ebony</p>	 <p>Jet or Light Oyster**</p>	 <p>Jet with Light Oyster</p>	 <p>Dark Hex Aluminium</p>	 <p>Jet</p>

VENEER OPTIONS

Gloss Black Veneer, Carbon Fibre Veneer, Satin Ash Burl Veneer, Gloss Figured Ebony Veneer, Satin Fine Line Veneer, Satin Rosewood Veneer or Gloss Burr Walnut Veneer

*Suedecloth headlining available as an option.
 **Light Oyster headlining available as an option.

5 CHOOSE YOUR INTERIOR

 Configure your vehicle at [jaguar-me.com](https://www.jaguar-me.com)

Gloss Black Veneer

Carbon Fibre Veneer

Satin Ash Burl Veneer

Gloss Figured Ebony Veneer

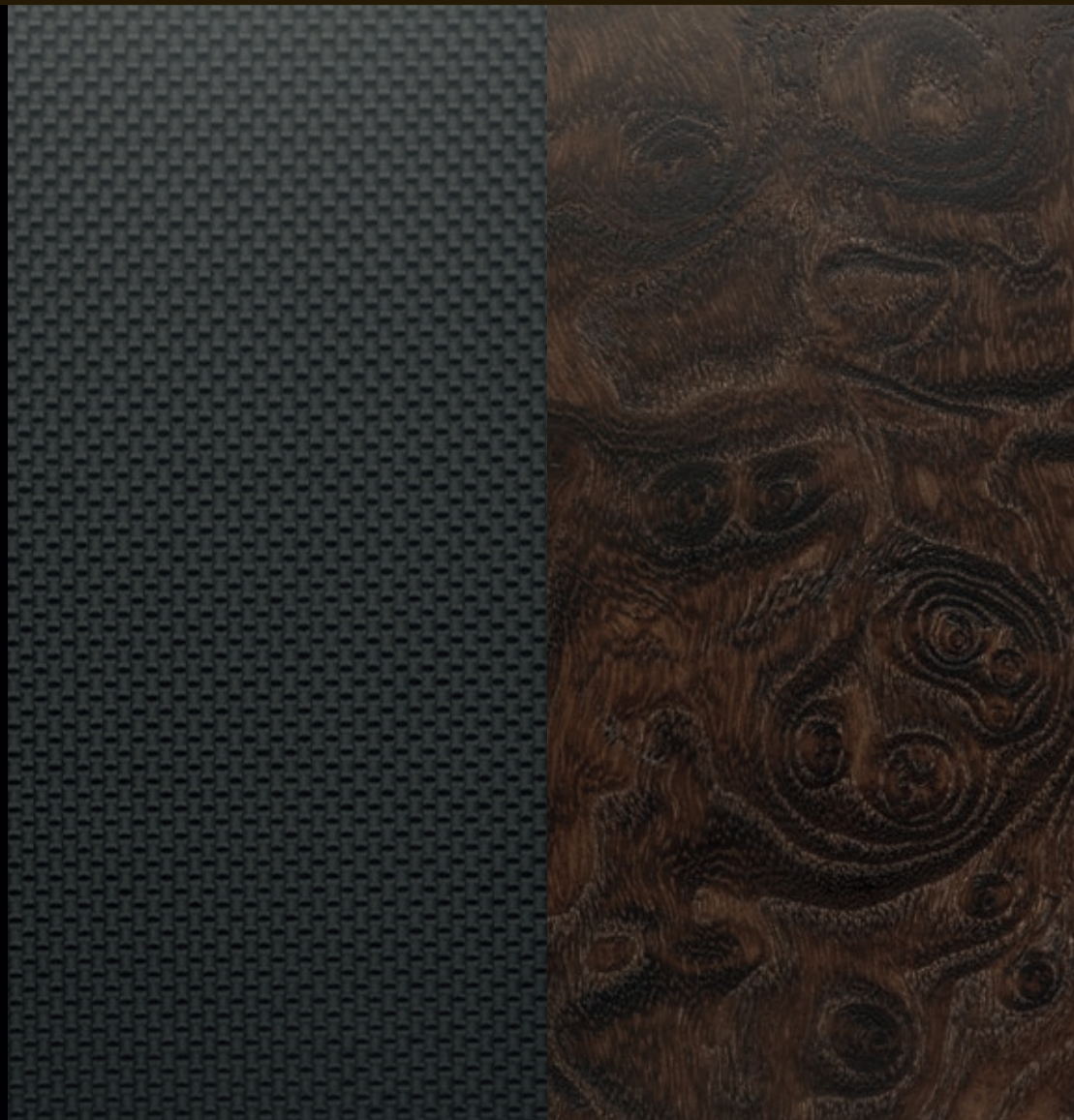

Grey Figured Ebony Veneer



Satin Fine Line Veneer



Satin Rosewood Veneer



Gloss Burr Walnut Veneer

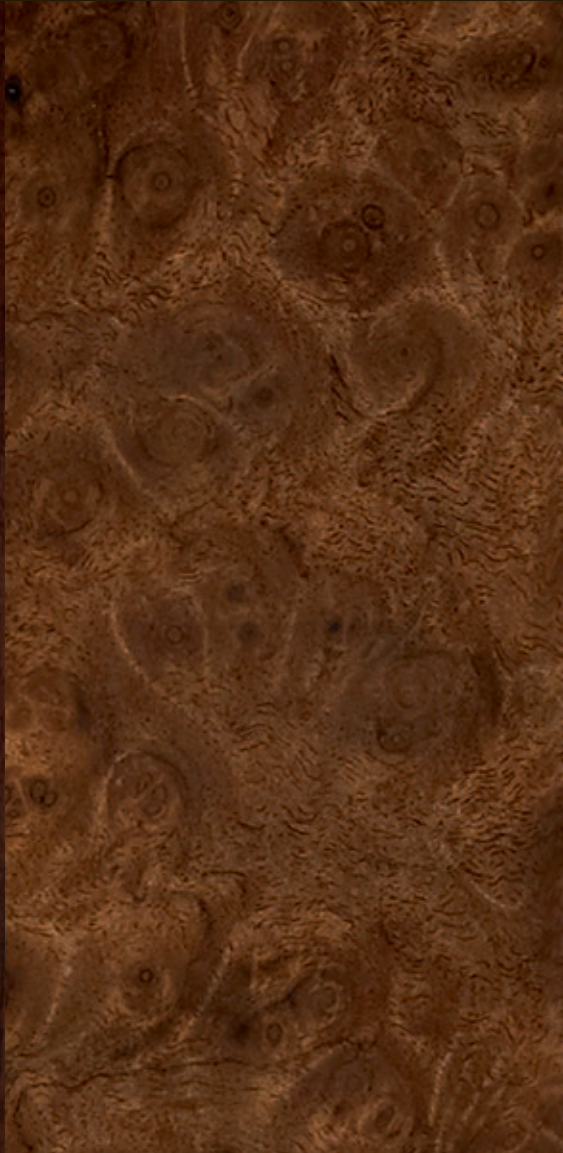

6 CHOOSE YOUR JAGUAR ACCESSORIES

To find out more about the full range of retailer fit Jaguar Accessories, please refer to your retailer or go to accessories.jaguar.com

Gloss Black Side Vent



Aluminium Paddle Shifters



Premium Carpet Mats

Rubber Mats



Gloss Black Mirror Caps



JaguarDrive Selector –
Black Leather Top



iPad Holder



Roof Cross Bars



Roof Sports Box



Illuminated Sill Tread Plates



TECHNICAL SPECIFICATIONS

 Configure your vehicle at jaguar-me.com

ENGINES		20d 2.0 LITRE i4 TURBOCHARGED DIESEL* [AUTO]	30d 3.0 LITRE V6 TWIN TURBOCHARGED DIESEL* [AUTO]
Capacity	cc	1,999	2,993
Maximum power	EEC-PS (kW)	180 (132)	300 (221)
@rev/min	rpm	4,000	4,000
Maximum torque	EEC-Nm (lb.ft.)	430	700
@rev/min	rpm	1,750-2,500	2,000
PERFORMANCE		RWD	RWD
0-100 km/h	seconds	8.1	6.2
0-60 mph	seconds	7.7	5.8
Top speed	km/h (mph)	229 (142)	250 (155)
FUEL CONSUMPTION ¹			
Urban	l/100km (mpg)	5.1 (54.3)	6.6 (42.8)
Extra Urban	l/100km (mpg)	3.8 (74.3)	4.8 (58.9)
Combined	l/100km (mpg)	4.3 (65.7)	5.5 (51.4)
Carbon dioxide emissions	g/km	114	144
Tank capacity (usable)	ltr approx.	66	66
DIMENSIONS			
Overall length	mm	4,954	4,954
Overall width (inc. mirrors)	mm	2,091	2,091
Overall width (exc. mirrors)	mm	1,880	1,880
Overall height	mm	1,457	1,457
Wheelbase	mm	2,960	2,960
Front track	mm	1,605 (1,597 20" wheels)	1,605 (1,597 20" wheels)
Rear track	mm	1,594 (1,586 20" wheels)	1,594 (1,586 20" wheels)
Ground clearance	mm	116	110
Turning circle diameter (kerb to kerb)	m	11.61	11.61
Boot volume	litres	540	540
WEIGHT ²			
Kerb weight from	kg	1,595	1,750
Gross vehicle weight	kg	2,250	2,350
ENGINE AVAILABILITY			
Pure		●	—
Prestige		●	—
Portfolio		—	—
R-Sport		●	—
S		—	●

● Available — Not Available

¹The figures provided are as a result of official manufacturer's tests in accordance with EU legislation. A vehicle's actual fuel consumption may differ from that achieved in such tests and these figures are for comparative purposes only.

²Weights reflect vehicles to standard specifications. Optional extras increase weight.

ENGINES		25t JAGUAR 2.0 LITRE i4 240 TURBOCHARGED PETROL [AUTO]	35t 3.0 LITRE V6 SUPERCHARGED PETROL [AUTO]	S 3.0 LITRE V6 SUPERCHARGED PETROL [AUTO]
Capacity	cc	1,999	2,995	2,995
Maximum power	EEC-PS (kW)	240 (177)	340 (250)	380 (280)
@rev/min	rpm	5,500	6,500	6,500
Maximum torque	EEC-Nm (lb.ft.)	340	450	450
@rev/min	rpm	1,750-4,000	4,500	4,500
PERFORMANCE		RWD	RWD	RWD
0-100 km/h	seconds	7.0	5.4	5.3
0-60 mph	seconds	6.7	5.2	5.1
Top speed	km/h (mph)	248 (154)	250 (155)	250 (155)
FUEL CONSUMPTION ¹				
Urban	l/100km (mpg)	10.5 (26.9)	11.7 (24.1)	11.7 (24.1)
Extra Urban	l/100km (mpg)	5.8 (48.7)	6.3 (44.8)	6.3 (44.8)
Combined	l/100km (mpg)	7.5 (37.7)	8.3 (34.0)	8.3 (34.0)
Carbon dioxide emissions	g/km	179	198	198
Tank capacity (usable)	ltr approx.	74	74	74
DIMENSIONS				
Overall length	mm	4,954	4,954	4,954
Overall width (inc. mirrors)	mm	2,091	2,091	2,091
Overall width (exc. mirrors)	mm	1,880	1,880	1,880
Overall height	mm	1,457	1,457	1,457
Wheelbase	mm	2,960	2,960	2,960
Front track	mm	1,605 (1,597 20" wheels)	1,605 (1,597 20" wheels)	1,605 (1,597 20" wheels)
Rear track	mm	1,594 (1,586 20" wheels)	1,594 (1,586 20" wheels)	1,594 (1,586 20" wheels)
Ground clearance	mm	116	116	116
Turning circle diameter (kerb to kerb)	m	11.61	11.61	11.61
Boot volume	litres	540	540	540
WEIGHT ²				
Kerb weight from	kg	1,590	1,710	1,710
Gross vehicle weight	kg	2,210	2,330	2,330
ENGINE AVAILABILITY				
Pure		●	—	—
Prestige		●	●	—
Portfolio		●	●	—
R-Sport		●	●	—
S		—	—	●

DIMENSIONS

Overall Width (inc mirrors) 2,091mm

Overall Width (exc mirrors) 1,880mm

Boot Volume 540 Litres

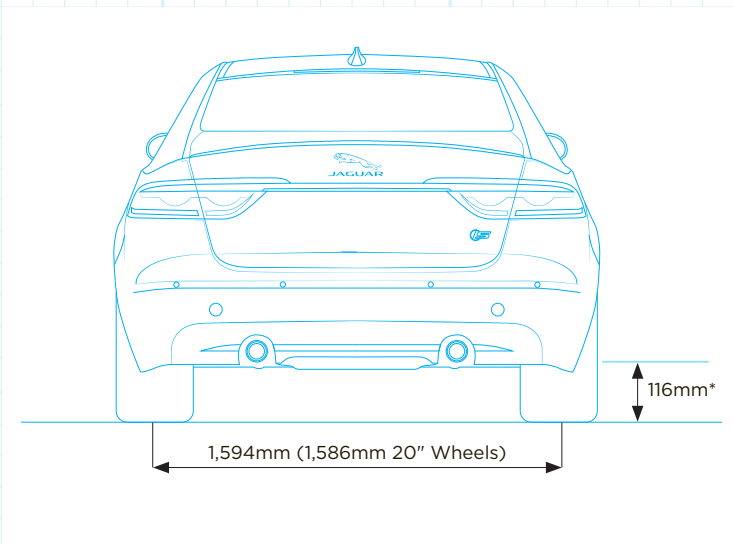
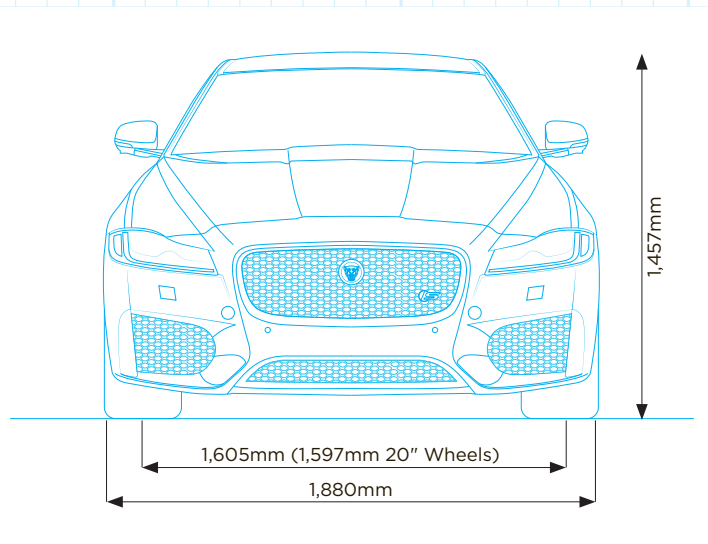

Turning Circle

Kerb to Kerb 11.61m
Wall to Wall 11.94m

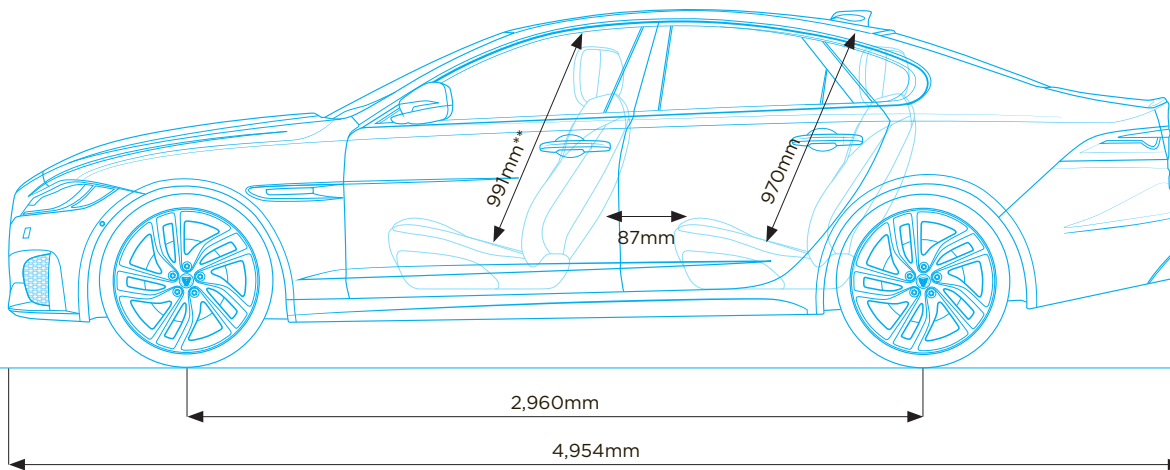
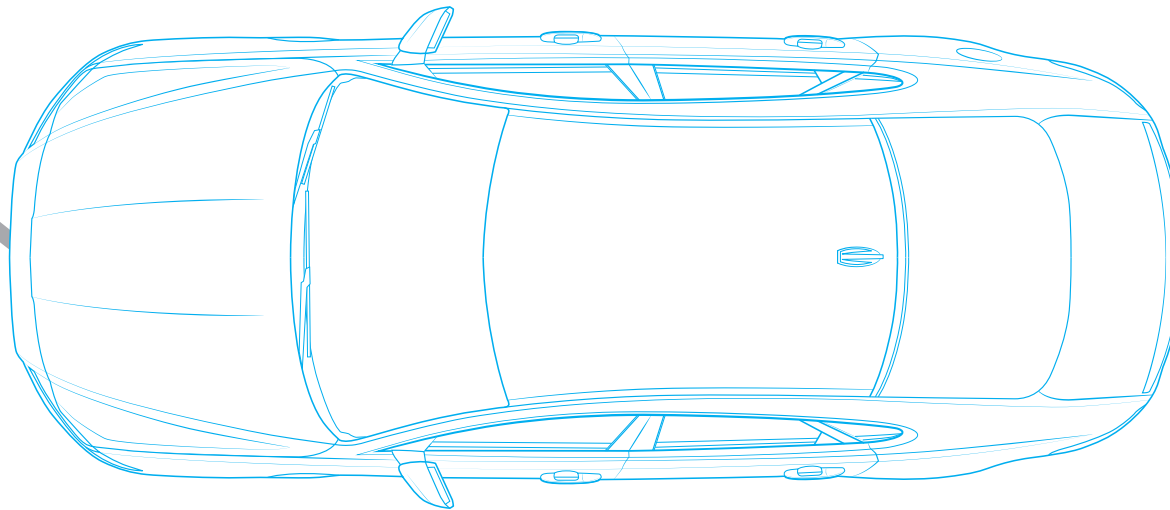

*110mm for 30d 3.0 litre V6 twin turbocharged diesel.
**953mm with optional sunroof.
Dimensions were measured with vehicle at unladen weight.
(measured by VDA standard test method using 200 x 100 x 50mm blocks.)



JAGUAR EXPERIENCE

There's no better way to get to know XF and Jaguar than by taking a drive. Jaguar Experience offers a range of unique opportunities to really find out what it feels like to get the most out of a Jaguar. Our track experiences allow you to push yourself, XF and other cars from the incredible Jaguar range to the limit. Jaguar Experience also offers the opportunity to see a Jaguar brought to life during a tour of one of our UK manufacturing facilities. Find out more by visiting jaguar-me.com

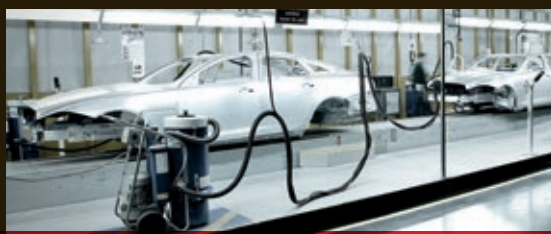

Follow us on:



Facebook.com



Instagram.com



Twitter.com



Youtube.com

THE WORLD OF JAGUAR

Choose an XF and you're joining the exciting World of Jaguar. It makes owning and driving carefree and easy, as well as providing a range of exclusive services and lifestyle products.



SERVICING

XF has been designed to keep servicing costs to a minimum - for example, the new Ingenium diesel* engines can achieve an incredible 34,000km or 2 years* between services due to intelligent design and advanced oil technology.

GENUINE PARTS

Jaguar Genuine Parts are designed, tested and manufactured to our uncompromising standards for quality, fit and durability. Each part is engineered specifically for your XF to contribute to optimum performance and to help maximise its lifespan.



FLEET & BUSINESS

Jaguar is dedicated to being the premium manufacturer of choice for fleets and businesses by providing a highly attractive car range and exemplary customer service. Jaguars are dynamic and distinctive cars that help companies express the unique character and personality of their business. We are committed to providing totally customer-focused aftersales services, which keeps every Jaguar car on the move and in top condition, ensuring that they perform to the highest standard and in the most cost-efficient way for businesses, visit jaguar-me.com

*Market and driving style dependent.
*Manufacturer's estimate.



JAGUAR FINANCIAL SERVICES

Effortless performance and style come as standard with every Jaguar. Jaguar Financial Services makes buying one just as simple and rewarding. New or used, for personal or business use, we have an option that puts you in complete control. Please speak to your local Jaguar retailer to find out more.



JAGUAR ASSISTANCE

Jaguar Assistance provides assistance in motoring emergencies, from immobilisation due to breakdown or accident to minor problems such as punctures. You can rely on our roadside assistance, whatever the situation, wherever you happen to be.

LOW INSURANCE

XF's key components are easily accessible for time-efficient service and repair and to minimise scheduled maintenance and repair costs. With a focus on lower repair costs, XF delivers competitive insurance group ratings[†]. To find out more about the compelling business case for XF, please contact your local Jaguar retailer.



JAGUAR MAGAZINE

Jaguar Magazine is the official magazine of Jaguar Cars. It features the new Jaguar F-TYPE, XJ, XE and XF, and the worlds of luxury, style, design and travel.

JAGUAR COLLECTION

The latest range from the Jaguar Collection has been crafted with the same design execution and attention to detail that goes into all of our cars. This is evident in our clothing range, premium leather items and luxury travel goods. To celebrate Jaguar's heritage we also have a collection that honours past achievements and features race inspired gift items and apparel. To find out more, visit the online shop at jaguar.com/shop

*Market and driving style dependent.
[†]Manufacturer's estimate.

GLOSSARY

A

ADAPTIVE FULL LED HEADLIGHTS

Adaptive Headlights automatically adjust to follow steering inputs, casting light where needed. They will angle the beam when indicating, as well as working in conjunction with Automatic High Beam Assist to prevent your lights from dazzling oncoming traffic.

ADAPTIVE SPEED LIMITER

The Adaptive Speed Limiter, when selected, will assist in limiting vehicle speed to the speed limits as recognised by the Traffic Sign Recognition system.

ADVANCED PARK ASSIST

Advanced Park Assist offers all the functions of Park Assist (see pg. 50) plus 360° Park Distance Control with virtual object tracking. This gives confidence in confined situations, at speeds up to 16km/h.

AUX CONNECTION

Auxiliary (AUX) connections allow for the convenient input of audio signals from personal devices.

C

Cd.

The Cd. value is the drag coefficient of the car. It gives an indication of the vehicle's aerodynamic qualities. The lower the value, the more aerodynamically efficient the vehicle's design.

CONFIGURABLE INTERIOR MOOD LIGHTING

Configurable Interior Mood Lighting highlights a number of your Jaguar's key functional and styling features and allows adjustment of the ambient light. Choose from a range of 10 colours.

CONNECTIVITY PACKAGE

A connectivity package is a bundle of applications and technologies that enhances your connection with your Jaguar and with the world by giving internet connectivity, optimised in-car applications and remote access to your car.

D

DAMPERS/DAMPING

Dampers absorb forces acting on the suspension for greater ride comfort and control. Dampers are also known as shock absorbers.

DEAD RECKONING

Dead Reckoning uses sensors to measure vehicle direction, wheel rotation and inclination. These measurements are calibrated up to 40 times per second to ensure accurate placement of the vehicle even when no GPS signal is available.

DRAG COEFFICIENT

The drag coefficient measures how aerodynamic a car is. See definition of Cd.

E

ECO MODE

Eco Mode encourages fuel efficient driving by reducing throttle sensitivity, selecting more economical engine mapping and, on manual vehicles, advising of gearshifts. It also reduces fuel consumption by reducing the energy demands placed on the engine by climate control and audio systems.

F

FORWARD ALERT

Should a potential collision be detected Forward Alert gives an audible warning and a visual warning in the instrument cluster.

FOUR-ZONE CLIMATE CONTROL

Automatic four-zone climate control that can be optimised for individual occupants.

G

GPS

The Global Positioning System (GPS) uses satellites to determine the car's position. By cross-referencing this with road maps stored in its memory, the navigation system provides route guidance and tracks the car's location.

I

INGENIUM ENGINES

Ingenium engines are manufactured in the UK at Jaguar Land Rover's state-of-the-art Engine Manufacturing Centre in the West Midlands. The aluminium engines feature lightweight construction, with stiff cylinder blocks and decoupled injectors, which ensure low levels of vibration and noise intrusion, further enhancing the driver experience. A series of advanced technologies reduce internal friction, improve refinement and enhance overall performance. In addition, Selective Catalytic Reduction and a new low-pressure exhaust gas recirculation system significantly reduce both CO₂ and NOx emissions on diesel engines.

INTERIOR MOOD LIGHTING

Interior mood lighting highlights many of the cabin's key features and design details in a relaxing soft phosphor blue glow.

INTELLIGENT STOP/START

Stop/Start is a technology that stops the engine when it is not needed, improving the fuel economy and reducing the car's CO₂ emissions. The engine will restart as soon as the driver's foot comes off the brake pedal. The engine will be operating at full capacity before the driver's foot has touched the accelerator pedal.

J

JAGUAR SIGNATURE 'J' BLADE DAYTIME RUNNING LIGHTS

J-Blade Daytime Running Lights are separate LED running lights, in a distinctive 'J' shape, built into the headlights. They emphasise Jaguar's striking on road style.

JAGUARDRIVE CONTROL

Interacts with the Dynamic Stability Control system, engine and transmission management systems to alter the characteristics of the engine mapping, gearshifts and brakes. It offers different modes designed to optimise the vehicle's response to particular driving conditions and styles.

JAGUARDRIVE SELECTOR

The JaguarDrive Selector rises from the centre console on start up. It is a rotary shifter used with automatic transmissions that allows you to quickly shift between drive modes.

L

LED HEADLIGHTS WITH LED 'J' BLADE DAYTIME RUNNING LIGHTS

Multiple powerful LED emitters give a clearer light in low light conditions. Further complemented with LED J-Blade Daytime Running Lights incorporating LED Direction Indicators. These lights also integrate Jaguar's Adaptive Lighting and Auto High Beam Assist systems.

M

MHL CONNECTION

A Mobile High-Definition Link (MHL) enables connection between a personal device and the InControl infotainment system. It is designed for seamless transfer of audio-visual data.

10.2 INCH MULTI-TOUCH DISPLAY

The Multi-touch functionality of InControl Touch Pro's 10.2 inch Display allows the screen to recognise multiple points of contact. This provides direct control of the system's features in a more natural, intuitive way, enabling gestures such as pinch and zoom.



S

SATELLITE VIEW

Satellite View allows you to view satellite imagery as an optional view mode for the navigation system.

SD CARD

A Secure Digital (SD) Card is a flash memory card used for storing large amounts of data in a compact form.

SOLID STATE DRIVE

Solid State Drives are storage devices with no moving parts designed for rapid retrieval of large quantities of data.

V

12.3 INCH VIRTUAL INSTRUMENT DISPLAY

The 12.3 inch Virtual Instrument Display is a TFT (Thin Film Transistor) screen that replaces the traditional instrument cluster. It displays a wide range of key driving information. Four graphical themes and a 3D map view are available.

W

WINTER MODE

By selecting Winter Mode, the system automatically dampens acceleration and applies more gradual torque for improved traction in slippery conditions.

X

XENON HEADLIGHTS

Bi-function Xenon headlights offer improved illumination and feature LED J-Blade Daytime Running Lights for a striking on road style.

Meridian is the registered trademark of Meridian Audio Limited.

The Bluetooth® word mark and logos are owned by the Bluetooth SIG, Inc. and any use of such marks by Jaguar Land Rover Limited is under licence.

iPod, iPod touch and iPad are trademarks of Apple Inc, registered in the US and other countries.

IMPORTANT NOTICE

Jaguar Land Rover Limited is constantly seeking ways to improve the specification, design and production of its vehicles and alterations take place continually. While every effort is made to produce up-to-date literature, this brochure should not be regarded as an infallible guide to current specifications, nor does it constitute an offer for the sale of any particular vehicle. Distributors and Retailers are not agents of Jaguar Land Rover Limited by any express or implied undertaking or representation. Comparisons are based on manufacturer's own data and testing.

COLOURS

Print and online colours are representative only.

ENVIRONMENTAL INNOVATION AT JAGUAR

Jaguar is proud to continue the company's tradition with its approach to Environmental Innovation. From the choice of lightweight materials and lean production methods to the efficiency of its engines and designs, Jaguar is committed to operating as a more sustainable business and reducing its overall environmental impact.

Jaguar's flagship XJ model was the first in the company to achieve ISO14040, the international standard for vehicle 'life cycle assessment'. This certification measures the environmental impact of XJ from component material sourcing and manufacturing process, through driving 200,000 km. But that's not all. Every new Jaguar is designed to be 85% Recyclable/Reusable and 95% Recoverable at the end of the vehicle's life.

The all-new XF, XE, XJ and F-TYPE's innovative use of lightweight aluminium, which incorporates up to 50% closed-loop recycled material from the manufacturing process of the body structures, provides considerable performance benefits. This includes improved fuel consumption and less CO₂ emissions during the use phase of the Life Cycle due to lighter structures. Our on-going target is to ensure scrap aluminium reclaimed from our stamping process is to be segregated and recycled through a closed loop system and re-melted into the same grade quality sheet, therefore reducing CO₂ emissions during the production phase of the Life Cycle. Jaguar is committed to reducing dependency on fossil fuels, using fewer resources and creating less waste as part of our approach to sustainability excellence.

The company plan includes 25% reduction targets in operating and tailpipe CO₂ emissions, waste to landfill, logistics efficiencies (15%) and water consumption (10%), all based on per vehicle built since 2007. In addition the manufacturing assembly CO₂ emissions of each Jaguar built in the UK since 2009 is 100% offset. For each tonne of CO₂ emitted in the assembly process, Jaguar invests in projects that reduce an equivalent tonne of CO₂ elsewhere. Taking into account the company's global sales growth and increased investment in more efficient operating facilities, we are proud to have delivered and in some cases exceeded our Environmental Innovation targets as planned for 2012. And we are on track to meet our 25% reduction in joint European fleet average tailpipe CO₂ emissions by 2015.

Looking forward, we have developed our 2020 vision for sustainable business growth that focuses on continued improvements in tailpipe CO₂ emissions, operational carbon neutrality and zero waste. To date the company has offset over 6 million tonnes of CO₂, provided over 4,000 direct jobs in 60 emissions reduction projects in 17 countries and improved the lives of over 1 million people in our global cook stoves emissions reduction programme.

But it doesn't stop there. Our manufacturing facilities have been certified to ISO14001 since 1998 and we are credited to Platinum Plus level in the UK's Business in the Community Corporate Responsibility Index.

Castrol EDGE™ Professional is exclusively recommended by Jaguar.

Jaguar Land Rover Limited
Registered Office: Floor 7, Wing E,
HQ Building, Dubai Silicon Oasis,
P.O. Box 32588, Dubai UAE
Registered in England Number: 1672070
jaguar-me.com

November 2015/16MY
JLM/39/02/30/1115

VEHICLE SHOWN FRONT AND BACK COVERS: XF S IN GLACIER WHITE WITH 20" LABYRINTH ALLOY WHEELS, OPTIONAL LED HEADLIGHTS AND OPTIONAL BLACK PACK

