

TITAN FLOW CONTROL, INC.

*Your Pipeline
to the Future!*

Visit us online at: www.titanfci.com

product lines

- Y Strainers
- Basket Strainers
- Duplex Strainers
- Check Valves
- Butterfly Valves
- Ball Valves
- Fabricated Products
- Specialty Products
- Pump Protection

contact information

Titan Flow Control, Inc.
290 Corporate Drive
Lumberton, NC 28358

T: 910.735.0000
F: 910.738.3848
titan@titanfci.com





290 CORPORATE DRIVE
LUMBERTON, NC 28358

WWW.TITANFCI.COM
TITAN@TITANFCI.COM

910.735.0000 TEL
910.738.3848 FAX

PRODUCT GUIDE



**GO
WITH
THE
FLOW!**

***TITAN FLOW CONTROL, INC.
YOUR PIPELINE TO THE FUTURE!***

Titan Flow Control is a high quality manufacturer of Check Valves, Butterfly Valves, Pipeline Strainers, Pump Products, Fabricated Designs, and Pipeline accessories applicable to most industrial and commercial requirements. Titan Flow Control was established in the year 2000 by industry veterans with over 300 years of combined experience. We are located in the southeastern part of North Carolina and currently occupy over 70,000 ft² of office, warehouse, and manufacturing space.

- | | | |
|------------------------|----------------------------|-----------------------|
| • "Y" STRAINERS | • "T" STRAINERS | • BALL VALVES |
| • BASKET STRAINERS | • IN-LINE CHECK VALVES | • BUTTERFLY VALVES |
| • DUPLEX STRAINERS | • SILENT CHECK VALVES | • SUCTION DIFFUSERS |
| • STRAINING ELEMENTS | • WAFER TYPE CHECK VALVES | • TRI-FLOW VALVES |
| • FRP STRAINERS | • GLOBE TYPE CHECK VALVES | • FOOT VALVES |
| • TEMPORARY STRAINERS | • SINGLE DISC CHECK VALVES | • AUTOMATIC STRAINERS |
| • FABRICATED STRAINERS | • DUAL DISC CHECK VALVES | • AND MUCH MORE... |

TELEPHONE: 910.735.0000

TITAN FLOW CONTROL, INC.

"Y" Type Strainers

Cast Iron



YS 12-CI
Class 250
Threaded
Sizes: 1/4 ~ 3"



YS 58-CI
Class 125
Flanged
Sizes: 2 ~ 24"



YS 59-CI
Class 250
Flanged
Sizes: 2 ~ 12"

**Need a strainer?
...It's a no-brainer!**

We routinely stock:

- Sizes 1/4" through 24"
- Pressure Classes 125 ~ 2500
- Standard materials
- Exotic materials
- All end connections

If we don't have it - we'll help you find it!

Bronze & Brass



YS 55-BR
YS 55-BZ
Class 125
Threaded
Sizes: 1/4 ~ 3"



YS 56-BR
YS 56-BZ
Class 125
Solder
Sizes: 1/4 ~ 3"



YS 52-AB
Class 250
Threaded
Sizes: 1/4 ~ 3"



YS 54-AB
Class 150
Flanged
Sizes: 2 ~ 12"

Lead Free!*
(See note on the following page)

Carbon & Stainless Steel

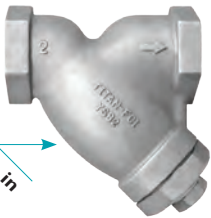

Available in
WC6
Alloy 20
316L

YS 81-CS
YS 81-SS
Class 600
Threaded
Sizes: 1/4 ~ 3"

YS 82-CS
YS 82-SS
Class 600
Socket Weld
Sizes: 1/4 ~ 3"

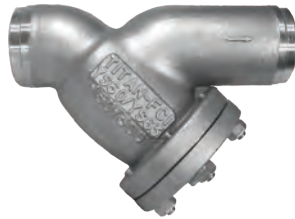

YS 63-CS
YS 63-SS
Class 300
Butt Weld
Sizes: 1/2 ~ 12"



YS 65-CS
YS 65-SS
Class 600
Butt Weld
Sizes: 1/2 ~ 12"

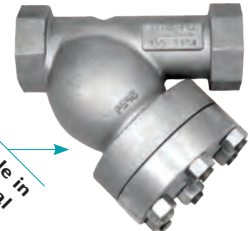

YS 83-CS
YS 83-SS
Class 1500
Threaded
Sizes: 1/2 ~ 3"

YS 84-CS
YS 84-SS
Class 1500
Socket Weld
Sizes: 1/2 ~ 3"

Available in
Additional
Materials



YS 61-CS
YS 61-SS
Class 150
Flanged
Sizes: 1/2 ~ 24"



YS 62-CS
YS 62-SS
Class 300
Flanged
Sizes: 1/2 ~ 12"



YS 64-CS
YS 64-SS
Class 600
Flanged
Sizes: 1/2 ~ 12"

**High Pressure
Models Available**

YS 68-CS
YS 68-SS
Class 1500
Flanged
Sizes: 2 ~ 8"



YS 69-CS
YS 69-SS
Class 1500
Butt Weld
Sizes: 2 ~ 8"

YS 70-CS
YS 70-SS
Class 2500
Flanged
Sizes: 2 ~ 8"

YS 71-CS
YS 71-SS
Class 2500
Butt Weld
Sizes: 1 1/2 ~ 10"

TITAN FLOW CONTROL, INC.

Basket Strainers (Simplex)

Cast Iron



BS 25-CI
Class 125
Threaded
Quick-Open Cover
Sizes: $\frac{3}{8}$ " ~ 3"



BS 25F-CI
Class 125
Flanged
Quick-Open Cover
Sizes: 1 ~ 8"



BS 55-CI
Class 125
Flanged
Clamp Cover
Sizes: 2 ~ 12"

Available with
bolted and
clamped cover



BS 65-CI
Class 125
Flanged
Bolted Cover
Sizes: 2 ~ 12"

Carbon & Stainless Steel



BS 35-CS
BS 35-SS
Class 150/300
Threaded
Sizes: $\frac{3}{8}$ " ~ 3"



BS 35F-CS
BS 35F-SS
Class 150
Flanged
Sizes: 1 ~ 8"



BS 85-CS
BS 85-SS
Class 150
Flanged
Sizes: 2 ~ 12"

Available with
bolted and
clamped cover



BS 86-CS
BS 86-SS
Class 300
Flanged
Sizes: 2 ~ 12"

Fiberglass & Aluminum Bronze



BS 55-FRP
Class 150
Flanged
Sizes: 4 ~ 20"



BS 95-AB
Class 150
Flanged
Sizes: 2 ~ 12"

Lead Free!*

* The YS52-AB, YS54-AB, BS55-FRP, & BS95-AB, meet the requirements for **Lead Free** use in potable water systems. The lead content in the wetted surfaces of these products is 0.25% or less as determined by a weighted average. For more information on lead free requirements, contact Titan Flow Control, Inc.

Optional Cover Designs

Most Basket Strainer models can be constructed with various cover designs including bolted, clamped, and hinged.



BS 25-CI
Quick-Opening -
Knob Type Cover
Sizes: $\frac{3}{8}$ " ~ 3"

BS 85-CS
Full Rated -
Clamped Cover
Sizes: 2 ~ 12"



TITAN FLOW CONTROL, INC.

Duplex Strainers



Cast Iron



DS 595-CI

Class 125
Threaded
Cast Iron
Sizes: 3/4 ~ 2 1/2"

DS 695-CI

Class 125
Flanged
Cast Iron
Sizes: 1 ~ 4"

Stainless & Carbon Steel



DS 596-CS DS 596-SS

Class 150
Threaded
Carbon Steel
Stainless Steel
Sizes: 3/4 ~ 2 1/2"

DS 696-CS DS 696-SS

Class 150
Flanged
Carbon Steel
Stainless Steel
Sizes: 1 ~ 4"

Aluminum Bronze



DS 596-AB

Class 150
Threaded
Aluminum
Bronze
Sizes: 3/4 ~ 2 1/2"

DS 696-AB

Class 150
Flanged
Aluminum
Bronze
Sizes: 1 ~ 4"

Pump Products



Tri-Flow Valve TF 21-CI

Class 125
Flanged
Cast Iron
Sizes: 2 ~ 20"



Foot Valve FV 50-DI

Class 150
Flanged
Ductile Iron
Sizes: 2 ~ 12"

Ball Valves



BV 25-SS

Male x Female
3000 WOG
Full Port Sizes: 1/4 ~ 1 1/2"
Reduced Port Size: 2"



BV 60-BZ

600 WOG
Male x Female
Full Port Design
Sizes: 1/4 ~ 2"



Suction Diffuser SD 22-CI

Class 125
Flanged
Cast Iron
Sizes: 2 x 1 1/4 ~ 18 x 18"



Blow-off Valves

Ball Valves can be professionally installed as Blow-off Valves at our factory before shipping.

Foot Valves

Check Valve Models CV 80-SS and CV 20-BZ can also be designed as Foot Valves



TITAN FLOW CONTROL, INC.

Check Valves

Center Guided



Available with soft and metal seats

CV 90-DI
Class 150/300
Wafer Type - Silent
Ductile Iron
Sizes: 2 ~ 12"



Available with soft and metal seats

CV 91-SS
Class 150/300
Wafer Type - Silent
Stainless Steel
Sizes: 2 ~ 12"



CV 80-SS
Class 300
Threaded / In-Line
Stainless Steel
Sizes: $\frac{3}{8}$ ~ 3"



CV 20-BR
400 WOG
Threaded / In-Line
Brass
Sizes: $\frac{1}{4}$ ~ 2"



Available with soft and metal seats

CV 50-DI
Class 150
Flanged - Globe Style
Ductile Iron
Sizes: 2 ~ 36"



Available with soft and metal seats

CV 51-CS / CV 51-SS
Class 150
Flanged - Globe Style
Carbon & Stainless Steel
Sizes: 2 ~ 36"



Available with soft and metal seats

CV 52-DI
CV 52-CS / CV 52-SS
Class 300
Flanged - Globe Style
Ductile Iron, Carbon & Stainless
Sizes: 2 ~ 36"

Single & Dual Disc



CV 12-CS / CV 12-SS
Class 150
Short Pattern - Wafer Type
Carbon & Stainless Steel
Sizes: 2 ~ 24"



CV 31-DI
Class 150
Wafer - Swing Type
Ductile Iron
Sizes: 2 ~ 12"



CV 32-CS / CV 32-SS
Class 150
Wafer - Swing Type
Carbon & Stainless Steel
Sizes: 2 ~ 12"



CV 41-DI
Class 150
Wafer - Dual Disc
Ductile Iron
Sizes: 2 ~ 48"



CV 42-CS / CV 42-SS
Class 150/300
Wafer - Dual Disc
Carbon & Stainless Steel
Sizes: 2 ~ 48"



CV 44-CS / CV 44-SS
Class 300
Wafer - Dual Disc
Carbon & Stainless Steel
Sizes: 2 ~ 48"



CV 46-CS / CV 46-SS
CV 47-CS / CV 47-SS
Class 600 & 900
Wafer - Dual Disc
Carbon & Stainless Steel
Sizes: 2 ~ 48"

**Lead Free*
Trim on Titan
Check Valves**

* Titan's Check Valves have either Stainless Steel or Aluminum Bronze trim to meet the requirements for **Lead Free** use in potable water systems. The lead content of the wetted surfaces of Titan's iron and steel check valve models is 0.25% or less as determined by a weighted average. For more information on lead free requirements, contact Titan Flow Control, Inc.

TITAN FLOW CONTROL, INC.

Butterfly Valves & Actuation



Cast & Ductile Iron



BF 75-CI
200 PSI
Wafer Type
Cast Iron
Sizes: 2 ~ 48"



BF 76-DI
200 PSI
Lug Type
Ductile Iron
Sizes: 2 ~ 48"

Butterfly Valve Features:

- Seat is Phenolic Backed Cartridge
- Sizes 2" through 12" in Stock
- Valve Bodies are Epoxy Painted
- Rated for 200 psi Bidirectional Service
- Extended Neck provides 2" of Piping Clearance
- Alignment Holes for easy Installation
- Designed in Accordance with ASME/ANSI Class 125/150
- When ordered with Aluminum Bronze discs, Titan Butterfly Valves meet the requirements for **Lead Free** use in potable water systems. The lead content in the wetted surfaces of Titan Butterfly Valves with AB discs is 0.25% or less as determined by a weighted average. For more information on lead free requirements, contact Titan Flow Control, Inc.

Lead Free*
Butterfly Valve Discs Available!

Mounting Options

Butterfly Valves are available with 10-position, actuator, gear box, and chain wheel mounting. Stem Extensions are also available.



Chain Wheel



Gear Box

Universal Mounting Flange

The cast-in actuator flange is universally designed in accordance with ISO 5211 standard dimensions. The mounting flange can accommodate all types of operators such as: 10-position handle kits, gear operators, electric actuators, and pneumatic actuators. For actuators, Titan FCI may provide both direct mount and bracket mount designs. Please contact Titan FCI about your specific automation requirements.

Butterfly Valve Actuation

Titan FCI offers a complete line of Pneumatic Actuators and Electric Actuators.



Pneumatic Actuator with Travel Indicator



Electric Actuator for Sizes 3" & Smaller

Actuator Accessories:

- Three and Four-Way Direct Mount Solenoid Valves
- Pneumatic & Electro-Pneumatic Positioners
- Limit Switches
- Speed Controls
- Manual Override
- Lock Out Devices
- 4-20 MA and 3-15 PSI



Electric Actuator for Sizes 4" & Larger



Electric Actuator Mounting



Pneumatic Actuator Mounting

TITAN FLOW CONTROL, INC.

Fabricated Products

Fabricated Products

Titan FCI has the capability of designing and fabricating a variety of products to your exact specifications. Our fabricated products include:

- "Y" Strainers
- Duplex Strainers
- Steam Jacketed Strainers
- Fiberglass Reinforced Plastic Strainers
- And much more
- Basket Strainers
- Orifice Plates
- Temporary Strainers
- Spectacle Flanges
- Plate Strainers
- Single Blinds
- "T" Strainers
- Ring Spacers

Please contact the factory directly for any special projects or applications you may require.



Fabricated "Y" Strainer



Fabricated Basket Strainer



Fabricated Duplex Strainer

Replacement Screens & Baskets

Titan FCI can manufacture straining elements for all types of strainers including:

- "Y" Strainers
- "T" Strainers
- Basket Strainers
- Duplex Strainers

Titan FCI can manufacture straining elements in a wide variety of perforations, meshes, and materials (Type 304, Type 316, Alloy 20, Monel).

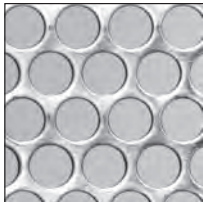

Perforated Screen



Wire Mesh with Perforated Backing

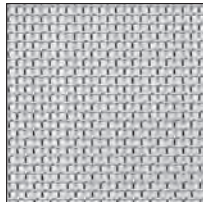

Wire Mesh

Temporary Strainers

Titan FCI can also manufacture Temporary / Conical Strainers.



Temporary Strainer 'Pilgrim's Hat' Type



Temporary Strainer 'Witch's Hat' Type

We can also provide replacement screens and baskets for our competitor's strainers.

Just send us your prints, samples, or simply give us your requirements and let us design a straining element that is right for your application. In most cases, straining elements can be ordered by referencing Titan FCI's or any other manufacturers' strainer model number.



Titan Flow Control, Inc. *A Letter from our President*

Titan Flow Control, Inc. manufactures a complete line of very high quality pipeline strainers, double disc check valves, globe type silent check valves, and soft seated butterfly valves. Our product offerings include both a high quality import line as well as units crafted to meet full domestic requirements whenever needed.

Our management team has been designing and manufacturing industrial strainers for over 30 years. We have the ability to custom design units to conform to even the most complicated piping configurations imaginable. Our screen fabrication shop can quickly provide special screens in a wide selection of both perforated and wire mesh materials in sizes ranging from 20 through 500 mesh. We offer products fabricated from numerous alloys including bronze, ductile and cast iron, carbon steel, stainless steel, monel, alloy 20, nickel and hastelloy, as well as many others.

Every Titan unit is fabricated with premium components from certified vendors. The components that go into making a Titan FCI valve must conform to Titan's rigid standards. To test for meeting conformity, on arrival, every component is subjected to and must pass multiple, rigorous quality inspection procedures. Every casting carries a foundry heat number for immediate identification and for subsequent traceability. All parts are precision machined on the newest and most modern numerical control machinery - all manufactured in strict adherence to internationally recognized standards and specifications, including ANSI/ASME/API/NACE and ISO. All products manufactured by Titan FCI are 100% hydrostatically tested in accordance with applicable ANSI, API, MSS standards and customer specifications.

Titan FCI is proud to have earned one of the highest quality/price ratios of any reputable strainer/valve company in the world.

You will find the most impressive fact about a Titan FCI product is the product itself. Titan will be more than pleased to provide you with a sample of any product you request.

*Martin Gibbons
President*

Your Titan Flow Control Sales Representative:

If you need help contacting a Titan Sales Representative, call Titan FCI at (910)735-0000.

Titan FCI's new manufacturing facility - right off of Interstate 95, Exit 17.



TITAN

TITAN FLOW CONTROL, INC.

REPLACEMENT SCREENS AND BASKETS

TITAN FLOW CONTROL, INC



Cylindrical Screen, Style 'A'

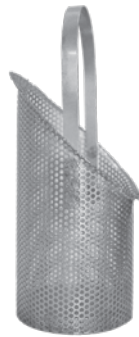

Slanted Type Basket, Style 'B'



Basket Type, Style 'C'

REPLACEMENTS FOR ANY MAJOR COMPETITOR'S MODEL STRAINER

Titan FCI can manufacture replacements, for not only Titan strainers, but for other companies' strainers as well!

In many cases, all Titan needs is the model number, size, and perforation. We can also provide a blank specification sheet, **Titan Straining Element Design Specification**, to help identify the exact design and dimensional data required. These sheets are conveniently available online at www.titanfci.com or by calling (910) 735-0000. Titan makes it easy to order the straining element you need!

MADE IN LUMBERTON, NC



Titan Flow Control, Inc. proudly manufactures its baskets and screens at its own facility in Lumberton, NC.

From cutting the perforation to welding on a handle, Titan's highly experienced staff creates each screen and basket with care and precision. Once completed, all screens and baskets are then inspected based on their design requirements before being shipped to the customer.

Because Titan manufactures replacement baskets and screens in-house, Titan is able to provide them to its customers **at a low cost AND at the highest quality**. Additionally, Titan's in-house manufacturing ensures that a variety of options are available upon demand, including **a wide selection of specialty perforations and meshes, dutchweave meshes, magnetic screen assemblies, drilled or wedgewire screens, pleated straining elements, and much more.**

High Quality, American-Made Screens and Baskets

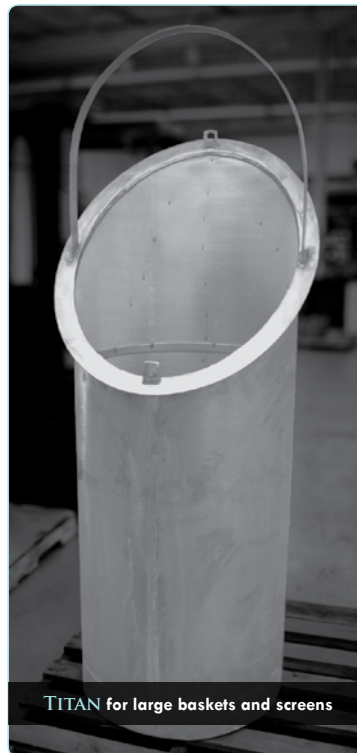

TITAN for large baskets and screens



TITAN for wedgewire & special materials

Titan FCI manufactures special screens and baskets for extreme pipeline conditions. Pictured above are screens made of wedgewire straining material which provides great strength and durability while maintaining a large open-area ratio.



TITAN for large quantities

Titan FCI's factory is capable of fulfilling all sizes of screen and basket orders. No order is too large - in size or in quantity! Titan prides itself in its ability to provide for each customer's individual needs.

For more information on screen and basket selection, see **Titan's Screen and Basket Selection Guide** available at www.titanfci.com or in the Technical Data Section of the catalog.

TITAN FLOW CONTROL, INC

Tel: 910-735-0000 ♦ Fax: 910-738-3848 ♦ titan@titanfci.com ♦ www.titanfci.com
290 Corporate Drive ♦ PO Box 7408 ♦ Lumberton, NC 28358



YOUR PIPELINE TO THE FUTURE!

**TITAN**

TITAN FLOW CONTROL, INC.



REPLACEMENT SCREENS AND BASKETS

TITAN FLOW CONTROL, INC.

quickest
YOUR PIPELINE TO THE FUTURE!

Titan can provide the screen and basket replacements you need, when you need them. Short lead times result in less downtime for you!



EXTENSIVE INVENTORY OF PRE-MADE SCREENS AND BASKETS

Titan FCI keeps thousands of manufactured screens and baskets in stock! By maintaining an inventory of the most common screen and basket sizes in standard perforations, Titan is able to meet the high demand for replacements as they are needed. Not only does this allow Titan to ship the standard screens and baskets right away, it also allows Titan's screen department to concentrate on unique or large orders and to prepare them quickly as well.

WIDE VARIETY OF PERFORATIONS AND MESHES IN STOCK

Titan stocks many standard and non-standard perforations and meshes so that the raw sheet materials are available when a basket or strainer is ordered. Consult a Titan sales representative to determine the opening size and material necessary for each application. More information is included in Titan's Screen and Basket Selection Guide in the Technical Section of the catalog and online at www.titanfci.com.

NEXT DAY REPLACEMENT BASKETS AND SCREENS AVAILABLE

Titan can ship out many orders next day (or possibly same day!). Because many replacement screens and baskets are pre-made, Titan can offer next day services for most of Titan's wye, basket, and duplex strainer models with standard screens and baskets. **Titan is often capable of shipping screens and baskets in 4 to 6 HOURS** while most competitors quote replacement lead times of 4 to 6 weeks! Call a Titan sales representative to check availability and delivery for your next replacement screen or basket requirement!

KNOWLEDGEABLE SALES AND ENGINEERING STAFF

Customer service is a priority at Titan Flow Control.

Titan FCI employs a sales and engineering staff with many years of experience in the industry. If you have any questions about screens or baskets, Titan will help you find the answer. Titan can help engineer screens and baskets for unique applications and designs. Your phone call will never be answered by an automated recording, but always by a real live person at Titan's offices located in Lumberton, NC.

Your Titan Flow Control Sales Representative:

If you need help contacting your local representative, call Titan Flow Control at (910) 735-0000.

TITAN FLOW CONTROL, INCTel: 910-735-0000 ♦ Fax: 910-738-3848 ♦ titan@titanfci.com ♦ www.titanfci.com
290 Corporate Drive ♦ PO Box 7408 ♦ Lumberton, NC 28358

TITAN**TITAN FLOW CONTROL, INC. ♦ CROSS REFERENCE CHART**

TITAN FLOW CONTROL, INC.

Y-Strainers ♦ Basket Strainers ♦ Duplex Strainers ♦ Fabricated Products

Y-STRAINERS				
CAST IRON	End Connection	Pressure Class	Mueller Number	Titan FCI Number
	Threaded	ANSI 250	11M	YS 12-CI
	Flanged	ANSI 125	758	YS 58-CI
	Flanged	ANSI 250	752	YS 59-CI

BRONZE	End Connection	Pressure Class	Mueller Number	Titan FCI Number
	Threaded	ANSI 125	351M	YS 55-BZ
	Threaded	ANSI 250	352M	YS 52-AB
	Solder End	ANSI 125	358SN	YS 56-BZ
Flanged	ANSI 150	851M	YS 54-AB	

CARBON STEEL	End Connection	Pressure Class	Mueller Number	Titan FCI Number
	Threaded	ANSI 600	861/581	YS 81-CS
	Socket Weld	ANSI 600	862/582	YS 82-CS
	Threaded	ANSI 1500	863M	YS 83-CS
	Socket Weld	ANSI 1500	864M	YS 84-CS
	Threaded	ANSI 2500	865	YS 85-CS
	Socket Weld	ANSI 2500	866	YS 86-CS
	Flanged	ANSI 150	761/781	YS 61-CS
	Flanged	ANSI 300	762/782	YS 62-CS
	Flanged	ANSI 600	764	YS 64-CS
	Flanged	ANSI 1500	766M	YS 68-CS
	Flanged	ANSI 2500	767	YS 70-CS
	Butt Weld	ANSI 300	762/782WE	YS 63-CS
	Butt Weld	ANSI 600	764WE	YS 65-CS
	Butt Weld	ANSI 1500	766MWE	YS 69-CS
	Butt Weld	ANSI 2500	767WE	YS 71-CS

STAINLESS STEEL	End Connection	Pressure Class	Mueller Number	Titan FCI Number
	Threaded	ANSI 600	861SS/581SS	YS 81-SS
	Socket Weld	ANSI 600	862SS/582SS	YS 82-SS
	Threaded	ANSI 1500	863MSS	YS 83-SS
	Socket Weld	ANSI 1500	864MSS	YS 84-SS
	Threaded	ANSI 2500	865SS	YS 85-SS
	Socket Weld	ANSI 2500	866SS	YS 86-SS
	Flanged	ANSI 150	761SS/781SS	YS 61-SS
	Flanged	ANSI 300	762SS/782SS	YS 62-SS
	Flanged	ANSI 600	764SS	YS 64-SS
	Flanged	ANSI 1500	766MSS	YS 68-SS
	Flanged	ANSI 2500	767SS	YS 70-SS
	Butt Weld	ANSI 300	762SS/782SSWE	YS 63-SS
	Butt Weld	ANSI 600	764SSWE	YS 65-SS
Butt Weld	ANSI 1500	766MSSWE	YS 69-SS	
Butt Weld	ANSI 2500	767SSWE	YS 71-SS	

Note: This page is for reference only. For exact dimensional comparisons, please consult factory. Titan's knowledgeable staff will be happy to advise you in any purchasing decisions.

BASKET TYPE STRAINERS				
CAST IRON	End Connection	Pressure Class	Mueller Number	Titan FCI Number
	Threaded	ANSI 125	125	BS 25-CI
	Flanged	ANSI 125	125F-CI	BS 25F-CI
	Flanged	ANSI 125	165	BS 65-CI
Flanged	ANSI 125	155M	BS 55-CI	

CARBON	End Connection	Pressure Class	Mueller Number	Titan FCI Number
	Threaded	ANSI 150	125-CS	BS 35-CS
	Flanged	ANSI 150	125F-CS	BS 35F-CS
	Flanged	ANSI 150	185	BS 85-CS
Flanged	ANSI 300	186	BS 86-CS	

STAINLESS	End Connection	Pressure Class	Mueller Number	Titan FCI Number
	Threaded	ANSI 150	125-SS	BS 35-SS
	Flanged	ANSI 150	125F-SS	BS 35F-SS
	Flanged	ANSI 150	185-SS	BS 85-SS
Flanged	ANSI 300	186-SS	BS 86-SS	

FABRICATED BASKET STRAINERS				
ALL MATL	End Connection	Pressure Class	Mueller Number	Titan FCI Number
	Flanged	ANSI 150	185FAB-B	FB21
	Flanged	ANSI 300	186FAB-B	FB31
	Flanged	ANSI 150	185FAB-Q	FB24
	Flanged	ANSI 300	186FAB-Q	FB34

FABRICATED TEE STRAINERS				
ALL	End Connection	Pressure Class	Mueller Number	Titan FCI Number
	Flanged	ANSI 150	41T	FT21
	Flanged	ANSI 300	42T	FT31

TEMPORARY START-UP STRAINERS				
ALL MATL	End Connection	Strainer Type	Mueller Number	Titan FCI Number
	N/A	BASKET	22	PS16
	N/A	CONE	23	PS15
	N/A	PLATE	24	PS17

DUPLEX STRAINERS				
ALL MATERIALS	Pressure Class	Hayward Number	Mueller Number	Titan FCI Number
	ANSI 125	50/53BTX	791SA	DS595-CI
	ANSI 125	50/53BTX	791FA	DS695-CI
	ANSI 150	50/53BTX	792SD	DS596-CS
	ANSI 150	50/53BTX	792FD	DS696-CS
	ANSI 150	50/53BTX	792SH	DS596-SS
ANSI 150	50/53BTX	792FH	DS696-SS	

TITAN FLOW CONTROL, INC.

YOUR PIPELINE TO THE FUTURE!

Tel: 910-735-0000 ♦ Fax: 910-738-3848 ♦ titan@titanfci.com ♦ www.titanfci.com
290 Corporate Drive ♦ PO Box 7408 ♦ Lumberton, NC 28358



TITAN FLOW CONTROL, INC. ♦ CROSS REFERENCE CHART

Double Disc Check Valves ♦ Center Guided Check Valves
Butterfly Valves ♦ Tri-flow Control Check Valves ♦ Suction Diffusers

DOUBLE DISC CHECK VALVES

DUCTILE IRON	Type	Pressure Class	Mueller Number	Titan FCI Number
	Wafer	ANSI 150	72-IHB-3-H	CV41-DI-B-S-1-S
	Wafer	ANSI 150	72-IHB-6-H	CV41-DI-B-S-2-S
	Wafer	ANSI 150	72-IHH-3-H	CV41-DI-S-S-1-S
	Wafer	ANSI 150	72-IHH-6-H	CV41-DI-S-S-2-S

♦ Titan FCI provides ductile iron at cast iron prices.

CARBON STEEL	Type	Pressure Class	Mueller Number	Titan FCI Number
	Wafer	ANSI 150	72-DHH-3-X	CV42-CS-S-S-1-X
	Wafer	ANSI 150	72-DHH-6-X	CV42-CS-S-S-2-X
	Wafer	ANSI 150	72-DHH-4-X	CV42-CS-S-S-3-X
	Wafer	ANSI 150	72-DHH-T-X	CV42-CS-S-S-6-X
	Wafer	ANSI 300	74-DHH-3-X	CV44-CS-S-S-1-X
	Wafer	ANSI 300	74-DHH-6-X	CV44-CS-S-S-2-X
	Wafer	ANSI 300	74-DHH-4-X	CV44-CS-S-S-3-X
	Wafer	ANSI 300	74-DHH-T-X	CV44-CS-S-S-6-X
	Wafer	ANSI 600	76-DHH-3-X	CV46-CS-S-S-1-X
	Wafer	ANSI 600	76-DHH-T-X	CV46-CS-S-S-6-X
	Wafer	ANSI 900	77-DHH-3-X	CV47-CS-S-S-1-X
	Wafer	ANSI 900	77-DHH-T-X	CV47-CS-S-S-6-X

STAINLESS STEEL	Type	Pressure Class	Mueller Number	Titan FCI Number
	Wafer	ANSI 150	72-HHH-3-X	CV42-SS-S-S-1-X
	Wafer	ANSI 150	72-HHH-4-X	CV42-SS-S-S-3-X
	Wafer	ANSI 150	72-HHH-H-X	CV42-SS-S-S-6-X
	Wafer	ANSI 300	74-HHH-3-X	CV44-SS-S-S-1-X
	Wafer	ANSI 300	74-HHH-4-X	CV44-SS-S-S-3-X
	Wafer	ANSI 300	74-HHH-H-X	CV44-SS-S-S-6-X
	Wafer	ANSI 600	76-HHH-4-X	CV46-SS-S-S-3-X
	Wafer	ANSI 600	76-HHH-H-X	CV46-SS-S-S-6-X
	Wafer	ANSI 900	77-HHH-4-X	CV47-SS-S-S-3-X
	Wafer	ANSI 900	77-HHH-H-X	CV47-SS-S-S-6-X

BUTTERFLY VALVES

IRON	Type	Pressure Class	Mueller Number	Titan FCI Number
	Wafer	ANSI 125	65M	BF 75-CI
Lug	ANSI 150	88	BF 76-DI	

TITAN'S PRODUCTS ARE EASY TO IDENTIFY

Y-STRAINERS	YS	FABRICATED TEE STRAINERS	FT
BASKET STRAINERS	BS	FABRICATED BASKET STRAINERS	FB
DUPLEX STRAINERS	DS	BALL VALVE BLOW-OFF VALVES	BV
CHECK VALVES	CV	TEMPORARY STRAINERS	PS
SUCTION DIFFUSERS	SD	TRI-FLOW CHECK VALVES	TF

CENTER GUIDED SILENT CHECK VALVES

DUCTILE IRON	Type	Pressure Class	Mueller Number	Titan FCI Number
	Globe	ANSI 125	105MAP	CV 50-DI-B
	Globe	ANSI 125	105MAT	CV 50-DI-S
	Globe	ANSI 250	107MAP	CV 52-DI-B
	Globe	ANSI 250	107MAT	CV 52-DI-S
	Wafer	ANSI 125	91AP	CV 90-DI-B
	Wafer	ANSI 125	91AT	CV 90-DI-S

♦ Model CV 52 is dual rated for ANSI 250/300.
♦ Model CV 90 is dual rated for ANSI 125/250.

CARBON	Type	Pressure Class	Mueller Number	Titan FCI Number
	Globe	ANSI 150	105MDT	CV 51-CS-S
Globe	ANSI 300	109MDT	CV 52-CS-S	

STAINLESS STEEL	Type	Pressure Class	Mueller Number	Titan FCI Number
	Globe	ANSI 150	105MHT	CV 51-SS-S
	Globe	ANSI 300	109MHT	CV 52-SS-S
	Wafer	ANSI 150	92MHT	CV 91-SS-S
	Wafer	ANSI 300	94MHT	CV 91-SS-S
	Threaded	ANSI 300	303-HT	CV 80-SS

♦ Model CV 91 is dual rated for ANSI 150/300.

TRI-FLOW CONTROL CHECK VALVES

IRON	End Connection	Pressure Class	Mueller Number	Titan FCI Number
	Flanged	ANSI 125	721	TF 21-CI

SUCTION DIFFUSERS

IRON	End Connection	Pressure Class	Mueller Number	Titan FCI Number
	Flanged	ANSI 125	1011	SD 22-CI

Note: This page is for reference only. For exact dimensional comparisons, please consult factory. Titan's knowledgeable staff will be happy to advise you in any purchasing decisions.

SPECIFY WITH CONFIDENCE AND MAXIMIZE YOUR PURCHASING DOLLARS!

TITAN FLOW CONTROL, INC.
YOUR PIPELINE TO THE FUTURE!

Tel: 910-735-0000 ♦ Fax: 910-738-3848 ♦ titan@titanfci.com ♦ www.titanfci.com
290 Corporate Drive ♦ PO Box 7408 ♦ Lumberton, NC 28358



TITAN

Pipeline Strainers

Clean and Protect your pipelines with
TITAN QUALITY STRAINERS

Strainers are an efficient way to remove debris from industrial and commercial pipelines. By mechanically removing potentially harmful debris before it reaches expensive pumps, compressors, valves, etc., strainers are essential in preventing damage to downstream equipment.

Titan Flow Control, Inc. offers a huge variety of strainer designs and options:

TYPES: Y-Strainer, Basket Strainer, Duplex Strainer, Temporary Strainer, Fabricated Strainer

SIZES: 1/4" through 72"

ANSI CLASSES: 125, 150, 300, 600, 900, 1500, 2500

MATERIALS: Stainless Steel, Carbon Steel, Cast Iron, Bronze, Brass, and other special alloys

END CONNECTIONS: Threaded, Flanged, Butt Weld, Socket Weld, Solder



TITAN FLOW CONTROL, INC.



Types of Pipeline Strainers

Y-Strainers, Basket Strainers, Duplex Strainers, and Fabricated Strainers

WYE ("Y") STRAINERS can be used in horizontal or vertical (downward) pipelines. A cylindrical perforated or mesh-lined screen within the strainer collects debris as the flow travels through the strainer. Cleaning Y-strainers normally requires the removal of the screen from the strainer, but a blow-off drain valve can be used to increase the time between cleanings.

Features of Titan's Y-strainers include large straining capacities, precision machined seats, a standard blow-off drain connection furnished with a plug on low pressure models, and many screen options. All cast iron and carbon steel units are epoxy painted to resist rust; all threaded and socket weld end connections have hex ends for easy installation. Many models have gauge taps as a standard feature. Titan's Y-strainers are available in ANSI classes up to 2500.

Ask Titan about exotic body materials available such as WC6, Alloy 20, and 316L!

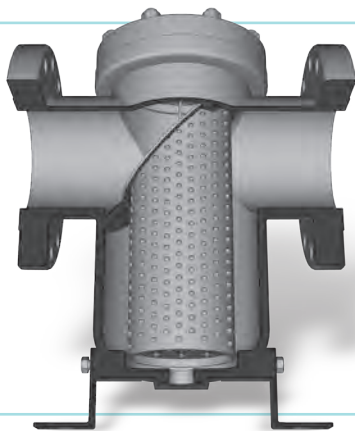
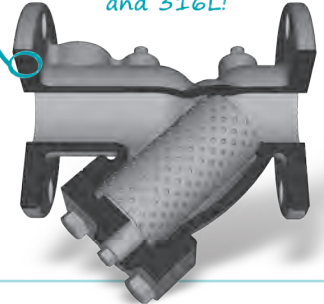

BASKET STRAINERS are used commonly in horizontal applications where cleaning will be less frequent. Because of their larger bodies, they typically provide more open area for debris collection than Y-strainers. The straining element (a.k.a the "basket") for a basket strainer has a handle for easy removal and secure placement within the strainer's body. The basket can have a slanted top design (as shown to the left) or a straight top design.

Titan's Basket Strainers feature large straining capacities, precision machined seats, standard blow-off drain connections and cover vents furnished with plugs, and many screen options. All cast iron and carbon steel units are epoxy painted to resist rust; all threaded end connections have hex ends for easy installation. Many models have gauge taps as a standard feature. Titan also offers a variety of cover designs, including a quick-open cover for easy access to the straining element.

DUPLEX STRAINERS are ideal for non-interruptible applications. Two basket chambers and a flow diverter system allow the pipeline flow to be switched from one chamber to the other. Because the flow is completely isolated to a single chamber, the inactive chamber can be cleaned without shutdown.

Titan's Duplex Strainers are high quality, compact units. They are easy to operate and maintain with no special tools required to remove the straining element from the chamber. All cast iron and carbon steel units are epoxy painted to resist rust. Titan's Duplex Strainers are available with threaded and flanged ends in a variety of materials.

2 basket chambers means no downtime for cleaning!



See the fabricated section of Titan's catalog for additional design options



FABRICATED STRAINERS provide additional flexibility and design options for unique applications. Titan offers fabricated basket strainers, tee strainers, duplex strainers, and temporary strainers (as pictured on the left). Titan even manufactures fabricated strainers with special cleaning options, hand-operated and motorized, to facilitate debris removal. A variety of options are available for flow variations and cover designs, including Davit cover assemblies.

Titan has a highly experienced engineering team and fabrication department that is customer-focused and detail-oriented, ensuring that a Titan fabricated product will not only meet the needs of the application, but also will be of the highest quality.

TITAN

SCREEN AND BASKET SELECTION GUIDE

Choosing the right straining element

Introduction:

One of the most important design considerations when purchasing a strainer is specifying the perforation or mesh size of the straining element. The straining element (commonly referred to as a screen for WYE strainers and a basket for basket strainers) is a mechanical filter which removes and retains particles too large to pass through yet allows the flowing media (liquid or gas) to pass unobstructed. This process is illustrated in Figure 1. By cleaning the flowing media, the straining element helps to protect expensive downstream equipment such as pumps, meters, spray nozzles, compressors, and turbines.

A Titan FCI strainer should always be installed ahead of pumps and other expensive, downstream equipment to help ensure proper protection and trouble-free operation. This even holds true for "clean lines" to protect against scale and accidentally introduced items such as: tools, gaskets, nuts, or bolts.

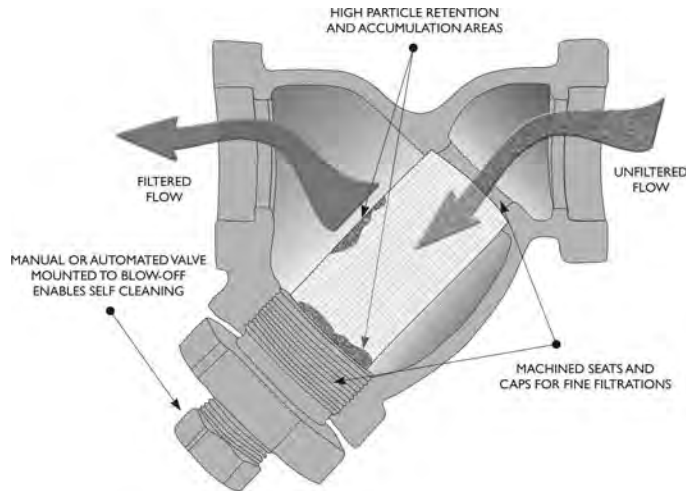

Figure 1: Straining Illustration

Determining Opening Size:

In general, screen openings should be approximately one-half the diameter of the largest allowable particle. The largest allowable particle is defined as the size of particle that can pass through downstream equipment without causing damage. For example, if the maximum allowable particle is 1/16 inch then the screen opening would be specified at 1/32 inch. In addition to the size of particles, the quantity of debris in the flowing media must also be considered when determining the appropriate opening size.

Straining elements can only be used to remove insoluble floating impurities. The most common range of particle retention is 1 inch down to 40 microns (.0015 inch). See Figure 2 for a comparison of sizes for a variety of common particles.

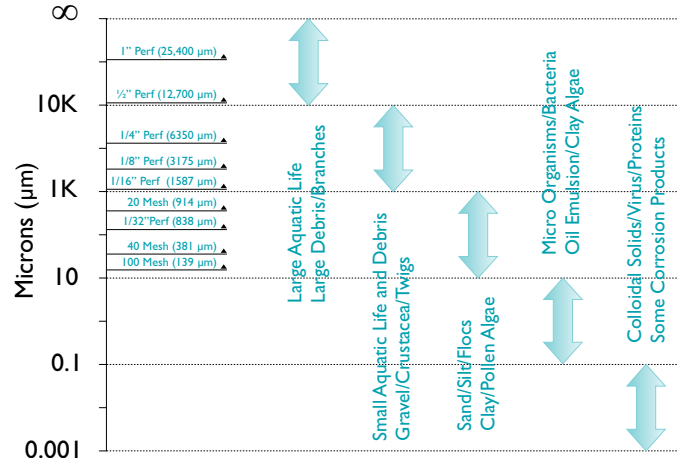

Figure 2: Particle Size Comparison Chart

Determining Opening Size: continued...

A common mistake is to specify a screen opening that is too small for the application. This can lead to overstraining and should be avoided for the following reasons:

- Maintenance costs are significantly increased due to excessive cleaning requirements.
- Pressure drop is increased dramatically.
- The straining element may become damaged and fail.

Straining elements are not designed to withstand the same pressure as the strainer housing. If the straining element becomes fully clogged, it will be exposed to the same pressure as the housing. In most cases, this will cause the straining element to fail. For these types of applications, Titan FCI offers special drilled or wedge wire screens that can withstand full line pressure when clogged. A convenient way to monitor the differential pressure is to install pressure gauges on both the inlet and outlet sides of the strainer. It is not recommended to allow the differential pressure to exceed 20 psi.

In some applications requiring finer filtrations, it may be advisable to strain in gradual steps. This is accomplished by placing progressively smaller straining elements in series. As always, a Titan FCI engineer is available to assist you in developing a solution for any special straining requirements you may have.

Construction Material:

Regardless of the strainer housing material being used, the most common construction material used for straining elements is stainless steel. This is due to the inherent resistance to corrosion stainless steel provides. As such, Titan FCI's standard construction material for all straining elements is Type 304 stainless steel. Other materials (316 SS, 316L, and Monel) are available upon application. Please consult a Titan FCI engineer for determining the best material for your application.

Screen Types:

In general, strainer elements are available in three types: *perforated*, *wire mesh*, and *reinforced wire mesh lined*.

Perforated:

Titan FCI offers a wide range of perforation sizes. To make the selection process easier, Titan FCI recommends a standard perforation size suitable for general service for each type of strainer. The standard perforation size has been determined to provide the best balance of open area ratio (OAR), hole arrangement, and gauge thickness that results in the least amount of pressure drop. Please refer to each strainer's specification sheet for standard perforation size recommendations. Additionally, Table 1 presents a general guide for selecting straining element sizes for water, steam, oil, gasoline and air.

Where permissible, Titan FCI uses a 60° staggered round hole arrangement because of its superior strength and large open area ratio (OAR). On smaller perforation sizes, Titan FCI uses a straight line, round hole pattern that allows for a large OAR yet does not compromise gauge thickness. In general, as the hole diameter becomes smaller and the OAR increases, the gauge thickness inherently becomes thinner.

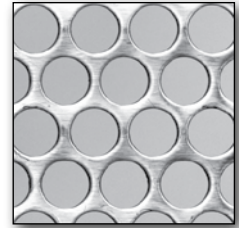

60° Staggered Round Hole Arrangement

Wire Size Diameters and Washburn & Moen Gauge Equivalents

Inch	Gauge
.120	11 Ga.
.105	12 Ga.
.092	13 Ga.
.080	14 Ga.
.072	15 Ga.
.063	16 Ga.
.054	17 Ga.
.047	18 Ga.
.041	19 Ga.
.035	20 Ga.
.032	21 Ga.

Wire Mesh:

For finer straining applications, down to 40 micron, wire mesh straining elements are available. Titan FCI utilizes a mono-filament, plain square weave that exhibits large OAR and very low flow resistance. Other types of weaves, such as plain Dutch and Twilled Dutch weave, are also available upon request. As with perforated straining elements, Titan FCI has developed standard mesh sizes suitable for general service for each type of strainer. Unsupported wire mesh straining elements are only suitable for strainers under 2 inches in size, constructed of 20 or 30 mesh, and operating within low pressure applications (under 200 psi). For larger strainers, finer mesh sizes, and higher pressure applications reinforced mesh lined screens must be used.

Wire Mesh Lined:

In most cases, wire mesh straining elements are reinforced with a heavier gauge, perforated metal backing to provide additional support. Titan FCI's standard perforated metal backing is 5/32 inch which provides excellent support without significantly diminishing the OAR.

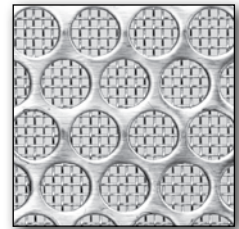

Wire Mesh with Perforated Backing

Table 1: Straining Element Selection Guidelines: ⁽¹⁾

Pipeline Media	Strainer Size	Coarse Straining	→	Fine Straining
Air or Gas	1/2" ~ 2"	1/32" perf.	60 mesh	100 mesh
	2 1/2" ~ 4"	1/16" perf.	3/64" perf.	60 mesh
	5" and up	1/8" perf.	1/10" perf.	40 mesh
Gasoline	1/2" ~ 2"	1/32" perf.	30 mesh	100 mesh
	2 1/2" ~ 6"	1/16" perf.	1/32" perf.	60 mesh
	8" and up	1/10" perf.	1/32" perf.	40 mesh
Oil - Low Viscosity	1/2" ~ 2"	1/16" perf.	1/32" perf.	30 mesh
	2 1/2" ~ 6"	3/16" perf.	1/8" perf.	1/16" perf.
	8" and up	3/8" perf.	1/4" perf.	1/8" perf.
Oil - Medium Viscosity	1/2" ~ 2"	1/10" perf.	1/16" perf.	20 mesh
	2 1/2" ~ 6"	1/4" perf.	3/16" perf.	1/8" perf.
	8" and up	3/8" perf.	1/4" perf.	3/16" perf.
Oil - High Viscosity	1/2" ~ 2"	1/8" perf.	1/10" perf.	1/16" perf.
	2 1/2" ~ 6"	3/8" perf.	1/4" perf.	3/16" perf.
	8" and up	1/2" perf.	3/8" perf.	1/4" perf.
Steam	1/2" ~ 2"	1/32" perf.	30 mesh	60 mesh
	2 1/2" ~ 4"	3/64" perf.	1/32" perf.	30 mesh
	5" and up	1/16" perf.	3/64" perf.	1/32" perf.
Water	1/2" ~ 2"	1/32" perf.	20 mesh	30 mesh
	2 1/2" ~ 4"	1/8" perf.	1/16" perf.	3/64" perf.
	5" and up	1/4" perf.	1/8" perf.	3/64" perf.

1. Represents a general guide for the selection of strainer element sizes. Should not be taken as an absolute guide as each particular application introduces its own set of unique requirements. When in doubt, please contact a Titan FCI engineer.

Table 2: Standard Mesh and Perforated Configurations ⁽¹⁾⁽²⁾

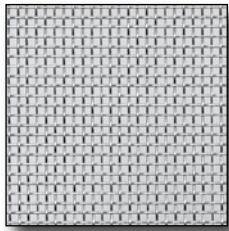

20 Mesh
51.8% Open Area
.036 Openings
(.914 mm / 914 μm)
.014 Wire Diameter

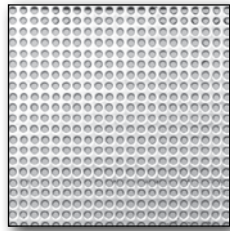

1/32" Diameter
(.033 in / 0.83 mm)
.055 Centers
28% Open Area
330 holes/sq. in.
Straight Line

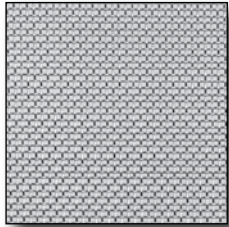

30 Mesh
44.8% Open Area
.0223 Openings
(.566 mm / 566 μm)
.011 Wire Diameter

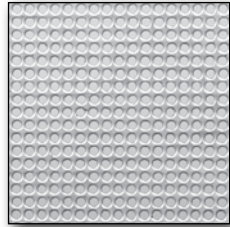

3/64" Diameter
(.045 in / 1.14 mm)
.066 Centers
36% Open Area
225 holes/sq. in.
Straight Line

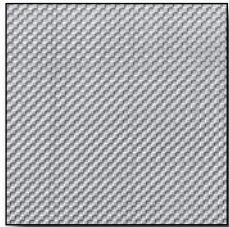

40 Mesh
36% Open Area
.015 Openings
(.381 mm / 381 μm)
.010 Wire Diameter

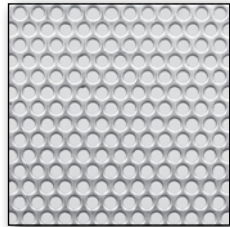

1/16" Diameter
(.0625 in / 1.58 mm)
3/32" Centers
41% Open Area
132 holes/sq. in.
Staggered Line

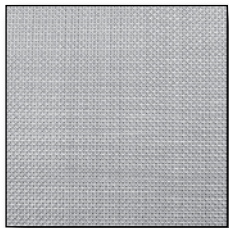

60 Mesh
33.9% Open Area
.0097 Openings
(.246 mm / 246 μm)
.007 Wire Diameter

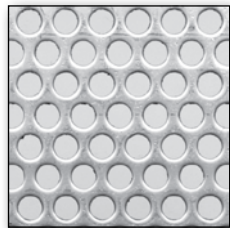

1/8" Diameter
(.125 in / 3.17 mm)
3/16" Centers
40% Open Area
33 holes/sq. in.
Staggered Line

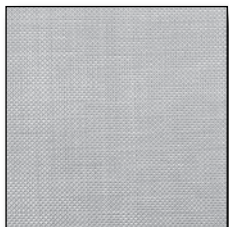

80 Mesh
36% Open Area
.0075 Openings
(.190 mm / 190 μm)
.005 Wire Diameter

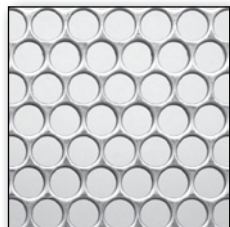

5/32" Diameter
(.1563 in / 3.96 mm)
3/16" Centers
63% Open Area
33 holes/sq. in.
Staggered Line

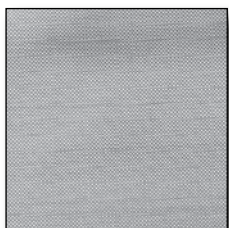

100 Mesh
30.3% Open Area
.0055 Openings
(.139 mm / 139 μm)
.0045 Wire Diameter

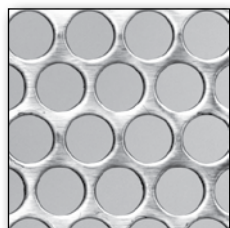

1/4" Diameter
(.25 in / 6.35 mm)
5/16" Centers
58% Open Area
12 holes/sq. in.
Staggered Line

Table 3: Optional Mesh Configurations ⁽³⁾

Mesh (Linear inch)	Wire Dia. (in)	Hole Openings		Open Area (%)
		(in)	(μm)	
20	.016	.034	863	46.2
20	.023	.027	685	29.2
30	.010	.0233	591	48.9
30	.014	.0193	490	33.5
40	.009	.016	406	41.0
40	.011	.014	355	31.4
50	.009	.011	279	30.3
60	.0065	.0102	259	37.5
60	.0080	.0087	221	27.2
80	.0055	.0070	177	31.4
80	.0060	.0065	165	27.0
100	.0040	.0060	152	36.0
100	.0045	.0055	139	30.3
120	.0037	.0046	116	30.7
130	.0034	.0043	109	31.1
140	.0029	.0042	106	34.9
150	.0026	.0041	104	37.4
160	.0025	.0038	96	36.4
170	.0024	.0035	88	35.1
180	.0023	.0033	83	34.7
200	.0021	.0029	73	33.6
325	.0011	.0020	50	42.0
400	.0010	.0015	38	36.0
500	.0010	.0010	25	25.0

Table 4: Optional Perf. Configurations ⁽³⁾

Hole Diameter (in)	Centers (in)	Open Area (%)
.027	.05 Straight	23.0
.045	.066 Straight	36.0
.045	.088 Staggered	24.0
1/16	7/64 Staggered	30.0
1/16	1/8 Staggered	22.5
5/64	7/64 Staggered	46
5/64	1/8 Staggered	36
3/32	5/32 Staggered	33.0
3/32	3/16 Staggered	25.0
3/32	1/4 Straight	12.7
.100	5/32 Staggered	36.0
.117	5/32 Staggered	51.0
1/8	7/32 Staggered	30.0
1/8	1/4 Staggered	23.0
9/64	3/16 Staggered	51.0
5/32	1/4 Staggered	34.0
3/16	1/4 Staggered	50.0
3/16	5/16 Staggered	33.0
3/16	1/2 Straight	10.0
7/32	5/16 Staggered	45.0
1/4	3/8 Staggered	40.0
1/4	1/2 Staggered	23.0
1/4	1/2 Straight	20.0
5/16	7/16 Staggered	46.0
3/8	1/2 Staggered	52.0
3/8	9/16 Staggered	40.0
7/16	5/8 Staggered	45.0
1/2	1 1/16 Staggered	48.0
1/2	3/4 Staggered	40.0

- Notes:
- Titan FCI's standard construction material for all screens and baskets is Type 304 Stainless Steel. Other materials (i.e. Type 316 and Monel) are available upon request. Please consult factory for pricing and availability for non-stock materials.
 - Table 2 represents Titan FCI's most commonly stocked mesh and perforation arrangements. A large variety of special mesh and perforation options are available. Please consult the factory or your local sales representative regarding the specific requirements of your application.
 - Table 3 & 4 represent optional mesh and perf configurations which are not routinely stocked but can be furnished upon request. Please consult factory for pricing and availability.
 - For mesh lined screens or baskets, 5/32" perf is most commonly used for outer support (backing). If other backing is required, please specify at time of order.

4 Titan Flow Control - Standard Screen and Basket Designs

Titan FCI can manufacture straining elements for all types of strainers including "Y", "T", and basket in a wide variety of materials. We can also manufacture conical/temporary strainers.

Please send us your prints, samples, or simply give us your requirements and let us design a straining element for you. In most cases, straining elements can be ordered by referencing Titan FCI's or any other manufacturers' strainer model number.

When ordering, please specify:

1. Pipe Size
2. Straining Element Type
3. Perforation or Mesh
4. Construction Material
5. Design Type (cone, basket etc.)
6. Flow Direction
7. Open Area % and Length
8. Pressure Ratio

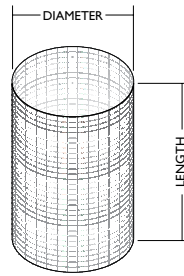

Figure 3:
STYLE 'A'
Cylindrical Screen
Generally used for "Y"
Type Strainers.

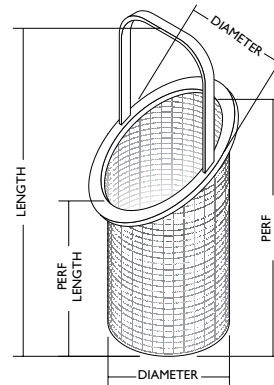

Figure 4:
STYLE 'B'
Slanted Type Basket
Typically used for larger sized Simplex and Duplex Basket Strainers. Slanted inlet side reduces pressure drop across the strainer. Strainer cover presses down on handle to ensure straining element remains securely seated.

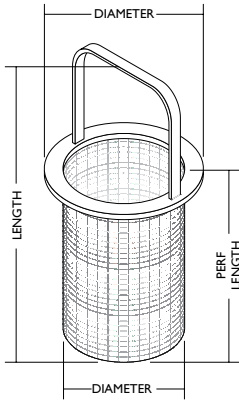

Figure 5:
STYLE 'C'
Basket Type
Typically used for smaller sized Simplex and Duplex Basket Strainers. Strainer cover presses down on handle to ensure straining element remains securely seated.

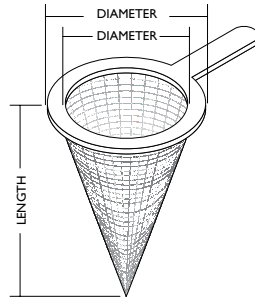

Figure 6:
STYLE 'D'
Temporary Conical
Often referred to as a cone or witch's hat strainer. Used during start-up operations.

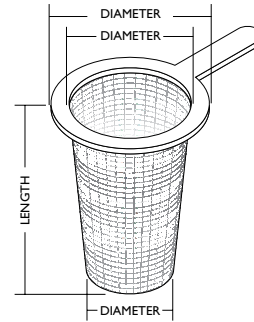

Figure 7:
STYLE 'E'
Temporary Basket
Often referred to as a basket or pilgrim's hat strainer. Used during start-up operations.

Screen Specification Sheets are available online at <http://www.titanfci.com/technical-data/screen-selection/screen-and-basket-specifications>

Titan Flow Control - Special Screen and Basket Designs

Magnetic Screen Assembly:

Magnetic screen assemblies are recommended for applications that require the removal and retention of microscopic ferrous particles. Virtually any Titan FCI strainer can be fitted with powerful ALNICO magnetic inserts to provide protection against both magnetic and non-magnetic particles. These magnetic inserts create a continuous magnetic field within the interior of the straining element trapping ferrous particles even the finest mesh would typical not remove. Magnetic screen assemblies can effectively be employed in lubrication systems, hydraulic systems, and machine coolant systems.

Special Drilled or Wedge Wire Screens:

Titan FCI can also fabricate straining elements that will withstand full line pressure when clogged. These straining elements have individually drilled holes in heavy gauge metal (up to 3/8" thick) or utilize wedge wire.

Pleated (Convolved) Straining Elements:

Particle retention is directly related to the amount of surface area available on the straining element. As straining occurs, the gradual retention of particles can cause a layered build-up on the surface of the straining element. With cylindrical straining elements, this accumulation pattern can quickly clog the outlet side of the strainer causing a significant increase in pressure drop. This is illustrated in Figure 8. To solve this problem, Titan FCI can fabricate pleated straining elements which expand the straining surface area and disperse the particles in a uniform manner. This alleviates the layered build-up and typical loss in pressure. This is illustrated in Figure 9.

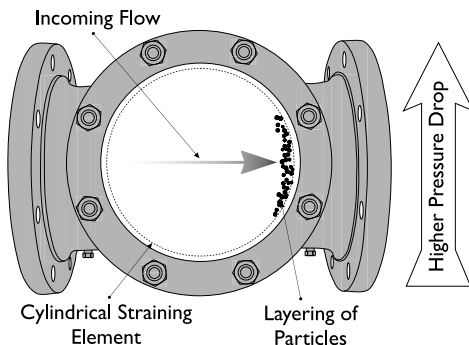

Figure 8: Top View - Basket Strainer - Cylindrical Straining Element

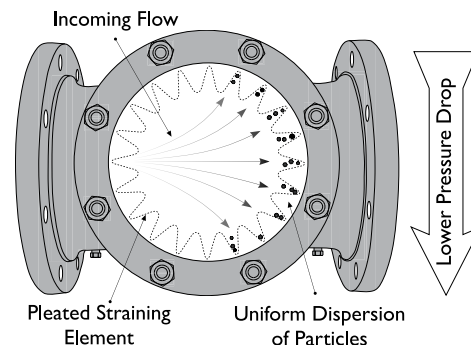

Figure 9: Top View - Basket Strainer - Pleated Straining Element



TITAN FLOW CONTROL, INC.

TECHNICAL AND PERFORMANCE DATA

PRESSURE DROP CHARTS ♦ WYE & BASKET STRAINERS

WYE Strainers - Small Models

Models: YS12 - YS52 - YS55 - YS56 - YS81 - YS82

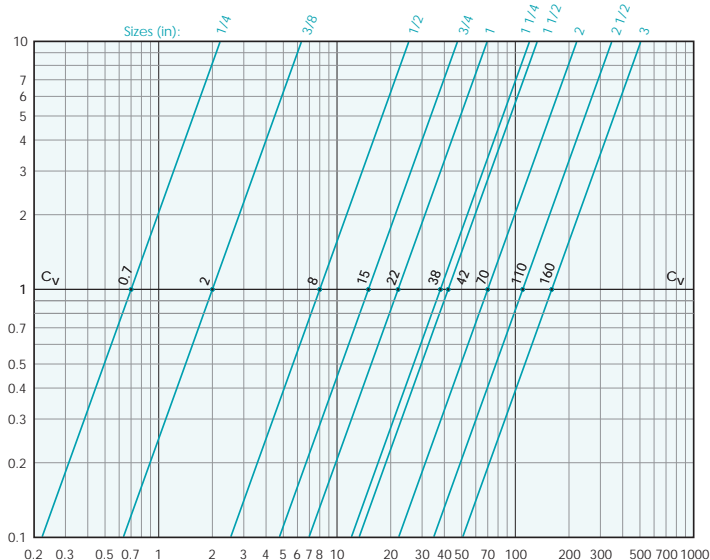

Legend: Pressure Drop - PSI (y - axis) versus Flow Rate - GPM (x -axis)

WYE Strainers - Large Models

Models: YS58 - YS59 - YS54 - YS61 - YS62 - YS63 - YS64 - YS65

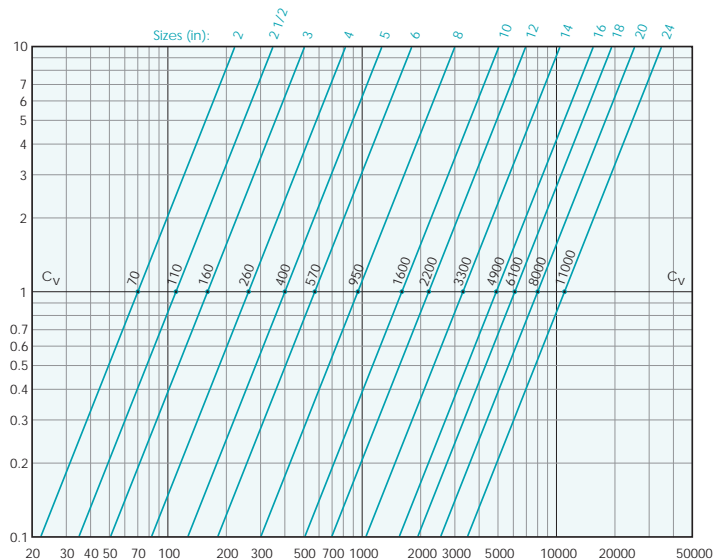

Legend: Pressure Drop - PSI (y - axis) versus Flow Rate - GPM (x -axis)

WYE Strainers - High Pressure - Class 900 & 1500

Models: YS66 - YS67 - YS68 - YS69 - YS83 - YS84

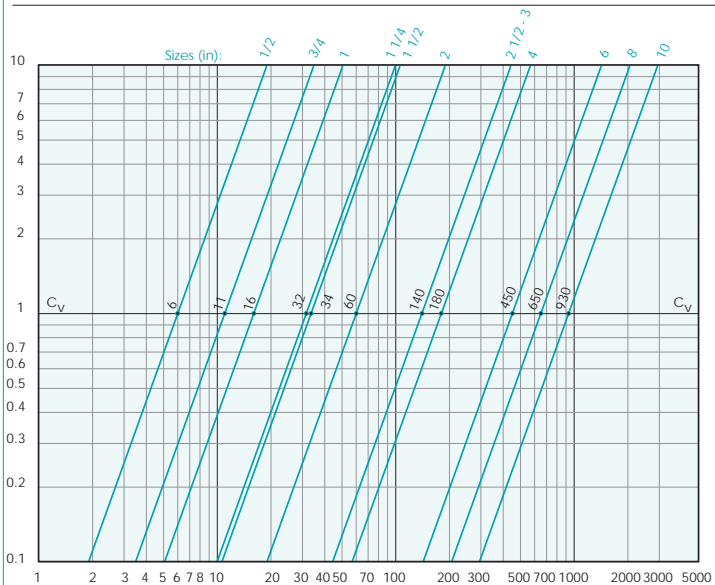

Legend: Pressure Drop - PSI (y - axis) versus Flow Rate - GPM (x -axis)

WYE Strainers - High Pressure - Class 2500

Models: YS70 - YS71 - YS85 - YS86

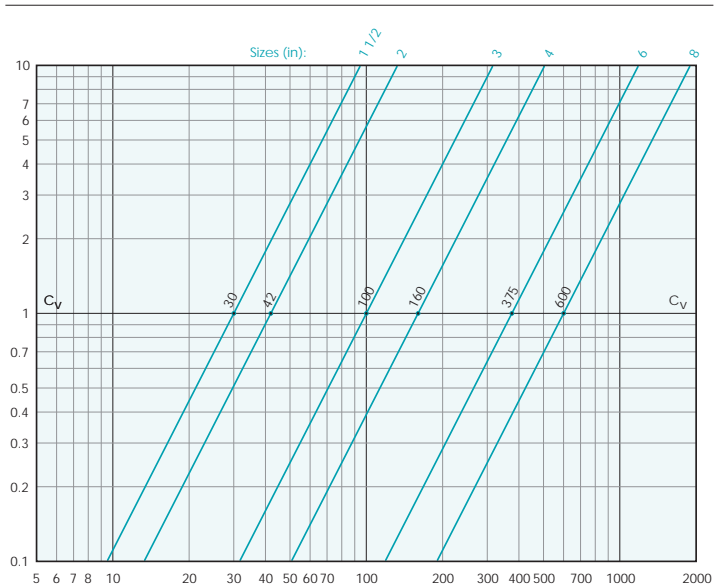

Legend: Pressure Drop - PSI (y - axis) versus Flow Rate - GPM (x -axis)

Pressure Drop Equation for Liquids:

$$\Delta P = G \times (Q / Cv)^2 \times Cr$$

ΔP = Pressure drop (psi)
 Cv = Flow coefficient factor

G = Specific gravity of liquid
 Cr = Correction factor for mesh and viscosity
 Q = Flow rate (GPM)

- These curves are theoretical; actual results may vary depending on installation conditions and other variables. Use these values for reference only.
- The above pressure drop charts are based upon 1/8" perforated screens and baskets handling clean water at 60 °F during ideal inlet and outlet conditions. Therefore, they should only be used for estimation purposes.
- For fluids other than water, multiply the pressure drop (ΔP) obtained from the charts by the specific gravity of the fluid in question.
- For mesh lined screens, multiply the pressure drop (ΔP) obtained from the charts by the corresponding correction factor shown in the Cv correction table.

TITAN FLOW CONTROL, INC.

Tel: 910-735-0000 ♦ Fax: 910-738-3848 ♦ titan@titanfci.com ♦ www.titanfci.com
 290 Corporate Drive ♦ PO Box 7408 ♦ Lumberton, NC 28358



TITAN FLOW CONTROL, INC.

TECHNICAL AND PERFORMANCE DATA

PRESSURE DROP CHARTS ♦ WYE & BASKET STRAINERS

Basket Strainers - Threaded Ends & Flanged Ends

Models: BS25 - BS25F - BS35 - BS35F

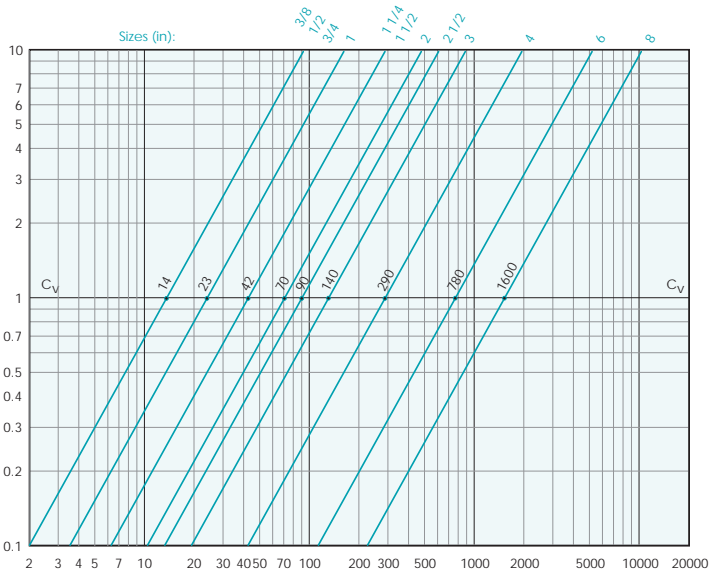

Legend: Pressure Drop - PSI (y - axis) versus Flow Rate - GPM (x - axis)

Basket Strainers - Flanged Ends

Models: BS55 - BS65 - BS85 - BS86 - BS95

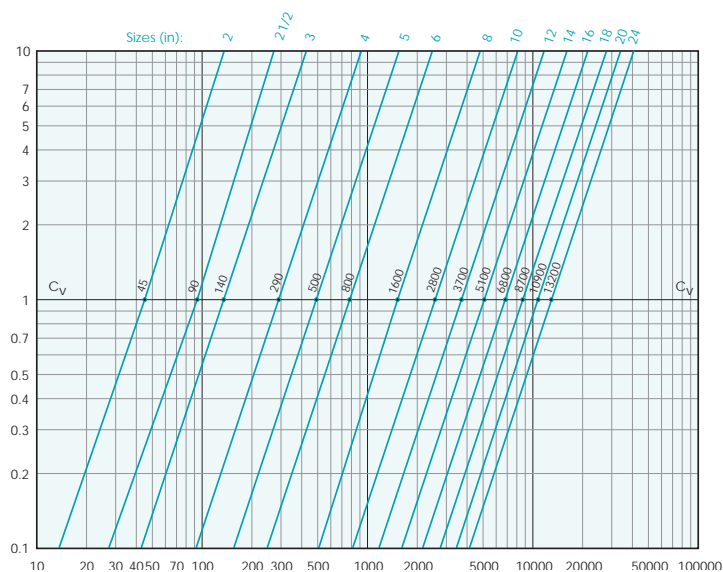

Legend: Pressure Drop - PSI (y - axis) versus Flow Rate - GPM (x - axis)

Cv CORRECTION FACTOR TABLE

Centistokes	(SSU)	Perf. (Unlined)	20 MESH	40 MESH	60 MESH	80 MESH	100 MESH	120 MESH	150 MESH	200 MESH	300 MESH	25 Micron	10 Micron	5 Micron
2	30 (Water)	1.00	1.05	1.2	1.4	1.6	1.7	1.8	2.0	2.2	2.35	3.0	3.5	4.0
10	60	1.1	1.15	1.4	1.5	1.7	1.8	2.2	2.3	2.4	2.55	---	---	---
20	100	1.2	1.25	1.5	1.6	1.9	2.1	2.35	2.45	2.6	2.75	---	---	---
32	150	1.3	1.35	1.6	1.7	2	2.2	2.45	2.85	3	3.15	---	4.0	---
43	200	1.4	1.45	1.7	1.8	2.1	2.3	2.55	3.0	3.2	3.35	4.0	---	---
54	250	1.45	1.5	1.75	1.85	2.2	2.35	2.65	3.1	3.3	3.4	---	---	---
76	350	1.5	1.6	1.8	1.9	2.3	2.45	2.75	3.2	3.4	3.5	---	---	---
100	500	1.6	1.7	1.9	2.1	2.4	2.6	2.8	3.35	3.6	3.75	---	---	---
162	750	1.65	1.9	2.1	2.3	2.5	2.7	2.9	3.5	3.7	3.9	---	---	---
216	1000	1.7	2.0	2.2	2.4	2.6	2.8	3.0	3.6	3.8	4.0	---	---	---
325	1500	1.8	2.1	2.3	2.6	2.75	3	3.2	3.8	4.1	4.3	---	---	---
433	2000	1.9	2.2	2.4	2.7	2.9	3.2	3.4	4.05	4.6	5.5	---	---	---
650	3000	2.0	2.3	2.6	2.9	3.5	3.5	3.8	4.6	5.0	5.2	---	---	---
866	4000	2.1	2.45	2.8	3.15	3.6	3.9	4.2	4.9	---	---	---	---	---
1083	5000	2.2	2.6	3	3.4	3.8	4.2	4.6	---	---	---	---	---	---
1624	7500	2.35	2.8	3.4	3.8	4.3	4.75	---	---	---	---	---	---	---
2200	10000	2.5	3.0	3.5	4.0	4.5	5.0	---	---	---	---	---	---	---
3000	13500	3.0	3.5	---	---	---	---	---	---	---	---	---	---	---
5000	22500	4.0	4.5	5.0	5.5	6.0	6.5	7.5	8.0	8.5	9.0	9.5	10.0	10.5
6000	27300	4.2	---	---	---	---	---	---	---	---	---	---	---	---
15000	67000	6.0	6.5	7.0	7.5	8.0	8.5	9.0	9.5	10.0	10.5	11.0	11.5	12.0
18900	86000	8.0	8.5	---	---	---	---	---	---	---	---	---	---	---
20000	89300	8.5	9.0	---	---	---	---	---	---	---	---	---	---	---

Multiply the Correction Factor by the pressure drop obtained from the charts in order to calculate Δ P for other liquids (besides water) and mesh lined screens and baskets.

Pressure Drop Equation for Liquids:

$$\Delta P = G \times (Q / Cv)^2 \times Cr$$

Δ P = Pressure drop (psi)
Cv = Flow coefficient factor

G = Specific gravity of liquid
Q = Flow rate (GPM)
Cr = Correction factor for mesh and viscosity

- These curves are theoretical; actual results may vary depending on installation conditions and other variables. Use these values for reference only.
- The above pressure drop charts are based upon 1/8" perforated screens and baskets handling clean water at 60 °F during ideal inlet and outlet conditions. Therefore, they should only be used for estimation purposes.
- For fluids other than water, multiply the pressure drop (Δ P) obtained from the charts by the specific gravity of the fluid in question.
- For mesh lined screens, multiply the pressure drop (Δ P) obtained from the charts by the corresponding correction factor shown in the Cv correction table.

TITAN FLOW CONTROL, INC.

Tel: 910-735-0000 ♦ Fax: 910-738-3848 ♦ titan@titanfci.com ♦ www.titanfci.com
290 Corporate Drive ♦ PO Box 7408 ♦ Lumberton, NC 28358



TEMPLATES FOR DRILLING & PRESSURE/TEMPERATURE RATINGS

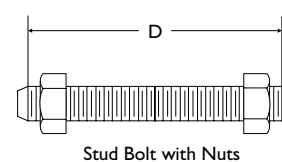
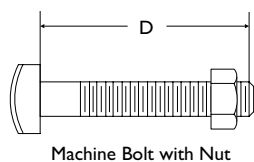
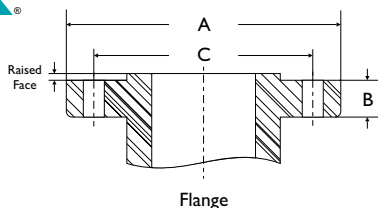

CLASS 125 & 150 FLANGES (3)	Pipe Size	Dia. of Flange (A)	Flange Width (B)	Dia. of Bolt Circle (C)	Dia. of Bolt Holes	No. of Bolts	Dia. of Bolts	Length of Bolts (D) (2)		
								Stud Bolts		Machine Bolts
								Raised Face .06 in	Ring Joint	Raised Face .06 in
1/2	3.50	0.38	2.38	5/8	4	1/2	2.25	---	2.00	
3/4	3.88	0.44	2.75	5/8	4	1/2	2.50	---	2.00	
1	4.25	0.50	3.12	5/8	4	1/2	2.50	3.00	2.25	
1 1/4	4.62	0.56	3.50	5/8	4	1/2	2.75	3.25	2.25	
1 1/2	5.00	0.62	3.88	5/8	4	1/2	2.75	3.25	2.50	
2	6.00	0.69	4.75	3/4	4	5/8	3.25	3.75	2.75	
2 1/2	7.00	0.81	5.50	3/4	4	5/8	3.50	4.00	3.00	
3	7.50	0.88	6.00	3/4	4	5/8	3.50	4.00	3.00	
4	9.00	0.88	7.50	3/4	8	5/8	3.50	4.00	3.00	
5	10.00	0.88	8.50	7/8	8	3/4	3.75	4.25	3.25	
6	11.00	0.94	9.50	7/8	8	3/4	4.00	4.50	3.25	
8	13.50	1.06	11.75	7/8	8	3/4	4.25	4.75	3.50	
10	16.00	1.12	14.25	1	12	7/8	4.50	5.00	4.00	
12	19.00	1.19	17.00	1	12	7/8	4.75	5.25	4.00	
14	21.00	1.31	18.75	1 1/8	12	1	5.25	5.75	4.50	
16	23.50	1.38	21.25	1 1/8	16	1	5.25	5.75	4.50	
18	25.00	1.50	22.75	1 1/4	16	1 1/8	5.75	6.25	5.00	
20	27.50	1.69	25.00	1 1/4	20	1 1/8	6.25	6.75	5.50	
24	32.00	1.81	29.50	1 3/8	20	1 1/4	6.75	7.25	6.00	

CLASS 600 FLANGES	Pipe Size	Dia. of Flange (A)	Flange Width (B)	Dia. of Bolt Circle (C)	Dia. of Bolt Holes	No. of Bolts	Dia. of Bolts	Length of Stud Bolts (D) (2)		
								Raised Face .25 in	Male & Female/Tongue & Groove	Ring Joint
								1/2	3.75	0.56
3/4	4.62	0.62	3.25	3/4	4	5/8	3.50	3.25	3.50	
1	4.88	0.69	3.50	3/4	4	5/8	3.50	3.25	3.50	
1 1/4	5.25	0.81	3.88	3/4	4	5/8	3.75	3.50	3.75	
1 1/2	6.12	0.88	4.50	7/8	4	3/4	4.25	4.00	4.25	
2	6.50	1.00	5.00	3/4	8	5/8	4.25	4.00	4.25	
2 1/2	7.50	1.12	5.88	7/8	8	3/4	4.75	4.50	4.75	
3	8.25	1.25	6.62	7/8	8	3/4	5.00	4.75	5.00	
4	10.75	1.50	8.50	1	8	7/8	5.75	5.50	5.75	
5	13.00	1.75	10.50	1 1/8	8	1	6.50	6.25	6.50	
6	14.00	1.88	11.50	1 1/8	12	1	6.75	6.50	6.75	
8	16.50	2.19	13.75	1 1/4	12	1 1/8	7.50	7.25	7.75	
10	20.00	2.50	17.00	1 3/8	16	1 1/4	8.50	8.25	8.50	
12	22.00	2.62	19.25	1 3/8	20	1 1/4	8.75	8.50	8.75	
14	23.75	2.75	20.75	1 1/2	20	1 3/8	9.25	9.00	9.25	
16	27.00	3.00	23.75	1 5/8	20	1 1/2	10.00	9.75	10.00	
18	29.25	3.25	25.75	1 3/4	20	1 5/8	10.75	10.50	10.75	
20	32.00	3.50	28.50	1 3/4	24	1 5/8	11.25	11.00	11.50	
24	37.00	4.00	33.00	2	24	1 7/8	13.00	12.75	13.25	

CLASS 250 & 300 FLANGES (3)	Pipe Size	Dia. of Flange (A)	Flange Width (B)	Dia. of Bolt Circle (C)	Dia. of Bolt Holes	No. of Bolts	Dia. of Bolts	Length of Bolts (D) (2)		
								Stud Bolts		Machine Bolts
								Raised Face .06 in	Ring Joint	Raised Face .06 in
1/2	3.75	0.50	2.62	5/8	4	1/2	2.50	3.00	2.25	
3/4	4.62	0.56	3.25	3/4	4	5/8	3.00	3.50	2.50	
1	4.88	0.62	3.50	3/4	4	5/8	3.00	3.50	2.50	
1 1/4	5.25	0.69	3.88	3/4	4	5/8	3.25	3.75	2.75	
1 1/2	6.12	0.75	4.50	7/8	4	3/4	3.50	4.00	3.00	
2	6.50	0.81	5.00	3/4	8	5/8	3.50	4.00	3.00	
2 1/2	7.50	0.94	5.88	7/8	8	3/4	4.00	4.50	3.25	
3	8.25	1.06	6.62	7/8	8	3/4	4.25	4.75	3.50	
4	10.00	1.19	7.88	7/8	8	3/4	4.50	5.00	3.75	
5	11.00	1.31	9.25	7/8	8	3/4	4.75	5.25	4.25	
6	12.50	1.38	10.62	7/8	12	3/4	4.75	5.50	4.25	
8	15.00	1.56	13.00	1	12	7/8	5.50	6.00	4.75	
10	17.50	1.81	15.25	1 1/8	16	1	6.25	6.75	5.50	
12	20.50	1.94	17.75	1 1/4	16	1 1/8	6.75	7.25	5.75	
14	23.00	2.06	20.25	1 1/4	20	1 1/8	7.00	7.50	6.25	
16	25.50	2.19	22.50	1 3/8	20	1 1/4	7.50	8.00	6.50	
18	28.00	2.31	24.75	1 3/8	24	1 1/4	7.75	8.25	6.75	
20	30.50	2.44	27.00	1 3/8	24	1 1/4	8.00	8.75	7.25	
24	36.00	2.69	32.00	1 5/8	24	1 1/2	9.00	10.00	8.00	

CLASS 900 FLANGES	Pipe Size	Dia. of Flange (A)	Flange Width (B)	Dia. of Bolt Circle (C)	Dia. of Bolt Holes	No. of Bolts	Dia. of Bolts	Length of Stud Bolts (D) (2)		
								Raised Face .25 in	Male & Female/Tongue & Groove	Ring Joint
								1/2	4.75	0.88
3/4	5.12	1.00	3.50	7/8	4	3/4	4.50	4.25	4.50	
1	5.88	1.12	4.00	1	4	7/8	5.00	4.75	5.00	
1 1/4	6.25	1.12	4.38	1	4	7/8	5.00	4.75	5.00	
1 1/2	7.00	1.25	4.88	1 1/8	4	1	5.50	5.25	5.50	
2	8.50	1.50	6.50	1	8	7/8	5.75	5.50	5.75	
2 1/2	9.62	1.62	7.50	1 1/8	8	1	6.25	6.00	6.25	
3	9.50	1.50	7.50	1	8	7/8	5.75	5.50	5.75	
4	11.50	1.75	9.25	1 1/4	8	1 1/8	6.75	6.50	6.75	
5	13.75	2.00	11.00	1 3/8	8	1 1/4	7.50	7.25	7.50	
6	15.00	2.19	12.50	1 1/4	12	1 1/8	7.50	7.25	7.75	
8	18.50	2.50	15.50	1 1/2	12	1 3/8	8.75	8.50	8.75	
10	21.50	2.75	18.50	1 1/2	16	1 3/8	9.25	9.00	9.25	
12	24.00	3.12	21.00	1 1/2	20	1 3/8	10.00	9.75	10.00	
14	25.25	3.38	22.00	1 5/8	20	1 1/2	10.75	10.50	11.00	
16	27.75	3.50	24.25	1 3/4	20	1 5/8	11.25	11.00	11.50	
18	31.00	4.00	27.00	2	20	1 7/8	12.75	12.50	13.25	
20	33.75	4.25	29.50	2 1/8	20	2	13.75	13.50	14.25	
24	41.00	5.50	35.50	2 5/8	20	2 1/2	17.25	17.00	18.00	

- Flange width 'B' dimension does not include raised face.
- Bolt length 'D' does not include point height.
- Cast Iron Class 125 & 250 have the same bolting pattern as Class 150 & 300, respectively. The only difference is Cast Iron flanges are flat faced and are 1/16 inch thicker.
- Class 150 and 300 Flanged Strainers are regularly furnished with 1/16 inch high raised face.
- Class 600 and higher Flanged Strainers are regularly furnished with 1/4 inch high raised face.
- Facing per ANSI/MSS SP-6.
- Machine and Stud Bolt Lengths are based upon mating raised face flanges not RTJ flanges.

Titan FCI makes every effort to ensure the information presented on our literature accurately reflects exact product specifications. However, as product changes occur, there may be short-term differences between actual product specifications and the information contained within our literature. Titan FCI reserves the right to make design and specification changes to improve our products without prior notification.

When required, request certified drawings.

TITAN FLOW CONTROL, INC.

Tel: 910-735-0000 ♦ Fax: 910-738-3848 ♦ titan@titanfci.com ♦ www.titanfci.com
290 Corporate Drive ♦ PO Box 7408 ♦ Lumberton, NC 28358



TEMPLATES FOR DRILLING & PRESSURE/TEMPERATURE RATINGS

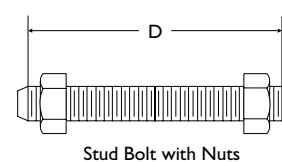
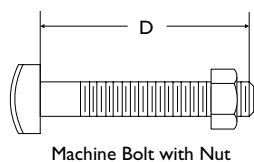
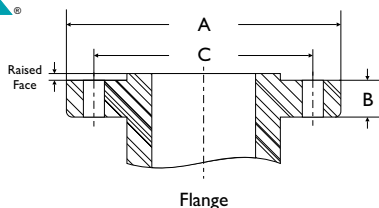

CLASS 1500 FLANGES	Pipe Size	Dia. of Flange (A)	Flange Width ⁽¹⁾ (B)	Dia. of Bolt Circle (C)	Dia. of Bolt Holes	No. of Bolts	Dia. of Bolts	Length of Stud Bolts (D) ⁽²⁾		
								Raised Face .25 in	Male & Female/Tongue & Groove	Ring Joint
1/2	4.75	0.88	3.25	7/8	4	3/4	4.25	4.00	4.25	
3/4	5.12	1.00	3.50	7/8	4	3/4	4.50	4.25	4.50	
1	5.88	1.12	4.00	1	4	7/8	5.00	4.75	5.00	
1 1/4	6.25	1.12	4.38	1	4	7/8	5.00	4.75	5.00	
1 1/2	7.00	1.25	4.88	1 1/8	4	1	5.50	5.25	5.50	
2	8.50	1.50	6.50	1	8	7/8	5.75	5.50	5.75	
2 1/2	9.62	1.62	7.50	1 1/8	8	1	6.25	6.00	6.25	
3	10.50	1.88	8.00	1 1/4	8	1 1/8	7.00	6.75	7.00	
4	12.25	2.12	9.50	1 3/8	8	1 1/4	7.75	7.50	7.75	
5	14.75	2.88	11.50	1 5/8	8	1 1/2	9.75	9.50	9.75	
6	15.50	3.25	12.50	1 1/2	12	1 3/8	10.25	10.00	10.50	
8	19.00	3.62	15.50	1 3/4	12	1 5/8	11.50	11.25	12.75	
10	23.00	4.25	19.00	2	12	1 7/8	13.25	13.00	13.50	
12	26.50	4.88	22.50	2 1/8	16	2	14.75	14.50	15.25	
14	29.50	5.25	25.00	2 3/8	16	2 1/4	16.00	15.75	16.75	
16	32.50	5.75	27.75	2 5/8	16	2 1/2	17.50	17.25	18.50	
18	36.00	6.38	30.50	2 7/8	16	2 3/4	19.50	19.25	20.75	
20	38.75	7.00	32.75	3 1/8	16	3	21.25	21.00	22.25	
24	46.00	8.00	39.00	3 5/8	16	3 1/2	24.25	24.00	25.50	

CLASS 2500 FLANGES	Pipe Size	Dia. of Flange (A)	Flange Width ⁽¹⁾ (B)	Dia. of Bolt Circle (C)	Dia. of Bolt Holes	No. of Bolts	Dia. of Bolts	Length of Stud Bolts (D) ⁽²⁾		
								Raised Face .25 in	Male & Female/Tongue & Groove	Ring Joint
1/2	5.25	1.19	3.50	7/8	4	3/4	4.75	4.50	4.75	
3/4	5.50	1.25	3.75	7/8	4	3/4	5.00	4.75	5.00	
1	6.25	1.38	4.25	1	4	7/8	5.50	5.25	5.50	
1 1/4	7.25	1.50	5.12	1 1/8	4	1	6.00	5.75	6.00	
1 1/2	8.00	1.75	5.75	1 1/4	4	1 1/8	6.75	6.50	6.75	
2	9.25	2.00	6.75	1 1/8	8	1	7.00	6.75	7.00	
2 1/2	10.50	2.25	7.75	1 1/4	8	1 1/8	7.75	7.50	8.00	
3	12.00	2.62	9.00	1 3/8	8	1 1/4	8.75	8.50	9.00	
4	14.00	3.00	10.75	1 5/8	8	1 1/2	10.00	9.75	10.25	
5	16.50	3.62	12.75	1 7/8	8	1 3/4	11.75	11.50	12.25	
6	19.00	4.25	14.50	2 1/8	8	2	13.50	13.25	14.00	
8	21.75	5.00	17.25	2 1/8	12	2	15.00	14.75	15.50	
10	26.50	6.50	21.25	2 5/8	12	2 1/2	19.25	19.00	20.00	
12	30.00	7.25	24.38	2 7/8	12	2 3/4	21.25	21.00	22.00	
14	---	---	---	---	---	---	---	---	---	
16	---	---	---	---	---	---	---	---	---	
18	---	---	---	---	---	---	---	---	---	
20	---	---	---	---	---	---	---	---	---	
24	---	---	---	---	---	---	---	---	---	

ANSI PRESSURE AND TEMPERATURE RATINGS	Material	End Connection	Pressure Class	WOG (water, oil, gas)	Max Saturated Steam	Max Liquid
	Cast Iron	Threaded	ANSI 250	400 psi @ 150 °F	250 psi @ 406 °F	250 psi @ 406 °F
Cast Iron: 2" - 12"	Flanged	ANSI 125	200 psi @ 150 °F	125 psi @ 353 °F	125 psi @ 450 °F	
Cast Iron: 14" - 24"	Flanged	ANSI 125	150 psi @ 150 °F	100 psi @ 353 °F	100 psi @ 353 °F	
Cast Iron: 2" - 12"	Flanged	ANSI 250	500 psi @ 150 °F	250 psi @ 406 °F	250 psi @ 450 °F	
Cast Iron: 14" - 24"	Flanged	ANSI 250	300 psi @ 150 °F	200 psi @ 387 °F	200 psi @ 406 °F	
Ductile Iron	Flanged	ANSI 150	250 psi @ 100 °F	150 psi @ 366 °F	125 psi @ 650 °F	
Ductile Iron	Flanged	ANSI 300	640 psi @ 100 °F	300 psi @ 420 °F	450 psi @ 650 °F	
Bronze	Threaded	ANSI 125	200 psi @ 150 °F	125 psi @ 353 °F	125 psi @ 400 °F	
Bronze	Threaded	ANSI 250	400 psi @ 150 °F	250 psi @ 406 °F	250 psi @ 400 °F	
Bronze	Flanged	ANSI 150	225 psi @ 150 °F	150 psi @ 366 °F	135 psi @ 406 °F	
Bronze	Flanged	ANSI 300	500 psi @ 150 °F	300 psi @ 420 °F	280 psi @ 406 °F	
Carbon Steel	Threaded & Socket Weld	ANSI 300	740 psi @ 100 °F	300 psi @ 420 °F	400 psi @ 800 °F	
Carbon Steel	Threaded & Socket Weld	ANSI 600	1480 psi @ 100 °F	600 psi @ 489 °F	825 psi @ 800 °F	
Carbon Steel	Threaded & Socket Weld	ANSI 1500	3705 psi @ 100 °F	1500 psi @ 603 °F	2060 psi @ 800 °F	
Carbon Steel	Flanged & Butt Weld	ANSI 150	285 psi @ 100 °F	150 psi @ 366 °F	80 psi @ 800 °F	
Carbon Steel	Flanged & Butt Weld	ANSI 300	740 psi @ 100 °F	300 psi @ 420 °F	400 psi @ 800 °F	
Carbon Steel	Flanged & Butt Weld	ANSI 600	1480 psi @ 100 °F	600 psi @ 489 °F	825 psi @ 800 °F	
Carbon Steel	Flanged & Butt Weld	ANSI 900	2220 psi @ 100 °F	900 psi @ 534 °F	1225 psi @ 800 °F	
Carbon Steel	Flanged & Butt Weld	ANSI 1500	3705 psi @ 100 °F	1500 psi @ 603 °F	2060 psi @ 800 °F	
Carbon Steel	Flanged & Butt Weld	ANSI 2500	6170 psi @ 100 °F	2500 psi @ 673 °F	3430 psi @ 800 °F	
Stainless Steel	Threaded & Socket Weld	ANSI 300	720 psi @ 100 °F	300 psi @ 420 °F	350 psi @ 1000 °F	
Stainless Steel	Threaded & Socket Weld	ANSI 600	1440 psi @ 100 °F	600 psi @ 489 °F	700 psi @ 1000 °F	
Stainless Steel	Threaded & Socket Weld	ANSI 1500	3600 psi @ 100 °F	1500 psi @ 603 °F	1750 psi @ 1000 °F	
Stainless Steel	Flanged & Butt Weld	ANSI 150	275 psi @ 100 °F	150 psi @ 366 °F	20 psi @ 1000 °F	
Stainless Steel	Flanged & Butt Weld	ANSI 300	720 psi @ 100 °F	300 psi @ 420 °F	350 psi @ 1000 °F	
Stainless Steel	Flanged & Butt Weld	ANSI 600	1440 psi @ 100 °F	600 psi @ 489 °F	700 psi @ 1000 °F	
Stainless Steel	Flanged & Butt Weld	ANSI 900	2160 psi @ 100 °F	900 psi @ 534 °F	1050 psi @ 1000 °F	
Stainless Steel	Flanged & Butt Weld	ANSI 1500	3600 psi @ 100 °F	1500 psi @ 603 °F	1750 psi @ 1000 °F	
Stainless Steel	Flanged & Butt Weld	ANSI 2500	6000 psi @ 100 °F	2500 psi @ 673 °F	2915 psi @ 1000 °F	

TITAN FLOW CONTROL, INC.

Tel: 910-735-0000 ♦ Fax: 910-738-3848 ♦ titan@titanfci.com ♦ www.titanfci.com
 290 Corporate Drive ♦ PO Box 7408 ♦ Lumberton, NC 28358



TITAN FLOW CONTROL, INC.

"Y" (WYE) STRAINER ♦ ANSI CLASS 250

CAST IRON ♦ THREADED ENDS

MODEL: **YS 12-CI**
(CAST IRON)



3" YS 12-CI

FEATURES

SIZE RANGE : 1/4" ~ 3"

- ♦ **LARGE STRAINING CAPACITY**
WITH ITS LARGE BODY AND SIZABLE STRAINING ELEMENT, THE YS12 PROVIDES EXCELLENT OPEN AREA RATIOS THAT ARE TYPICALLY TWO-AND-A-HALF TIMES LARGER THAN THE CORRESPONDING PIPELINE.
- ♦ **PRECISION MACHINED SEATS**
PRECISION MACHINED SCREEN SEATS IN BOTH THE BODY AND CAP HELP TO ENSURE ACCURATE POSITIONING OF THE SCREEN DURING REASSEMBLY AFTER CLEANING. ALSO, THE MACHINED BODY SEATS ENABLE FINER FILTRATION BY PREVENTING DEBRIS BYPASS.
- ♦ **SELF-CLEANING CAPABILITY**
WITH A TAPPED NPT BLOW-OFF CONNECTION, THIS UNIT CAN BE FITTED WITH A BLOW-DOWN VALVE WHICH FACILITATES CLEANING OF THE STRAINING ELEMENT. PLEASE CONTACT FACTORY FOR MORE INFORMATION.
- ♦ **EPOXY PAINTED**
ALL UNITS ARE EPOXY PAINTED TO HELP RESIST RUST AND CORROSION. TITAN FCI ALSO OFFERS EPOXY COATING AS AN OPTION FOR THE YS12.
- ♦ **POTABLE WATER/FDA APPROVED COATINGS AVAILABLE**

 IN ADDITION TO ITS LEAD FREE, CAST IRON BODY, TITAN CAN PROVIDE NSF/ANSI AND FDA APPROVED EPOXY COATINGS WHICH MAKE THIS PRODUCT SUITABLE FOR POTABLE WATER AND FOOD CONTACT APPLICATIONS. NUMEROUS OPTIONS ARE AVAILABLE. PLEASE CONTACT US FOR MORE DETAILS.
- ♦ **THREADED CAP**
TITAN'S YS12 HAS STRAIGHT THREADS TO PERMIT EASY CAP REMOVAL FOR CLEANING AND PROPER ALIGNMENT WHEN REASSEMBLING STRAINER.
- ♦ **NATURAL GAS AND OTHER SPECIAL APPLICATIONS**
TITAN HAS EXTENSIVELY TESTED THE YS12 IN GAS APPLICATIONS AND DETERMINED THAT BUNA-N GASKETS PROVIDE SUPERB SEALING CAPABILITIES FOR THE SERVICE. ALWAYS SPECIFY IF A SPECIAL GASKET OR SCREEN IS REQUIRED FOR A SPECIFIC APPLICATION.

TECHNICAL

PRESSURE/TEMPERATURE RATING
CI-ASTMA126 GR. B - CLASS 250
YS 12-CI (THREADED)

WOG (Non-shock): 400 PSI @ 150 °F

- *The above listed temperatures are theoretical and may vary during actual operating conditions.*

APPLICATIONS

GENERAL APPLICATION: Y-STRAINERS ARE INSTALLED IN A PIPING SYSTEM TO REMOVE UNWANTED DEBRIS FROM THE PIPELINE, PROTECTING EXPENSIVE EQUIPMENT DOWNSTREAM SUCH AS PUMPS, METERS, SPRAY NOZZLES, COMPRESSORS, AND TURBINES. THEY CAN BE PLACED IN A HORIZONTAL OR VERTICAL PIPELINE AS LONG AS THE SCREEN IS IN A DOWNWARD POSITION. STRAINING IS ACCOMPLISHED VIA AN INTERNAL PERFORATED OR MESH LINED STRAINING ELEMENT, THE SIZE OF WHICH SHOULD BE DETERMINED BASED ON THE SIZE OF THE SMALLEST PARTICLE TO BE REMOVED.

SERVICING: THE STRAINING ELEMENT NEEDS REGULAR CLEANING TO PREVENT DEBRIS BUILD UP. IT IS NOT ADVISABLE TO ALLOW THE DIFFERENTIAL PRESSURE TO INCREASE BY 20 PSI. ALTHOUGH CLEANING NORMALLY REQUIRES THE REMOVAL OF THE STRAINING ELEMENT, INSTALLING AND USING A TITAN BLOW-OFF DRAIN VALVE CAN INCREASE THE TIME BETWEEN CLEANINGS.

The above data represents common market and service applications. No representation or guarantee, expressed or implied, is given due to the numerous variations of concentrations, temperatures and flow conditions that may occur during actual service.

TITAN FLOW CONTROL, INC.

YOUR PIPELINE TO THE FUTURE!

Tel: 910-735-0000 ♦ Fax: 910-738-3848 ♦ titan@titanfci.com ♦ www.titanfci.com
290 Corporate Drive ♦ PO Box 7408 ♦ Lumberton, NC 28358



TITAN FLOW CONTROL, Inc.
 290 Corporate Drive
 Lumberton, NC 28358
 Tel: 910.735.0000
 E-mail: titan@titanfci.com
 Web: www.titanfci.com
 Fax: 910.738.3848

"Y" (WYE) STRAINER
YS 12-CI - (Cast Iron)
 Threaded Ends • Cast Iron • ANSI Class 250

ANSI Class
 250

BILL OF MATERIALS (1)

No.	PART	YS 12-CI
1	Body (2)	Cast Iron A126 Gr. B
2	Cap	Cast Iron A126 Gr. B
3	Straining Element (3)	Stainless Steel (6)
4	Gasket (3) (4)	Grafoil
5	NPT Plug (Blow-off) (5)	Steel

- Bill of Materials represents standard materials. Equivalent or better materials may be substituted at the manufacturer's discretion.
- All units are epoxy painted.
- Denotes recommended spare parts.
- Contact Titan for special gaskets materials, including Buna-N or Viton, for natural gas, hot air, or other applications.
- The YS12 can be furnished with bronze blow-off plug to meet Military Specification WW-S-2739. Contact factory.
- Stainless Steel Straining Element is available in Type 304 and Type 316 Stainless Steel. A wide range of wire mesh and perforated screens are available. See "Standard Screen Selections" chart below for standard perforations and meshes. Please specify if a non-standard screen is required.

Illustrations are representative of a 2" YS12-CI.
 Please ask for certified drawings when required.

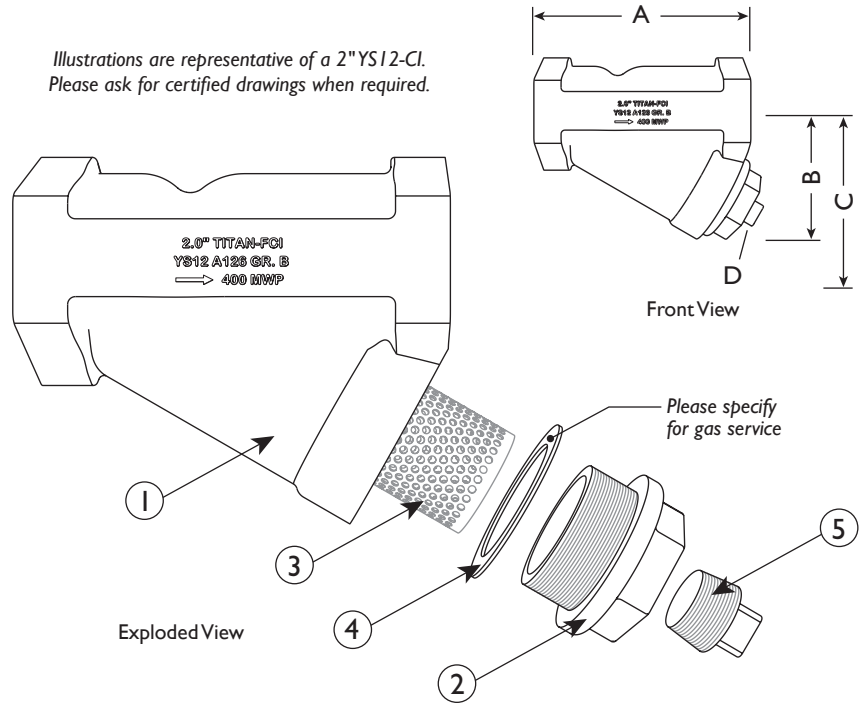

DIMENSIONS AND PERFORMANCE DATA (1)

SIZE	in	1/4	3/8	1/2	3/4	1	1 1/4	1 1/2	2	2 1/2	3
	mm	8	10	15	20	25	32	40	50	65	80
A DIMENSION FACE TO FACE (2)	in	3.188	3.188	3.188	3.75	4.2	5.0	5.75	7.0	9.25	10.0
	mm	81	81	81	95	107	127	146	178	235	254
B DIMENSION CENTER LINE TO BOTTOM	in	2.063	2.063	2.063	2.438	2.625	3.375	3.875	4.75	5.875	6.0
	mm	52	52	52	62	67	86	98	121	149	152
C DIMENSION SCREEN REMOVAL	in	2.375	2.375	2.375	3.0	3.25	4.25	5.0	6.125	7.875	8.0
	mm	60	60	60	76	83	108	127	156	200	203
D NPT Plug BLOW-OFF	in	1/4	1/4	1/4	3/8	3/8	3/4	3/4	1	1 1/2	1 1/2
	mm	8	8	8	10	10	20	20	25	40	40
APPROXIMATE ASSEMBLED WEIGHT	lb	1.5	1.5	1.5	2.5	3.5	6.0	9.0	14.0	25.5	32.0
	kg	0.7	0.7	0.7	1.1	1.6	2.7	4.1	6.3	11.6	14.5
Flow Coefficient	C _v	0.7	2	8	15	22	38	42	70	110	160

- Dimensions and weights are for reference only. When required, request certified drawings.
- Face to face values have a tolerance of ±0.06 in (±2.0 mm).

PRESSURE - TEMPERATURE RATINGS

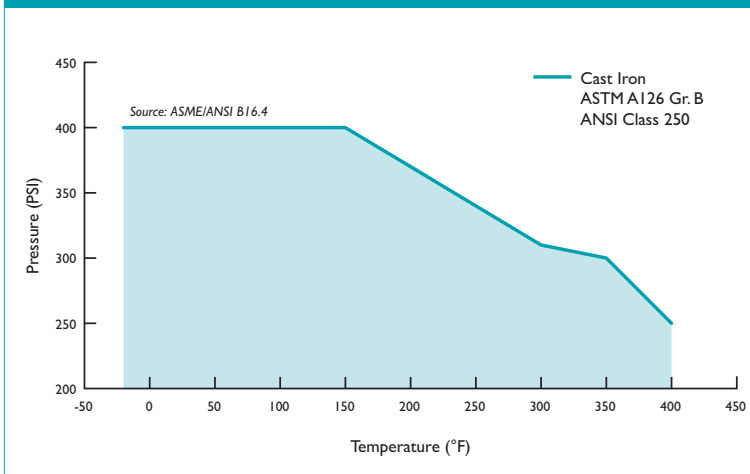

PRESSURE - TEMPERATURE RATING

ANSI Class 250	A126 Gr. B
WOG (Non-shock):	400 PSI @ 150 °F

STANDARD SCREEN SELECTIONS

Size	Liquid	Open Area	Steam	Open Area
1/4" ~ 2"	20 Mesh	51.8%	30 Mesh	44.8%
2 1/2" ~ 3"	1/16 (.0625)	41%	3/64 (.045)	36%

REFERENCED STANDARDS & CODES

CODE	DESCRIPTION
ASME/ANSI B16.4	Cast Iron Threaded Fittings

Titan FCI makes every effort to ensure the information presented on our literature accurately reflects exact product specifications. However, as product changes occur, there may be short-term differences between actual product specifications and the information contained within our literature. Titan FCI reserves the right to make design and specification changes to improve our products without prior notification. When required, request certified drawings.



TITAN FLOW CONTROL, INC.

"Y" (WYE) STRAINER ♦ ANSI CLASS 300 DUCTILE IRON ♦ THREADED ENDS

MODEL: **YS 12-DI**
(DUCTILE IRON)

IMPROVED DESIGN...

INCREASED TEMPERATURE
RATING PER
ASTM A395

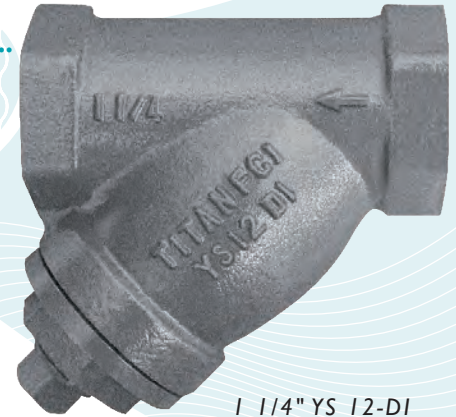

1 1/4" YS 12-DI

FEATURES

SIZE RANGE : 1/4" ~ 3"

- ♦ **ENHANCED DESIGN**
IMPROVED 45° 'Y' ANGLE PROVIDES STRONGER CASTING, THUS ELIMINATING FIELD PROBLEMS. ALSO, THE NEW DUCTILE IRON MATERIAL OFFERS EXCELLENT LONG TERM ABRASION AND WEAR RESISTANCE, AND IS BETTER SUITED FOR ELEVATED TEMPERATURES PER ASTM A395.
- ♦ **PRECISION MACHINED SEATS**
PRECISION MACHINED TAPERED SCREEN SEAT AND CAST IN RIB GUIDES HELP ENSURE ACCURATE POSITIONING OF THE SCREEN DURING REASSEMBLY AFTER CLEANING. ALSO, THE MACHINED BODY SEATS ENABLE FINER FILTRATION BY PREVENTING DEBRIS BYPASS.
- ♦ **SELF-CLEANING CAPABILITY**
WITH A TAPPED NPT BLOW-OFF CONNECTION, THIS UNIT CAN BE FITTED WITH A BLOW-DOWN VALVE WHICH FACILITATES CLEANING OF THE STRAINING ELEMENT. PLEASE CONTACT FACTORY FOR MORE INFORMATION.
- ♦ **EPOXY PAINTED**
ALL UNITS ARE EPOXY PAINTED TO HELP RESIST RUST AND CORROSION. TITAN FCI ALSO OFFERS EPOXY COATING AS AN OPTION FOR THE YS12.
- ♦ **POTABLE WATER/FDA APPROVED COATINGS AVAILABLE**
IN ADDITION TO ITS LEAD FREE, DUCTILE IRON BODY, TITAN CAN PROVIDE NSF/ANSI AND FDA APPROVED EPOXY COATINGS WHICH MAKE THIS PRODUCT SUITABLE FOR POTABLE WATER AND FOOD CONTACT APPLICATIONS. NUMEROUS OPTIONS ARE AVAILABLE. PLEASE CONTACT US FOR MORE DETAILS.
- ♦ **THREADED CAP**
TITAN'S YS12 HAS STRAIGHT THREADS TO PERMIT EASY CAP REMOVAL FOR CLEANING AND PROPER ALIGNMENT WHEN REASSEMBLING STRAINER.
- ♦ **NATURAL GAS AND OTHER SPECIAL APPLICATIONS**
TITAN HAS EXTENSIVELY TESTED THE YS12 IN GAS APPLICATIONS AND DETERMINED THAT BUNA-N GASKETS PROVIDE SUPERB SEALING CAPABILITIES FOR THE SERVICE. ALWAYS SPECIFY IF A SPECIAL GASKET OR SCREEN IS REQUIRED FOR A SPECIFIC APPLICATION.



TECHNICAL

PRESSURE/TEMPERATURE RATING ⁽¹⁾
DUCTILE IRON - ASTM A395 - CLASS 300
YS 12-DI (THREADED)

WOG (Non-Shock): 640 PSI @ 100 °F

- The above listed temperatures are theoretical and may vary during actual operating conditions.

APPLICATIONS

GENERAL APPLICATION: Y-STRAINERS ARE INSTALLED IN A PIPING SYSTEM TO REMOVE UNWANTED DEBRIS FROM THE PIPELINE, PROTECTING EXPENSIVE EQUIPMENT DOWNSTREAM SUCH AS PUMPS, METERS, SPRAY NOZZLES, COMPRESSORS, AND TURBINES. THEY CAN BE PLACED IN A HORIZONTAL OR VERTICAL PIPELINE AS LONG AS THE SCREEN IS IN A DOWNWARD POSITION. STRAINING IS ACCOMPLISHED VIA AN INTERNAL PERFORATED OR MESH LINED STRAINING ELEMENT, THE SIZE OF WHICH SHOULD BE DETERMINED BASED ON THE SIZE OF THE SMALLEST PARTICLE TO BE REMOVED.

SERVICING: THE STRAINING ELEMENT NEEDS REGULAR CLEANING TO PREVENT DEBRIS BUILD UP. IT IS NOT ADVISABLE TO ALLOW THE DIFFERENTIAL PRESSURE TO INCREASE BY 20 PSI. ALTHOUGH CLEANING NORMALLY REQUIRES THE REMOVAL OF THE STRAINING ELEMENT, INSTALLING AND USING A TITAN BLOW-OFF DRAIN VALVE CAN INCREASE THE TIME BETWEEN CLEANINGS.

The above data represents common market and service applications. No representation or guarantee, expressed or implied, is given due to the numerous variations of concentrations, temperatures and flow conditions that may occur during actual service.

TITAN FLOW CONTROL, INC.
YOUR PIPELINE TO THE FUTURE!

Tel: 910-735-0000 ♦ Fax: 910-738-3848 ♦ titan@titanfci.com ♦ www.titanfci.com
290 Corporate Drive ♦ PO Box 7408 ♦ Lumberton, NC 28358



TITAN FLOW CONTROL, Inc.

290 Corporate Drive
Lumberton, NC 28358
Tel: 910.735.0000

E-mail: titan@titanfci.com
Web: www.titanfci.com
Fax: 910.738.3848

"Y" (WYE) STRAINER

YS 12-DI - (Ductile Iron)

Threaded Ends • Ductile Iron • ANSI Class 300

ANSI Class
300

BILL OF MATERIALS ⁽¹⁾

No.	PART	YS 12-DI
1	Body ⁽²⁾	Ductile Iron ASTM A395
2	Cap	Ductile Iron ASTM A395
3	Straining Element ^{(3) (5)}	Stainless Steel
4	Gasket ^{(3) (4)}	Grafoil
5	NPT Plug (Blow-off)	Steel

1. Bill of Materials represents standard materials. Equivalent or better materials may be substituted at the manufacturer's discretion.
2. All units are epoxy painted.
3. Denotes recommended spare parts.
4. Contact Titan for special gaskets materials, including Buna-N or Viton, for natural gas, hot air, or other applications.
5. Stainless Steel Straining Element is available in Type 304 and Type 316 Stainless Steel. A wide range of wire mesh and perforated screens are available. See "Standard Screen Selections" chart below for standard perforations and meshes. Please specify if a non-standard screen is required.

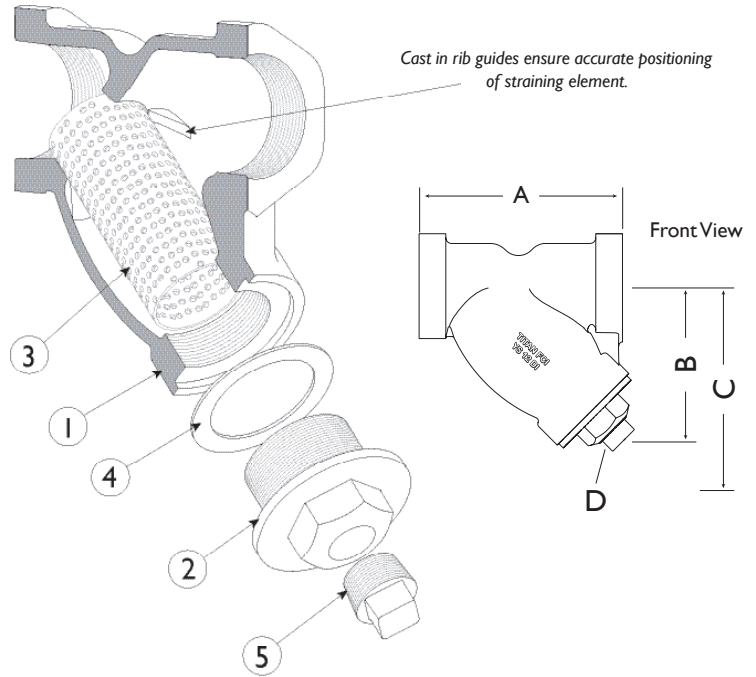

Illustrations are representative of a 2" YS12-DI. Please ask for certified drawings when required.

DIMENSIONS AND PERFORMANCE DATA ⁽¹⁾

SIZE	in	1/4	3/8	1/2	3/4	1	1 1/4	1 1/2	2	2 1/2	3
	mm	8	10	15	20	25	32	40	50	65	80
A DIMENSION FACE TO FACE ⁽²⁾	in	3.21	3.21	3.21	3.75	4.03	5.04	5.81	7.04	9.20	10.02
	mm	82	82	82	95	103	128	148	179	234	255
B DIMENSION CENTER LINE TO BOTTOM	in	2.10	2.10	2.10	3.04	3.52	3.71	4.25	5.67	7.25	7.25
	mm	54	54	54	77	90	94	108	144	184	184
C DIMENSION SCREEN REMOVAL	in	2.70	2.70	2.70	4.05	4.85	5.22	6.43	8.25	10.97	10.97
	mm	69	69	69	103	123	133	163	210	279	279
D NPT Plug BLOW-OFF	in	1/4	1/4	1/4	3/8	3/8	3/4	3/4	1	1 1/2	1 1/2
	mm	8	8	8	10	10	20	20	25	40	40
APPROXIMATE ASSEMBLED WEIGHT	lb	1.5	1.5	1.25	2.6	3.5	5.2	7.5	12.9	25.5	28.5
	kg	0.7	0.7	0.6	1.2	1.6	2.4	3.4	5.9	11.6	12.9
Flow Coefficient	C _v	2	2	8	15	22	38	42	70	110	160

1. Dimensions and weights are for reference only. When required, request certified drawings.
2. Face to face values have a tolerance of ±0.06 in (±2.0 mm).

PRESSURE - TEMPERATURE RATINGS ⁽¹⁾

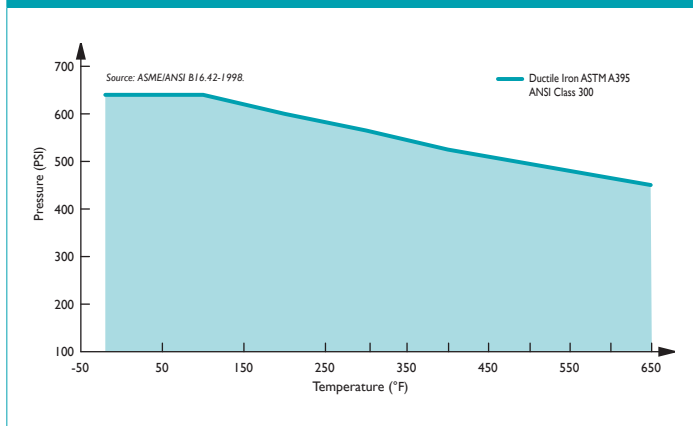

PRESSURE - TEMPERATURE RATING

ANSI CLASS 300	ASTM A395
WOG (Non-Shock)	640 PSI @ 100 °F

STANDARD SCREEN SELECTIONS

Size	Liquid	Open Area	Steam	Open Area
1/4" ~ 2"	20 Mesh	51.8%	30 Mesh	44.8%
2 1/2" ~ 3"	1/16 (.0625)	41%	3/64 (.045)	36%

REFERENCED STANDARDS & CODES

CODE	DESCRIPTION
ASME/ANSI B16.42	Ductile Iron Pipe Flanges and Flanged Fittings

Titan FCI makes every effort to ensure the information presented on our literature accurately reflects exact product specifications. However, as product changes occur, there may be short-term differences between actual product specifications and the information contained within our literature. Titan FCI reserves the right to make design and specification changes to improve our products without prior notification. When required, request certified drawings.



TITAN FLOW CONTROL, INC.

"Y" (WYE) STRAINER ♦ ANSI CLASS 125 CAST IRON ♦ FLANGED ENDS, FLAT FACE

NEWLY DESIGNED...
Gauge Taps

STANDARD ON ALL
YS 58-CI MODELS IN
SIZES 2" ~ 20"



MODELS: **YS 58-CI**
(CAST IRON)

FEATURES

SIZE RANGE : 2" ~ 24"

♦ NEW DESIGN WITH GAUGE TAPS

TITAN'S YS58 HAS CONVENIENT GAUGE TAPS FURNISHED WITH A PLUG ON BOTH THE INLET AND OUTLET SIDES OF SIZES 2" THROUGH 20". THESE TAPS ALLOW FOR EASY INSTALLATION OF PRESSURE GAUGES TO MONITOR DIFFERENTIAL PRESSURE AND DETERMINE WHEN SCREEN CLEANING IS NECESSARY. ADDITIONALLY, SIZES 2" THROUGH 6" HAVE AN EXTRA BOSS FOR CUSTOM GAUGE TAPPING.

♦ LARGE STRAINING CAPACITY

WITH ITS LARGE BODY AND SIZABLE STRAINING ELEMENT, THE YS58 PROVIDES EXCELLENT OPEN AREA RATIOS THAT ARE TYPICALLY TWO-AND-A-HALF TIMES LARGER THAN THE CORRESPONDING PIPELINE.

♦ PRECISION MACHINED SEATS

PRECISION MACHINED SCREEN SEATS IN BOTH THE BODY AND CAP HELP TO ENSURE ACCURATE POSITIONING OF THE SCREEN DURING REASSEMBLY AFTER CLEANING. ALSO, THE MACHINED BODY SEATS ENABLE FINER FILTRATION BY PREVENTING DEBRIS BYPASS.

♦ SELF-CLEANING CAPABILITY

WITH A TAPPED NPT BLOW-OFF CONNECTION, THIS UNIT CAN BE FITTED WITH A BLOW-DOWN VALVE WHICH FACILITATES CLEANING OF THE STRAINING ELEMENT. PLEASE CONTACT FACTORY FOR MORE INFORMATION.

♦ EPOXY PAINTED

ALL UNITS ARE EPOXY PAINTED TO HELP RESIST RUST AND CORROSION. TITAN FCI ALSO OFFERS EPOXY COATING AS AN OPTION FOR THE YS58.

♦ POTABLE WATER/FDA APPROVED COATINGS AVAILABLE



IN ADDITION TO ITS LEAD FREE, CAST IRON BODY, TITAN CAN PROVIDE NSF/ANSI AND FDA APPROVED EPOXY COATINGS WHICH MAKE THIS PRODUCT SUITABLE FOR POTABLE WATER AND FOOD CONTACT APPLICATIONS. NUMEROUS OPTIONS ARE AVAILABLE. PLEASE CONTACT US FOR MORE DETAILS.

♦ OPTIONAL COVER DESIGNS

TITAN'S YS58 IS AVAILABLE WITH DIFFERENT COVER OPTIONS INCLUDING SWING, CLAMP, AND HINGE TYPE COVERS. PLEASE CONSULT FACTORY FOR MORE INFORMATION ON THESE OPTIONS.

TECHNICAL

PRESSURE/TEMPERATURE RATING
CI-ASTM A126 GR. B - CLASS 125
SIZES 2" ~ 12"

WOG (Non-shock): 200 PSI @ 150 °F

PRESSURE/TEMPERATURE RATING
CI-ASTM A126 GR. B - CLASS 125
SIZES 14" ~ 24"

WOG (Non-shock): 150 PSI @ 150 °F

• The above listed temperatures are theoretical and may vary during actual operating conditions.

APPLICATIONS

GENERAL APPLICATION: Y-STRAINERS ARE INSTALLED IN A PIPING SYSTEM TO REMOVE UNWANTED DEBRIS FROM THE PIPELINE, PROTECTING EXPENSIVE EQUIPMENT DOWNSTREAM SUCH AS PUMPS, METERS, SPRAY NOZZLES, COMPRESSORS, AND TURBINES. THEY CAN BE PLACED IN A HORIZONTAL OR VERTICAL PIPELINE AS LONG AS THE SCREEN IS IN A DOWNWARD POSITION. STRAINING IS ACCOMPLISHED VIA AN INTERNAL PERFORATED OR MESH LINED STRAINING ELEMENT, THE SIZE OF WHICH SHOULD BE DETERMINED BASED ON THE SIZE OF THE SMALLEST PARTICLE TO BE REMOVED.

SERVICING: THE STRAINING ELEMENT NEEDS REGULAR CLEANING TO PREVENT DEBRIS BUILD UP. IT IS NOT ADVISABLE TO ALLOW THE DIFFERENTIAL PRESSURE TO INCREASE BY 20 PSI. ALTHOUGH CLEANING NORMALLY REQUIRES THE REMOVAL OF THE STRAINING ELEMENT, INSTALLING AND USING A TITAN BLOW-OFF DRAIN VALVE CAN INCREASE THE TIME BETWEEN CLEANINGS.

The above data represents common market and service applications. No representation or guarantee, expressed or implied, is given due to the numerous variations of concentrations, temperatures and flow conditions that may occur during actual service.

TITAN FLOW CONTROL, INC.

YOUR PIPELINE TO THE FUTURE!

Tel: 910-735-0000 ♦ Fax: 910-738-3848 ♦ titan@titanfci.com ♦ www.titanfci.com
290 Corporate Drive ♦ PO Box 7408 ♦ Lumberton, NC 28358



TITAN FLOW CONTROL, Inc.

290 Corporate Drive
Lumberton, NC 28358
Tel: 910.735.0000

E-mail: titan@titanfci.com
Web: www.titanfci.com
Fax: 910.738.3848

"Y" (WYE) STRAINER
YS 58-CI - (Cast Iron)
Flanged Ends • Flat Face • Cast Iron

ANSI Class
125

BILL OF MATERIALS ⁽¹⁾

No.	PART	YS 58-CI
1	Body	Cast Iron A126 Gr. B
2	Cover	Cast Iron A126 Gr. B
3	Straining Element ⁽²⁾	Stainless Steel
4	Gasket ⁽²⁾	Non-Asbestos Gasket, Garlock 3000 or Equal
5	Cap Screws	Steel
6	NPT Plug (Blow-off)	Carbon Steel
7	NPT Plugs (Gauge Taps) ⁽³⁾	Carbon Steel

1. Bill of Materials represents standard materials. Equivalent or better materials may be substituted at the manufacturer's discretion.
2. Denotes recommended spare parts.
3. Gauge taps and NPT Plugs (Part #7) are standard only on sizes 2" through 20". See Dimensions and Performance Data for the standard NPT sizes.

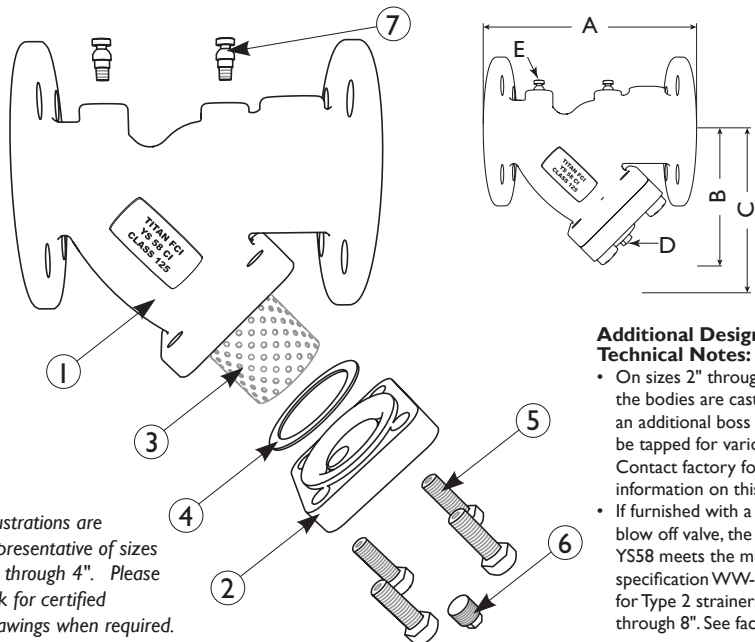

Illustrations are representative of sizes 2" through 4". Please ask for certified drawings when required.

Additional Design and Technical Notes:

- On sizes 2" through 6", the bodies are cast with an additional boss that can be tapped for various sizes. Contact factory for more information on this option.
- If furnished with a bronze blow off valve, the YS58 meets the military specification WW-S-2739 for Type 2 strainers, sizes 2" through 8". See factory.

DIMENSIONS AND PERFORMANCE DATA ⁽¹⁾

SIZE	in	2	2 1/2	3	4	5	6	8	10	12	14	16	18	20	24
	mm	50	65	80	100	125	150	200	250	300	350	400	450	500	600
A DIMENSION FACE TO FACE (FLAT FACE) ⁽²⁾	in	7.875	10.0	10.125	12.12	15.62	18.5	21.625	25.75	29.87	33.25	38.75	43.125	49.5	58.375
	mm	200	254	256	308	397	470	550	655	759	845	984	1095	1257	1483
B DIMENSION CENTER LINE TO BOTTOM	in	5.25	6.50	7.0	8.25	11.25	13.5	15.5	18.5	21.75	25.0	26.5	31.0	39.0	45.0
	mm	133	166	178	210	286	343	394	470	553	625	673	787	991	1143
C DIMENSION SCREEN REMOVAL	in	7.0	9.75	10.0	12.0	20.0	20.0	22.75	28.0	30.0	36.5	42.0	45.5	56.0	68.0
	mm	178	248	254	305	508	508	578	712	762	927	1067	1156	1422	1727
D NPT Plug BLOW-OFF	in	1/2	1	1	1 1/2	2	2	2	2	2	2	2	2	2	2
	mm	15	25	25	40	50	50	50	50	50	50	50	50	50	50
E NPT Plug GAUGETAPS	in	1/4	1/4	1/4	1/4	1/4	1/4	1/4	1/4	1/4	1/4	1/4	1/4	1/4	n/a
	mm	8	8	8	8	8	8	8	8	8	8	8	8	8	n/a
APPROXIMATE ASSEMBLED WEIGHT	lb	20.0	33.0	34.0	60.0	105.0	130.0	236.0	358.0	560.0	818.0	1145.0	1740.0	1888.0	3000.0
	kg	9.1	15.0	15.4	27.2	47.6	59.0	107.1	162.4	254.0	371.0	519.4	789.3	856.4	1360.8
Flow Coefficient	C _v	70	110	160	260	400	570	950	1600	2200	3300	4900	6100	8000	11000

1. Dimensions and weights are for reference only. When required, request certified drawings.
2. Face to face values have a tolerance of ±0.06 in (±2.0 mm) for sizes 10" and lower and a tolerance of ±0.12 in (±3.0 mm) for sizes 12" and larger.

PRESSURE - TEMPERATURE RATINGS ⁽¹⁾

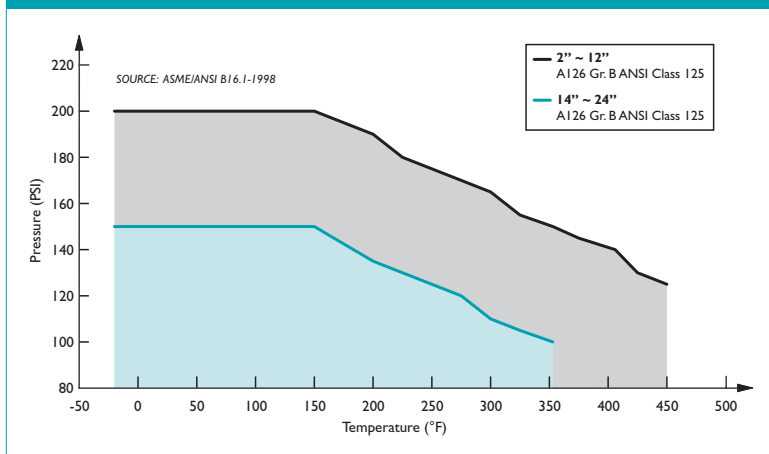

1. This chart displays the pressure-temperature ratings for the valve's body per ASME B16.1-1998.

Titan FCI makes every effort to ensure the information presented on our literature accurately reflects exact product specifications. However, as product changes occur, there may be short-term differences between actual product specifications and the information contained within our literature. Titan FCI reserves the right to make design and specification changes to improve our products without prior notification. When required, request certified drawings.

PRESSURE - TEMPERATURE RATING

A126 Gr. B	2" ~ 12"	14" ~ 24"
WOG (Non-shock):	200 PSI @ 150 °F	150 PSI @ 150 °F
Saturated Steam:	125 PSI @ 353°F	100 PSI @ 353°F
Max Liquid:	125 PSI @ 450 °F	100 PSI @ 353 °F

STANDARD SCREEN SELECTIONS

Size	Liquid	Open Area	Steam	Open Area
2" ~ 4"	1/16 (.0625)	41%	3/64 (.045)	36%
5" ~ 8"	1/8 (.125)	40%	3/64 (.045)	36%
10" ~ 16" ⁽¹⁾	1/8 (.125)	40%	30 Mesh Lined	44.8%

1. Please consult factory for screen selections on 18" and larger YS 58-CI models.

REFERENCED STANDARDS & CODES

CODE	DESCRIPTION
ASME/ANSI B16.1	Cast Iron Pipe Flanges and Flanged Fittings

TITAN

TITAN FLOW CONTROL, INC.

"Y" (WYE) STRAINER ♦ ANSI CLASS 250**CAST IRON ♦ FLANGED ENDS, RAISED FACE****MODELS: YS 59-CI****(CAST IRON)****FEATURES****SIZE RANGE: 2" ~ 12"**

LARGER SIZES AVAILABLE

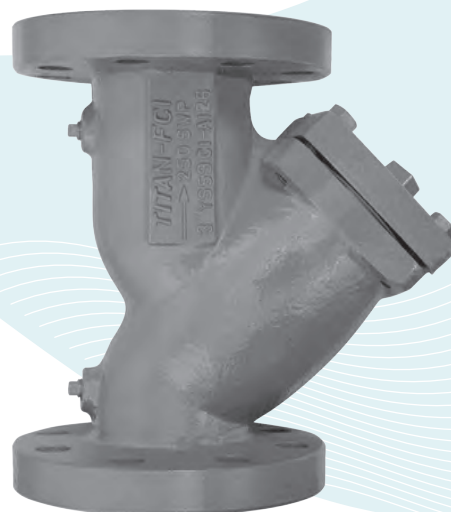

◇ **LARGE STRAINING CAPACITY**

WITH ITS LARGE BODY AND SIZABLE STRAINING ELEMENT, THE YS59 PROVIDES EXCELLENT OPEN AREA RATIOS THAT ARE TYPICALLY TWO-AND-A-HALF TIMES LARGER THAN THE CORRESPONDING PIPELINE.

◇ **PRECISION MACHINED SEATS**

PRECISION MACHINED SCREEN SEATS IN BOTH THE BODY AND CAP HELP TO ENSURE ACCURATE POSITIONING OF THE SCREEN DURING REASSEMBLY AFTER CLEANING. ALSO, THE MACHINED BODY SEATS ENABLE FINER FILTRATION BY PREVENTING DEBRIS BYPASS.

◇ **SELF-CLEANING CAPABILITY**

WITH A TAPPED NPT BLOW-OFF CONNECTION, THIS UNIT CAN BE FITTED WITH A BLOW-DOWN VALVE WHICH FACILITATES CLEANING OF THE STRAINING ELEMENT. PLEASE CONTACT FACTORY FOR MORE INFORMATION.

◇ **EPOXY PAINTED**

ALL UNITS ARE EPOXY PAINTED TO HELP RESIST RUST AND CORROSION. TITAN FCI ALSO OFFERS EPOXY COATING AS AN OPTION FOR THE YS59.

◇ **POTABLE WATER/FDA APPROVED COATINGS AVAILABLE**



IN ADDITION TO ITS LEAD FREE, CAST IRON BODY, TITAN CAN PROVIDE NSF/ANSI AND FDA APPROVED EPOXY COATINGS WHICH MAKE THIS PRODUCT SUITABLE FOR POTABLE WATER AND FOOD CONTACT APPLICATIONS. NUMEROUS OPTIONS ARE AVAILABLE. PLEASE CONTACT US FOR MORE DETAILS.

◇ **OPTIONAL COVER DESIGNS**

TITAN'S YS59 IS AVAILABLE WITH DIFFERENT COVER OPTIONS INCLUDING SWING, CLAMP, AND HINGE TYPE COVERS. PLEASE CONSULT FACTORY FOR MORE INFORMATION ON THESE OPTIONS.

TECHNICAL

PRESSURE/ TEMPERATURE RATING
CI-ASTM A126 GR. B - CLASS 250
SIZES 2" ~ 12"

WOG (Non-shock): 500 PSI @ 150 °F

PRESSURE/ TEMPERATURE RATING
CI-ASTM A126 GR. B - CLASS 250
SIZES 14" ~ 24"

WOG (Non-shock): 300 PSI @ 150 °F

• The above listed temperatures are theoretical and may vary during actual operating conditions.

APPLICATIONS

GENERAL APPLICATION: Y-STRAINERS ARE INSTALLED IN A PIPING SYSTEM TO REMOVE UNWANTED DEBRIS FROM THE PIPELINE, PROTECTING EXPENSIVE EQUIPMENT DOWNSTREAM SUCH AS PUMPS, METERS, SPRAY NOZZLES, COMPRESSORS, AND TURBINES. THEY CAN BE PLACED IN A HORIZONTAL OR VERTICAL PIPELINE AS LONG AS THE SCREEN IS IN A DOWNWARD POSITION. STRAINING IS ACCOMPLISHED VIA AN INTERNAL PERFORATED OR MESH LINED STRAINING ELEMENT, THE SIZE OF WHICH SHOULD BE DETERMINED BASED ON THE SIZE OF THE SMALLEST PARTICLE TO BE REMOVED.

SERVICING: THE STRAINING ELEMENT NEEDS REGULAR CLEANING TO PREVENT DEBRIS BUILD UP. IT IS NOT ADVISABLE TO ALLOW THE DIFFERENTIAL PRESSURE TO INCREASE BY 20 PSI. ALTHOUGH CLEANING NORMALLY REQUIRES THE REMOVAL OF THE STRAINING ELEMENT, INSTALLING AND USING A TITAN BLOW-OFF DRAIN VALVE CAN INCREASE THE TIME BETWEEN CLEANINGS.

The above data represents common market and service applications. No representation or guarantee, expressed or implied, is given due to the numerous variations of concentrations, temperatures and flow conditions that may occur during actual service.

TITAN FLOW CONTROL, INC.

YOUR PIPELINE TO THE FUTURE!

Tel: 910-735-0000 ♦ Fax: 910-738-3848 ♦ titan@titanfci.com ♦ www.titanfci.com
290 Corporate Drive ♦ PO Box 7408 ♦ Lumberton, NC 28358



TITAN FLOW CONTROL, Inc.

290 Corporate Drive
Lumberton, NC 28358
Tel: 910.735.0000

E-mail: titan@titanfci.com
Web: www.titanfci.com
Fax: 910.738.3848

"Y" (WYE) STRAINER
YS 59-CI - (Cast Iron)
Flanged Ends • Raised Face • Cast Iron

ANSI Class
250

BILL OF MATERIALS ⁽¹⁾

No.	PART	YS 59-CI
1	Body ⁽²⁾	Cast Iron A126 Gr. B
2	Cover	Cast Iron A126 Gr. B
3	Straining Element ⁽³⁾	Stainless Steel
4	Gasket ^{(3) (4)}	Non-Asbestos Gasket, Garlock 3000 or Equal
5	Cap Screws	Steel
6	NPT Plug (Blow-off)	Carbon Steel
7	NPT Plugs (Gauge Taps) ⁽³⁾	Carbon Steel

1. Bill of Materials represents standard materials. Equivalent or better materials may be substituted at the manufacturer's discretion.
2. Cast Iron bodies are epoxy painted.
3. Denotes recommended spare parts.
4. A wide range of gasket materials are available. Contact factory for more information.

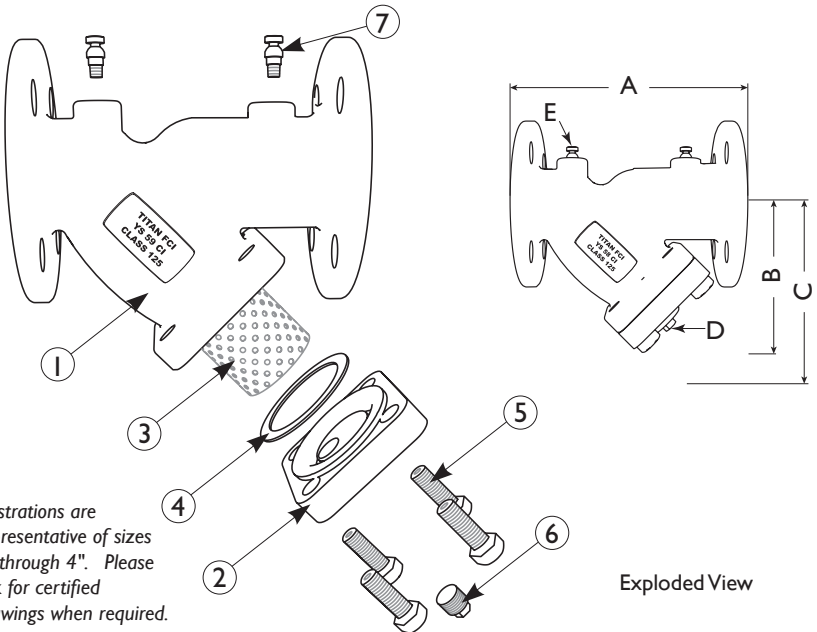

DIMENSIONS AND PERFORMANCE DATA ⁽¹⁾

SIZE ⁽²⁾	in	2	2 1/2	3	4	5	6	8	10	12
	mm	50	65	80	100	125	150	200	250	300
A DIMENSION FACE TO FACE (RAISED FACE) ⁽³⁾	in	9.62	10.62	12.00	14.50	16.62	19.25	23.37	27.37	32.00
	mm	244	270	305	369	423	489	594	696	813
B DIMENSION CENTER LINE TO BOTTOM	in	5.5	6.5	7.5	8.75	11.5	14.0	16.75	19.00	22.00
	mm	140	165	191	222	292	356	425	483	559
C DIMENSION SCREEN REMOVAL	in	9.00	11.00	12.50	15.00	17.00	20.00	24.12	28.50	33.00
	mm	229	280	318	381	432	508	613	724	839
D NPT Plug BLOW-OFF	in	1/2	1	1	1 1/2	2	2	2	2	2
	mm	15	25	25	40	50	50	50	50	50
E NPT Plug GAUGE TAPS	in	1/4	1/4	1/4	1/4	1/4	1/4	1/4	1/4	1/4
	mm	8	8	8	8	8	8	8	8	8
APPROXIMATE ASSEMBLED WEIGHT	lb	25.5	45.0	60.0	94.0	150.0	206.0	338.0	528.0	768.0
	kg	11.6	20.4	27.2	42.6	68.0	93.3	153.3	239.5	348.4
Flow Coefficient	C _v	70	110	160	260	400	570	950	1600	2200

1. Dimensions and weights are for reference only. When required, request certified drawings.
2. Larger sizes are available. Please consult factory for these sizes and dimensions.
3. Face to face values have a tolerance of ±0.06 in (±2.0 mm) for sizes 10" and lower and a tolerance of ±0.12 in (±3.0 mm) for sizes 12" and larger.

PRESSURE - TEMPERATURE RATINGS ⁽¹⁾

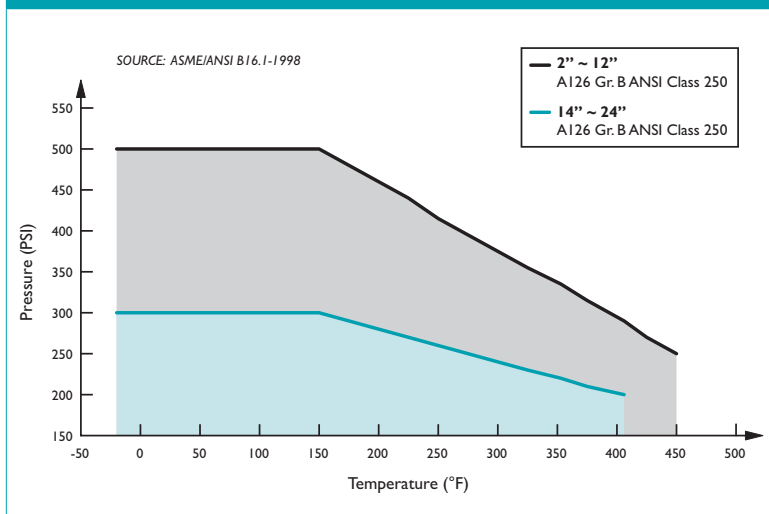

1. This chart displays the pressure-temperature ratings for the valve's body per ASME B16.1-1998.

PRESSURE - TEMPERATURE RATING

A126 Gr. B	2" ~ 12"	14" ~ 24"
WOG (Non-shock):	500 PSI @ 150 °F	300 PSI @ 150 °F

STANDARD SCREEN SELECTIONS

Size	Liquid	Open Area	Steam	Open Area
2" ~ 4"	1/16 (.0625)	41%	3/64 (.045)	36%
5" ~ 8"	1/8 (.125)	40%	3/64 (.045)	36%
10" ~ 14" ⁽¹⁾	1/8 (.125)	40%	30 Mesh Lined	44.8%

1. Please consult factory for screen selections on 16" and larger YS 59-CI models.

REFERENCED STANDARDS & CODES

CODE	DESCRIPTION
ASME/ANSI B16.1	Cast Iron Pipe Flanges and Flanged Fittings

Titan FCI makes every effort to ensure the information presented on our literature accurately reflects exact product specifications. However, as product changes occur, there may be short-term differences between actual product specifications and the information contained within our literature. Titan FCI reserves the right to make design and specification changes to improve our products without prior notification. When required, request certified drawings.



"Y" (WYE) STRAINER ❖ **THREADED ENDS**
ALUMINUM BRONZE ❖ **ANSI CLASS 250** ❖ **LEAD FREE (1)**

Meets **LEAD-FREE⁽¹⁾** requirements!

MODELS: YS 52-AB
(ALUMINUM BRONZE)

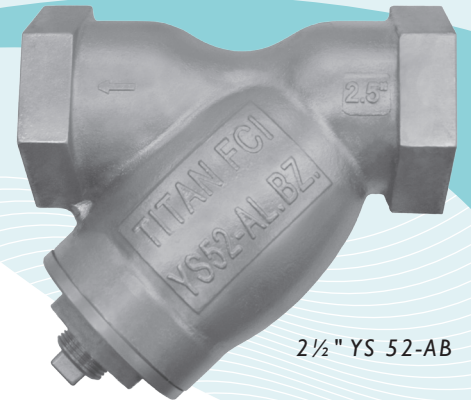

2 1/2" YS 52-AB

FEATURES

SIZE RANGE : 1/4" ~ 3"

❖ **ASTM B148 BODY MATERIAL**

ALUMINUM BRONZE IS STRONGER AND LESS LIKELY TO CORRODE THAN OTHER BRONZE ALLOYS, MAKING THEM A PREFERRED CHOICE FOR SEA WATER AND OTHER APPLICATIONS WHERE CORROSION IS A CONCERN. BECAUSE OF ITS COPPER CONTENT, MARINE ORGANISMS CANNOT COLONIZE ON THE MATERIAL. ADDITIONALLY, TITAN'S YS52-AB IS USED FOR POTABLE WATER APPLICATIONS AS IT MEETS LEAD FREE STATUTES REQUIRING THAT THE LEAD CONTENT IN THE WETTED SURFACES IS 0.25% OR LESS AS DETERMINED BY A WEIGHTED AVERAGE.

❖ **LARGE STRAINING CAPACITY**

WITH ITS LARGE BODY AND SIZABLE STRAINING ELEMENT, THE YS52 PROVIDES EXCELLENT OPEN AREA RATIOS THAT ARE TYPICALLY TWO-AND-A-HALF TIMES LARGER THAN THE CORRESPONDING PIPELINE, MINIMIZING PRESSURE DROP ACROSS THE VALVE.

❖ **PRECISION MACHINED SEATS**

PRECISION MACHINED SCREEN SEATS IN BOTH THE BODY AND CAP HELP TO ENSURE ACCURATE POSITIONING OF THE SCREEN DURING REASSEMBLY AFTER CLEANING. ALSO, THE MACHINED BODY SEATS ENABLE FINER FILTRATION BY PREVENTING DEBRIS BYPASS.

❖ **SELF-CLEANING CAPABILITY**

WITH A TAPPED NPT BLOW-OFF CONNECTION, THIS UNIT CAN BE FITTED WITH A BLOW-DOWN VALVE WHICH FACILITATES CLEANING OF THE STRAINING ELEMENT. PLEASE CONTACT FACTORY FOR MORE INFORMATION.

TECHNICAL

PRESSURE/TEMPERATURE RATING ⁽²⁾
AB - ASTM B148 GR. 9D - CLASS 250
YS 52-AB (THREADED)

WOG (Non-shock): 400 PSI @ 150 °F

1. The YS 52-AB meets requirements for lead free use in potable water systems. The lead content in the wetted surfaces is 0.25% or less as determined by a weighted average. For more information on lead free requirements, contact Titan Flow Control, Inc.
2. The above listed temperatures are theoretical and may vary during actual operating conditions.

APPLICATIONS

GENERAL APPLICATION: Y-STRAINERS ARE INSTALLED IN A PIPING SYSTEM TO REMOVE UNWANTED DEBRIS FROM THE PIPELINE, PROTECTING EXPENSIVE EQUIPMENT DOWNSTREAM SUCH AS PUMPS, METERS, SPRAY NOZZLES, COMPRESSORS, AND TURBINES. THEY CAN BE PLACED IN A HORIZONTAL OR VERTICAL PIPELINE AS LONG AS THE SCREEN IS IN A DOWNWARD POSITION. STRAINING IS ACCOMPLISHED VIA AN INTERNAL PERFORATED OR MESH LINED STRAINING ELEMENT, THE SIZE OF WHICH SHOULD BE DETERMINED BASED ON THE SIZE OF THE SMALLEST PARTICLE TO BE REMOVED.

SERVICING: THE STRAINING ELEMENT NEEDS REGULAR CLEANING TO PREVENT DEBRIS BUILD UP. IT IS NOT ADVISABLE TO ALLOW THE DIFFERENTIAL PRESSURE TO INCREASE BY 20 PSI. ALTHOUGH CLEANING NORMALLY REQUIRES THE REMOVAL OF THE STRAINING ELEMENT, INSTALLING AND USING A TITAN BLOW-OFF DRAIN VALVE CAN INCREASE THE TIME BETWEEN CLEANINGS.

The above data represents common market and service applications. No representation or guarantee, expressed or implied, is given due to the numerous variations of concentrations, temperatures and flow conditions that may occur during actual service.

TITAN FLOW CONTROL, INC.
YOUR PIPELINE TO THE FUTURE!

Tel: 910-735-0000 ❖ Fax: 910-738-3848 ❖ titan@titanfci.com ❖ www.titanfci.com



TITAN FLOW CONTROL, Inc.
 290 Corporate Drive
 Lumberton, NC 28358
 Tel: 910.735.0000
 E-mail: titan@titanfci.com
 Web: www.titanfci.com
 Fax: 910.738.3848

"Y" (WYE) STRAINER
YS 52-AB - (Threaded)

ANSI Class
 250

Threaded Ends • ANSI Class 250 • Aluminum Bronze

BILL OF MATERIALS ⁽¹⁾

No.	PART	YS 52 - AB
1	Body	Aluminum Bronze ASTM B148 Gr. 9D
2	Cap	Aluminum Bronze ASTM B148 Gr. 9D
3	Straining Element ⁽²⁾	Stainless Steel
4	Gasket ⁽²⁾	Teflon
5	NPT Plug (Blow-off)	Stainless Steel ⁽³⁾

Illustrations are representative of YS 52-AB (Threaded-end connections). Please ask for certified drawings when required.

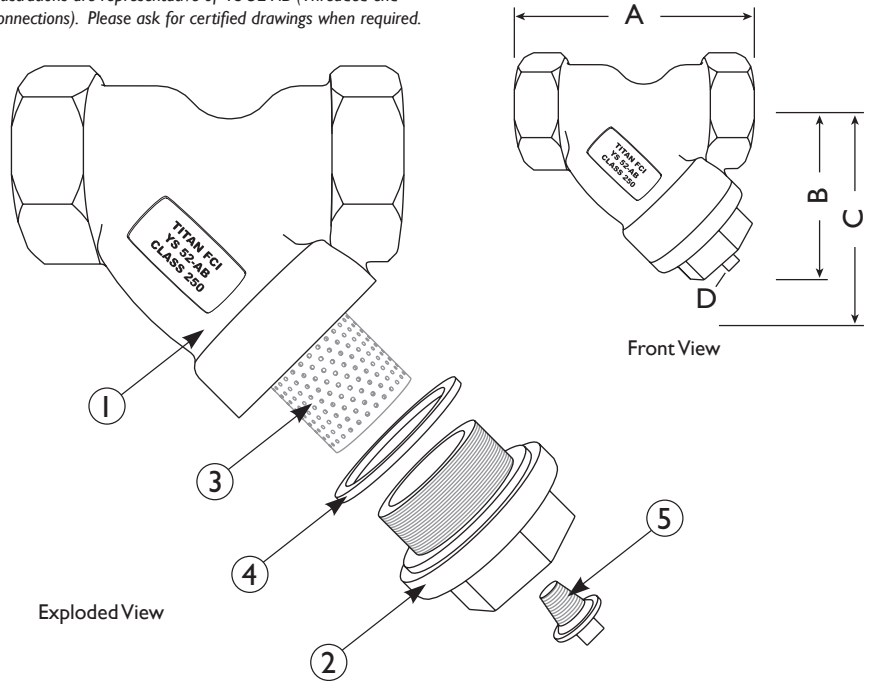

1. Bill of Materials represents standard materials. Equivalent or better materials may be substituted at the manufacturer's discretion.
2. Denotes recommended spare parts.
3. NPT Plug also available in other materials.

Body Material Application Notes:

- Aluminum Bronze (ASTM B148) is a preferred material for lead-free wye strainers, meeting requirements for potable water systems by containing 0.25% lead or less by average weight on all wetted parts.
- Aluminum Bronze is strong and corrosion resistant, meeting the needs of many various applications, such as seawater and marine.

DIMENSIONS AND PERFORMANCE DATA ⁽¹⁾

SIZE	in	1/4	3/8	1/2	3/4	1	1 1/4	1 1/2	2	2 1/2	3
	mm	8	10	15	20	25	32	40	50	65	80
A DIMENSION FACE TO FACE ⁽²⁾	in	2.75	2.75	2.75	3.00	3.75	4.43	5.00	5.68	9.00	9.00
	mm	70	70	70	76	95	113	127	144	229	229
B DIMENSION CENTER LINE TO BOTTOM	in	2.18	2.18	2.18	2.34	2.91	3.5	3.78	4.39	6.44	6.44
	mm	55	55	55	59	74	89	96	112	164	164
C DIMENSION SCREEN REMOVAL	in	4.00	4.00	4.00	4.25	4.75	5.25	6.00	7.00	10.00	10.00
	mm	102	102	102	108	121	133	152	178	254	254
D NPT Plug BLOW-OFF	in	1/4	1/4	1/4	1/4	3/8	3/4	3/4	1	1 1/4	1 1/4
	mm	8	8	8	8	10	20	20	25	32	32
APPROXIMATE ASSEMBLED WEIGHT	lb	0.5	0.5	0.5	1.0	1.8	2.5	4.0	5.6	15.9	15.9
	kg	0.2	0.2	0.2	0.5	0.8	1.1	1.8	2.5	7.2	7.2
Flow Coefficient	C _v	0.7	2	8	15	22	38	42	70	110	160

1. Dimensions and weights are for reference only. When required, request certified drawings.
2. Face to face values have a tolerance of ±0.06 in (±2.0 mm).

PRESSURE - TEMPERATURE RATINGS

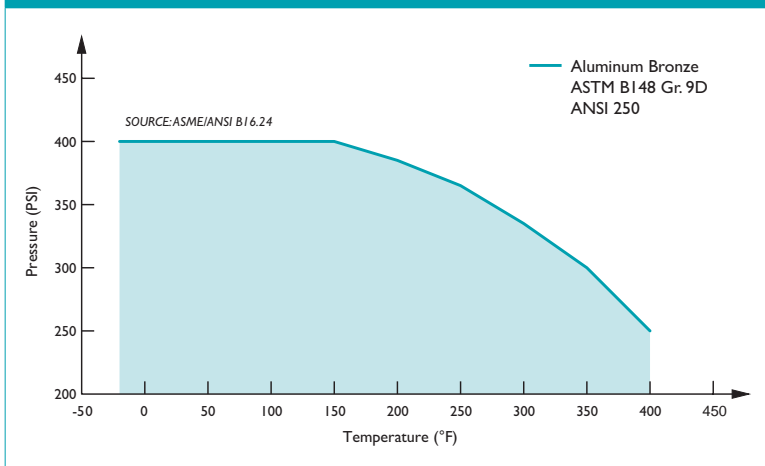

PRESSURE - TEMPERATURE RATING

ANSI Class 250

ASTM B148 Gr. 9D

WOG (Non-shock):

400 PSI @ 150 °F

STANDARD SCREEN SELECTIONS

Size	Liquid	Open Area	Steam	Open Area
1/4" ~ 2"	20 mesh	51.8%	30 mesh	44.8%
2 1/2" ~ 3"	1/16 (.0625)	41%	3/64 (.045)	36%

REFERENCED STANDARDS & CODES

CODE	DESCRIPTION
ASME/ANSI B16.15	Cast Bronze Threaded Fittings
ASME/ANSI B16.24	Cast Copper Alloy Pipe Flanges and Flanged Fittings

Titan FCI makes every effort to ensure the information presented on our literature accurately reflects exact product specifications. However, as product changes occur, there may be short-term differences between actual product specifications and the information contained within our literature. Titan FCI reserves the right to make design and specification changes to improve our products without prior notification. When required, request certified drawings.



TITAN FLOW CONTROL, INC.

"Y" (WYE) STRAINER ♦ FLANGED ENDS, FLAT FACED ALUMINUM BRONZE ♦ ANSI CLASS 150 ♦ LEAD FREE (1)

Meets LEAD-FREE⁽¹⁾ requirements!

MODELS: YS 54-AB
(ALUMINUM BRONZE)

New design includes
gauge taps as standard
on YS54-AB models



FEATURES

SIZE RANGE : 2" ~ 12"

♦ ASTM B148 BODY MATERIAL

ALUMINUM BRONZE IS STRONGER AND LESS LIKELY TO CORRODE THAN OTHER BRONZE ALLOYS, MAKING THEM A PREFERRED CHOICE FOR SEA WATER AND OTHER APPLICATIONS WHERE CORROSION IS A CONCERN. BECAUSE OF ITS COPPER CONTENT, MARINE ORGANISMS CANNOT COLONIZE ON THE MATERIAL. ADDITIONALLY, TITAN'S YS54-AB IS USED FOR POTABLE WATER APPLICATIONS AS IT MEETS LEAD FREE STATUTES REQUIRING THAT THE LEAD CONTENT IN THE WETTED SURFACES IS 0.25% OR LESS AS DETERMINED BY A WEIGHTED AVERAGE.

♦ NEW DESIGN WITH GAUGE TAPS

TITAN'S YS54 HAS CONVENIENT GAUGE TAPS FURNISHED WITH A PLUG ON BOTH THE INLET AND OUTLET SIDES OF SIZES 2" THROUGH 12". THESE TAPS ALLOW FOR EASY INSTALLATION OF PRESSURE GAUGES TO MONITOR DIFFERENTIAL PRESSURE AND DETERMINE WHEN SCREEN CLEANING IS NECESSARY.

♦ LARGE STRAINING CAPACITY

WITH ITS LARGE BODY AND SIZABLE STRAINING ELEMENT, THE YS54 PROVIDES EXCELLENT OPEN AREA RATIOS THAT ARE TYPICALLY TWO-AND-A-HALF TIMES LARGER THAN THE CORRESPONDING PIPELINE, MINIMIZING PRESSURE DROP ACROSS THE VALVE.

♦ PRECISION MACHINED SEATS

PRECISION MACHINED SCREEN SEATS IN BOTH THE BODY AND COVER HELP TO ENSURE ACCURATE POSITIONING OF THE SCREEN DURING REASSEMBLY AFTER CLEANING. ALSO, THE MACHINED BODY SEATS ENABLE FINER FILTRATION BY PREVENTING DEBRIS BYPASS.

♦ SELF-CLEANING CAPABILITY

WITH A TAPPED NPT BLOW-OFF CONNECTION, THIS UNIT CAN BE FITTED WITH A BLOW-DOWN VALVE WHICH FACILITATES CLEANING OF THE STRAINING ELEMENT. PLEASE CONTACT FACTORY FOR MORE INFORMATION.

TECHNICAL

PRESSURE/ TEMPERATURE RATING ⁽²⁾
AB - ASTM B148 GR. 9D - CLASS 150
YS 54-AB (FLANGED)

WOG (Non-shock): 225 PSI @ 150 °F

1. The YS 54-AB meets requirements for lead free use in potable water systems. The lead content in the wetted surfaces is 0.25% or less as determined by a weighted average. For more information on lead free requirements, contact Titan Flow Control, Inc.
2. The above listed temperatures are theoretical and may vary during actual operating conditions.

APPLICATIONS

GENERAL APPLICATION: Y-STRAINERS ARE INSTALLED IN A PIPING SYSTEM TO REMOVE UNWANTED DEBRIS FROM THE PIPELINE, PROTECTING EXPENSIVE EQUIPMENT DOWNSTREAM SUCH AS PUMPS, METERS, SPRAY NOZZLES, COMPRESSORS, AND TURBINES. THEY CAN BE PLACED IN A HORIZONTAL OR VERTICAL PIPELINE AS LONG AS THE SCREEN IS IN A DOWNWARD POSITION. STRAINING IS ACCOMPLISHED VIA AN INTERNAL PERFORATED OR MESH LINED STRAINING ELEMENT, THE SIZE OF WHICH SHOULD BE DETERMINED BASED ON THE SIZE OF THE SMALLEST PARTICLE TO BE REMOVED.

SERVICING: THE STRAINING ELEMENT NEEDS REGULAR CLEANING TO PREVENT DEBRIS BUILD UP. IT IS NOT ADVISABLE TO ALLOW THE DIFFERENTIAL PRESSURE TO INCREASE BY 20 PSI. ALTHOUGH CLEANING NORMALLY REQUIRES THE REMOVAL OF THE STRAINING ELEMENT, INSTALLING AND USING A TITAN BLOW-OFF DRAIN VALVE CAN INCREASE THE TIME BETWEEN CLEANINGS.

The above data represents common market and service applications. No representation or guarantee, expressed or implied, is given due to the numerous variations of concentrations, temperatures and flow conditions that may occur during actual service.

TITAN FLOW CONTROL, INC.
YOUR PIPELINE TO THE FUTURE!

Tel: 910-735-0000 ♦ Fax: 910-738-3848 ♦ titan@titanfci.com ♦ www.titanfci.com
290 Corporate Drive ♦ PO Box 7408 ♦ Lumberton, NC 28358



TITAN FLOW CONTROL, Inc.

290 Corporate Drive
Lumberton, NC 28358
Tel: 910.735.0000

E-mail: titan@titanfci.com
Web: www.titanfci.com
Fax: 910.738.3848

"Y" (WYE) STRAINER

YS 54-AB - (Flanged)

Flanged (Flat Faced) • ANSI Class 150 • Aluminum Bronze

ANSI Class
150

BILL OF MATERIALS ⁽¹⁾

No.	PART	YS 54-AB
1	Body	Aluminum Bronze ASTM B148 Gr. 9D
2	Cover	Aluminum Bronze ASTM B148 Gr. 9D
3	Straining Element ⁽²⁾	Stainless Steel
4	Gasket ⁽²⁾	Teflon
5	Cap Screw	Stainless Steel or Silicon Bronze
6	NPT Plug (Blow-off)	Aluminum Bronze ASTM B148 Gr. 9D
7	NPT Plug (Gauge Taps)	Stainless Steel ⁽³⁾

1. Bill of Materials represents standard materials. Equivalent or better materials may be substituted at the manufacturer's discretion.
2. Denotes recommended spare parts.
3. NPT Plug also available in other materials.

Body Material Application Notes:

- Aluminum Bronze (ASTM B148) is a preferred material for lead-free wye strainers, meeting requirements for potable water systems by containing 0.25% lead or less by average weight on all wetted parts.
- Aluminum Bronze is strong and corrosion resistant, meeting the needs of many various applications, such as seawater and marine.

Illustrations are representative of YS 54-AB (Flanged Ends, Flat Faced). Please ask for certified drawings when required.

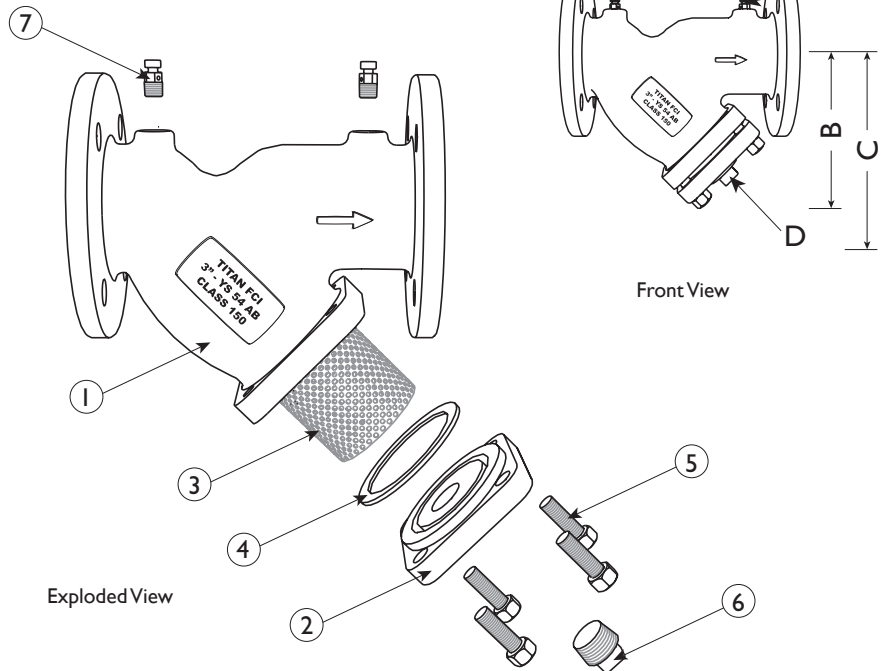

DIMENSIONS AND PERFORMANCE DATA ⁽¹⁾

SIZE	DIMENSIONS AND PERFORMANCE DATA ⁽¹⁾									
	in	2	2 1/2	3	4	5	6	8	10	12
A DIMENSION FACE TO FACE ⁽²⁾	mm	50	65	80	100	125	150	200	250	300
	in	7.75	9.75	10.06	12.12	C/F	18.30	21.37	26.00	C/F
B DIMENSION CENTER LINE TO BOTTOM	mm	197	248	256	308	C/F	465	543	660	C/F
	in	5.25	6.50	7.00	8.25	C/F	13.50	15.50	18.50	C/F
C DIMENSION SCREEN REMOVAL	mm	133	165	178	210	C/F	343	394	470	C/F
	in	7.00	9.75	10.00	12.00	C/F	20.00	22.75	28.00	C/F
D NPT Plug BLOW-OFF	mm	15	25	25	40	C/F	50	50	50	C/F
	in	1/2	1	1	1 1/2	C/F	2	2	2	C/F
E NPT Plug GAUGE TAPS	mm	8	8	8	8	C/F	8	8	8	C/F
	in	1/4	1/4	1/4	1/4	C/F	1/4	1/4	1/4	C/F
APPROXIMATE ASSEMBLED WEIGHT	lb	22.0	34.0	38.0	64.0	C/F	132.0	240.0	C/F	C/F
	kg	10.0	15.4	17.2	29.0	C/F	59.9	108.9	C/F	C/F
Flow Coefficient	C _v	70	110	160	260	C/F	570	950	1600	C/F

1. Dimensions and weights are for reference only. When required, request certified drawings.
2. Face to face dimension includes raised face. These values have a tolerance of ±0.06 in (±2.0 mm) for sizes 10" and lower and a tolerance of ±0.12 in (±3.0 mm) for sizes 12" and larger.

PRESSURE - TEMPERATURE RATINGS

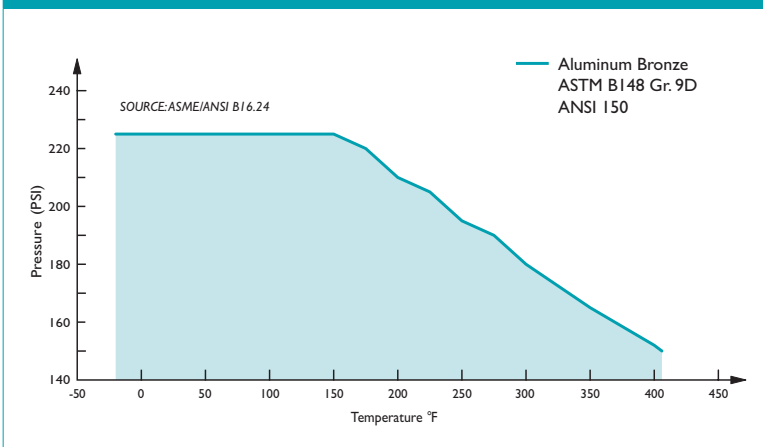

PRESSURE - TEMPERATURE RATING

ANSI Class 150 ASTM B148 Gr. 9D

WOG (Non-shock): 225 PSI @ 150 °F

STANDARD SCREEN SELECTIONS

Size	Liquid	Open Area	Steam	Open Area
2" ~ 4"	1/16 (.0625)	41%	1/32 (.033)	28%
5" ~ 8"	1/8 (.125)	40%	3/64 (.045)	36%
10" ~ 12"	1/8 (.125)	40%	30 Mesh Lined	44.8%

REFERENCED STANDARDS & CODES

CODE	DESCRIPTION
ASME/ANSI B16.24	Cast Copper Alloy Pipe Flanges and Flanged Fittings

Titan FCI makes every effort to ensure the information presented on our literature accurately reflects exact product specifications. However, as product changes occur, there may be short-term differences between actual product specifications and the information contained within our literature. Titan FCI reserves the right to make design and specification changes to improve our products without prior notification. When required, request certified drawings.



TITAN FLOW CONTROL, INC.

"Y" (WYE) STRAINER ♦ ANSI CLASS 125 CAST BRONZE ♦ THREADED AND SOLDER ENDS

MODELS: YS 55-BZ
(THREADED ENDS - BRONZE)
YS 56-BZ
(SOLDER ENDS - BRONZE)

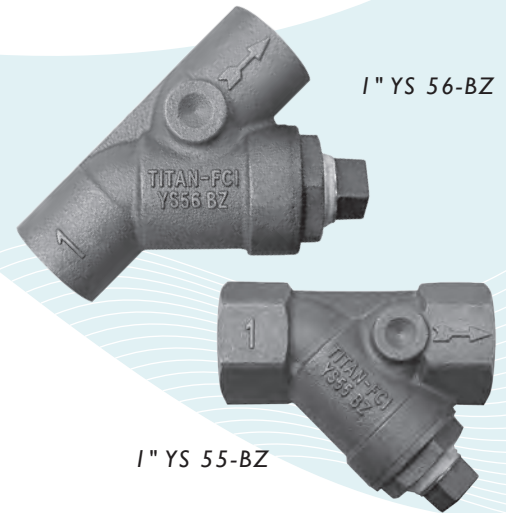

SIZE RANGE : 1/4" ~ 3"

FEATURES

- ♦ **LARGE STRAINING CAPACITY**
WITH ITS LARGE BODY AND SIZABLE STRAINING ELEMENT, THE YS55 AND YS56 PROVIDE EXCELLENT OPEN AREA RATIOS THAT ARE TYPICALLY TWO-AND-A-HALF TIMES LARGER THAN THE CORRESPONDING PIPELINE, MINIMIZING PRESSURE DROP ACROSS THE VALVE.
- ♦ **PRECISION MACHINED SEATS**
PRECISION MACHINED SCREEN SEATS IN BOTH THE BODY AND CAP HELP TO ENSURE ACCURATE POSITIONING OF THE SCREEN DURING REASSEMBLY AFTER CLEANING. ALSO, THE MACHINED BODY SEATS ENABLE FINER FILTRATION BY PREVENTING DEBRIS BYPASS.
- ♦ **SELF-CLEANING CAPABILITY**
WITH A TAPPED NPT BLOW-OFF CONNECTION, THIS UNIT CAN BE FITTED WITH A BLOW-DOWN VALVE WHICH FACILITATES CLEANING OF THE STRAINING ELEMENT. PLEASE CONTACT FACTORY FOR MORE INFORMATION.
- ♦ **THREADED CAP**
TITAN'S YS55 AND YS56 HAVE STRAIGHT THREADS TO PERMIT EASY CAP REMOVAL FOR CLEANING AND PROPER ALIGNMENT WHEN REASSEMBLING STRAINER.

TECHNICAL

PRESSURE/TEMPERATURE RATING ⁽¹⁾
BZ - C84400 - ASTM B584 - CLASS 125
YS 55-BZ (THREADED)

WOG (Non-shock): 200 PSI @ 150 °F

PRESSURE/TEMPERATURE RATING ⁽¹⁾
BZ - C84400 - ASTM B584 - CLASS 125
YS 56-BZ (SOLDER) ⁽²⁾

WOG (Non-shock):
400 PSI @ 100 °F (1/4" - 1 1/2")
315 PSI @ 100 °F (2" - 3")

1. The above listed temperatures are theoretical and may vary during actual operating conditions.
2. The internal working pressure rating for a solder joint strainer is dependent, not only on the strainer, but also on the composition of the solder used for the joint. The working pressure ratings shown for model YS 56-BZ (Solder) are representative of using an alloy Sb5 95-5 tin-antimony solder. For other solder joints, please consult factory.

APPLICATIONS

GENERAL APPLICATION: Y-STRAINERS ARE INSTALLED IN A PIPING SYSTEM TO REMOVE UNWANTED DEBRIS FROM THE PIPELINE, PROTECTING EXPENSIVE EQUIPMENT DOWNSTREAM SUCH AS PUMPS, METERS, SPRAY NOZZLES, COMPRESSORS, AND TURBINES. THEY CAN BE PLACED IN A HORIZONTAL OR VERTICAL PIPELINE AS LONG AS THE SCREEN IS IN A DOWNWARD POSITION. STRAINING IS ACCOMPLISHED VIA AN INTERNAL PERFORATED OR MESH LINED STRAINING ELEMENT, THE SIZE OF WHICH SHOULD BE DETERMINED BASED ON THE SIZE OF THE SMALLEST PARTICLE TO BE REMOVED.

SERVICING: THE STRAINING ELEMENT NEEDS REGULAR CLEANING TO PREVENT DEBRIS BUILD UP. IT IS NOT ADVISABLE TO ALLOW THE DIFFERENTIAL PRESSURE TO INCREASE BY 20 PSI. ALTHOUGH CLEANING NORMALLY REQUIRES THE REMOVAL OF THE STRAINING ELEMENT, INSTALLING AND USING A TITAN BLOW-OFF DRAIN VALVE CAN INCREASE THE TIME BETWEEN CLEANINGS.

The above data represents common market and service applications. No representation or guarantee, expressed or implied, is given due to the numerous variations of concentrations, temperatures and flow conditions that may occur during actual service.

TITAN FLOW CONTROL, INC.
YOUR PIPELINE TO THE FUTURE!

Tel: 910-735-0000 ♦ Fax: 910-738-3848 ♦ titan@titanfci.com ♦ www.titanfci.com
290 Corporate Drive ♦ PO Box 7408 ♦ Lumberton, NC 28358



TITAN FLOW CONTROL, Inc.

290 Corporate Drive
Lumberton, NC 28358
Tel: 910.735.0000

E-mail: titan@titanfci.com
Web: www.titanfci.com
Fax: 910.738.3848

"Y" (WYE) STRAINER
YS 55-BZ - (Threaded)
YS 56-BZ - (Solder)

ANSI Class
125

Threaded or Solder Ends • ANSI Class 125 • Bronze

BILL OF MATERIALS (1)

No.	PART	YS 55/56 - BZ
1	Body	Bronze (C84400) ASTM B584
2	Cap	Bronze (C84400) ASTM B584
3	Straining Element (2)	Stainless Steel
4	Gasket (2)	Teflon
5	NPT Plug (Blow-off)	Bronze (C84400) ASTM B584

1. Bill of Materials represents standard materials. Equivalent or better materials may be substituted at the manufacturer's discretion.
2. Denotes recommended spare parts.

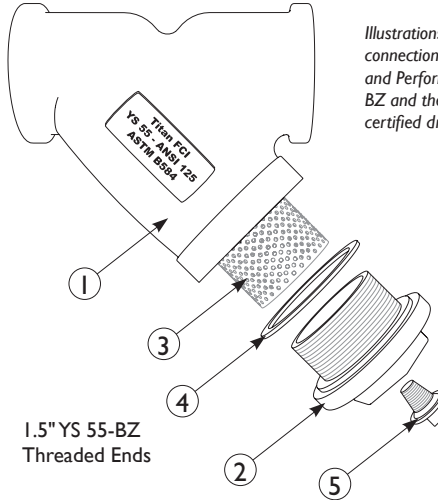

1.5" YS 55-BZ
Threaded Ends

Illustrations are representative of YS 55-BZ (Threaded-end connections) only. Materials, as listed to the left, and Dimensions and Performance Data, as listed below, include both the YS 55-BZ and the YS 56-BZ (Solder-end connections). Please ask for certified drawings when required.

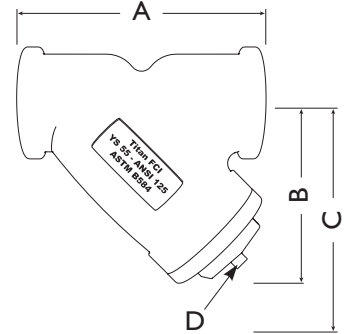

DIMENSIONS AND PERFORMANCE DATA (1)

SIZE	in	1/4	3/8	1/2	3/4	1	1 1/4	1 1/2	2	2 1/2	3
	mm	8	10	15	20	25	32	40	50	65	80
A DIMENSION FACE TO FACE (YS 55) (2)	in	C/F	2.38	2.80	3.18	3.70	4.41	4.93	5.91	C/F	10.60
	mm	C/F	61	71	81	94	112	125	150	C/F	269
A DIMENSION FACE TO FACE (YS 56) (2)	in	C/F	C/F	2.75	3.36	3.80	4.58	5.33	6.11	C/F	11.40
	mm	C/F	C/F	70	86	97	116	136	155	C/F	290
B DIMENSION CENTER LINE TO BOTTOM (YS 55)	in	C/F	1.39	1.60	1.86	2.13	2.50	2.92	3.60	C/F	5.50
	mm	C/F	36	41	48	54	64	74	92	C/F	140
B DIMENSION CENTER LINE TO BOTTOM (YS 56)	in	C/F	C/F	1.60	1.86	2.13	2.50	2.92	3.60	C/F	7.0
	mm	C/F	C/F	41	48	54	64	74	92	C/F	140
C DIMENSION SCREEN REMOVAL	in	C/F	3.75	4.0	4.25	4.75	6.0	7.0	8.0	C/F	10.0
	mm	C/F	95	102	108	121	152	178	203	C/F	254
D NPT Plug BLOW-OFF	in	C/F	1/4"	1/4"	1/4"	1/2"	1/2"	3/4"	1"	C/F	1"
	mm	C/F	8	8	8	15	15	20	25	C/F	25
ASSEMBLED WEIGHT YS 55 - THREADED (APPROXIMATE)	lb	C/F	0.35	0.45	0.85	1.30	2.00	2.65	4.30	C/F	12.90
	kg	C/F	0.16	0.21	0.39	0.6	0.91	1.21	1.95	C/F	5.85
ASSEMBLED WEIGHT YS 56 - SOLDER (APPROXIMATE)	lb	C/F	C/F	0.35	0.55	0.85	1.60	1.65	2.80	C/F	16.20
	kg	C/F	C/F	0.16	0.25	0.39	0.73	0.75	1.27	C/F	7.35
Flow Coefficient	C _v	0.7	2	8	15	22	38	42	70	110	160

1. Dimensions and weights are for reference only. When required, request certified drawings.
2. Face to face values have a tolerance of ±0.06 in (±2.0 mm).

PRESSURE - TEMPERATURE RATING - YS 55-BZ (Threaded)

(1/4" - 3")

WOG (Non-shock): 200 PSI @ 150 °F

PRESSURE - TEMPERATURE RATING - YS 56-BZ (Solder) (1)

(1/4" - 1 1/2") (2" - 3")

WOG (Non-shock): 400 PSI @ 100 °F 315 PSI @ 100 °F

STANDARD SCREEN SELECTIONS

Size	Liquid	Open Area	Steam	Open Area
1/4" ~ 2"	20 mesh	51.8%	30 mesh	44.8%
2 1/2" ~ 3"	1/16 (.0625)	41%	3/64 (.045)	36%

REFERENCED STANDARDS & CODES

CODE	DESCRIPTION
ASME/ANSI B16.15	Cast Bronze Threaded Fittings
ASME/ANSI B16.18	Cast Copper Alloy Solder Joint Pressure Fittings
ASME/ANSI B16.50	Copper Alloy Braze-Joint Pressure Fittings

PRESSURE - TEMPERATURE RATINGS (1)

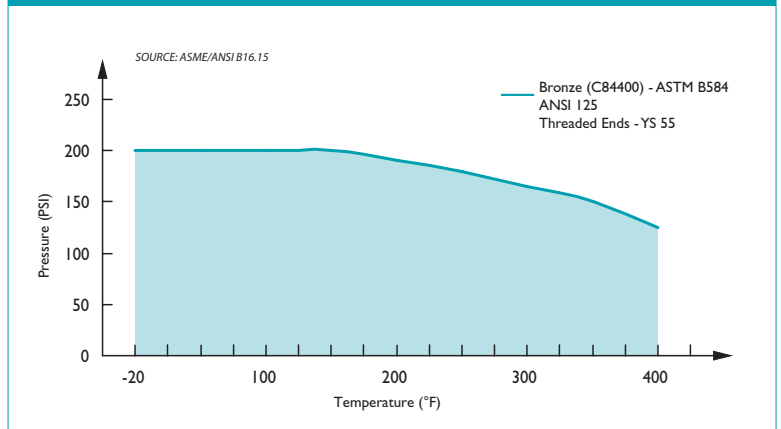

1. The pressure-temperature ratings given are ONLY for the YS 55-BZ (Threaded) per ASME B16.15. The internal working pressure rating for a solder joint strainer is dependent, not only on the strainer, but also on the composition of the solder used for the joint. The working pressure ratings shown for model YS 56-BZ (Solder) are representative of using an alloy Sb5 95-5 tin-antimony solder. For other solder joints, please consult factory.

Titan FCI makes every effort to ensure the information presented on our literature accurately reflects exact product specifications. However, as product changes occur, there may be short-term differences between actual product specifications and the information contained within our literature. Titan FCI reserves the right to make design and specification changes to improve our products without prior notification. When required, request certified drawings.



TITAN FLOW CONTROL, INC.

"Y" (WYE) STRAINER ♦ ANSI CLASS 125

ECO-BRASS ♦ THREADED AND SOLDER ENDS

MODELS: YS 55-EB
(THREADED ENDS - ECO-BRASS)

YS 56-EB
(SOLDER ENDS - ECO-BRASS)

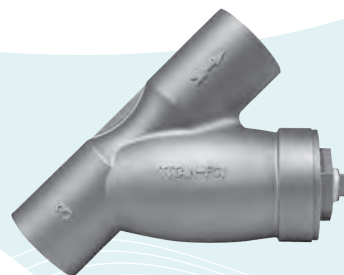

3" YS 56-EB

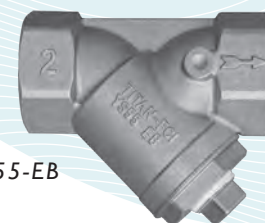

2" YS 55-EB

FEATURES

SIZE RANGE : 1/4" ~ 3"

♦ NEW ECO-BRASS® MATERIAL

ECO-BRASS® IS A LEAD-FREE, ENVIRONMENTALLY FRIENDLY BRASS MATERIAL. TITAN HAS UPGRADED OUR YS55 AND YS56 MODELS TO MEET THE DEMANDS OF THE MARKETPLACE THAT REQUIRE A LEAD-FREE BRASS ALTERNATIVE. ECO-BRASS® IS A HIGH-PERFORMANCE LEAD-FREE BRASS THAT PROVIDES EXCELLENT STRENGTH AND CORROSION RESISTANCE. ECO-BRASS® IS NSF COMPLIANT.

♦ LARGE STRAINING CAPACITY

WITH ITS LARGE BODY AND SIZABLE STRAINING ELEMENT, THE YS55 AND YS56 PROVIDE EXCELLENT OPEN AREA RATIOS THAT ARE TYPICALLY TWO-AND-A-HALF TIMES LARGER THAN THE CORRESPONDING PIPELINE, MINIMIZING PRESSURE DROP ACROSS THE VALVE.

♦ PRECISION MACHINED SEATS

PRECISION MACHINED SCREEN SEATS IN BOTH THE BODY AND CAP HELP TO ENSURE ACCURATE POSITIONING OF THE SCREEN DURING REASSEMBLY AFTER CLEANING. ALSO, THE MACHINED BODY SEATS ENABLE FINER FILTRATION BY PREVENTING DEBRIS BYPASS.

♦ SELF-CLEANING CAPABILITY

WITH A TAPPED NPT BLOW-OFF CONNECTION, THIS UNIT CAN BE FITTED WITH A BLOW-DOWN VALVE WHICH FACILITATES CLEANING OF THE STRAINING ELEMENT. PLEASE CONTACT FACTORY FOR MORE INFORMATION.

♦ THREADED CAP

TITAN'S YS55 AND YS56 HAVE STRAIGHT THREADS TO PERMIT EASY CAP REMOVAL FOR CLEANING AND PROPER ALIGNMENT WHEN REASSEMBLING STRAINER.

♦ POTABLE WATER/FDA APPLICATIONS



THIS PRODUCT IS SUITABLE FOR POTABLE WATER AND FOOD CONTACT APPLICATIONS. NUMEROUS OPTIONS ARE AVAILABLE. PLEASE CONTACT US FOR MORE INFORMATION REGARDING NSF APPLICATIONS.

TECHNICAL

PRESSURE/ TEMPERATURE RATING ⁽¹⁾

YS 55-EB (THREADED)

WOG (Non-shock): 200 PSI @ 150 °F

PRESSURE/ TEMPERATURE RATING ⁽¹⁾

YS 56-EB (SOLDER) ⁽²⁾

WOG (Non-shock):
400 PSI @ 100 °F (1/4" - 1 1/2")
315 PSI @ 100 °F (2" - 3")

1. The above listed temperatures are theoretical and may vary during actual operating conditions.
2. The internal working pressure rating for a solder joint strainer is dependent, not only on the strainer, but also on the composition of the solder used for the joint. The working pressure ratings shown for model YS 56-BZ (Solder) are representative of using an alloy Sb5 95-5 tin-antimony solder. For other solder joints, please consult factory.

APPLICATIONS

GENERAL APPLICATION: Y-STRAINERS ARE INSTALLED IN A PIPING SYSTEM TO REMOVE UNWANTED DEBRIS FROM THE PIPELINE, PROTECTING EXPENSIVE EQUIPMENT DOWNSTREAM SUCH AS PUMPS, METERS, SPRAY NOZZLES, COMPRESSORS, AND TURBINES. THEY CAN BE PLACED IN A HORIZONTAL OR VERTICAL PIPELINE AS LONG AS THE SCREEN IS IN A DOWNWARD POSITION. STRAINING IS ACCOMPLISHED VIA AN INTERNAL PERFORATED OR MESH LINED STRAINING ELEMENT, THE SIZE OF WHICH SHOULD BE DETERMINED BASED ON THE SIZE OF THE SMALLEST PARTICLE TO BE REMOVED.

SERVICING: THE STRAINING ELEMENT NEEDS REGULAR CLEANING TO PREVENT DEBRIS BUILD UP. IT IS NOT ADVISABLE TO ALLOW THE DIFFERENTIAL PRESSURE TO INCREASE BY 20 PSI. ALTHOUGH CLEANING NORMALLY REQUIRES THE REMOVAL OF THE STRAINING ELEMENT, INSTALLING AND USING A TITAN BLOW-OFF DRAIN VALVE CAN INCREASE THE TIME BETWEEN CLEANINGS.

The above data represents common market and service applications. No representation or guarantee, expressed or implied, is given due to the numerous variations of concentrations, temperatures and flow conditions that may occur during actual service.

TITAN FLOW CONTROL, INC.
YOUR PIPELINE TO THE FUTURE!

Tel: 910-735-0000 ♦ Fax: 910-738-3848 ♦ titan@titanfci.com ♦ www.titanfci.com
290 Corporate Drive ♦ PO Box 7408 ♦ Lumberton, NC 28358



TITAN FLOW CONTROL, Inc.

290 Corporate Drive
Lumberton, NC 28358
Tel: 910.735.0000

E-mail: titan@titanfci.com
Web: www.titanfci.com
Fax: 910.738.3848

"Y" (WYE) STRAINER
YS 55-EB - (Threaded)
YS 56-EB - (Solder)

ANSI Class
125

Threaded or Solder Ends • ANSI Class 125 • Silicone Brass

BILL OF MATERIALS (1)

No.	PART	YS 55/56 - EB
1	Body	Silicone Brass (C87850) ASTM A584
2	Cap	Silicone Brass (C87850) ASTM A584
3	Straining Element (2)	Stainless Steel
4	Gasket (2)	Teflon 1/4" - 2" Buna-N 2 1/2" - 3"
5	NPT Plug (Blow-off)	Silicone Brass (C87850) ASTM A584

1. Bill of Materials represents standard materials. Equivalent or better materials may be substituted at the manufacturer's discretion.
2. Denotes recommended spare parts.

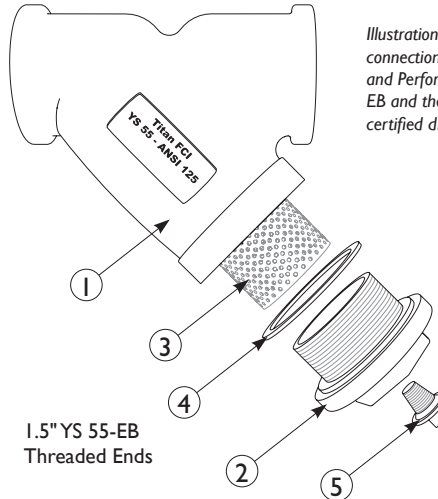

Illustrations are representative of YS 55-EB (Threaded-end connections) only. Materials, as listed to the left, and Dimensions and Performance Data, as listed below, include both the YS 55-EB and the YS 56-EB (Solder-end connections). Please ask for certified drawings when required.

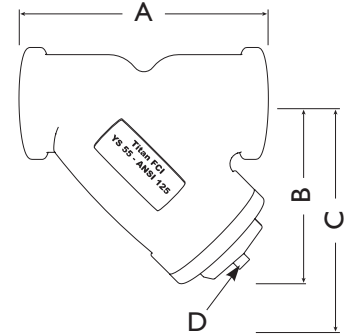

DIMENSIONS AND PERFORMANCE DATA (1)

SIZE	in	1/4	3/8	1/2	3/4	1	1 1/4	1 1/2	2	2 1/2	3
	mm	8	10	15	20	25	32	40	50	65	80
A DIMENSION FACE TO FACE (YS 55) (2)	in	C/F	2.38	2.80	3.18	3.70	4.41	4.93	5.91	C/F	10.60
	mm	C/F	61	71	81	94	112	125	150	C/F	269
A DIMENSION FACE TO FACE (YS 56) (2)	in	C/F	C/F	2.75	3.36	3.80	4.58	5.33	6.11	C/F	11.40
	mm	C/F	C/F	70	86	97	116	136	155	C/F	290
B DIMENSION CENTER LINE TO BOTTOM (YS 55)	in	C/F	1.39	1.60	1.86	2.13	2.50	2.92	3.60	C/F	5.50
	mm	C/F	36	41	48	54	64	74	92	C/F	140
B DIMENSION CENTER LINE TO BOTTOM (YS 56)	in	C/F	C/F	1.60	1.86	2.13	2.50	2.92	3.60	C/F	7.0
	mm	C/F	C/F	41	48	54	64	74	92	C/F	140
C DIMENSION SCREEN REMOVAL	in	C/F	3.75	4.0	4.25	4.75	6.0	7.0	8.0	C/F	10.0
	mm	C/F	95	102	108	121	152	178	203	C/F	254
D NPT Plug BLOW-OFF	in	C/F	1/4"	1/4"	1/4"	1/2"	1/2"	3/4"	1"	C/F	C/F
	mm	C/F	8	8	8	15	15	20	25	C/F	C/F
ASSEMBLED WEIGHT YS 55 - THREADED (APPROXIMATE)	lb	C/F	0.35	0.45	0.85	1.30	2.00	2.65	4.30	C/F	12.90
	kg	C/F	0.16	0.21	0.39	0.6	0.91	1.21	1.95	C/F	5.85
ASSEMBLED WEIGHT YS 56 - SOLDER (APPROXIMATE)	lb	C/F	C/F	0.35	0.55	0.85	1.60	1.65	2.80	C/F	16.20
	kg	C/F	C/F	0.16	0.25	0.39	0.73	0.75	1.27	C/F	7.35
Flow Coefficient	C _v	0.7	2	8	15	22	38	42	70	110	160

1. Dimensions and weights are for reference only. When required, request certified drawings.
2. Face to face values have a tolerance of ±0.06 in (±2.0 mm).

PRESSURE - TEMPERATURE RATING - YS 55-EB (Threaded)

(1/4" - 3")

WOG (Non-shock): 200 PSI @ 150 °F

PRESSURE - TEMPERATURE RATING - YS 56-EB (Solder) (1)

(1/4" - 1 1/2") (2" - 3")

WOG (Non-shock): 400 PSI @ 100 °F 315 PSI @ 100 °F

STANDARD SCREEN SELECTIONS

Size	Liquid	Open Area	Steam	Open Area
1/4" ~ 2"	20 mesh	51.8%	30 mesh	44.8%
2 1/2" ~ 3"	1/16 (.0625)	41%	3/64 (.045)	36%

REFERENCED STANDARDS & CODES

CODE	DESCRIPTION
ASME/ANSI B16.15	Cast Bronze Threaded Fittings
ASTM A584	Copper Alloy Sand Castings

PRESSURE - TEMPERATURE RATINGS (1)

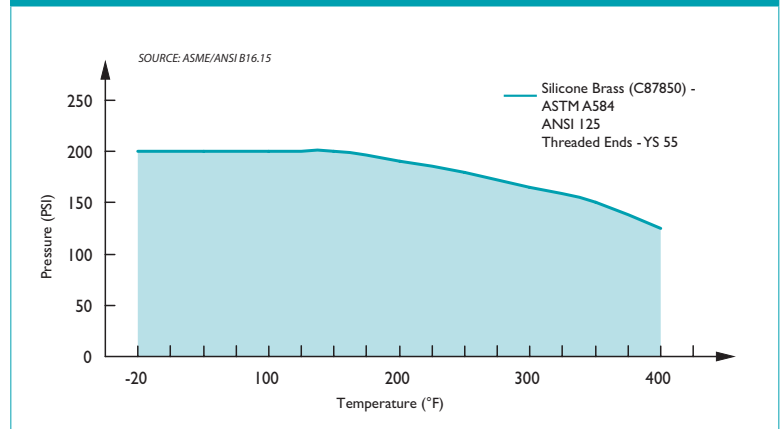

1. The pressure-temperature ratings given are ONLY for the YS 55-EB (Threaded) per ASME B16.15. The internal working pressure rating for a solder joint strainer is dependent, not only on the strainer, but also on the composition of the solder used for the joint. The working pressure ratings shown for model YS 56-BZ (Solder) are representative of using an alloy Sb5 95-5 tin-antimony solder. For other solder joints, please consult factory.

Titan FCI makes every effort to ensure the information presented on our literature accurately reflects exact product specifications. However, as product changes occur, there may be short-term differences between actual product specifications and the information contained within our literature. Titan FCI reserves the right to make design and specification changes to improve our products without prior notification. When required, request certified drawings.



"Y" (WYE) STRAINER ♦ STAINLESS STEEL

800 WOG ♦ THREADED AND SOCKET WELD ENDS

MODELS: YS 80T-SS

(THREADED ENDS - STAINLESS STEEL)

YS 80S-SS

(SOCKET WELD ENDS - STAINLESS STEEL)

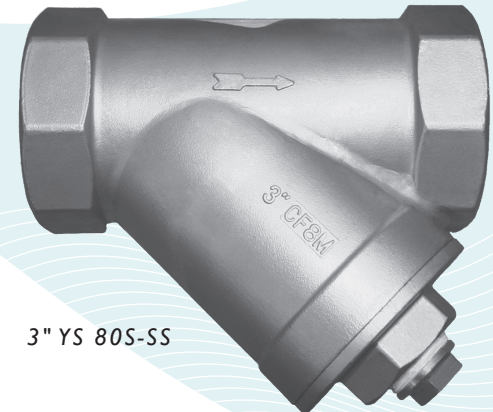

3" YS 80S-SS

SIZE RANGE : 1/4" ~ 4"

FEATURES

- ♦ **LARGE STRAINING CAPACITY**
WITH ITS LARGE BODY AND SIZABLE STRAINING ELEMENT, THE YS80T AND YS80S PROVIDE EXCELLENT OPEN AREA RATIOS THAT ARE TYPICALLY TWO-AND-A-HALF TIMES LARGER THAN THE CORRESPONDING PIPELINE, MINIMIZING PRESSURE DROP ACROSS THE VALVE.
- ♦ **PRECISION MACHINED SEATS**
PRECISION MACHINED SCREEN SEATS IN BOTH THE BODY AND CAP HELP TO ENSURE ACCURATE POSITIONING OF THE SCREEN DURING REASSEMBLY AFTER CLEANING. ALSO, THE MACHINED BODY SEATS ENABLE FINER FILTRATION BY PREVENTING DEBRIS BYPASS.
- ♦ **SELF-CLEANING CAPABILITY**
WITH A TAPPED NPT BLOW-OFF CONNECTION, THIS UNIT CAN BE FITTED WITH A BLOW-DOWN VALVE WHICH FACILITATES CLEANING OF THE STRAINING ELEMENT. PLEASE CONTACT FACTORY FOR MORE INFORMATION.
- ♦ **THREADED CAP**
TITAN'S YS80T AND YS80S HAVE STRAIGHT THREADS TO PERMIT EASY CAP REMOVAL FOR CLEANING AND PROPER ALIGNMENT WHEN REASSEMBLING STRAINER.

TECHNICAL

PRESSURE/TEMPERATURE RATING ⁽¹⁾
SS - ASTM A351 GR. CF8M
YS 80T-SS (THREADED)

WOG (Non-shock): 800 PSI @ 100 °F

PRESSURE/TEMPERATURE RATING ⁽¹⁾
SS - ASTM A351 GR. CF8M
YS 80S-SS (SOCKET WELD)

WOG (Non-shock): 800 PSI @ 100 °F

1. The above listed temperatures are theoretical and may vary during actual operating conditions.

APPLICATIONS

GENERAL APPLICATION: Y-STRAINERS ARE INSTALLED IN A PIPING SYSTEM TO REMOVE UNWANTED DEBRIS FROM THE PIPELINE, PROTECTING EXPENSIVE EQUIPMENT DOWNSTREAM SUCH AS PUMPS, METERS, SPRAY NOZZLES, COMPRESSORS, AND TURBINES. THEY CAN BE PLACED IN A HORIZONTAL OR VERTICAL PIPELINE AS LONG AS THE SCREEN IS IN A DOWNWARD POSITION. STRAINING IS ACCOMPLISHED VIA AN INTERNAL PERFORATED OR MESH LINED STRAINING ELEMENT, THE SIZE OF WHICH SHOULD BE DETERMINED BASED ON THE SIZE OF THE SMALLEST PARTICLE TO BE REMOVED.

SERVICING: THE STRAINING ELEMENT NEEDS REGULAR CLEANING TO PREVENT DEBRIS BUILD UP. IT IS NOT ADVISABLE TO ALLOW THE DIFFERENTIAL PRESSURE TO INCREASE BY 20 PSI. ALTHOUGH CLEANING NORMALLY REQUIRES THE REMOVAL OF THE STRAINING ELEMENT, INSTALLING AND USING A TITAN BLOW-OFF DRAIN VALVE CAN INCREASE THE TIME BETWEEN CLEANINGS.

The above data represents common market and service applications. No representation or guarantee, expressed or implied, is given due to the numerous variations of concentrations, temperatures and flow conditions that may occur during actual service.

TITAN FLOW CONTROL, INC.
YOUR PIPELINE TO THE FUTURE!

Tel: 910-735-0000 ♦ Fax: 910-738-3848 ♦ titan@titanfci.com ♦ www.titanfci.com
290 Corporate Drive ♦ PO Box 7408 ♦ Lumberton, NC 28358



TITAN FLOW CONTROL, Inc.

290 Corporate Drive
Lumberton, NC 28358
Tel: 910.735.0000

E-mail: titan@titanfci.com
Web: www.titanfci.com
Fax: 910.738.3848

"Y" (WYE) STRAINER
YS 80T-SS - (Threaded)
YS 80S-SS - (Socket Weld)

Threaded or Socket Weld • 800 WOG • Stainless Steel

Working Pressure:
800 PSI

BILL OF MATERIALS ⁽¹⁾

No.	PART	YS 80T - SS	YS 80S - SS
1	Body	ASTM A351 Gr. CF8M Type 316	ASTM A351 Gr. CF8M Type 316
2	Bonnet	ASTM A351 Gr. CF8M Type 316	ASTM A351 Gr. CF8M Type 316
3	Straining Element ⁽²⁾	Stainless Steel	Stainless Steel
4	Gasket ⁽²⁾	PTFE	PTFE
5	NPT Plug	Stainless Steel	Stainless Steel

1. Bill of Materials represents standard materials. Equivalent or better materials may be substituted at the manufacturer's discretion.
2. Denotes recommended spare parts.
3. Contact factory for more information.

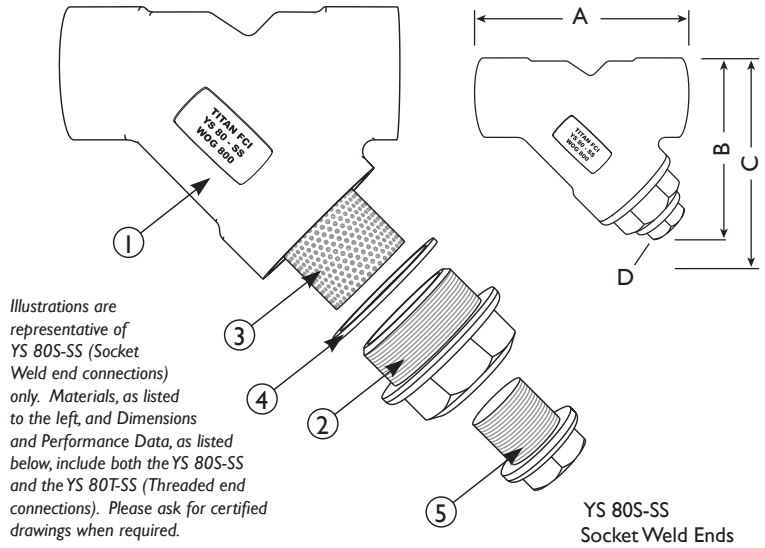

DIMENSIONS AND PERFORMANCE DATA ⁽¹⁾

SIZE	in	1/4	3/8	1/2	3/4	1	1 1/4	1 1/2	2	2 1/2	3	4
	mm	8	10	15	20	25	32	40	50	65	80	100
A DIMENSION FACE TO FACE (YS 80T) ⁽²⁾	in	2.55	2.55	2.55	3.14	3.54	4.13	4.72	5.50	6.69	7.67	9.44
	mm	65	65	65	80	90	105	120	140	170	195	240
A DIMENSION FACE TO FACE (YS 80S) ⁽²⁾	in	n/a	n/a	2.55	3.14	3.54	4.13	4.72	5.51	n/a	7.67	9.44
	mm	n/a	n/a	65	80	90	105	120	140	n/a	195	240
B DIMENSION CENTER LINE TO BOTTOM (YS 80T)	in	1.57	1.57	2.00	2.36	2.83	3.03	3.42	4.06	4.76	5.39	6.65
	mm	40	40	51	60	72	77	87	103	121	137	169
B DIMENSION CENTER LINE TO BOTTOM (YS 80S)	in	n/a	n/a	2.00	2.36	2.83	3.03	3.42	4.05	n/a	5.39	6.65
	mm	n/a	n/a	51	60	72	77	87	103	n/a	137	169
C DIMENSION SCREEN REMOVAL	in	2.00	2.00	2.50	3.25	3.75	4.25	4.75	5.50	6.50	8.00	C/F
	mm	51	51	64	83	95	108	120	140	165	203	C/F
D DIMENSION NPT PLUG (BLOW OFF)	in	1/4	1/4	1/4	3/8	3/8	3/4	3/4	1	1	1 1/4	C/F
	mm	8	8	8	10	10	20	20	25	25	32	C/F
APPROXIMATE ASSEMBLED WEIGHT	lb	0.5	0.5	0.5	1.0	1.5	2.0	2.5	4.0	6.5	9.0	C/F
	kg	0.2	0.2	0.2	0.5	0.7	0.9	1.1	1.8	2.9	4.1	C/F
Flow Coefficient	C _v	7	7	9.4	18	30	45	63	98	130	180	C/F

1. Dimensions and weights are for reference only. When required, request certified drawings.
2. Face to face values have a tolerance of ±0.06 in (±2.0 mm).

PRESSURE - TEMPERATURE RATINGS

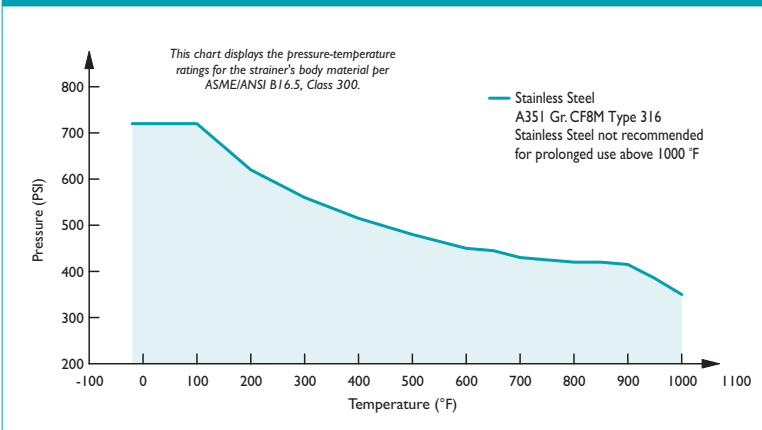

PRESSURE - TEMPERATURE RATING

Stainless Steel	YS 80T (Threaded)	YS 80S (Socket Weld)
WOG (Non-shock):	800 PSI @ 100°F	800 PSI @ 100°F

STANDARD SCREEN SELECTIONS

Size	Liquid	Open Area	Steam	Open Area
1/4" ~ 4"	1/16 (.0625)	41%	1/32 (.033)	28%

REFERENCED STANDARDS & CODES

CODE	DESCRIPTION
ASME/ANSI B16.34	Valves - Flanged, Threaded, and Welding End
ASME/ANSI B16.11	Forged Steel Fittings, Socket-Welding and Threaded
ASME/ANSI B1.20.1	National Pipe Thread Taper

Titan FCI makes every effort to ensure the information presented on our literature accurately reflects exact product specifications. However, as product changes occur, there may be short-term differences between actual product specifications and the information contained within our literature. Titan FCI reserves the right to make design and specification changes to improve our products without prior notification. When required, request certified drawings.



TITAN FLOW CONTROL, INC.

"Y" (WYE) STRAINER ♦ THREADED AND SOCKET WELD

ANSI CLASS 600 ♦ CARBON AND STAINLESS STEEL

MODELS: YS 81-CS
(CARBON STEEL - THREADED)

YS 82-CS
(CARBON STEEL - SOCKET WELD)

YS 81-SS
(STAINLESS STEEL - THREADED)

YS 82-SS
(STAINLESS STEEL - SOCKET WELD)

YS 81/82BC
(BOLTED COVER DESIGN)

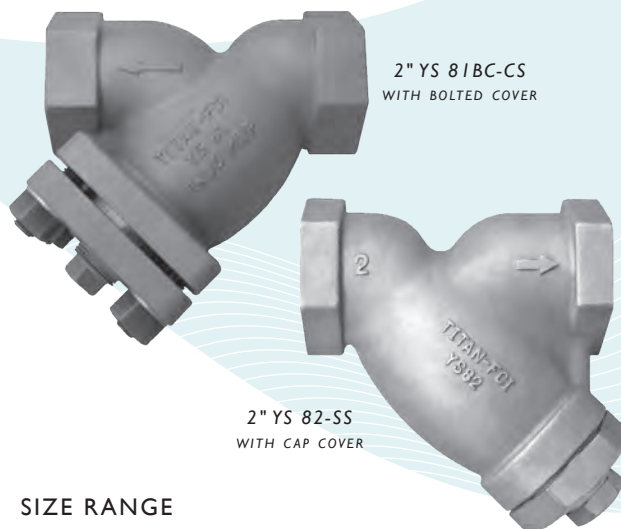
2" YS 81BC-CS
WITH BOLTED COVER2" YS 82-SS
WITH CAP COVER

SIZE RANGE
CAP COVER: ¼" ~ 2"
BOLTED COVER: 2" ~ 3"

FEATURES

- ♦ **BOLTED AND CAP COVER DESIGNS**
TITAN'S YS81BC AND YS82BC SIZES 2½" AND 3" HAVE A BOLTED COVER AS STANDARD. AN OPTIONAL BOLTED COVER IS ALSO AVAILABLE ON SIZE 2". CAP COVERS ARE STANDARD ON YS81 AND 82 SIZES ¼" - 1½".
- ♦ **RUGGED - HIGH QUALITY DESIGN**
THE YS81 AND YS82 ARE IDEAL FOR PETROCHEMICAL AND OTHER DEMANDING INDUSTRIAL APPLICATIONS THAT HAVE HIGHER PRESSURE AND TEMPERATURE REQUIREMENTS.
- ♦ **LARGE STRAINING CAPACITY**
WITH ITS LARGE BODY AND SIZABLE STRAINING ELEMENT, THE YS81 AND YS82 PROVIDE EXCELLENT OPEN AREA RATIOS THAT ARE TYPICALLY TWO-AND-A-HALF TIMES LARGER THAN THE CORRESPONDING PIPELINE.
- ♦ **PRECISION MACHINED SEATS**
PRECISION MACHINED SCREEN SEATS IN BOTH THE BODY AND CAP HELP TO ENSURE ACCURATE POSITIONING OF THE SCREEN DURING REASSEMBLY AFTER CLEANING. ALSO, THE MACHINED BODY SEATS ENABLE FINER FILTRATION BY PREVENTING DEBRIS BYPASS.
- ♦ **SELF-CLEANING CAPABILITY**
WITH THE OPTIONAL SOCKET WELD BLOW-OFF CONNECTION, THIS UNIT CAN BE FITTED WITH A BLOW-DOWN VALVE WHICH FACILITATES CLEANING OF THE STRAINING ELEMENT. PLEASE CONTACT FACTORY FOR MORE INFORMATION.
- ♦ **EPOXY PAINTED**
CARBON UNITS ARE EPOXY PAINTED TO HELP RESIST RUST AND CORROSION. TITAN FCI ALSO OFFERS EPOXY COATING. PLEASE CONTACT FACTORY FOR MORE INFORMATION.

TECHNICAL

PRESSURE/TEMPERATURE RATING
CS - ASTM A216 GR. WCB - CLASS 600

WOG (Non-shock): 1480 PSI @ 100 °F

PRESSURE/TEMPERATURE RATING
SS - ASTM A351 GR. CF8M - CLASS 600

WOG (Non-shock): 1440 PSI @ 100 °F

- The above listed temperatures are theoretical and may vary during actual operating conditions.
- Carbon Steel not recommended for prolonged use above 800 °F.
- Stainless Steel not recommended for prolonged use above 1000 °F.

APPLICATIONS

CARBON STEEL PROPERTIES: CARBON STEEL PERFORMS EXCEPTIONALLY WELL IN HIGH TEMPERATURES, UP TO 800°F IN CONTINUOUS SERVICE. IT PROVIDES HIGH RESISTANCE TO SHOCK, VIBRATION, PIPING STRAINS, AND FIRE AND FREEZING HAZARDS. CARBON STEEL STRAINERS ARE OFTEN USED IN THE OIL AND PETROCHEMICAL INDUSTRIES

STAINLESS STEEL PROPERTIES: STAINLESS STEEL IS COMMONLY SPECIFIED FOR HIGH TEMPERATURE SERVICE, UP TO 1000°F IN CONTINUOUS SERVICE. STAINLESS STEEL STRAINERS ARE COMMONLY FOUND IN THE CHEMICAL, FOOD, AND PHARMACEUTICAL INDUSTRIES.

The above data represents common market and service applications. No representation or guarantee, expressed or implied, is given due to the numerous variations of concentrations, temperatures and flow conditions that may occur during actual service.

TITAN FLOW CONTROL, INC.
YOUR PIPELINE TO THE FUTURE!

Tel: 910-735-0000 ♦ Fax: 910-738-3848 ♦ titan@titanfci.com ♦ www.titanfci.com
290 Corporate Drive ♦ PO Box 7408 ♦ Lumberton, NC 28358



TITAN FLOW CONTROL, Inc.
 290 Corporate Drive
 Lumberton, NC 28358
 Tel: 910.735.0000
 E-mail: titan@titanfci.com
 Web: www.titanfci.com
 Fax: 910.738.3848

WYE STRAINER

Threaded Ends	Socket Weld Ends
YS 81-CS (Carbon Steel)	YS 82-CS (Carbon Steel)
YS 81-SS (Stainless Steel)	YS 82-SS (Stainless Steel)

ANSI Class
600

BILL OF MATERIALS (1)

No.	PART	YS 81/82-CS (6)	YS 81/82-SS
1	Body (2)	Carbon Steel A216 Gr. WCB	Stainless Steel A351 Gr. CF8M
2	Cover/Cap (5)	Carbon Steel A216 Gr. WCB	Stainless Steel A351 Gr. CF8M
3	Straining Element (3)	Stainless Steel	Stainless Steel
4	Gasket (3)(4)	Stainless Steel Spiral Wound	Stainless Steel Spiral Wound
5	Studs (5) BC models only	Alloy Steel	Alloy Steel
6	Nuts (5) BC models only	Alloy Steel	Alloy Steel
7	Plug	Carbon Steel	Stainless Steel

Illustrations are representative of different YS81/82 models. Exploded view is shown with bolted cover; front view with cap. Contact factory for certified drawings of specific models when required.

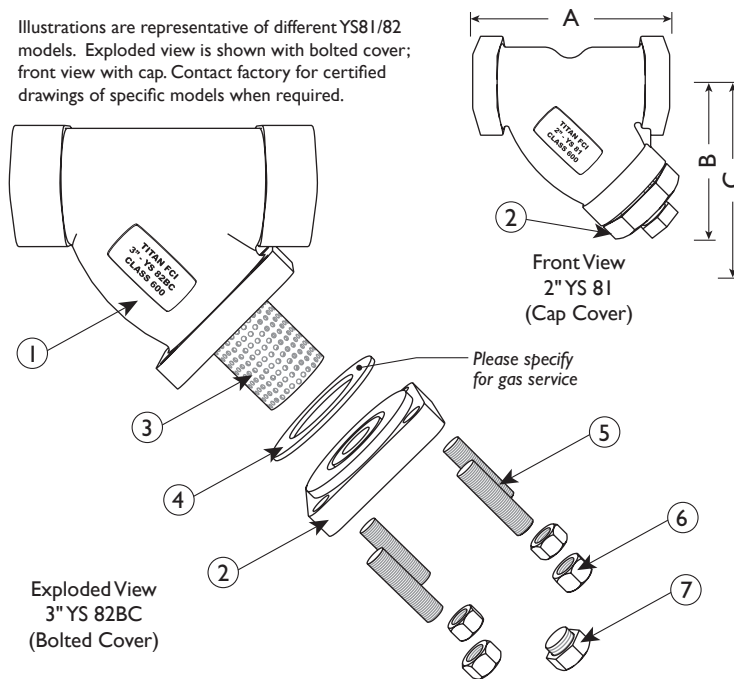

- Bill of Materials represents standard materials. Equivalent or better materials may be substituted at the manufacturer's discretion.
- Available in additional body materials, such as LCB, WC6, WC9, 316L, Alloy 20, and Monel.
- Denotes recommended spare parts.
- The cover gasket is encapsulated in a machined recessed seat. A wide range of gasket materials are available; contact factory.
- Only bolted cover designs (2 1/2", 3", and optional 2") have Parts 5 and 6 (Studs and Nuts). Threaded cap covers are standard on Sizes 1/4" through 1 1/2". Size 2" is available with either a bolted or cap cover.
- Carbon Steel bodies are epoxy painted.

DIMENSIONS AND PERFORMANCE DATA (1)

SIZE	in	1/4	3/8	1/2	3/4	1	1 1/4	1 1/2	2 (3)	2 1/2 (4)	3 (4)	
	mm	8	10	15	20	25	32	40	50	65	80	
A DIMENSION THREADED COVER	in	2.93	2.93	2.93	3.68	4.56	4.93	5.56	6.93	n/a	n/a	
	mm	75	75	75	94	116	126	142	177	n/a	n/a	
A DIMENSION BOLTED COVER	in	BOLTED COVER NOT AVAILABLE IN SIZES 1/4" - 1 1/2"								7.50	12.00	12.00
	mm	BOLTED COVER NOT AVAILABLE IN SIZES 1/4" - 1 1/2"								191	305	305
B DIMENSION CENTER LINE TO BOTTOM	in	2.37	2.37	2.37	2.81	3.68	4.12	4.75	6.00	10.50	10.50	
	mm	61	61	61	72	94	105	121	153	267	267	
C DIMENSION SCREEN REMOVAL	in	2.62	2.62	2.62	3.37	4.75	5.25	6.00	7.25	16.00	16.00	
	mm	67	67	67	86	121	134	153	184	407	407	
D NPT Plug BLOW-OFF	in	1/4	1/4	1/4	3/8	3/8	3/4	3/4	1	1 1/4	1 1/4	
	mm	8	8	8	10	10	20	20	25	32	32	
APPROXIMATE ASSEMBLED WEIGHT	lb	1.5	1.5	1.5	2.5	5.0	5.5	9.0	13.0	46.0	43.0	
	kg	0.7	0.7	0.7	1.1	2.3	2.5	4.1	5.9	20.9	19.5	
Flow Coefficient	C _v	0.7	2	8	15	22	38	42	70	110	160	

- Dimensions and weights are for reference only. When required, request certified drawings.
- Face to face values have a tolerance of ±0.06 in (±2.0 mm) for sizes 10" and lower.
- Size 2" is available in either a cap or bolted cover; please specify when ordering. Weight given is for model with cap cover.
- Sizes 2 1/2" and 3" have bolted covers.

PRESSURE - TEMPERATURE RATINGS

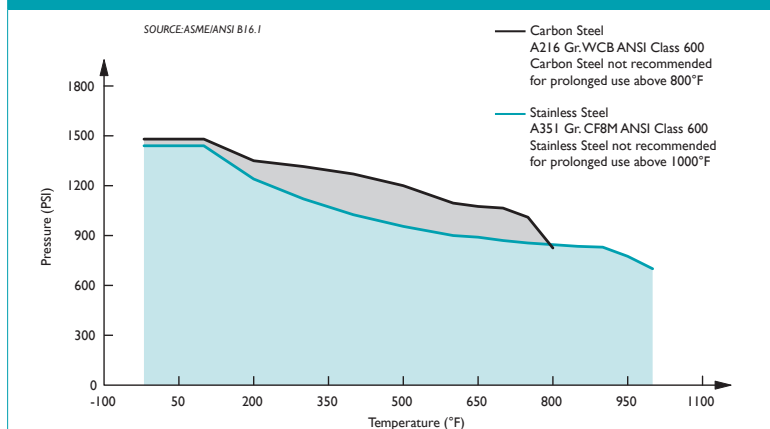

PRESSURE - TEMPERATURE RATING

Body Material	A216 Gr. WCB	A351 Gr. CF8M
WOG (Non-shock):	1480 PSI @ 100 °F	1440 PSI @ 100 °F

REFERENCED STANDARDS & CODES

CODE	DESCRIPTION
ANSI/ASME B1.20.1	National Pipe Thread Taper
ASME/ANSI B16.11	Forged Steel Fittings, Socket-Welding & Threaded
ASME/ANSI B16.34	Flanged, Threaded, and Welding End

STANDARD SCREEN SELECTIONS

Size	Liquid	Open Area	Steam	Open Area
1/2" ~ 3"	1/16 (.0625)	41%	1/32 (.033)	28%

Titan FCI makes every effort to ensure the information presented on our literature accurately reflects exact product specifications. However, as product changes occur, there may be short-term differences between actual product specifications and the information contained within our literature. Titan FCI reserves the right to make design and specification changes to improve our products without prior notification. When required, request certified drawings.



TITAN FLOW CONTROL, INC.

"Y" (WYE) STRAINER ♦ THREADED AND SOCKET WELD

ANSI CLASS 1500 ♦ CARBON AND STAINLESS STEEL

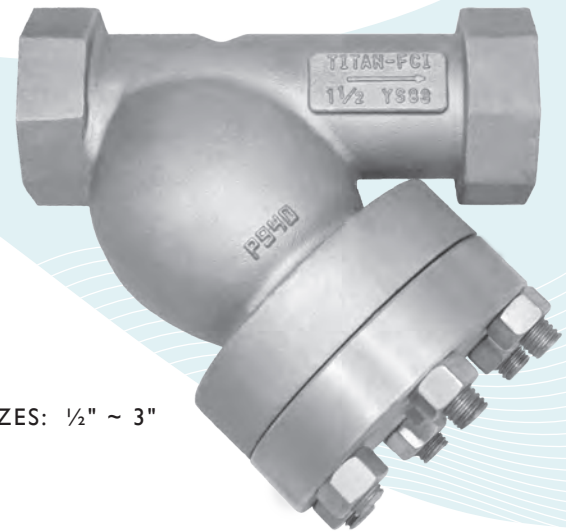

MODELS: YS 83-CS
(CARBON STEEL - THREADED)

YS 84-CS
(CARBON STEEL - SOCKET WELD)

YS 83-SS
(STAINLESS STEEL - THREADED)

YS 84-SS
(STAINLESS STEEL - SOCKET WELD)

SIZES: 1/2" ~ 3"

FEATURES

- ♦ **RUGGED - HIGH QUALITY DESIGN**
TITAN'S YS83 AND YS84 ARE IDEAL FOR PETROCHEMICAL AND OTHER DEMANDING INDUSTRIAL APPLICATIONS THAT HAVE HIGHER PRESSURE AND TEMPERATURE REQUIREMENTS. THEY ARE DUAL RATED FOR ANSI CLASS 600 AND 1500.
- ♦ **LARGE STRAINING CAPACITY**
WITH ITS LARGE BODY AND SIZABLE STRAINING ELEMENT, THE YS83 AND YS84 PROVIDE EXCELLENT OPEN AREA RATIOS THAT ARE TYPICALLY TWO-AND-A-HALF TIMES LARGER THAN THE CORRESPONDING PIPELINE.
- ♦ **PRECISION MACHINED SEATS**
PRECISION MACHINED SCREEN SEATS IN BOTH THE BODY AND CAP HELP TO ENSURE ACCURATE POSITIONING OF THE SCREEN DURING REASSEMBLY AFTER CLEANING. ALSO, THE MACHINED BODY SEATS ENABLE FINER FILTRATION BY PREVENTING DEBRIS BYPASS.
- ♦ **ENCAPSULATED "CG" STYLE GASKET**
THE "CG" STYLE COVER GASKET PROVIDES ADDITIONAL RADIAL STRENGTH TO PREVENT GASKET BLOWOUT. IT ALSO ACTS AS A COMPRESSION STOP.
- ♦ **SELF-CLEANING CAPABILITY**
WITH THE OPTIONAL SOCKET WELD BLOW-OFF CONNECTION, THIS UNIT CAN BE FITTED WITH A BLOW-DOWN VALVE WHICH FACILITATES CLEANING OF THE STRAINING ELEMENT. PLEASE CONTACT FACTORY FOR MORE INFORMATION.
- ♦ **EPOXY PAINTED**
CARBON UNITS ARE EPOXY PAINTED TO HELP RESIST RUST AND CORROSION. TITAN FCI ALSO OFFERS EPOXY COATING. PLEASE CONTACT FACTORY FOR MORE INFORMATION.

TECHNICAL

PRESSURE/TEMPERATURE RATING
CS - ASTM A216 GR. WCB - CLASS 1500

WOG (Non-shock): 3705 PSI @ 100 °F

PRESSURE/TEMPERATURE RATING
SS - ASTM A351 GR. CF8M - CLASS 1500

WOG (Non-shock): 3600 PSI @ 100 °F

- The above listed temperatures are theoretical and may vary during actual operating conditions.
- Carbon Steel not recommended for prolonged use above 800 °F.
- Stainless Steel not recommended for prolonged use above 1000 °F.

APPLICATIONS

CARBON STEEL PROPERTIES: CARBON STEEL PERFORMS EXCEPTIONALLY WELL IN HIGH TEMPERATURES, UP TO 800°F IN CONTINUOUS SERVICE. IT PROVIDES HIGH RESISTANCE TO SHOCK, VIBRATION, PIPING STRAINS, AND FIRE AND FREEZING HAZARDS. CARBON STEEL STRAINERS ARE OFTEN USED IN THE OIL AND PETROCHEMICAL INDUSTRIES

STAINLESS STEEL PROPERTIES: STAINLESS STEEL IS COMMONLY SPECIFIED FOR HIGH TEMPERATURE SERVICE, UP TO 1000°F IN CONTINUOUS SERVICE. STAINLESS STEEL STRAINERS ARE COMMONLY FOUND IN THE CHEMICAL, FOOD, AND PHARMACEUTICAL INDUSTRIES.

The above data represents common market and service applications. No representation or guarantee, expressed or implied, is given due to the numerous variations of concentrations, temperatures and flow conditions that may occur during actual service.

TITAN FLOW CONTROL, INC.
YOUR PIPELINE TO THE FUTURE!

Tel: 910-735-0000 ♦ Fax: 910-738-3848 ♦ titan@titanfci.com ♦ www.titanfci.com
290 Corporate Drive ♦ PO Box 7408 ♦ Lumberton, NC 28358



TITAN FLOW CONTROL, Inc.
 290 Corporate Drive
 Lumberton, NC 28358
 Tel: 910.735.0000
 E-mail: titan@titanfci.com
 Web: www.titanfci.com
 Fax: 910.738.3848

WYE STRAINER

Threaded Ends	Socket Weld Ends
YS 83-CS (Carbon Steel)	YS 84-CS (Carbon Steel)
YS 83-SS (Stainless Steel)	YS 84-SS (Stainless Steel)

ANSI Class
 1500

BILL OF MATERIALS (1)

No.	PART	YS 83/84-CS (2)	YS 83/84-SS
1	Body	Carbon Steel A216 Gr. WCB	Stainless Steel A351 Gr. CF8M
2	Cover	Carbon Steel A216 Gr. WCB	Stainless Steel A351 Gr. CF8M
3	Straining Element (2)	Stainless Steel	Stainless Steel
4	Gasket (2)	Stainless Steel CG Style	Stainless Steel CG Style
5	Studs	Alloy Steel	Alloy Steel
6	Nuts	Alloy Steel	Alloy Steel

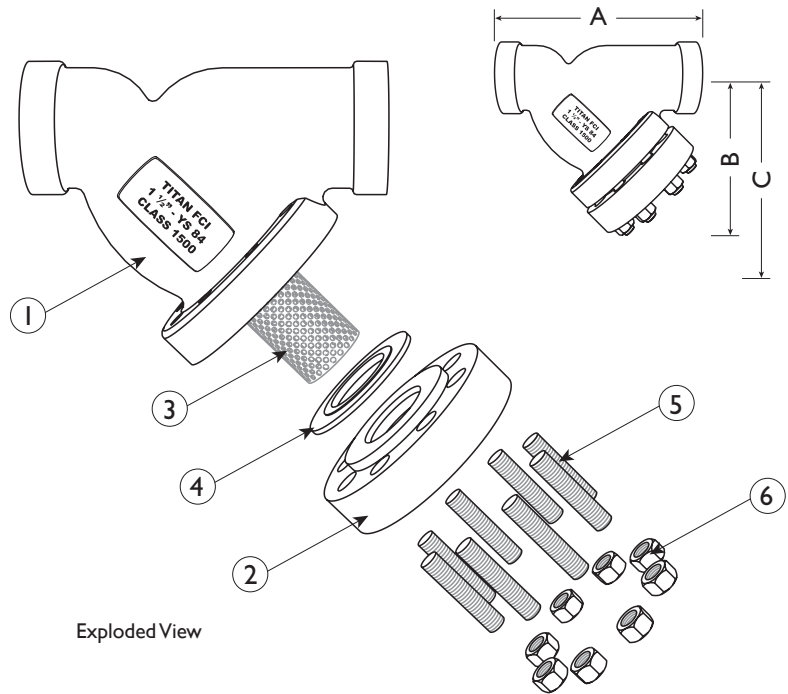

1. Bill of Materials represents standard materials. Equivalent or better materials may be substituted at the manufacturer's discretion.
2. Denotes recommended spare parts.
3. Carbon Steel bodies are epoxy painted.

Additional Design & Technical Notes:

- The YS 83 and YS 84 are dual rated for ANSI Class 900 and ANSI Class 1500
- NPT blow-offs are not recommended for ANSI Class 1500 strainers. An optional socket weld blow-off is available. Contact factory for details.
- A wide range of optional gasket materials are available.
- Bodies are also available in high temperature steel A217 Gr. WC6, WC9, and other materials. Please contact factory for price and delivery.

Illustrations are representative of sizes 1/2" through 3".
 Please ask for certified drawings when required.

DIMENSIONS AND PERFORMANCE DATA (1)

SIZE	in	1/2	3/4	1	1 1/4	1 1/2	2	2 1/2 (3)	3 (3)
	mm	15	20	25	32	40	50	65	80
A DIMENSION FACE TO FACE (2)	in	3.94	4.25	6.00	8.37	8.37	10.50	C/F	C/F
	mm	101	108	153	213	213	267	C/F	C/F
B DIMENSION CENTER LINE TO BOTTOM	in	3.00	3.75	5.75	5.50	5.50	9.25	C/F	C/F
	mm	77	96	147	140	140	235	C/F	C/F
C DIMENSION SCREEN REMOVAL	in	4.25	5.25	7.00	8.00	8.00	11.00	C/F	C/F
	mm	108	134	178	204	204	280	C/F	C/F
APPROXIMATE ASSEMBLED WEIGHT	lb	4.5	8.0	12.0	27.0	26.5	44.5	96.0	104.0
	kg	2.0	3.7	5.4	12.2	12.0	20.2	43.5	47.2
Flow Coefficient	C _v	6	11	16	32	34	60	140	140

1. Dimensions and weights are for reference only. When required, request certified drawings.
2. Face to face values have a tolerance of ±0.06 in (±2.0 mm) for sizes 10" and lower.
3. Contact factory before ordering a 2-1/2" or 3" to get dimensions and performance data.

PRESSURE - TEMPERATURE RATINGS

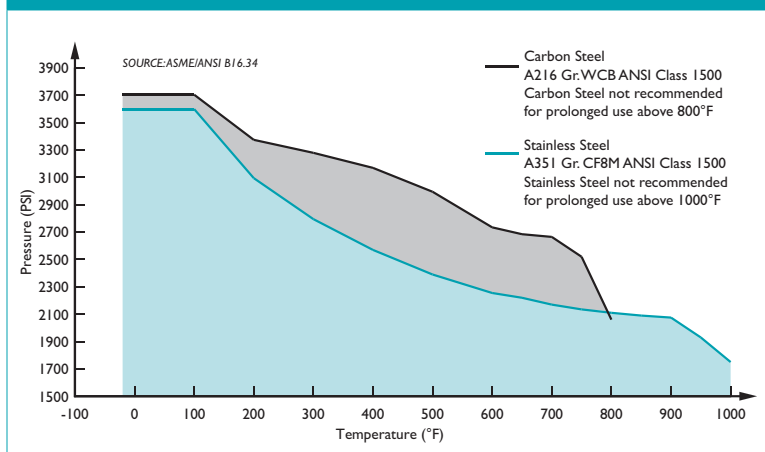

REFERENCED STANDARDS & CODES

CODE	DESCRIPTION
ASME/ANSI B16.11	Forged Steel Fittings, Socket-Welding & Threaded
ASME/ANSI B16.34	Flanged, Threaded, and Welding End

STANDARD SCREEN SELECTIONS

Size	Liquid	Open Area	Steam	Open Area
1/2" ~ 3"	1/16 (.0625)	41%	1/32 (.033)	28%

PRESSURE - TEMPERATURE RATING

Body Material	A216 Gr. WCB	A351 Gr. CF8M
WOG (Non-shock):	3705 PSI @ 100 °F	3600 PSI @ 100 °F

Titan FCI makes every effort to ensure the information presented on our literature accurately reflects exact product specifications. However, as product changes occur, there may be short-term differences between actual product specifications and the information contained within our literature. Titan FCI reserves the right to make design and specification changes to improve our products without prior notification. When required, request certified drawings.



TITAN FLOW CONTROL, INC.

"Y" (WYE) STRAINER ♦ SOCKET WELD ENDS

ANSI CLASS 2500 ♦ CARBON AND STAINLESS STEEL

MODELS: YS 86-CS

(CARBON STEEL)

YS 86-SS

(STAINLESS STEEL)

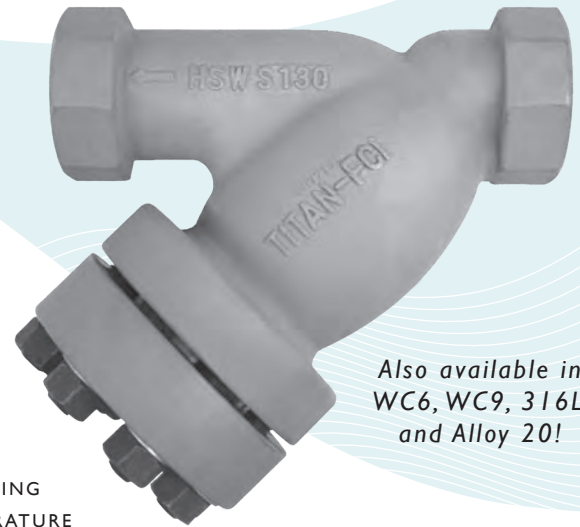

Also available in
WC6, WC9, 316L,
and Alloy 20!

FEATURES

SIZES: 3/4" ~ 2"

♦ RUGGED - HIGH QUALITY DESIGN

TITAN'S YS86 IS IDEAL FOR POWER GENERATION AND OTHER DEMANDING INDUSTRIAL APPLICATIONS THAT HAVE HIGHER PRESSURE AND TEMPERATURE REQUIREMENTS. THIS UNIT EMPLOYES HEAVY GAUGE, REINFORCED SCREENS TO PREVENT DAMAGE TO THE STRAINING ELEMENT. BOLT HOLES ARE ALSO BACK OR SPOT FACED.

♦ LARGE STRAINING CAPACITY

WITH ITS LARGE BODY AND SIZABLE STRAINING ELEMENT, THE YS86 PROVIDES EXCELLENT OPEN AREA RATIOS THAT ARE TYPICALLY TWO-AND-A-HALF TIMES LARGER THAN THE CORRESPONDING PIPELINE.

♦ PRECISION MACHINED SEATS

PRECISION MACHINED SCREEN SEATS IN BOTH THE BODY AND CAP HELP TO ENSURE ACCURATE POSITIONING OF THE SCREEN DURING REASSEMBLY AFTER CLEANING. ALSO, THE MACHINED BODY SEATS ENABLE FINER FILTRATION BY PREVENTING DEBRIS BYPASS.

♦ ENCAPSULATED "CG" STYLE GASKET

THE "CG" STYLE COVER GASKET PROVIDES ADDITIONAL RADIAL STRENGTH TO PREVENT GASKET BLOWOUT. IT ALSO ACTS AS A COMPRESSION STOP.

♦ SELF-CLEANING CAPABILITY

WITH THE OPTIONAL SOCKET WELD BLOW-OFF CONNECTION, THIS UNIT CAN BE FITTED WITH A BLOW-DOWN VALVE WHICH FACILITATES CLEANING OF THE STRAINING ELEMENT. PLEASE CONTACT FACTORY FOR MORE INFORMATION.

♦ EPOXY PAINTED

CARBON UNITS ARE EPOXY PAINTED TO HELP RESIST RUST AND CORROSION. TITAN FCI ALSO OFFERS EPOXY COATING. PLEASE CONTACT FACTORY FOR MORE INFORMATION.

TECHNICAL

PRESSURE/ TEMPERATURE RATING
CS - ASTM A216 GR. WCB - CLASS 2500

WOG (Non-shock): 6170 PSI @ 100 °F

PRESSURE/ TEMPERATURE RATING
SS - ASTM A351 GR. CF8M - CLASS 2500

WOG (Non-shock): 6000 PSI @ 100 °F

- The above listed temperatures are theoretical and may vary during actual operating conditions.
- Carbon Steel not recommended for prolonged use above 800 °F.
- Stainless Steel not recommended for prolonged use above 1000 °F.

APPLICATIONS

CARBON STEEL PROPERTIES: CARBON STEEL PERFORMS EXCEPTIONALLY WELL IN HIGH TEMPERATURES, UP TO 800°F IN CONTINUOUS SERVICE. IT PROVIDES HIGH RESISTANCE TO SHOCK, VIBRATION, PIPING STRAINS, AND FIRE AND FREEZING HAZARDS. CARBON STEEL STRAINERS ARE OFTEN USED IN THE OIL AND PETROCHEMICAL INDUSTRIES.

STAINLESS STEEL PROPERTIES: STAINLESS STEEL IS COMMONLY SPECIFIED FOR HIGH TEMPERATURE SERVICE, UP TO 1000°F IN CONTINUOUS SERVICE. STAINLESS STEEL STRAINERS ARE COMMONLY FOUND IN THE CHEMICAL, FOOD, AND PHARMACEUTICAL INDUSTRIES.

The above data represents common market and service applications. No representation or guarantee, expressed or implied, is given due to the numerous variations of concentrations, temperatures and flow conditions that may occur during actual service.

TITAN FLOW CONTROL, INC.

YOUR PIPELINE TO THE FUTURE!

Tel: 910-735-0000 ♦ Fax: 910-738-3848 ♦ titan@titanfci.com ♦ www.titanfci.com
290 Corporate Drive ♦ PO Box 7408 ♦ Lumberton, NC 28358



TITAN FLOW CONTROL, Inc.

290 Corporate Drive
Lumberton, NC 28358
Tel: 910.735.0000

E-mail: titan@titanfci.com
Web: www.titanfci.com
Fax: 910.738.3848

WYE STRAINER
YS 86-CS - (Carbon Steel)
YS 86-SS - (Stainless Steel)
Socket Weld Ends • Carbon & Stainless Steel

ANSI Class
2500

BILL OF MATERIALS (1)

No.	PART	YS 86-CS (3)	YS 86-SS
1	Body	Carbon Steel A216 Gr.WCB	Stainless Steel A351 Gr.CF8M Type 316
2	Cover	Carbon Steel A216 Gr.WCB	Stainless Steel A351 Gr.CF8M Type 316
3	Straining Element (2)	Stainless Steel	Stainless Steel
4	Gasket (2)	RTJ Gasket Stainless Steel	RTJ Gasket Stainless Steel
5	Studs	Alloy Steel	Alloy Steel
6	Nuts	Alloy Steel	Alloy Steel

1. Bill of Materials represents standard materials. Equivalent or better materials may be substituted at the manufacturer's discretion.
2. Denotes recommended spare parts.
3. Carbon Steel bodies are epoxy painted.

Additional Design & Technical Notes:

- An optional socket weld blow-off is available. Please contact factory.
- NPT blow-offs are not recommended for ANSI Class 2500 strainers.
- Bodies are also available in WC6, WC9, 316L, and Alloy 20. Please contact factory for price and delivery.

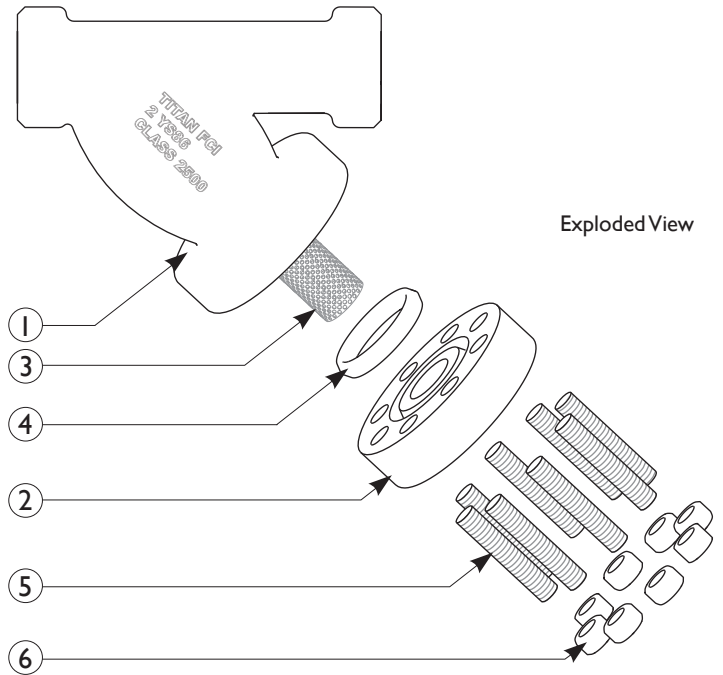

Exploded View

Illustrations are representative of a YS 86.
Please ask for certified drawings when required.

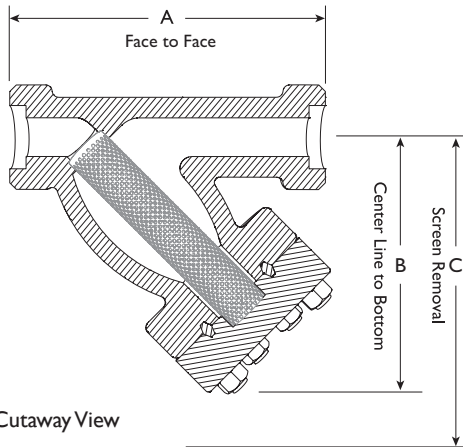

Cutaway View

DIMENSIONS AND PERFORMANCE DATA (1)

SIZE	in	3/4	1	1 1/2	2
	mm	20	25	40	50
A DIMENSION FACE TO FACE (2)	in	9.25	9.25	12.0	12.0
	mm	235	235	305	305
B DIMENSION CENTER LINE TO BOTTOM	in	8.55	8.55	9.0	9.0
	mm	217	217	229	229
C DIMENSION SCREEN REMOVAL	in	11.0	11.0	14.0	14.0
	mm	279	279	356	356
APPROXIMATE ASSEMBLED WEIGHT	lb	34.5	31.0	75.0	75.0
	kg	16.7	14.1	34.0	34.0
Flow Coefficient	C _v	9	9	30	42

1. Dimensions, weights, and flow coefficients are for reference only. When required, request certified drawings.
2. Face to face values have a tolerance of ±0.06 in (±2.0 mm).

PRESSURE - TEMPERATURE RATINGS

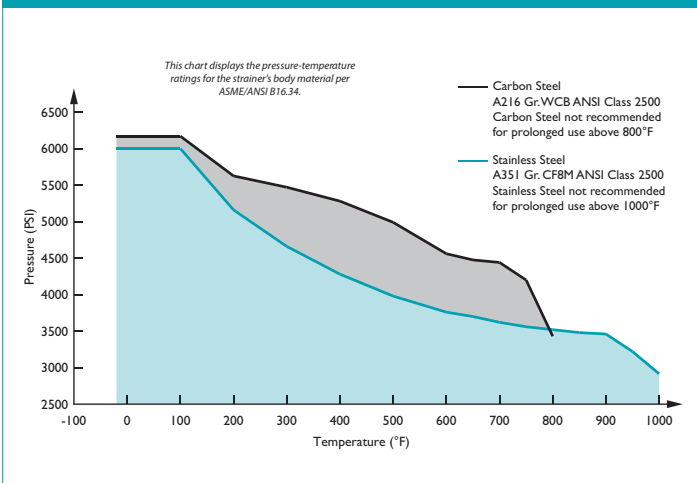

PRESSURE - TEMPERATURE RATING

Body Material	A216 Gr.WCB	A351 Gr. CF8M
WOG (Non-shock):	6170 PSI @ 100 °F	6000 PSI @ 100 °F

STANDARD SCREEN SELECTIONS

Size	Liquid	Open Area	Steam	Open Area
3/4" ~ 2"	1/16 (.0625)	41%	1/32 (.033)	28%

REFERENCED STANDARDS & CODES

CODE	DESCRIPTION
ASME/ANSI B16.11	Forged Steel Fittings, Socket-Welding and Threaded
ASME/ANSI B16.34	Flanged, Threaded, and Welding End

Titan FCI makes every effort to ensure the information presented on our literature accurately reflects exact product specifications. However, as product changes occur, there may be short-term differences between actual product specifications and the information contained within our literature. Titan FCI reserves the right to make design and specification changes to improve our products without prior notification. When required, request certified drawings.



TITAN FLOW CONTROL, INC.

"Y" (WYE) STRAINER ♦ FLANGED ENDS, RAISED FACE

ANSI CLASS 150 ♦ CARBON AND STAINLESS STEEL

NEWLY DESIGNED...
Gauge Taps

STANDARD ON ALL
YS 61 MODELS IN
SIZES 2" ~ 24"

MODELS: YS 61-CS

(CARBON STEEL)

YS 61-SS

(STAINLESS STEEL)

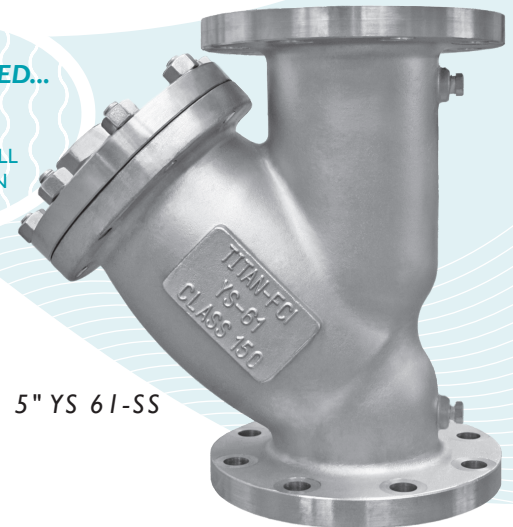

5" YS 61-SS

FEATURES

SIZE RANGE: 1/2" ~ 24"

- ♦ **NEW DESIGN WITH GAUGE TAPS**
TITAN'S YS61 HAS CONVENIENT GAUGE TAPS FURNISHED WITH A PLUG ON BOTH THE INLET AND OUTLET SIDES OF SIZES 2" THROUGH 24". THESE TAPS ALLOW FOR EASY INSTALLATION OF PRESSURE GAUGES TO MONITOR DIFFERENTIAL PRESSURE AND DETERMINE WHEN SCREEN CLEANING IS NECESSARY.
- ♦ **LARGE STRAINING CAPACITY**
WITH ITS LARGE BODY AND SIZABLE STRAINING ELEMENT, THE YS61 PROVIDES EXCELLENT OPEN AREA RATIOS THAT ARE TYPICALLY TWO-AND-A-HALF TIMES LARGER THAN THE CORRESPONDING PIPELINE.
- ♦ **PRECISION MACHINED SEATS**
PRECISION MACHINED SCREEN SEATS IN BOTH THE BODY AND CAP HELP TO ENSURE ACCURATE POSITIONING OF THE SCREEN DURING REASSEMBLY AFTER CLEANING. ALSO, THE MACHINED BODY SEATS ENABLE FINER FILTRATION BY PREVENTING DEBRIS BYPASS.
- ♦ **SELF-CLEANING CAPABILITY**
WITH A TAPPED NPT BLOW-OFF CONNECTION, THIS UNIT CAN BE FITTED WITH A BLOW-DOWN VALVE WHICH FACILITATES CLEANING OF THE STRAINING ELEMENT. PLEASE CONTACT FACTORY FOR MORE INFORMATION.
- ♦ **EPOXY PAINTED**
CARBON STEEL UNITS ARE EPOXY PAINTED TO HELP RESIST RUST AND CORROSION. TITAN FCI ALSO OFFERS EPOXY COATING AS AN OPTION FOR THE YS61.
- ♦ **OPTIONAL COVER DESIGNS**
TITAN'S YS61 IS AVAILABLE WITH DIFFERENT COVER OPTIONS INCLUDING SWING, CLAMP, AND HINGE TYPE COVERS. PLEASE CONSULT FACTORY FOR MORE INFORMATION ON THESE OPTIONS.

TECHNICAL

PRESSURE/TEMPERATURE RATING
CS - ASTM A216 GR. WCB - CLASS 150

WOG (Non-shock): 285 PSI @ 100 °F

PRESSURE/TEMPERATURE RATING
SS - ASTM A351 GR. CF8M - CLASS 150

WOG (Non-shock): 275 PSI @ 100 °F

- The above listed temperatures are theoretical and may vary during actual operating conditions.
- Carbon Steel not recommended for prolonged use above 800 °F.
- Stainless Steel not recommended for prolonged use above 1000 °F.

APPLICATIONS

CARBON STEEL PROPERTIES: CARBON STEEL PERFORMS EXCEPTIONALLY WELL IN HIGH TEMPERATURES, UP TO 800°F IN CONTINUOUS SERVICE. IT PROVIDES HIGH RESISTANCE TO SHOCK, VIBRATION, PIPING STRAINS, AND FIRE AND FREEZING HAZARDS. CARBON STEEL STRAINERS ARE OFTEN USED IN THE OIL AND PETROCHEMICAL INDUSTRIES.

STAINLESS STEEL PROPERTIES: STAINLESS STEEL IS COMMONLY SPECIFIED FOR HIGH TEMPERATURE SERVICE, UP TO 1000°F IN CONTINUOUS SERVICE. STAINLESS STEEL STRAINERS ARE COMMONLY FOUND IN THE CHEMICAL, FOOD, AND PHARMACEUTICAL INDUSTRIES.

The above data represents common market and service applications. No representation or guarantee, expressed or implied, is given due to the numerous variations of concentrations, temperatures and flow conditions that may occur during actual service.

TITAN FLOW CONTROL, INC.
YOUR PIPELINE TO THE FUTURE!

Tel: 910-735-0000 ♦ Fax: 910-738-3848 ♦ titan@titanfci.com ♦ www.titanfci.com
290 Corporate Drive ♦ PO Box 7408 ♦ Lumberton, NC 28358



TITAN FLOW CONTROL, Inc.

290 Corporate Drive
Lumberton, NC 28358
Tel: 910.735.0000

E-mail: titan@titanfci.com
Web: www.titanfci.com
Fax: 910.738.3848

WYE STRAINER

YS 61-CS - (Carbon Steel)
YS 61-SS - (Stainless Steel)

Flanged Ends • Raised Face • Carbon & Stainless Steel

ANSI Class 150

BILL OF MATERIALS ⁽¹⁾

No.	PART	YS 61-CS ⁽⁶⁾	YS 61-SS
1	Body ⁽²⁾	Carbon Steel A216 Gr. WCB	Stainless Steel A351 Gr. CF8M
2	Cover	Carbon Steel A216 Gr. WCB	Stainless Steel A351 Gr. CF8M
3	Straining Element ⁽³⁾	Stainless Steel	Stainless Steel
4	Gasket ^{(3) (4)}	Stainless Steel Spiral Wound	Stainless Steel Spiral Wound
5	Studs	Alloy Steel	Stainless Steel
6	Nuts	Alloy Steel	Stainless Steel
7	NPT Plug Blow-off	Carbon Steel	Stainless Steel
8	NPT Plug Gauge Taps ⁽⁵⁾	Carbon Steel	Stainless Steel

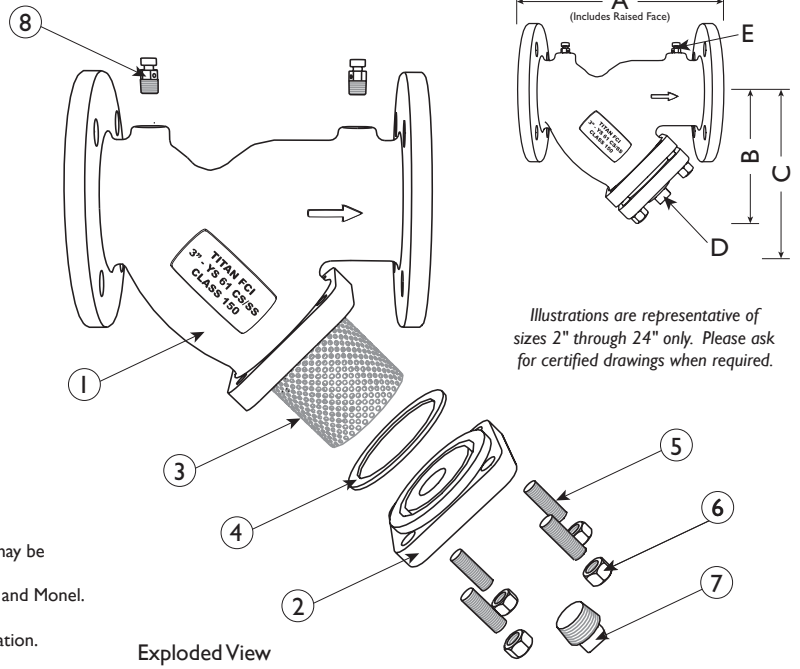

- Bill of Materials represents standard materials. Equivalent or better materials may be substituted at the manufacturer's discretion.
- Available in additional body materials, such as LCB, WC6, WC9, 316L, Alloy 20, and Monel.
- Denotes recommended spare parts.
- A wide range of gasket materials are available; contact factory for more information.
- Part number 8 (NPT Plug - Gauge Taps) only applies to sizes 2" through 24".
- Carbon Steel bodies are epoxy painted.

DIMENSIONS AND PERFORMANCE DATA ⁽¹⁾

SIZE		in	1/2	3/4	1	1 1/4	1 1/2	2	2 1/2	3	4	5	6	8	10	12	14	16	18	20	24
		mm	15	20	25	32	40	50	65	80	100	125	150	200	250	300	350	400	450	500	600
A DIMENSION FACETO FACE ⁽²⁾	in	6.50	7.37	7.37	7.00	7.12	7.87	9.75	10.06	12.12	15.62	18.50	21.37	26.00	29.87	36.00	41.75	46.00	49.50	58.37	
	mm	166	188	188	178	181	200	248	256	308	397	470	543	661	759	914	1060	1168	1257	1483	
B DIMENSION CENTER LINE TO BOTTOM	in	3.50	3.75	3.75	4.75	4.75	5.25	6.50	7.00	8.25	11.25	13.50	15.50	18.50	22.25	25.00	26.50	31.00	39.00	45.00	
	mm	89	96	96	121	121	134	166	178	210	286	343	394	470	566	625	673	787	991	1143	
C DIMENSION SCREEN REMOVAL	in	5.00	5.00	5.00	7.00	7.00	7.00	9.75	10.00	12.00	20.00	20.00	22.75	28.00	30.00	36.50	42.00	45.50	56.00	68.00	
	mm	127	127	127	178	178	178	248	254	305	508	508	578	712	762	927	1067	1156	1422	1727	
D NPT Plug BLOW-OFF	in	3/8	1/2	1/2	1/2	1/2	1/2	1	1	1 1/2	2	2	2	2	2	2	2	2	2	2	
	mm	10	15	15	15	15	15	25	25	40	50	50	50	50	50	50	50	50	50	50	
E NPT Plug GAUGE TAPS	in	N/A	N/A	N/A	N/A	N/A	1/4	1/4	1/4	1/4	1/4	1/4	1/4	1/4	1/4	1/4	1/4	1/4	1/4	1/4	
	mm	N/A	N/A	N/A	N/A	N/A	8	8	8	8	8	8	8	8	8	8	8	8	8	8	
ASSEMBLED WEIGHT APPROXIMATE	lb	5.5	10.3	10.3	12.0	12.5	21.0	32.0	35.0	55.0	90.0	140.0	220.0	356.0	644.0	1000	1090	2400	2700	3340	
	kg	2.5	4.6	4.6	5.4	5.7	9.5	14.5	15.9	24.9	40.8	63.5	99.7	161.5	292.1	453.6	494.4	1089	1225	1515	
Flow Coefficient	C _v	C/F	C/F	C/F	C/F	C/F	42	70	110	160	260	400	570	950	1600	2200	3300	4900	6100	8000	11000

- Dimensions and weights are for reference only. When required, request certified drawings.
- Face to face dimension includes raised face. These values have a tolerance of ±0.06 in (±2.0 mm) for sizes 10" and lower and a tolerance of ±0.12 in (±3.0 mm) for sizes 12" and larger.

REFERENCED STANDARDS & CODES

CODE	DESCRIPTION
ASME/ANSI B16.5	Pipe Flanges and Flanged Fittings
ASME/ANSI B16.34	Flanged, Threaded, and Welding End

STANDARD SCREEN SELECTIONS

Size	Liquid	Open Area	Steam	Open Area
1/2" - 4"	1/16 (.0625)	41%	1/32 (.033)	28%
5" - 8"	1/8 (.125)	40%	3/64 (.045)	36%
10" - 12"	1/8 (.125)	40%	30 Mesh Lined	44.8%

PRESSURE - TEMPERATURE RATING

Body Material	A216 Gr. WCB	A351 Gr. CF8M
WOG (Non-shock):	285 PSI @ 100 °F	275 PSI @ 100 °F

PRESSURE - TEMPERATURE RATINGS

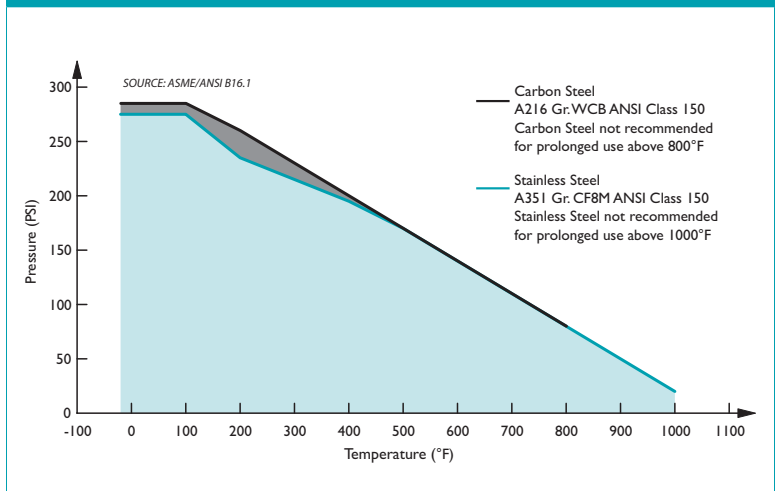

Titan FCI makes every effort to ensure the information presented on our literature accurately reflects exact product specifications. However, as product changes occur, there may be short-term differences between actual product specifications and the information contained within our literature. Titan FCI reserves the right to make design and specification changes to improve our products without prior notification. When required, request certified drawings.



TITAN FLOW CONTROL, INC.

"Y" (WYE) STRAINER ♦ FLANGED ENDS, RAISED FACE

ANSI CLASS 300 ♦ CARBON AND STAINLESS STEEL

NEWLY DESIGNED... Gauge Taps

STANDARD ON ALL
YS 62 MODELS IN
SIZES 2" ~ 12"

MODELS: **YS 62-CS**
(CARBON STEEL)

YS 62-SS
(STAINLESS STEEL)

6" YS 62-SS

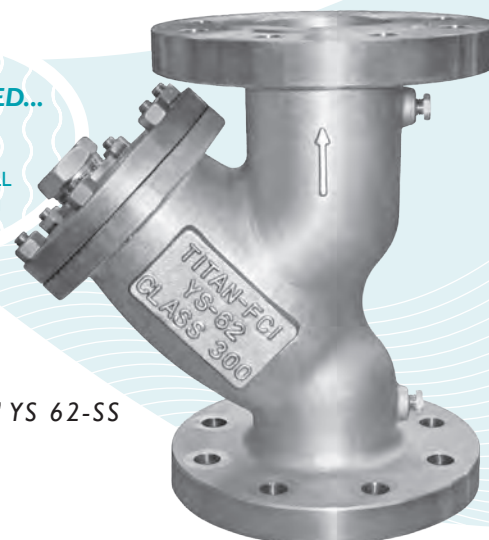

FEATURES

SIZE RANGE: 1/2" ~ 12"

◆ NEW DESIGN WITH GAUGE TAPS

TITAN'S YS62 HAS CONVENIENT GAUGE TAPS FURNISHED WITH A PLUG ON BOTH THE INLET AND OUTLET SIDES OF SIZES 2" THROUGH 12". THESE TAPS ALLOW FOR EASY INSTALLATION OF PRESSURE GAUGES TO MONITOR DIFFERENTIAL PRESSURE AND DETERMINE WHEN SCREEN CLEANING IS NECESSARY.

◆ LARGE STRAINING CAPACITY

WITH ITS LARGE BODY AND SIZABLE STRAINING ELEMENT, THE YS62 PROVIDES EXCELLENT OPEN AREA RATIOS THAT ARE TYPICALLY TWO-AND-A-HALF TIMES LARGER THAN THE CORRESPONDING PIPELINE.

◆ PRECISION MACHINED SEATS

PRECISION MACHINED SCREEN SEATS IN BOTH THE BODY AND CAP HELP TO ENSURE ACCURATE POSITIONING OF THE SCREEN DURING REASSEMBLY AFTER CLEANING. ALSO, THE MACHINED BODY SEATS ENABLE FINER FILTRATION BY PREVENTING DEBRIS BYPASS.

◆ SELF-CLEANING CAPABILITY

WITH A TAPPED NPT BLOW-OFF CONNECTION, THIS UNIT CAN BE FITTED WITH A BLOW-DOWN VALVE WHICH FACILITATES CLEANING OF THE STRAINING ELEMENT. PLEASE CONTACT FACTORY FOR MORE INFORMATION.

◆ EPOXY PAINTED

CARBON STEEL UNITS ARE EPOXY PAINTED TO HELP RESIST RUST AND CORROSION. TITAN FCI ALSO OFFERS EPOXY COATING AS AN OPTION FOR THE YS62.

◆ OPTIONAL COVER DESIGNS

TITAN'S YS62 IS AVAILABLE WITH DIFFERENT COVER OPTIONS INCLUDING SWING, CLAMP, AND HINGE TYPE COVERS. PLEASE CONSULT FACTORY FOR MORE INFORMATION ON THESE OPTIONS.

TECHNICAL

PRESSURE/TEMPERATURE RATING
CS - ASTM A216 GR. WCB - CLASS 300

WOG (Non-shock): 740 PSI @ 100 °F

PRESSURE/TEMPERATURE RATING
SS - ASTM A351 GR. CF8M - CLASS 300

WOG (Non-shock): 720 PSI @ 100 °F

- The above listed temperatures are theoretical and may vary during actual operating conditions.
- Carbon Steel not recommended for prolonged use above 800 °F.
- Stainless Steel not recommended for prolonged use above 1000 °F.

APPLICATIONS

CARBON STEEL PROPERTIES: CARBON STEEL PERFORMS EXCEPTIONALLY WELL IN HIGH TEMPERATURES, UP TO 800°F IN CONTINUOUS SERVICE. IT PROVIDES HIGH RESISTANCE TO SHOCK, VIBRATION, PIPING STRAINS, AND FIRE AND FREEZING HAZARDS. CARBON STEEL STRAINERS ARE OFTEN USED IN THE OIL AND PETROCHEMICAL INDUSTRIES.

STAINLESS STEEL PROPERTIES: STAINLESS STEEL IS COMMONLY SPECIFIED FOR HIGH TEMPERATURE SERVICE, UP TO 1000°F IN CONTINUOUS SERVICE. STAINLESS STEEL STRAINERS ARE COMMONLY FOUND IN THE CHEMICAL, FOOD, AND PHARMACEUTICAL INDUSTRIES.

The above data represents common market and service applications. No representation or guarantee, expressed or implied, is given due to the numerous variations of concentrations, temperatures and flow conditions that may occur during actual service.

TITAN FLOW CONTROL, INC.

YOUR PIPELINE TO THE FUTURE!

Tel: 910-735-0000 ♦ Fax: 910-738-3848 ♦ titan@titanfci.com ♦ www.titanfci.com
290 Corporate Drive ♦ PO Box 7408 ♦ Lumberton, NC 28358



TITAN FLOW CONTROL, Inc.

290 Corporate Drive
Lumberton, NC 28358
Tel: 910.735.0000

E-mail: titan@titanfci.com
Web: www.titanfci.com
Fax: 910.738.3848

WYE STRAINER
YS 62-CS - (Carbon Steel)
YS 62-SS - (Stainless Steel)
Flanged Ends • Raised Face • Carbon & Stainless Steel

ANSI Class
300

BILL OF MATERIALS (1)

No.	PART	YS 62-CS (5)	YS 62-SS
1	Body (2)	Carbon Steel A216 Gr. WCB	Stainless Steel A351 Gr. CF8M
2	Cover	Carbon Steel A216 Gr. WCB	Stainless Steel A351 Gr. CF8M
3	Straining Element (3)	Stainless Steel	Stainless Steel
4	Gasket (3)	Stainless Steel Spiral Wound	Stainless Steel Spiral Wound
5	Studs	Alloy Steel	Stainless Steel
6	Nuts	Carbon Steel	Stainless Steel
7	NPT Plug Blow-off	Carbon Steel	Stainless Steel
8	NPT Plug Gauge Taps (4)	Carbon Steel	Stainless Steel

- Bill of Materials represents standard materials. Equivalent or better materials may be substituted at the manufacturer's discretion.
- Available in additional body materials, such as LCB, WC6, WC9, 316L, Alloy 20, and Monel.
- Denotes recommended spare parts.
- Part number 8 (NPT Plug - Gauge Taps) only applies to sizes 2" through 12".
- Carbon Steel bodies are epoxy painted.

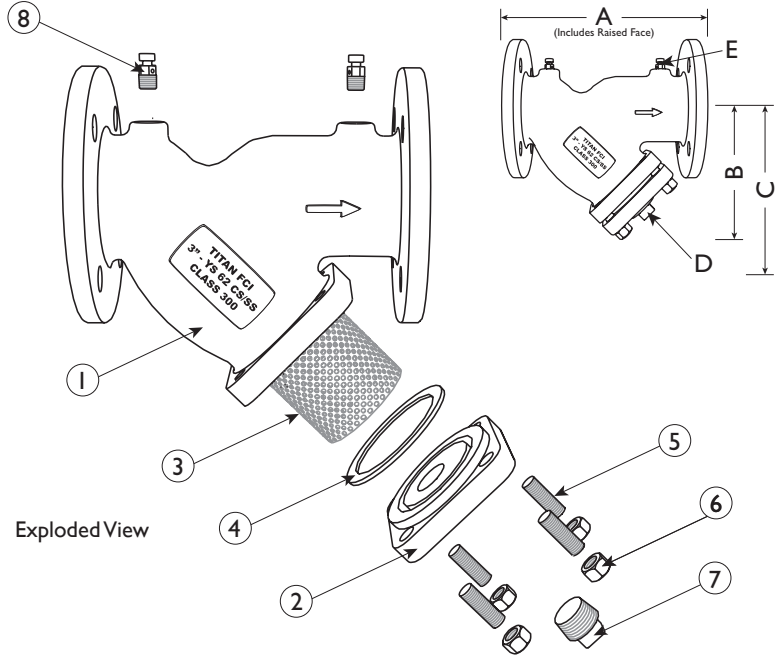

Exploded View

Illustrations are representative of sizes 2" through 12" only. Please ask for certified drawings when required.

DIMENSIONS AND PERFORMANCE DATA (1)

SIZE	in	1/2	3/4	1	1 1/4	1 1/2	2	2 1/2	3	4	5	6	8	10	12
	mm	15	20	25	32	40	50	65	80	100	125	150	200	250	300
A DIMENSION FACE TO FACE (2)	in	6.62	8.31	8.31	10.12	10.25	9.62	10.62	12.00	14.50	19.31	19.31	23.37	27.37	32.00
	mm	169	212	212	258	261	245	270	305	369	491	491	594	696	813
B DIMENSION CENTER LINE TO BOTTOM	in	3.50	3.75	3.75	5.50	5.50	5.25	6.50	7.00	8.25	11.25	13.50	15.50	18.50	21.75
	mm	89	96	96	140	140	134	166	178	210	286	343	394	470	553
C DIMENSION SCREEN REMOVAL	in	5.00	5.00	5.00	8.00	8.00	7.00	9.75	10.00	12.00	17.00	20.00	22.75	28.00	30.00
	mm	127	127	127	204	204	178	248	254	305	432	508	578	712	762
D NPT Plug BLOW-OFF	in	3/8	1/2	1/2	1/2	1/2	1/2	1	1	1 1/2	2	2	2	2	2
	mm	10	15	15	15	15	15	25	25	40	50	50	50	50	50
E NPT Plug GAUGE TAPS	in	N/A	N/A	N/A	N/A	N/A	1/4	1/4	1/4	1/4	1/4	1/4	1/4	1/4	1/4
	mm	N/A	N/A	N/A	N/A	N/A	8	8	8	8	8	8	8	8	8
ASSEMBLED WEIGHT APPROXIMATE	lb	7.5	10.0	13.5	26.0	25.0	26.0	40.0	52.5	94.0	161.5	185.5	260.0	408.0	632.0
	kg	3.4	4.5	6.1	11.8	11.3	11.8	18.1	23.8	42.6	73.2	84.1	117.9	185.1	286.7
Flow Coefficient	C _v	C/F	C/F	C/F	C/F	42	70	110	160	260	400	570	950	1600	2200

- Dimensions and weights are for reference only. When required, request certified drawings.
- Face to face values have a tolerance of ±0.06 in (±2.0 mm) for sizes 10" and lower and a tolerance of ±0.12 in (±3.0 mm) for sizes 12" and larger.

PRESSURE - TEMPERATURE RATING

Body Material	A216 Gr. WCB	A351 Gr. CF8M
WOG (Non-shock):	740 PSI @ 100 °F	720 PSI @ 100 °F

STANDARD SCREEN SELECTIONS

Size	Liquid	Open Area	Steam	Open Area
1/2" - 4"	1/16 (.0625)	41%	1/32 (.033)	28%
5" - 8"	1/8 (.125)	40%	3/64 (.045)	36%
10" - 12"	1/8 (.125)	40%	30 Mesh Lined	44.8%

REFERENCED STANDARDS & CODES

CODE	DESCRIPTION
ASME/ANSI B16.5	Pipe Flanges and Flanged Fittings
ASME/ANSI B16.34	Flanged, Threaded, and Welding End

PRESSURE - TEMPERATURE RATINGS

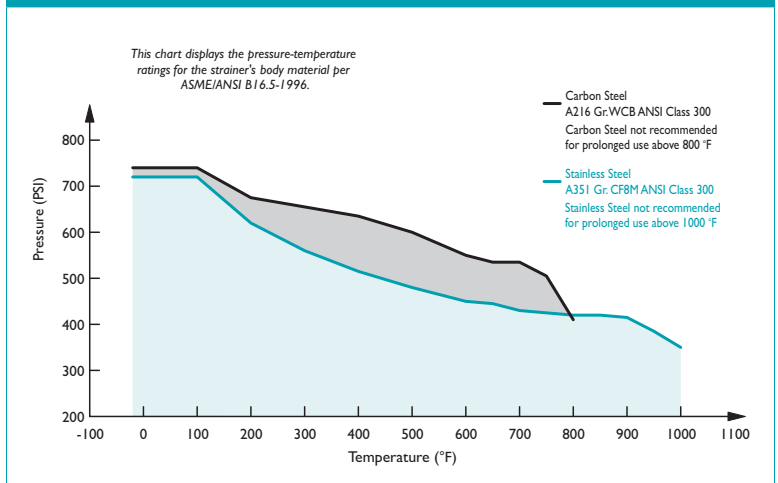

Titan FCI makes every effort to ensure the information presented on our literature accurately reflects exact product specifications. However, as product changes occur, there may be short-term differences between actual product specifications and the information contained within our literature. Titan FCI reserves the right to make design and specification changes to improve our products without prior notification. When required, request certified drawings.



TITAN FLOW CONTROL, INC.

"Y" (WYE) STRAINER ♦ BUTT WELD ENDS

ANSI CLASS 300 ♦ CARBON AND STAINLESS STEEL

MODELS: YS 63-CS

(CARBON STEEL)

YS 63-SS

(STAINLESS STEEL)

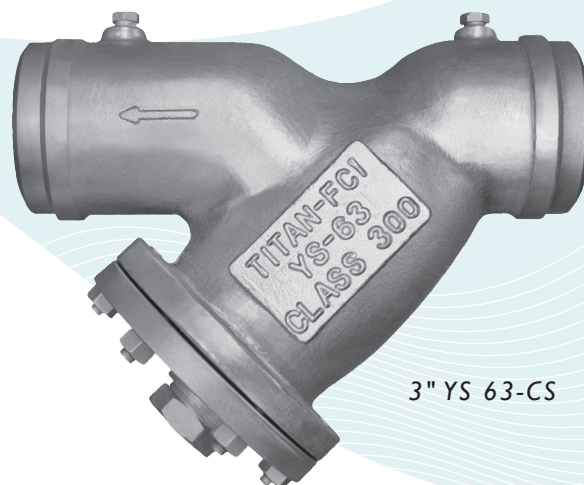

3" YS 63-CS

FEATURES

SIZE RANGE: 1/2" ~ 12"

- ♦ **LARGE STRAINING CAPACITY**
WITH ITS LARGE BODY AND SIZABLE STRAINING ELEMENT, THE YS63 PROVIDES EXCELLENT OPEN AREA RATIOS THAT ARE TYPICALLY TWO-AND-A-HALF TIMES LARGER THAN THE CORRESPONDING PIPELINE.
- ♦ **PRECISION MACHINED SEATS**
PRECISION MACHINED SCREEN SEATS IN BOTH THE BODY AND CAP HELP TO ENSURE ACCURATE POSITIONING OF THE SCREEN DURING REASSEMBLY AFTER CLEANING. ALSO, THE MACHINED BODY SEATS ENABLE FINER FILTRATION BY PREVENTING DEBRIS BYPASS.
- ♦ **SELF-CLEANING CAPABILITY**
WITH A TAPPED NPT BLOW-OFF CONNECTION, THIS UNIT CAN BE FITTED WITH A BLOW-DOWN VALVE WHICH FACILITATES CLEANING OF THE STRAINING ELEMENT. PLEASE CONTACT FACTORY FOR MORE INFORMATION.
- ♦ **EPOXY PAINTED**
CARBON STEEL UNITS ARE EPOXY PAINTED TO HELP RESIST RUST AND CORROSION. TITAN FCI ALSO OFFERS EPOXY COATING AS AN OPTION FOR THE YS63.
- ♦ **OPTIONAL COVER DESIGNS**
TITAN'S YS63 IS AVAILABLE WITH DIFFERENT COVER OPTIONS INCLUDING SWING, CLAMP, AND HINGE TYPE COVERS. PLEASE CONSULT FACTORY FOR MORE INFORMATION ON THESE OPTIONS.
- ♦ **GAUGE TAPS AVAILABLE**
PLEASE REQUEST GAUGE TAPS (AS SHOWN IN PICTURE) WHEN REQUIRED. GAUGE TAPS MAY BE STANDARD ON SOME MODELS. FOR MORE INFORMATION, CONSULT FACTORY.

TECHNICAL

PRESSURE/TEMPERATURE RATING
CS - ASTM A216 GR. WCB - CLASS 300

WOG (Non-shock): 740 PSI @ 100 °F

PRESSURE/TEMPERATURE RATING
SS - ASTM A351 GR. CF8M - CLASS 300

WOG (Non-shock): 720 PSI @ 100 °F

- The above listed temperatures are theoretical and may vary during actual operating conditions.
- Carbon Steel not recommended for prolonged use above 800 °F.
- Stainless Steel not recommended for prolonged use above 1000 °F.

APPLICATIONS

CARBON STEEL PROPERTIES: CARBON STEEL PERFORMS EXCEPTIONALLY WELL IN HIGH TEMPERATURES, UP TO 800°F IN CONTINUOUS SERVICE. IT PROVIDES HIGH RESISTANCE TO SHOCK, VIBRATION, PIPING STRAINS, AND FIRE AND FREEZING HAZARDS. CARBON STEEL STRAINERS ARE OFTEN USED IN THE OIL AND PETROCHEMICAL INDUSTRIES.

STAINLESS STEEL PROPERTIES: STAINLESS STEEL IS COMMONLY SPECIFIED FOR HIGH TEMPERATURE SERVICE, UP TO 1000°F IN CONTINUOUS SERVICE. STAINLESS STEEL STRAINERS ARE COMMONLY FOUND IN THE CHEMICAL, FOOD, AND PHARMACEUTICAL INDUSTRIES.

The above data represents common market and service applications. No representation or guarantee, expressed or implied, is given due to the numerous variations of concentrations, temperatures and flow conditions that may occur during actual service.

TITAN FLOW CONTROL, INC.
YOUR PIPELINE TO THE FUTURE!

Tel: 910-735-0000 ♦ Fax: 910-738-3848 ♦ titan@titanfci.com ♦ www.titanfci.com
290 Corporate Drive ♦ PO Box 7408 ♦ Lumberton, NC 28358



TITAN FLOW CONTROL, Inc.

290 Corporate Drive
Lumberton, NC 28358
Tel: 910.735.0000

E-mail: titan@titanfci.com
Web: www.titanfci.com
Fax: 910.738.3848

WYE STRAINER

YS 63-CS - (Carbon Steel)
YS 63-SS - (Stainless Steel)

Butt Welded Ends • Carbon & Stainless Steel

ANSI Class
300

BILL OF MATERIALS ⁽¹⁾

No.	PART	YS 63-CS ⁽⁵⁾	YS 63-SS
1	Body ⁽²⁾	Carbon Steel A216 Gr. WCB	Stainless Steel A351 Gr. CF8M
2	Cover	Carbon Steel A216 Gr. WCB	Stainless Steel A351 Gr. CF8M
3	Straining Element ⁽³⁾	Stainless Steel	Stainless Steel
4	Gasket ^{(3) (4)}	Stainless Steel Spiral Wound	Stainless Steel Spiral Wound
5	Studs	Alloy Steel	Stainless Steel
6	Nuts	Carbon Steel	Stainless Steel
7	NPT Plug Blow-off	Carbon Steel	Stainless Steel

- Bill of Materials represents standard materials. Equivalent or better materials may be substituted at the manufacturer's discretion.
- Available in additional body materials, such as LCB, WC6, WC9, 316L, Alloy 20, and Monel.
- Denotes recommended spare parts.
- The cover gasket is encapsulated in a machined recessed seat. A wide range of gasket materials are available; contact factory.
- Carbon Steel bodies are epoxy painted.

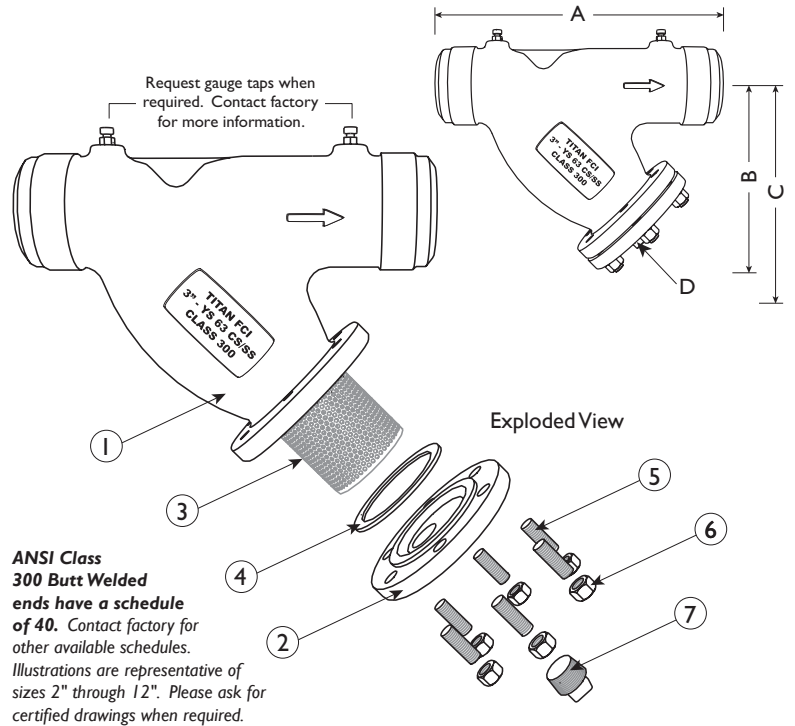

DIMENSIONS AND PERFORMANCE DATA ⁽¹⁾

SIZE	in	1/2	3/4	1	1 1/4	1 1/2	2	2 1/2	3	4	5	6	8	10	12	
	mm	15	20	25	32	40	50	65	80	100	125	150	200	250	300	
A DIMENSION FACE TO FACE ⁽²⁾	in	C/F	C/F	7.875	C/F	C/F	8.625	10.625	12.0	14.5	16.375	19.313	23.375	27.375	32.25	
	mm	C/F	C/F	200	C/F	C/F	219	270	305	368	416	491	594	695	813	
B DIMENSION CENTER LINE TO BOTTOM	in	C/F	C/F	5.5	C/F	C/F	5.25	6.5	7.0	8.25	11.25	13.5	15.75	19.0	22.25	
	mm	C/F	C/F	140	C/F	C/F	133	165	178	210	286	343	400	483	565	
C DIMENSION SCREEN REMOVAL	in	C/F	C/F	8.125	C/F	C/F	7.0	9.75	10.0	12.0	17.0	20.0	22.75	28.0	30.0	
	mm	C/F	C/F	206	C/F	C/F	178	248	254	305	432	508	578	711	762	
D NPT Plug BLOW-OFF	in	C/F	C/F	1/2	C/F	C/F	1/2	1	1	1 1/2	2	2	2	2	2	
	mm	C/F	C/F	15	C/F	C/F	15	25	25	40	50	50	50	50	50	
ASSEMBLED WEIGHT APPROXIMATE	lb	C/F	C/F	6.0	C/F	C/F	12.0	20.5	28.0	51.0	73.5	126.0	214.0	268.0	480.0	
	kg	C/F	C/F	2.7	C/F	C/F	5.4	9.3	12.7	23.1	33.3	57.1	97.1	121.6	217.7	
Flow Coefficient	C _v	C/F	C/F	C/F	C/F	C/F	42	70	110	160	260	400	570	950	1600	2200

- Dimensions and weights are for reference only. When required, request certified drawings.
- Face to face values have a tolerance of ±0.06 in (±2.0 mm) for sizes 10" and lower and a tolerance of ±0.12 in (±3.0 mm) for sizes 12" and larger.

REFERENCED STANDARDS & CODES

CODE	DESCRIPTION
ASME/ANSI B16.25	Buttwelding Ends
ASME/ANSI B16.34	Flanged, Threaded, and Welding End

STANDARD SCREEN SELECTIONS

Size	Liquid	Open Area	Steam	Open Area
1/2" - 4"	1/16 (.0625)	41%	1/32 (.033)	28%
5" - 8"	1/8 (.125)	40%	3/64 (.045)	36%
10" - 12"	1/8 (.125)	40%	30 Mesh Lined	44.8%

PRESSURE - TEMPERATURE RATING

Body Material	A216 Gr. WCB	A351 Gr. CF8M
WOG (Non-shock):	740 PSI @ 100 °F	720 PSI @ 100 °F

PRESSURE - TEMPERATURE RATINGS

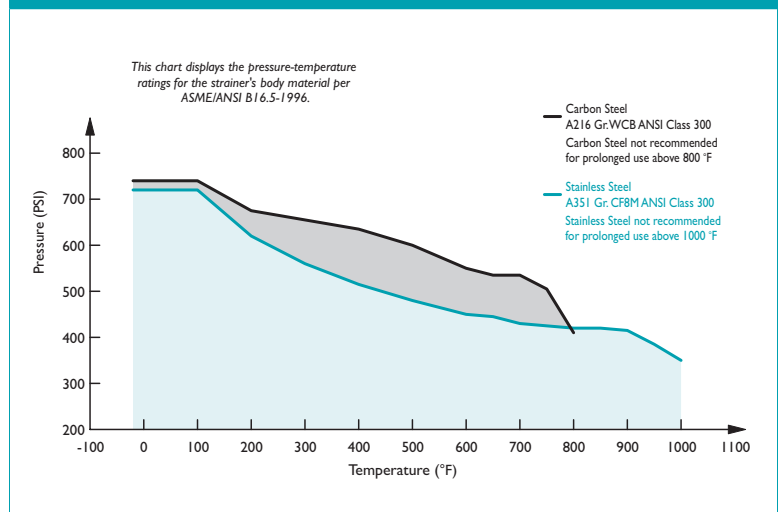

Titan FCI makes every effort to ensure the information presented on our literature accurately reflects exact product specifications. However, as product changes occur, there may be short-term differences between actual product specifications and the information contained within our literature. Titan FCI reserves the right to make design and specification changes to improve our products without prior notification. When required, request certified drawings.



TITAN FLOW CONTROL, INC.

"Y" (WYE) STRAINER ♦ FLANGED ENDS, RAISED FACE

ANSI CLASS 600 ♦ CARBON AND STAINLESS STEEL

NEWLY DESIGNED... Gauge Taps

STANDARD ON ALL YS 64
MODELS IN SIZES 2" ~ 12"

MODELS: YS 64-CS
(CARBON STEEL)

YS 64-SS
(STAINLESS STEEL)

2" YS 64-SS



FEATURES

SIZE RANGE: 1/2" ~ 12"

♦ NEW DESIGN WITH GAUGE TAPS

TITAN'S YS64 HAS CONVENIENT GAUGE TAPS FURNISHED WITH A PLUG ON BOTH THE INLET AND OUTLET SIDES OF SIZES 2" THROUGH 12". THESE TAPS ALLOW FOR EASY INSTALLATION OF PRESSURE GAUGES TO MONITOR DIFFERENTIAL PRESSURE AND DETERMINE WHEN SCREEN CLEANING IS NECESSARY.

♦ LARGE STRAINING CAPACITY

WITH ITS LARGE BODY AND SIZABLE STRAINING ELEMENT, THE YS64 PROVIDES EXCELLENT OPEN AREA RATIOS THAT ARE TYPICALLY TWO-AND-A-HALF TIMES LARGER THAN THE CORRESPONDING PIPELINE.

♦ PRECISION MACHINED SEATS

PRECISION MACHINED SCREEN SEATS IN BOTH THE BODY AND CAP HELP TO ENSURE ACCURATE POSITIONING OF THE SCREEN DURING REASSEMBLY AFTER CLEANING. ALSO, THE MACHINED BODY SEATS ENABLE FINER FILTRATION BY PREVENTING DEBRIS BYPASS.

♦ SELF-CLEANING CAPABILITY

WITH A TAPPED NPT BLOW-OFF CONNECTION, THIS UNIT CAN BE FITTED WITH A BLOW-DOWN VALVE WHICH FACILITATES CLEANING OF THE STRAINING ELEMENT. PLEASE CONTACT FACTORY FOR MORE INFORMATION.

♦ EPOXY PAINTED

CARBON STEEL UNITS ARE EPOXY PAINTED TO HELP RESIST RUST AND CORROSION. TITAN FCI ALSO OFFERS EPOXY COATING AS AN OPTION FOR THE YS64.

♦ OPTIONAL COVER DESIGNS

TITAN'S YS64 IS AVAILABLE WITH DIFFERENT COVER OPTIONS INCLUDING SWING, CLAMP, AND HINGE TYPE COVERS. PLEASE CONSULT FACTORY FOR MORE INFORMATION ON THESE OPTIONS.

TECHNICAL

PRESSURE/TEMPERATURE RATING
CS - ASTM A216 GR. WCB - CLASS 600

WOG (Non-shock): 1480 PSI @ 100 °F

PRESSURE/TEMPERATURE RATING
SS - ASTM A351 GR. CF8M - CLASS 600

WOG (Non-shock): 1440 PSI @ 100 °F

- The above listed temperatures are theoretical and may vary during actual operating conditions.
- Carbon Steel not recommended for prolonged use above 800 °F.
- Stainless Steel not recommended for prolonged use above 1000 °F.

APPLICATIONS

CARBON STEEL PROPERTIES: CARBON STEEL PERFORMS EXCEPTIONALLY WELL IN HIGH TEMPERATURES, UP TO 800°F IN CONTINUOUS SERVICE. IT PROVIDES HIGH RESISTANCE TO SHOCK, VIBRATION, PIPING STRAINS, AND FIRE AND FREEZING HAZARDS. CARBON STEEL STRAINERS ARE OFTEN USED IN THE OIL AND PETROCHEMICAL INDUSTRIES.

STAINLESS STEEL PROPERTIES: STAINLESS STEEL IS COMMONLY SPECIFIED FOR HIGH TEMPERATURE SERVICE, UP TO 1000°F IN CONTINUOUS SERVICE. STAINLESS STEEL STRAINERS ARE COMMONLY FOUND IN THE CHEMICAL, FOOD, AND PHARMACEUTICAL INDUSTRIES.

The above data represents common market and service applications. No representation or guarantee, expressed or implied, is given due to the numerous variations of concentrations, temperatures and flow conditions that may occur during actual service.

TITAN FLOW CONTROL, INC.
YOUR PIPELINE TO THE FUTURE!

Tel: 910-735-0000 ♦ Fax: 910-738-3848 ♦ titan@titanfci.com ♦ www.titanfci.com
290 Corporate Drive ♦ PO Box 7408 ♦ Lumberton, NC 28358



TITAN FLOW CONTROL, Inc.

290 Corporate Drive
Lumberton, NC 28358
Tel: 910.735.0000

E-mail: titan@titanfci.com
Web: www.titanfci.com
Fax: 910.738.3848

WYE STRAINER
YS 64-CS - (Carbon Steel)
YS 64-SS - (Stainless Steel)
Flanged Ends • Raised Face • Carbon & Stainless Steel

ANSI Class
600

BILL OF MATERIALS (1)

No.	PART	YS 64-CS (3)	YS 64-SS
1	Body	Carbon Steel A216 Gr. WCB	Stainless Steel A351 Gr. CF8M
2	Cover	Carbon Steel A216 Gr. WCB	Stainless Steel A351 Gr. CF8M
3	Straining Element (2)	Stainless Steel	Stainless Steel
4	Gasket (2) (4)	Stainless Steel Spiral Wound	Stainless Steel Spiral Wound
5	Studs	Alloy Steel	Stainless Steel
6	Nuts	Alloy Steel	Stainless Steel
7	NPT Plug Blow-off	Carbon Steel	Stainless Steel
8	NPT Plug Gauge Taps(5)	Carbon Steel	Stainless Steel

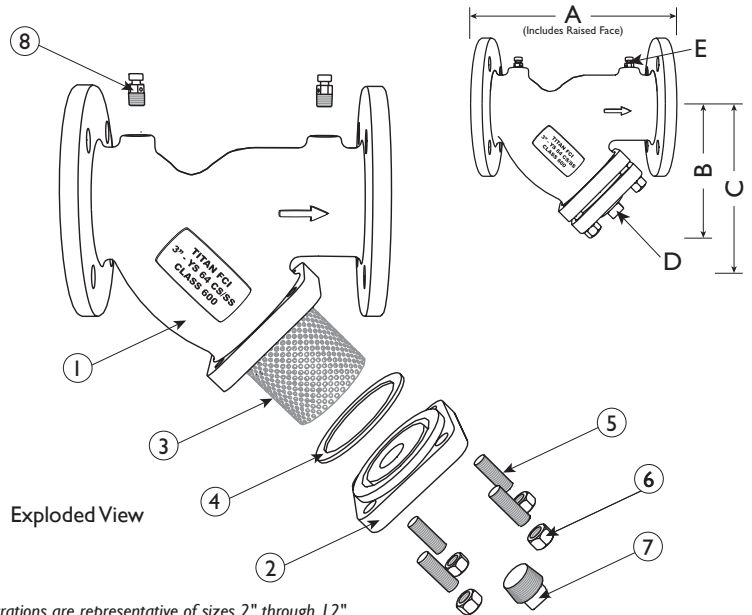

Exploded View

Illustrations are representative of sizes 2" through 12" only. Please ask for certified drawings when required.

1. Bill of Materials represents standard materials. Equivalent or better materials may be substituted at the manufacturer's discretion.
2. Denotes recommended spare parts.
3. Carbon Steel bodies are epoxy painted.
4. A wide range of gasket materials are available; contact factory.
5. Part number 8 (NPT Plug - Gauge Taps) only applies to sizes 2" through 12".

DIMENSIONS AND PERFORMANCE DATA (1)

SIZE	in	1/2	3/4	1	1 1/4	1 1/2	2	2 1/2	3	4	5	6	8	10	12
	mm	15	20	25	32	40	50	65	80	100	125	150	200	250	300
A DIMENSION FACETO FACE (2)	in	6.62	8.31	8.31	10.12	10.25	11.00	12.00	13.50	17.93	22.25	25.62	31.75	37.68	40.00
	mm	169	212	212	258	261	280	305	343	456	566	651	807	958	1016
B DIMENSION CENTER LINE TO BOTTOM	in	3.50	3.75	3.75	5.50	5.50	7.00	8.25	9.25	12.50	15.00	20.00	24.00	28.50	29.31
	mm	89	96	96	140	140	178	210	235	318	381	508	610	724	746
C DIMENSION SCREEN REMOVAL	in	5.00	5.00	5.00	8.00	8.00	10.00	12.50	14.50	19.50	23.00	31.00	38.50	45.50	44.00
	mm	127	127	127	204	204	254	318	369	496	585	788	978	1156	1118
D NPT Plug BLOW-OFF	in	3/8	1/2	1/2	1/2	1/2	1/2	1	1	1 1/2	2	2	2	2	2
	mm	10	15	15	15	15	15	25	25	40	50	50	50	50	50
E NPT Plug GAUGE TAPS	in	N/A	N/A	N/A	N/A	N/A	1/4	1/4	1/4	1/4	1/4	1/4	1/4	1/4	1/4
	mm	N/A	N/A	N/A	N/A	N/A	8	8	8	8	8	8	8	8	8
ASSEMBLED WEIGHT APPROXIMATE	lb	7.5	10.0	13.5	26.0	25.0	32.0	50.0	65.0	125.0	254.0	304.0	526.0	1090.0	1558.0
	kg	3.4	4.5	6.1	11.8	11.3	14.5	22.7	29.5	56.7	115.1	137.9	238.6	493.8	705.9
Flow Coefficient	C _v	C/F	C/F	C/F	C/F	42	70	110	160	260	400	570	950	1600	2200

1. Dimensions and weights are for reference only. When required, request certified drawings.
2. Face to face dimension includes raised face. These values have a tolerance of ±0.06 in (±2.0 mm) for sizes 10" and lower and a tolerance of ±0.12 in (±3.0 mm) for sizes 12" and larger.

PRESSURE - TEMPERATURE RATING

Body Material	A216 Gr. WCB	A351 Gr. CF8M
WOG (Non-shock):	1480 PSI @ 100 °F	1440 PSI @ 100 °F

STANDARD SCREEN SELECTIONS

Size	Liquid	Open Area	Steam	Open Area
1/2" - 4"	1/16 (.0625)	41%	1/32 (.033)	28%
5" - 8"	1/8 (.125)	40%	3/64 (.045)	36%
10" - 12"	1/8 (.125)	40%	30 Mesh Lined	44.8%

REFERENCED STANDARDS & CODES

CODE	DESCRIPTION
ASME/ANSI B16.5	Pipe Flanges and Flanged Fittings
ASME/ANSI B16.34	Flanged, Threaded, and Welding End

PRESSURE - TEMPERATURE RATINGS

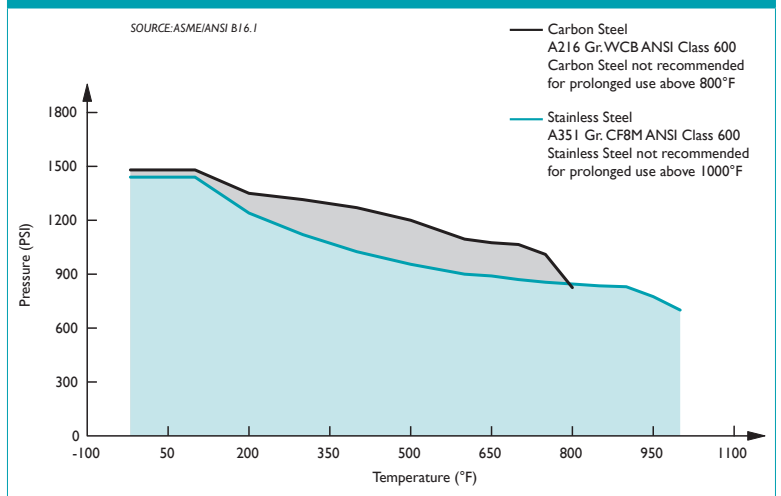

Titan FCI makes every effort to ensure the information presented on our literature accurately reflects exact product specifications. However, as product changes occur, there may be short-term differences between actual product specifications and the information contained within our literature. Titan FCI reserves the right to make design and specification changes to improve our products without prior notification. When required, request certified drawings.



TITAN FLOW CONTROL, INC.

"Y" (WYE) STRAINER ♦ BUTT WELD ENDS

ANSI CLASS 600 ♦ CARBON AND STAINLESS STEEL

MODELS: **YS 65-CS**
(CARBON STEEL)

YS 65-SS
(STAINLESS STEEL)

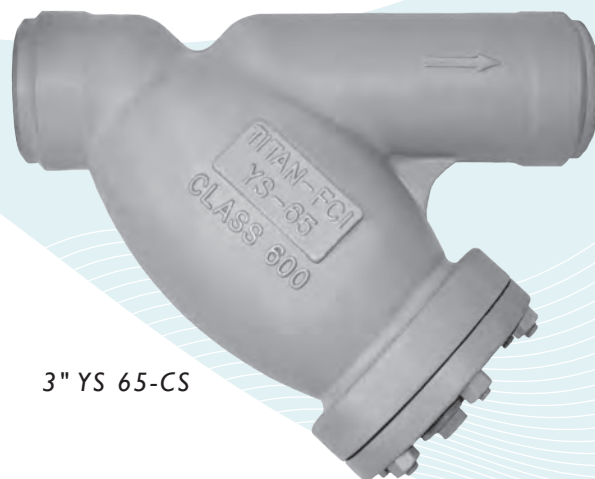

3" YS 65-CS

FEATURES

SIZE RANGE: 1/2" ~ 12"

- ♦ **LARGE STRAINING CAPACITY**
WITH ITS LARGE BODY AND SIZABLE STRAINING ELEMENT, THE YS65 PROVIDES EXCELLENT OPEN AREA RATIOS THAT ARE TYPICALLY TWO-AND-A-HALF TIMES LARGER THAN THE CORRESPONDING PIPELINE.
- ♦ **PRECISION MACHINED SEATS**
PRECISION MACHINED SCREEN SEATS IN BOTH THE BODY AND CAP HELP TO ENSURE ACCURATE POSITIONING OF THE SCREEN DURING REASSEMBLY AFTER CLEANING. ALSO, THE MACHINED BODY SEATS ENABLE FINER FILTRATION BY PREVENTING DEBRIS BYPASS.
- ♦ **ENCAPSULATED "CG" STYLE GASKET**
THE "CG" STYLE COVER GASKET PROVIDES ADDITIONAL RADIAL STRENGTH TO PREVENT GASKET BLOWOUT. IT ALSO ACTS AS A COMPRESSION STOP.
- ♦ **SELF-CLEANING CAPABILITY**
WITH A TAPPED NPT BLOW-OFF CONNECTION, THIS UNIT CAN BE FITTED WITH A BLOW-DOWN VALVE WHICH FACILITATES CLEANING OF THE STRAINING ELEMENT. PLEASE CONTACT FACTORY FOR MORE INFORMATION.
- ♦ **EPOXY PAINTED**
CARBON STEEL UNITS ARE EPOXY PAINTED TO HELP RESIST RUST AND CORROSION. TITAN FCI ALSO OFFERS EPOXY COATING AS AN OPTION FOR THE YS65.
- ♦ **OPTIONAL COVER DESIGNS**
TITAN'S YS65 IS AVAILABLE WITH DIFFERENT COVER OPTIONS INCLUDING SWING, CLAMP, AND HINGE TYPE COVERS. PLEASE CONSULT FACTORY FOR MORE INFORMATION ON THESE OPTIONS.

TECHNICAL

PRESSURE/TEMPERATURE RATING
CS - ASTM A216 GR. WCB - CLASS 600

WOG (Non-shock): 1480 PSI @ 100 °F

PRESSURE/TEMPERATURE RATING
SS - ASTM A351 GR. CF8M - CLASS 600

WOG (Non-shock): 1440 PSI @ 100 °F

- The above listed temperatures are theoretical and may vary during actual operating conditions.
- Carbon Steel not recommended for prolonged use above 800 °F.
- Stainless Steel not recommended for prolonged use above 1000 °F.

APPLICATIONS

CARBON STEEL PROPERTIES: CARBON STEEL PERFORMS EXCEPTIONALLY WELL IN HIGH TEMPERATURES, UP TO 800°F IN CONTINUOUS SERVICE. IT PROVIDES HIGH RESISTANCE TO SHOCK, VIBRATION, PIPING STRAINS, AND FIRE AND FREEZING HAZARDS. CARBON STEEL STRAINERS ARE OFTEN USED IN THE OIL AND PETROCHEMICAL INDUSTRIES.

STAINLESS STEEL PROPERTIES: STAINLESS STEEL IS COMMONLY SPECIFIED FOR HIGH TEMPERATURE SERVICE, UP TO 1000°F IN CONTINUOUS SERVICE. STAINLESS STEEL STRAINERS ARE COMMONLY FOUND IN THE CHEMICAL, FOOD, AND PHARMACEUTICAL INDUSTRIES.

The above data represents common market and service applications. No representation or guarantee, expressed or implied, is given due to the numerous variations of concentrations, temperatures and flow conditions that may occur during actual service.

TITAN FLOW CONTROL, INC.

YOUR PIPELINE TO THE FUTURE!

Tel: 910-735-0000 ♦ Fax: 910-738-3848 ♦ titan@titanfci.com ♦ www.titanfci.com
290 Corporate Drive ♦ PO Box 7408 ♦ Lumberton, NC 28358



TITAN FLOW CONTROL, Inc.
 290 Corporate Drive
 Lumberton, NC 28358
 Tel: 910.735.0000
 E-mail: titan@titanfci.com
 Web: www.titanfci.com
 Fax: 910.738.3848

WYE STRAINER
YS 65-CS - (Carbon Steel)
YS 65-SS - (Stainless Steel)
Butt Welded Ends • Carbon & Stainless Steel

ANSI Class
 600

BILL OF MATERIALS ⁽¹⁾

No.	PART	YS 65-CS ⁽⁵⁾	YS 65-SS
1	Body ⁽²⁾	Carbon Steel A216 Gr. WCB	Stainless Steel A351 Gr. CF8M
2	Cover	Carbon Steel A216 Gr. WCB	Stainless Steel A351 Gr. CF8M
3	Straining Element ⁽³⁾	Stainless Steel	Stainless Steel
4	Gasket ^{(3) (4)}	Stainless Steel "CG" Style	Stainless Steel "CG" Style
5	Studs	Alloy Steel	Stainless Steel
6	Nuts	Carbon Steel	Stainless Steel
7	NPT Plug Blow-off	Carbon Steel	Stainless Steel

- Bill of Materials represents standard materials. Equivalent or better materials may be substituted at the manufacturer's discretion.
- Available in additional body materials, such as LCB, WC6, WC9, 316L, Alloy 20, and Monel.
- Denotes recommended spare parts.
- The cover gasket is encapsulated in a machined recessed seat. A wide range of gasket materials are available; contact factory.
- Carbon Steel bodies are epoxy painted.

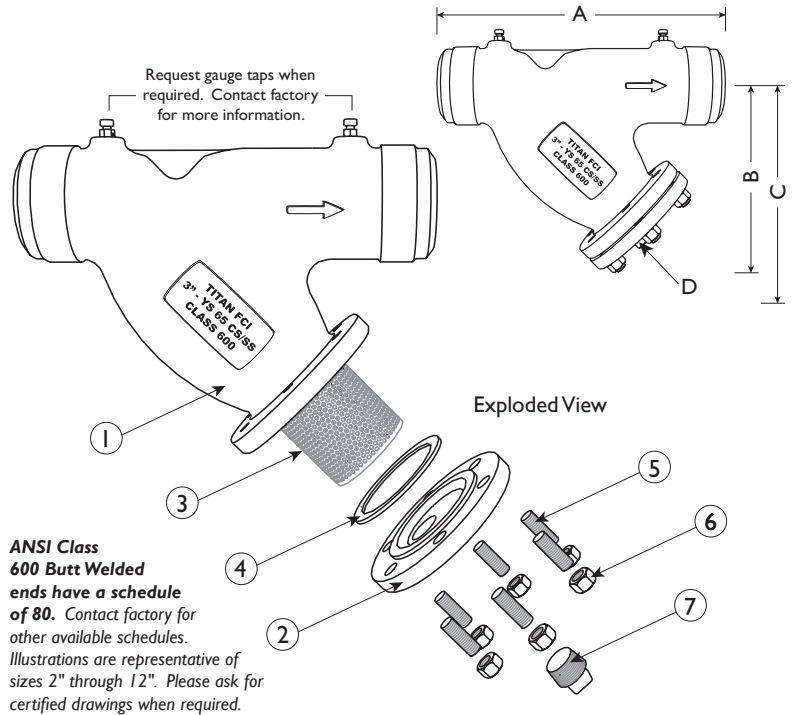

DIMENSIONS AND PERFORMANCE DATA ⁽¹⁾

SIZE	in	1/2	3/4	1	1 1/4	1 1/2	2	2 1/2	3	4	5	6	8	10	12
	mm	15	20	25	32	40	50	65	80	100	125	150	200	250	300
A DIMENSION FACETO FACE ⁽²⁾	in	6.62	8.31	8.31	10.12	10.25	11.0	12.00	13.50	17.938	22.25	25.62	31.75	37.68	45.50
	mm	168	211	211	257	260	279	305	343	456	565	651	806	957	1156
B DIMENSION CENTER LINE TO BOTTOM	in	3.50	3.75	3.75	5.5	5.5	7.0	8.25	9.25	12.5	15.00	20.00	24.00	28.50	34.50
	mm	89	96	96	140	140	178	210	235	318	381	508	610	724	876
C DIMENSION SCREEN REMOVAL	in	5.00	5.00	5.00	8.00	8.00	10.00	12.50	14.50	19.5	23.00	31.00	38.50	45.50	52.00
	mm	127	127	127	203	203	254	318	368	495	584	787	978	1156	1321
D NPT Plug BLOW-OFF	in	3/8	1/2	1/2	1/2	1/2	1/2	1	1	1 1/2	2	2	2	2	2
	mm	10	15	15	15	15	15	25	25	40	50	50	50	50	50
ASSEMBLED WEIGHT APPROXIMATE	lb	C/F	C/F	C/F	C/F	C/F	15	30	33	77	C/F	217	386	C/F	C/F
	kg	C/F	C/F	C/F	C/F	C/F	6.8	13.6	15.0	34.9	C/F	98.4	175	C/F	C/F
Flow Coefficient	C _v	9	18	30	C/F	42	70	110	160	260	400	570	950	1600	2200

- Dimensions and weights are for reference only. When required, request certified drawings.
- Face to face values have a tolerance of ±0.06 in (±2.0 mm) for sizes 10" and lower and a tolerance of ±0.12 in (±3.0 mm) for sizes 12" and larger.

REFERENCED STANDARDS & CODES

CODE	DESCRIPTION
ASME/ANSI B16.25	Buttwelding Ends
ASME/ANSI B16.34	Flanged, Threaded, and Welding End

STANDARD SCREEN SELECTIONS

Size	Liquid	Open Area	Steam	Open Area
1/2" - 4"	1/16 (.0625)	41%	1/32 (.033)	28%
5" - 8"	1/8 (.125)	40%	3/64 (.045)	36%
10" - 12"	1/8 (.125)	40%	30 Mesh Lined	44.8%

PRESSURE - TEMPERATURE RATING

Body Material	A216 Gr. WCB	A351 Gr. CF8M
WOG (Non-shock):	1480 PSI @ 100 °F	1440 PSI @ 100 °F

PRESSURE - TEMPERATURE RATINGS

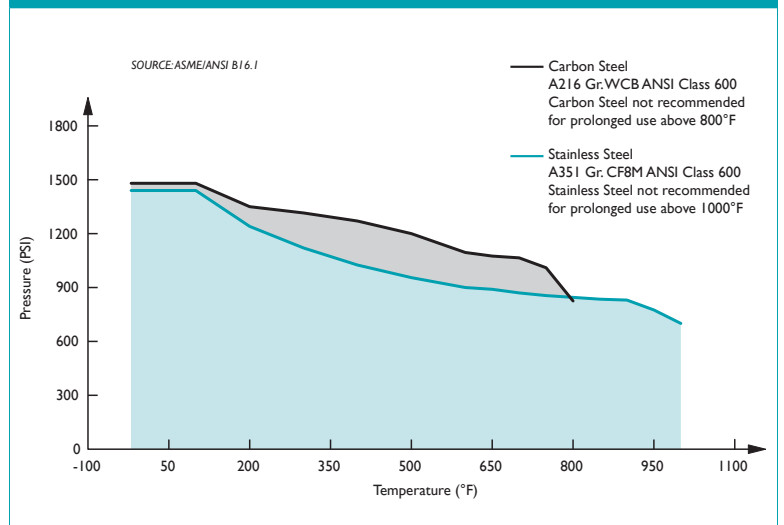

Titan FCI makes every effort to ensure the information presented on our literature accurately reflects exact product specifications. However, as product changes occur, there may be short-term differences between actual product specifications and the information contained within our literature. Titan FCI reserves the right to make design and specification changes to improve our products without prior notification. When required, request certified drawings.



TITAN FLOW CONTROL, INC.

"Y" (WYE) STRAINER ♦ BUTT WELD ENDS

ANSI CLASS 900 ♦ CARBON AND STAINLESS STEEL

MODELS: YS 67-CS

(CARBON STEEL)

YS 67-SS

(STAINLESS STEEL)

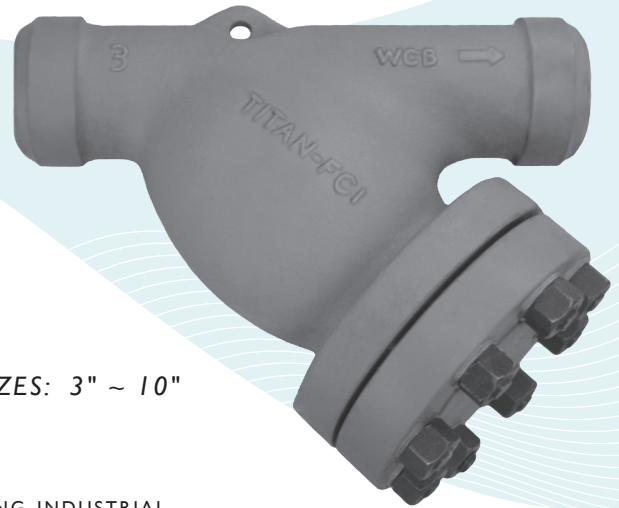

SIZES: 3" ~ 10"

FEATURES

- ♦ **RUGGED - HIGH QUALITY DESIGN**
TITAN'S YS67 IS IDEAL FOR PETROCHEMICAL AND OTHER DEMANDING INDUSTRIAL APPLICATIONS THAT HAVE HIGHER PRESSURE AND TEMPERATURE REQUIREMENTS. THIS UNIT EMPLOYS HEAVY GAUGE, REINFORCED SCREENS TO PREVENT DAMAGE TO THE STRAINING ELEMENT. BOLT HOLES ARE ALSO BACK OR SPOT FACED.
- ♦ **LARGE STRAINING CAPACITY**
WITH ITS LARGE BODY AND SIZABLE STRAINING ELEMENT, THE YS67 PROVIDES EXCELLENT OPEN AREA RATIOS THAT ARE TYPICALLY TWO-AND-A-HALF TIMES LARGER THAN THE CORRESPONDING PIPELINE.
- ♦ **PRECISION MACHINED SEATS**
PRECISION MACHINED SCREEN SEATS IN BOTH THE BODY AND CAP HELP TO ENSURE ACCURATE POSITIONING OF THE SCREEN DURING REASSEMBLY AFTER CLEANING. ALSO, THE MACHINED BODY SEATS ENABLE FINER FILTRATION BY PREVENTING DEBRIS BYPASS.
- ♦ **ENCAPSULATED "CG" STYLE GASKET**
THE "CG" STYLE COVER GASKET PROVIDES ADDITIONAL RADIAL STRENGTH TO PREVENT GASKET BLOWOUT. IT ALSO ACTS AS A COMPRESSION STOP.
- ♦ **SELF-CLEANING CAPABILITY**
WITH THE OPTIONAL SOCKET WELD BLOW-OFF CONNECTION, THIS UNIT CAN BE FITTED WITH A BLOW-DOWN VALVE WHICH FACILITATES CLEANING OF THE STRAINING ELEMENT. PLEASE CONTACT FACTORY FOR MORE INFORMATION.
- ♦ **EPOXY PAINTED**
CARBON UNITS ARE EPOXY PAINTED TO HELP RESIST RUST AND CORROSION. TITAN FCI ALSO OFFERS EPOXY COATING. PLEASE CONTACT FACTORY FOR MORE INFORMATION.

TECHNICAL

PRESSURE/TEMPERATURE RATING
CS - ASTM A216 GR. WCB - CLASS 900

WOG (Non-shock): 2220 PSI @ 100 °F

PRESSURE/TEMPERATURE RATING
SS - ASTM A351 GR. CF8M - CLASS 900

WOG (Non-shock): 2160 PSI @ 100 °F

- The above listed temperatures are theoretical and may vary during actual operating conditions.
- Carbon Steel not recommended for prolonged use above 800 °F.
- Stainless Steel not recommended for prolonged use above 1000 °F.

APPLICATIONS

CARBON STEEL PROPERTIES: CARBON STEEL PERFORMS EXCEPTIONALLY WELL IN HIGH TEMPERATURES, UP TO 800°F IN CONTINUOUS SERVICE. IT PROVIDES HIGH RESISTANCE TO SHOCK, VIBRATION, PIPING STRAINS, AND FIRE AND FREEZING HAZARDS. CARBON STEEL STRAINERS ARE OFTEN USED IN THE OIL AND PETROCHEMICAL INDUSTRIES.

STAINLESS STEEL PROPERTIES: STAINLESS STEEL IS COMMONLY SPECIFIED FOR HIGH TEMPERATURE SERVICE, UP TO 1000°F IN CONTINUOUS SERVICE. STAINLESS STEEL STRAINERS ARE COMMONLY FOUND IN THE CHEMICAL, FOOD, AND PHARMACEUTICAL INDUSTRIES.

The above data represents common market and service applications. No representation or guarantee, expressed or implied, is given due to the numerous variations of concentrations, temperatures and flow conditions that may occur during actual service.

TITAN FLOW CONTROL, INC.
YOUR PIPELINE TO THE FUTURE!

Tel: 910-735-0000 ♦ Fax: 910-738-3848 ♦ titan@titanfci.com ♦ www.titanfci.com



TITAN FLOW CONTROL, Inc.

290 Corporate Drive
Lumberton, NC 28358
Tel: 910.735.0000

E-mail: titan@titanfci.com
Web: www.titanfci.com
Fax: 910.738.3848

WYE STRAINER
YS 67-CS - (Carbon Steel)
YS 67-SS - (Stainless Steel)
Butt Weld Ends • Carbon & Stainless Steel

ANSI Class
900

BILL OF MATERIALS ⁽¹⁾

No.	PART	YS 67-CS ⁽²⁾	YS 67-SS
1	Body	Carbon Steel A216 Gr. WCB	Stainless Steel A351 Gr. CF8M Type 316
2	Cover	Carbon Steel A216 Gr. WCB	Stainless Steel A351 Gr. CF8M Type 316
3	Straining Element ⁽³⁾	Stainless Steel	Stainless Steel
4	Gasket ⁽³⁾	Stainless Steel CG Style	Stainless Steel CG Style
5	Studs	Alloy Steel	Alloy Steel
6	Nuts	Alloy Steel	Alloy Steel

1. Bill of Materials represents standard materials. Equivalent or better materials may be substituted at the manufacturer's discretion.
2. Carbon Steel bodies are epoxy painted.
3. Denotes recommended spare parts.

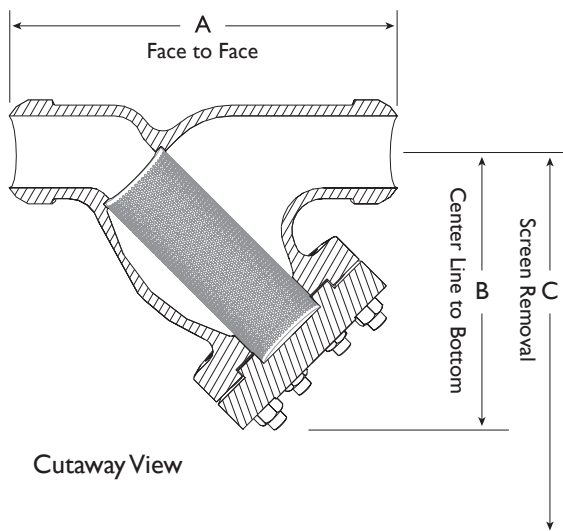
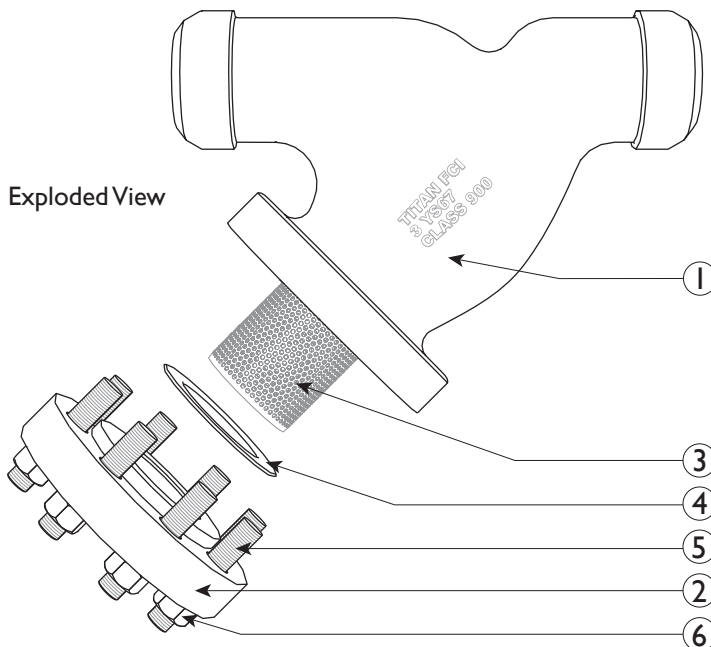

ANSI Class 900 Butt Welded ends have a schedule of 160.

Illustrations are representative of sizes 3" through 8".
Please ask for certified drawings when required.

REFERENCED STANDARDS & CODES

CODE	DESCRIPTION
ASME/ANSI B16.25	Butt Welding Ends
ASME/ANSI B16.34	Flanged, Threaded, and Welding End

PRESSURE - TEMPERATURE RATING

Body Material	A216 Gr. WCB	A351 Gr. CF8M
WOG (Non-shock):	2220 PSI @ 100 °F	2160 PSI @ 100 °F

STANDARD SCREEN SELECTIONS

Size	Liquid	Open Area	Steam	Open Area
3" ~ 4"	1/16 (.0625)	41%	1/32 (.033)	28%
8"	1/8 (.125)	40%	3/64 (.045)	36%

DIMENSIONS AND PERFORMANCE DATA ⁽¹⁾

SIZE	in	3	4	6	8	10
	mm	80	100	150	200	255
A DIMENSION FACE TO FACE	in	15.50	18.13	21.50	25.0	37.0
	mm	394	461	546	635	940
B DIMENSION CENTER LINE TO BOTTOM	in	11.46	14.45	19.0	20.0	27.5
	mm	291	367	483	508	699
C DIMENSION SCREEN REMOVAL	in	17.50	18.50	26.0	28.5	32.5
	mm	445	470	660	724	826
APPROXIMATE ASSEMBLED WEIGHT	lb	80.0	156.0	C/F	468.0	C/F
	kg	36.2	70.8	C/F	212.3	C/F
Flow Coefficient	C _v	140	180	450	650	930

1. Dimensions, weights, and flow coefficients are for reference only. When required, request certified drawings.

PRESSURE - TEMPERATURE RATINGS

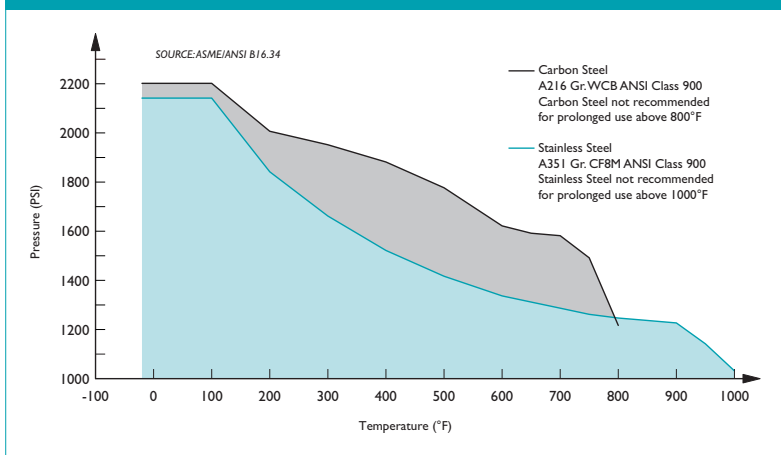

Additional Design & Technical Notes:

- Butt weld ends are X-rayed to ensure high quality.
- An optional socket weld blow-off is available. Please contact factory.
- NPT blow-offs are not recommended for ANSI Class 900 strainers.
- Bodies are also available in high temperature steel A217 Gr. WC6 and WC9. Please contact factory for price and delivery.

Titan FCI makes every effort to ensure the information presented on our literature accurately reflects exact product specifications. However, as product changes occur, there may be short-term differences between actual product specifications and the information contained within our literature. Titan FCI reserves the right to make design and specification changes to improve our products without prior notification. When required, request certified drawings.



TITAN FLOW CONTROL, INC.

"Y" (WYE) STRAINER ♦ FLANGED ENDS, RAISED FACE

ANSI CLASS 1500 ♦ CARBON AND STAINLESS STEEL

MODELS: YS 68-CS

(CARBON STEEL)

YS 68-SS

(STAINLESS STEEL)

SIZES: 2" ~ 8"

FEATURES

◇ RUGGED - HIGH QUALITY DESIGN

TITAN'S YS68 IS IDEAL FOR PETROCHEMICAL AND OTHER DEMANDING INDUSTRIAL APPLICATIONS THAT HAVE HIGHER PRESSURE AND TEMPERATURE REQUIREMENTS. THIS UNIT EMPLOYS HEAVY GAUGE, REINFORCED SCREENS TO PREVENT DAMAGE TO THE STRAINING ELEMENT. BOLT HOLES ARE ALSO BACK OR SPOT FACED AND THE OUTSIDE DIAMETERS OF THE FLANGES ARE MACHINED FOR PRECISION.

◇ LARGE STRAINING CAPACITY

WITH ITS LARGE BODY AND SIZABLE STRAINING ELEMENT, THE YS68 PROVIDES EXCELLENT OPEN AREA RATIOS THAT ARE TYPICALLY TWO-AND-A-HALF TIMES LARGER THAN THE CORRESPONDING PIPELINE.

◇ PRECISION MACHINED SEATS

PRECISION MACHINED SCREEN SEATS IN BOTH THE BODY AND CAP HELP TO ENSURE ACCURATE POSITIONING OF THE SCREEN DURING REASSEMBLY AFTER CLEANING. ALSO, THE MACHINED BODY SEATS ENABLE FINER FILTRATION BY PREVENTING DEBRIS BYPASS.

◇ ENCAPSULATED "CG" STYLE GASKET

THE "CG" STYLE COVER GASKET PROVIDES ADDITIONAL RADIAL STRENGTH TO PREVENT GASKET BLOWOUT. IT ALSO ACTS AS A COMPRESSION STOP.

◇ SELF-CLEANING CAPABILITY

WITH THE OPTIONAL SOCKET WELD BLOW-OFF CONNECTION, THIS UNIT CAN BE FITTED WITH A BLOW-DOWN VALVE WHICH FACILITATES CLEANING OF THE STRAINING ELEMENT. PLEASE CONTACT FACTORY FOR MORE INFORMATION.

◇ EPOXY PAINTED

CARBON UNITS ARE EPOXY PAINTED TO HELP RESIST RUST AND CORROSION. TITAN FCI ALSO OFFERS EPOXY COATING. PLEASE CONTACT FACTORY FOR MORE INFORMATION.

"Ideal for
High-Pressure
Applications"

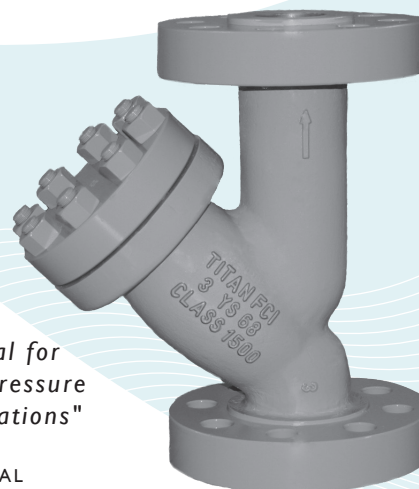

TECHNICAL

PRESSURE/TEMPERATURE RATING
CS - ASTM A216 GR. WCB - CLASS 1500

WOG (Non-shock): 3705 PSI @ 100 °F

PRESSURE/TEMPERATURE RATING
SS - ASTM A351 GR. CF8M - CLASS 1500

WOG (Non-shock): 3600 PSI @ 100 °F

- The above listed temperatures are theoretical and may vary during actual operating conditions.
- Carbon Steel not recommended for prolonged use above 800 °F.
- Stainless Steel not recommended for prolonged use above 1000 °F.

APPLICATIONS

CARBON STEEL PROPERTIES: CARBON STEEL PERFORMS EXCEPTIONALLY WELL IN HIGH TEMPERATURES, UP TO 800°F IN CONTINUOUS SERVICE. IT PROVIDES HIGH RESISTANCE TO SHOCK, VIBRATION, PIPING STRAINS, AND FIRE AND FREEZING HAZARDS. CARBON STEEL STRAINERS ARE OFTEN USED IN THE OIL AND PETROCHEMICAL INDUSTRIES

STAINLESS STEEL PROPERTIES: STAINLESS STEEL IS COMMONLY SPECIFIED FOR HIGH TEMPERATURE SERVICE, UP TO 1000°F IN CONTINUOUS SERVICE. STAINLESS STEEL STRAINERS ARE COMMONLY FOUND IN THE CHEMICAL, FOOD, AND PHARMACEUTICAL INDUSTRIES.

The above data represents common market and service applications. No representation or guarantee, expressed or implied, is given due to the numerous variations of concentrations, temperatures and flow conditions that may occur during actual service.

TITAN FLOW CONTROL, INC.
YOUR PIPELINE TO THE FUTURE!

Tel: 910-735-0000 ♦ Fax: 910-738-3848 ♦ titan@titanfci.com ♦ www.titanfci.com
290 Corporate Drive ♦ PO Box 7408 ♦ Lumberton, NC 28358



TITAN FLOW CONTROL, Inc.

290 Corporate Drive
Lumberton, NC 28358
Tel: 910.735.0000

E-mail: titan@titanfci.com
Web: www.titanfci.com
Fax: 910.738.3848

WYE STRAINER
YS 68-CS - (Carbon Steel)
YS 68-SS - (Stainless Steel)

ANSI Class
1500

Flanged Ends • Raised Face • Carbon & Stainless Steel

BILL OF MATERIALS ⁽¹⁾

No.	PART	YS 68-CS ⁽³⁾	YS 68-SS
1	Body	Carbon Steel A216 Gr. WCB	Stainless Steel A351 Gr. CF8M
2	Cover	Carbon Steel A216 Gr. WCB	Stainless Steel A351 Gr. CF8M
3	Straining Element ⁽²⁾	Stainless Steel	Stainless Steel
4	Gasket ⁽²⁾	Stainless Steel CG Style	Stainless Steel CG Style
5	Studs	Alloy Steel	Alloy Steel
6	Nuts	Alloy Steel	Alloy Steel

1. Bill of Materials represents standard materials. Equivalent or better materials may be substituted at the manufacturer's discretion.
2. Denotes recommended spare parts.
3. Carbon Steel bodies are epoxy painted.

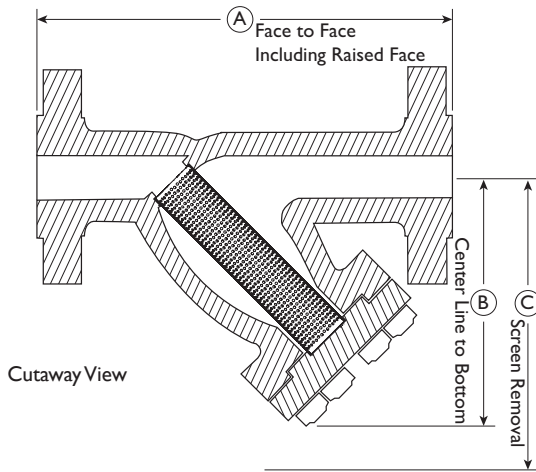

Illustrations are representative of sizes 2" through 8".
Please ask for certified drawings when required.

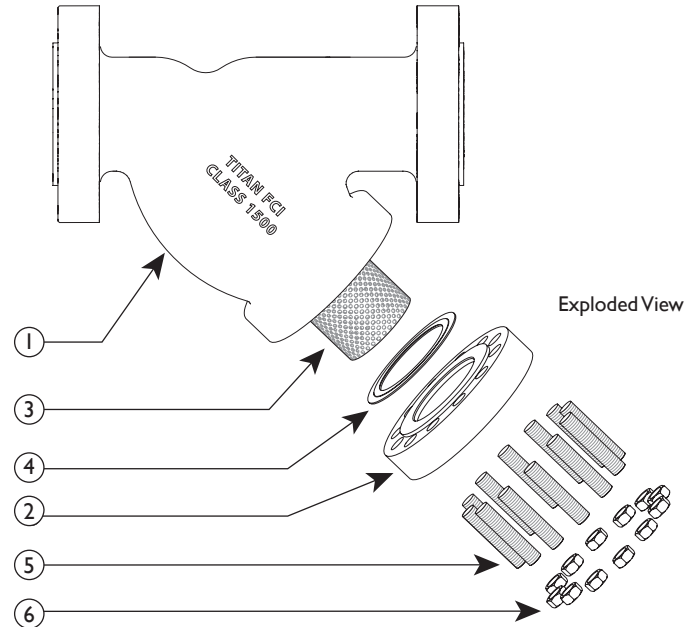

DIMENSIONS AND PERFORMANCE DATA ⁽¹⁾

SIZE	in	2	2 1/2	3	4	6	8
	mm	50	65	80	100	150	200
A DIMENSION FACE TO FACE ⁽²⁾	in	16.5	C/F	18.0	22.5	32.5	36.0
	mm	419	C/F	457	572	826	914
B DIMENSION CENTER LINE TO BOTTOM	in	9.25	C/F	12.0	15.37	20.0	23.68
	mm	235	C/F	305	391	508	605
C DIMENSION SCREEN REMOVAL	in	11.0	C/F	16.5	21.0	27.0	32.0
	mm	279	C/F	419	533	686	813
APPROXIMATE ASSEMBLED WEIGHT	lb	91	C/F	175	316	766	1575
	kg	41	C/F	79	143	347	714
Flow Coefficient	C _v	60	C/F	140	180	450	650

1. Dimensions and weights are for reference only. When required, request certified drawings.
2. Face to face values have a tolerance of ±0.06 in (±2.0 mm) for sizes 10" and lower.
3. Contact factory before ordering a 2-1/2" YS-68 to get dimensions and performance data.

REFERENCED STANDARDS & CODES

CODE	DESCRIPTION
ASME/ANSI B16.5	Pipe Flanges and Flanged Fittings
ASME/ANSI B16.34	Flanged, Threaded, and Welding End

STANDARD SCREEN SELECTIONS

Size	Liquid	Open Area	Steam	Open Area
2" ~ 4"	1/16 (.0625)	41%	1/32 (.033)	28%
5" ~ 8"	1/8 (.125)	40%	3/64 (.045)	36%

Additional Design & Technical Notes:

- Ring Type Joints (RTJ) are available. Please contact factory.
- An optional socket weld blow-off is available. Please contact factory.
- NPT blow-offs are not recommended for ANSI Class 1500 strainers.
- Bodies are also available in high temperature steel A217 Gr. WC6 and WC9. Please contact factory.

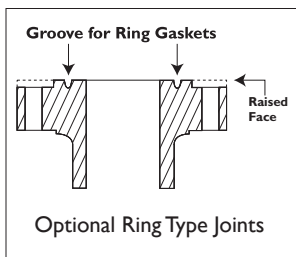

PRESSURE - TEMPERATURE RATINGS

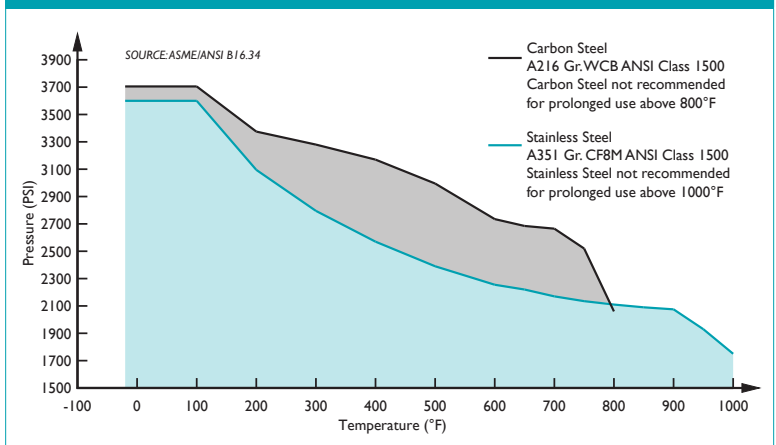

PRESSURE - TEMPERATURE RATING

Body Material	A216 Gr. WCB	A351 Gr. CF8M
WOG (Non-shock):	3705 PSI @ 100 °F	3600 PSI @ 100 °F

Titan FCI makes every effort to ensure the information presented on our literature accurately reflects exact product specifications. However, as product changes occur, there may be short-term differences between actual product specifications and the information contained within our literature. Titan FCI reserves the right to make design and specification changes to improve our products without prior notification. When required, request certified drawings.



TITAN FLOW CONTROL, INC.

"Y" (WYE) STRAINER ♦ BUTT WELD ENDS

ANSI CLASS 1500 ♦ CARBON AND STAINLESS STEEL

MODELS: **YS 69-CS**

(CARBON STEEL)

YS 69-SS

(STAINLESS STEEL)

SIZES: 2" ~ 10"

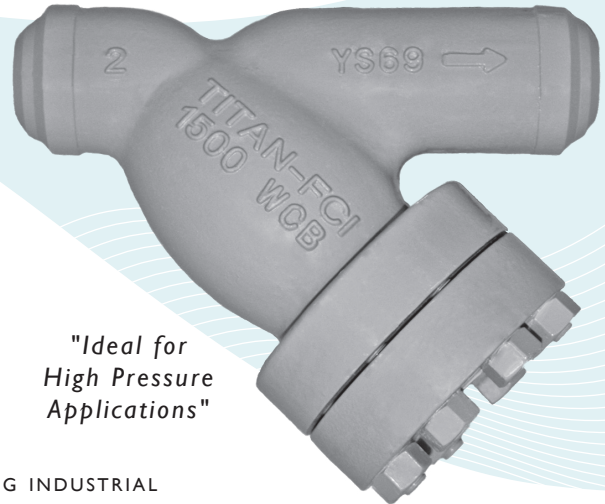

"Ideal for
High Pressure
Applications"

FEATURES

- ♦ **RUGGED - HIGH QUALITY DESIGN**
TITAN'S YS69 IS IDEAL FOR PETROCHEMICAL AND OTHER DEMANDING INDUSTRIAL APPLICATIONS THAT HAVE HIGHER PRESSURE AND TEMPERATURE REQUIREMENTS. THIS UNIT EMPLOYS HEAVY GAUGE, REINFORCED SCREENS TO PREVENT DAMAGE TO THE STRAINING ELEMENT. BOLT HOLES ARE ALSO BACK OR SPOT FACED.
- ♦ **LARGE STRAINING CAPACITY**
WITH ITS LARGE BODY AND SIZABLE STRAINING ELEMENT, THE YS69 PROVIDES EXCELLENT OPEN AREA RATIOS THAT ARE TYPICALLY TWO-AND-A-HALF TIMES LARGER THAN THE CORRESPONDING PIPELINE.
- ♦ **PRECISION MACHINED SEATS**
PRECISION MACHINED SCREEN SEATS IN BOTH THE BODY AND CAP HELP TO ENSURE ACCURATE POSITIONING OF THE SCREEN DURING REASSEMBLY AFTER CLEANING. ALSO, THE MACHINED BODY SEATS ENABLE FINER FILTRATION BY PREVENTING DEBRIS BYPASS.
- ♦ **ENCAPSULATED "CG" STYLE GASKET**
THE "CG" STYLE COVER GASKET PROVIDES ADDITIONAL RADIAL STRENGTH TO PREVENT GASKET BLOWOUT. IT ALSO ACTS AS A COMPRESSION STOP.
- ♦ **SELF-CLEANING CAPABILITY**
WITH THE OPTIONAL SOCKET WELD BLOW-OFF CONNECTION, THIS UNIT CAN BE FITTED WITH A BLOW-DOWN VALVE WHICH FACILITATES CLEANING OF THE STRAINING ELEMENT. PLEASE CONTACT FACTORY FOR MORE INFORMATION.
- ♦ **EPOXY PAINTED**
CARBON UNITS ARE EPOXY PAINTED TO HELP RESIST RUST AND CORROSION. TITAN FCI ALSO OFFERS EPOXY COATING. PLEASE CONTACT FACTORY FOR MORE INFORMATION.

TECHNICAL

PRESSURE/TEMPERATURE RATING
CS - ASTM A216 GR.WCB - CLASS 1500

WOG (Non-shock): 3705 PSI @ 100 °F

PRESSURE/TEMPERATURE RATING
SS - ASTM A351 GR. CF8M - CLASS 1500

WOG (Non-shock): 3600 PSI @ 100 °F

- The above listed temperatures are theoretical and may vary during actual operating conditions.
- Carbon Steel not recommended for prolonged use above 800 °F.
- Stainless Steel not recommended for prolonged use above 1000 °F.

APPLICATIONS

CARBON STEEL PROPERTIES: CARBON STEEL PERFORMS EXCEPTIONALLY WELL IN HIGH TEMPERATURES, UP TO 800°F IN CONTINUOUS SERVICE. IT PROVIDES HIGH RESISTANCE TO SHOCK, VIBRATION, PIPING STRAINS, AND FIRE AND FREEZING HAZARDS. CARBON STEEL STRAINERS ARE OFTEN USED IN THE OIL AND PETROCHEMICAL INDUSTRIES.

STAINLESS STEEL PROPERTIES: STAINLESS STEEL IS COMMONLY SPECIFIED FOR HIGH TEMPERATURE SERVICE, UP TO 1000°F IN CONTINUOUS SERVICE. STAINLESS STEEL STRAINERS ARE COMMONLY FOUND IN THE CHEMICAL, FOOD, AND PHARMACEUTICAL INDUSTRIES.

The above data represents common market and service applications. No representation or guarantee, expressed or implied, is given due to the numerous variations of concentrations, temperatures and flow conditions that may occur during actual service.

TITAN FLOW CONTROL, INC.
YOUR PIPELINE TO THE FUTURE!

Tel: 910-735-0000 ♦ Fax: 910-738-3848 ♦ titan@titanfci.com ♦ www.titanfci.com
290 Corporate Drive ♦ PO Box 7408 ♦ Lumberton, NC 28358



TITAN FLOW CONTROL, Inc.

290 Corporate Drive
Lumberton, NC 28358
Tel: 910.735.0000

E-mail: titan@titanfci.com
Web: www.titanfci.com
Fax: 910.738.3848

WYE STRAINER
YS 69-CS - (Carbon Steel)
YS 69-SS - (Stainless Steel)
Butt Weld Ends • Carbon & Stainless Steel

ANSI Class
1500

BILL OF MATERIALS (1)

No.	PART	YS 69-CS (3)	YS 69-SS
1	Body	Carbon Steel A216 Gr. WCB	Stainless Steel A351 Gr. CF8M
2	Cover	Carbon Steel A216 Gr. WCB	Stainless Steel A351 Gr. CF8M
3	Straining Element (2)	Stainless Steel	Stainless Steel
4	Gasket (2)	Stainless Steel CG Style	Stainless Steel CG Style
5	Studs	Alloy Steel	Alloy Steel
6	Nuts	Alloy Steel	Alloy Steel

1. Bill of Materials represents standard materials. Equivalent or better materials may be substituted at the manufacturer's discretion.
2. Denotes recommended spare parts.
3. Carbon Steel bodies are epoxy painted.

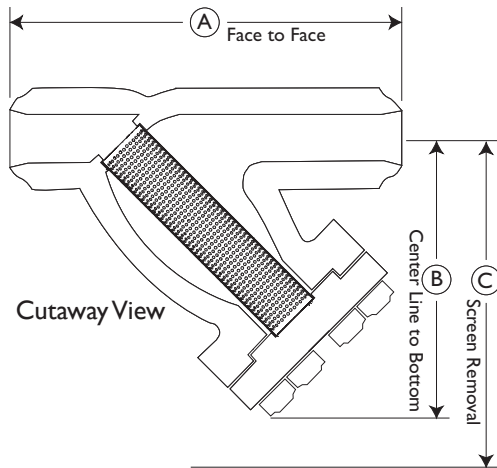
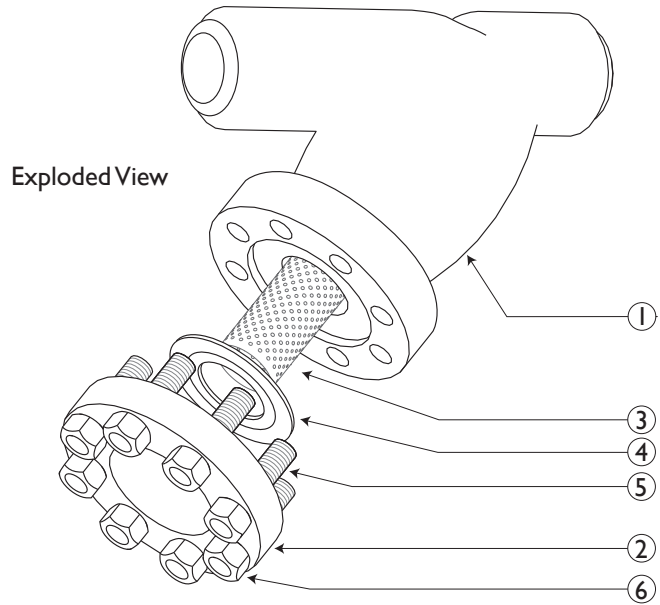

ANSI Class 1500 Butt Welded ends have a schedule of 160.
Illustrations are representative of sizes 2" through 10".
Please ask for certified drawings when required.

DIMENSIONS AND PERFORMANCE DATA (1)

SIZE	in	2	2 1/2	3	4	6	8	10
	mm	50	65	80	100	150	200	250
A DIMENSION FACE TO FACE	in	12.0	18.125	18.125	18.125	23.75	30.125	40.0
	mm	305	460	460	460	603	762	1016
B DIMENSION CENTER LINE TO BOTTOM	in	9.25	12.0	12.0	15.375	20.0	22.75	31.82
	mm	235	305	305	391	508	578	808
C DIMENSION SCREEN REMOVAL	in	11.0	16.5	16.5	21.0	27.0	30.0	41.0
	mm	279	419	419	533	686	762	1041
APPROXIMATE ASSEMBLED WEIGHT	lb	46	100	100	194	460	876	1650
	kg	21	45	45	88	209	397	748
Flow Coefficient	C _v	60	140	140	180	450	650	930

1. Dimensions, weights, and flow coefficients are for reference only. When required, request certified drawings.

PRESSURE - TEMPERATURE RATINGS

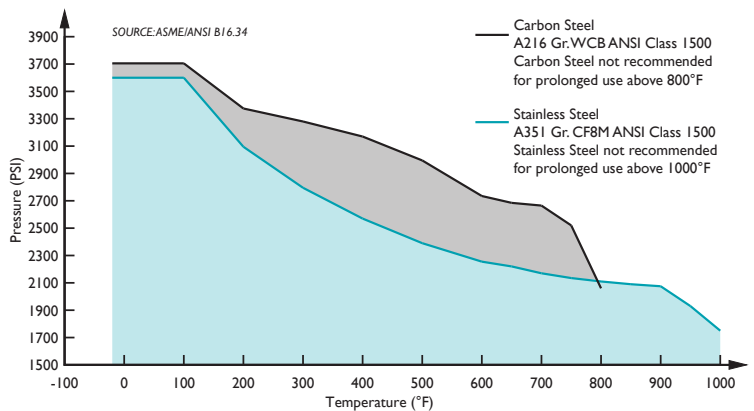

REFERENCED STANDARDS & CODES

CODE	DESCRIPTION
ASME/ANSI B16.25	Butt Welding Ends
ASME/ANSI B16.34	Flanged, Threaded, and Welding End

PRESSURE - TEMPERATURE RATING

Body Material	A216 Gr. WCB	A351 Gr. CF8M
WOG (Non-shock):	3705 PSI @ 100 °F	3600 PSI @ 100 °F

STANDARD SCREEN SELECTIONS

Size	Liquid	Open Area	Steam	Open Area
2" ~ 4"	1/16 (.0625)	41%	1/32 (.033)	28%
5" ~ 8"	1/8 (.125)	40%	3/64 (.045)	36%
10"	1/8 (.125)	40%	30 Mesh Lined	44.8%

Additional Design & Technical Notes:

- Butt weld ends are X-rayed to ensure high quality.
- An optional socket weld blow-off is available. Please contact factory.
- NPT blow-offs are not recommended for ANSI Class 1500 strainers.
- Bodies are also available in high temperature steel A217 Gr. WC6 and WC9. Please contact factory for price and delivery.

Titan FCI makes every effort to ensure the information presented on our literature accurately reflects exact product specifications. However, as product changes occur, there may be short-term differences between actual product specifications and the information contained within our literature. Titan FCI reserves the right to make design and specification changes to improve our products without prior notification. When required, request certified drawings.



TITAN FLOW CONTROL, INC.

"Y" (WYE) STRAINER ♦ FLANGED ENDS, RING TYPE JOINT

ANSI CLASS 2500 ♦ CARBON AND STAINLESS STEEL

MODELS: YS 70-CS

(CARBON STEEL)

YS 70-SS

(STAINLESS STEEL)

SIZES: 2" ~ 8"

"Ideal for
High Pressure
Applications"

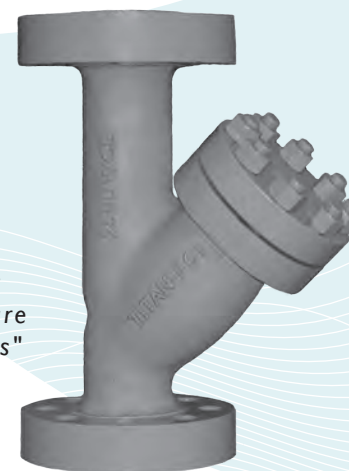

FEATURES

♦ RUGGED - HIGH QUALITY DESIGN

TITAN'S YS70 IS IDEAL FOR POWER GENERATION AND OTHER DEMANDING INDUSTRIAL APPLICATIONS THAT HAVE HIGHER PRESSURE AND TEMPERATURE REQUIREMENTS. THIS UNIT EMPLOYS HEAVY GAUGE, REINFORCED SCREENS TO PREVENT DAMAGE TO THE STRAINING ELEMENT. BOLT HOLES ARE BACK OR SPOT FACED AND THE OUTSIDE DIAMETERS OF THE FLANGES ARE MACHINED FOR PRECISION.

♦ LARGE STRAINING CAPACITY

WITH ITS LARGE BODY AND SIZABLE STRAINING ELEMENT, THE YS70 PROVIDES EXCELLENT OPEN AREA RATIOS THAT ARE TYPICALLY TWO-AND-A-HALF TIMES LARGER THAN THE CORRESPONDING PIPELINE.

♦ PRECISION MACHINED SEATS

PRECISION MACHINED SCREEN SEATS IN BOTH THE BODY AND CAP HELP TO ENSURE ACCURATE POSITIONING OF THE SCREEN DURING REASSEMBLY AFTER CLEANING. ALSO, THE MACHINED BODY SEATS ENABLE FINER FILTRATION BY PREVENTING DEBRIS BYPASS.

♦ REUSABLE RTJ GASKET

PRECISION MACHINED, RTJ GASKETS ARE PREFERRED FOR HIGH PRESSURE AND HIGH TEMPERATURE SERVICES BECAUSE THEY PROVIDE A TIGHT, EFFICIENT SEAL AND A LONG SERVICE LIFE.

♦ SELF-CLEANING CAPABILITY

WITH THE OPTIONAL SOCKET WELD BLOW-OFF CONNECTION, THIS UNIT CAN BE FITTED WITH A BLOW-DOWN VALVE WHICH FACILITATES CLEANING OF THE STRAINING ELEMENT. PLEASE CONTACT FACTORY FOR MORE INFORMATION.

♦ EPOXY PAINTED

CARBON UNITS ARE EPOXY PAINTED TO HELP RESIST RUST AND CORROSION. TITAN FCI ALSO OFFERS EPOXY COATING. PLEASE CONTACT FACTORY FOR MORE INFORMATION.

TECHNICAL

PRESSURE/TEMPERATURE RATING
CS - ASTM A216 GR. WCB - CLASS 2500

WOG (Non-shock): 6170 PSI @ 100 °F

PRESSURE/TEMPERATURE RATING
SS - ASTM A351 GR. CF8M - CLASS 2500

WOG (Non-shock): 6000 PSI @ 100 °F

- The above listed temperatures are theoretical and may vary during actual operating conditions.
- Carbon Steel not recommended for prolonged use above 800 °F.
- Stainless Steel not recommended for prolonged use above 1000 °F.

APPLICATIONS

CARBON STEEL PROPERTIES: CARBON STEEL PERFORMS EXCEPTIONALLY WELL IN HIGH TEMPERATURES, UP TO 800°F IN CONTINUOUS SERVICE. IT PROVIDES HIGH RESISTANCE TO SHOCK, VIBRATION, PIPING STRAINS, AND FIRE AND FREEZING HAZARDS. CARBON STEEL STRAINERS ARE OFTEN USED IN THE OIL AND PETROCHEMICAL INDUSTRIES.

STAINLESS STEEL PROPERTIES: STAINLESS STEEL IS COMMONLY SPECIFIED FOR HIGH TEMPERATURE SERVICE, UP TO 1000°F IN CONTINUOUS SERVICE. STAINLESS STEEL STRAINERS ARE COMMONLY FOUND IN THE CHEMICAL, FOOD, AND PHARMACEUTICAL INDUSTRIES.

The above data represents common market and service applications. No representation or guarantee, expressed or implied, is given due to the numerous variations of concentrations, temperatures and flow conditions that may occur during actual service.

TITAN FLOW CONTROL, INC.

YOUR PIPELINE TO THE FUTURE!

Tel: 910-735-0000 ♦ Fax: 910-738-3848 ♦ titan@titanfci.com ♦ www.titanfci.com
290 Corporate Drive ♦ PO Box 7408 ♦ Lumberton, NC 28358



TITAN FLOW CONTROL, Inc.

290 Corporate Drive
Lumberton, NC 28358
Tel: 910.735.0000

E-mail: titan@titanfci.com
Web: www.titanfci.com
Fax: 910.738.3848

WYE STRAINER

YS 70-CS - (Carbon Steel)
YS 70-SS - (Stainless Steel)

ANSI Class
2500

Flanged Ends • RTJ Raised Face • Carbon & Stainless Steel

BILL OF MATERIALS ⁽¹⁾

No.	PART	YS 70-CS ⁽³⁾	YS 70-SS
1	Body	Carbon Steel A216 Gr.WCB	Stainless Steel A351 Gr. CF8M
2	Cover	Carbon Steel A216 Gr.WCB	Stainless Steel A351 Gr. CF8M
3	Straining Element ⁽²⁾	Stainless Steel	Stainless Steel
4	Gasket ⁽²⁾	RTJ Gasket	RTJ Gasket
5	Studs	Alloy Steel	Alloy Steel
6	Nuts	Alloy Steel	Alloy Steel

1. Bill of Materials represents standard materials. Equivalent or better materials may be substituted at the manufacturer's discretion.
2. Denotes recommended spare parts.
3. Carbon Steel bodies are epoxy painted.

Additional Design & Technical Notes:

- Ring Type Joint, Raised Face Flanges are standard end connections for the YS 70. Contact factory for non-standard options.
- An optional socket weld blow-off is available. Please contact factory.
- NPT blow-offs are not recommended for ANSI Class 2500 strainers.
- Bodies are also available in high temperature steel A217 Gr. WC6 and WC9. Please contact factory for price and delivery.

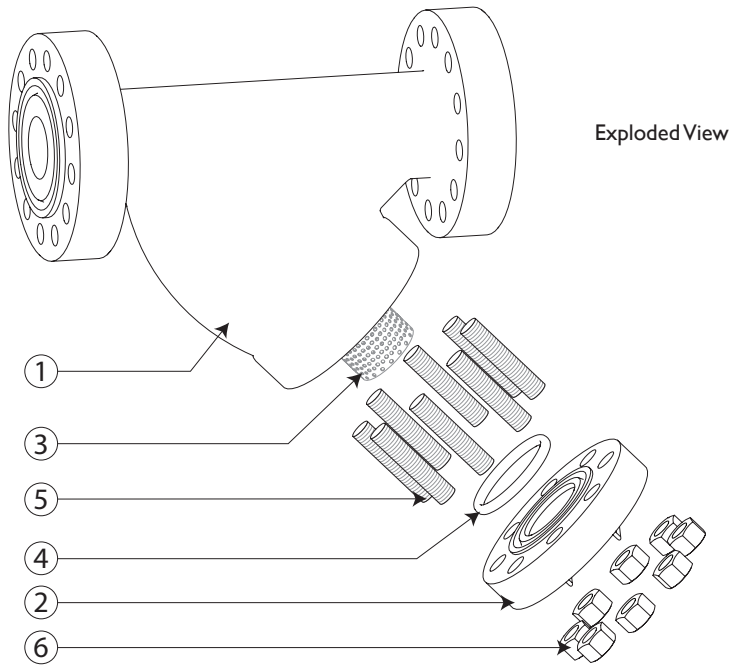

Illustrations are representative of sizes 2" through 8".
Please ask for certified drawings when required.

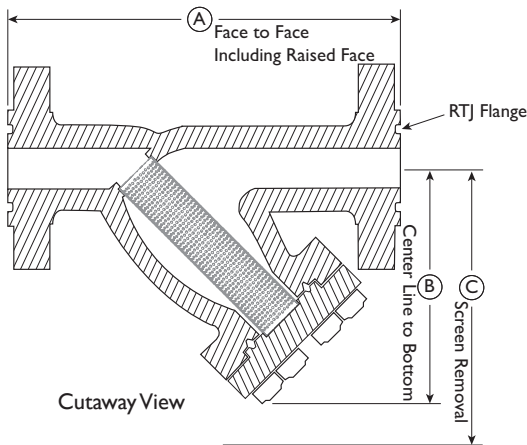

DIMENSIONS AND PERFORMANCE DATA ⁽¹⁾

SIZE	in	2	3	4	6	8
	mm	50	80	100	150	200
A DIMENSION FACE TO FACE ⁽²⁾	in	16.26	22.0	29.12	36.75	45.0
	mm	413	559	740	933	1143
B DIMENSION CENTER LINE TO BOTTOM	in	10.5	13.0	17.0	21.73	29.0
	mm	267	330	432	552	737
C DIMENSION SCREEN REMOVAL	in	14.0	20.0	25.0	31.0	50.0
	mm	356	508	635	787	1270
APPROXIMATE ASSEMBLED WEIGHT ⁽³⁾	lb	C/F	350	550	C/F	C/F
	kg	C/F	158.8	249	C/F	C/F
Flow Coefficient	C _v	42	100	160	375	600

1. Dimensions and weights are for reference only. When required, request certified drawings.
2. Face to face values have a tolerance of ±0.06 in (±2.0 mm) for sizes 10" and lower.
3. Contact factory for weight of the 2", 3", 6", and 8" YS 70 if required.

PRESSURE - TEMPERATURE RATING

Body Material	A216 Gr.WCB	A351 Gr. CF8M
WOG (Non-shock):	6170 PSI @ 100 °F	6000 PSI @ 100 °F

REFERENCED STANDARDS & CODES

CODE	DESCRIPTION
ASME/ANSI B 16.5	Pipe Flanges and Flanged Fittings
ASME/ANSI B 16.34	Flanged, Threaded, and Welding End

STANDARD SCREEN SELECTIONS

Size	Liquid	Open Area	Steam	Open Area
2" ~ 4"	1/16 (.0625)	41%	1/32 (.033)	28%
5" ~ 8"	1/8 (.125)	40%	3/64 (.045)	36%

PRESSURE - TEMPERATURE RATINGS

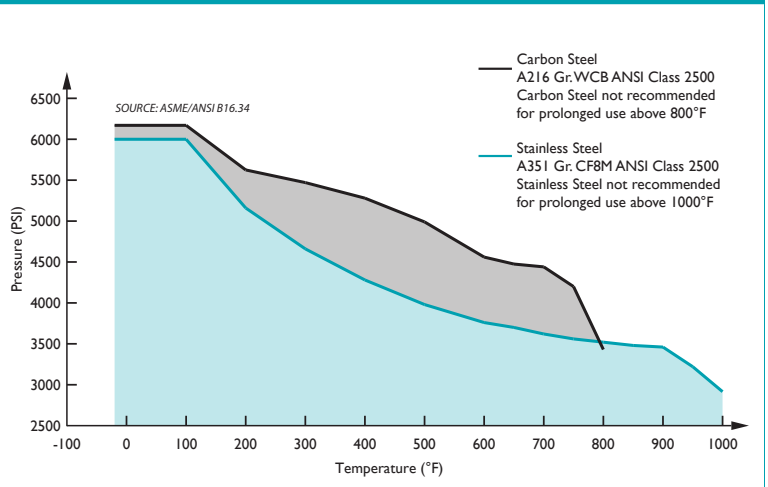

Titan FCI makes every effort to ensure the information presented on our literature accurately reflects exact product specifications. However, as product changes occur, there may be short-term differences between actual product specifications and the information contained within our literature. Titan FCI reserves the right to make design and specification changes to improve our products without prior notification. When required, request certified drawings.



TITAN FLOW CONTROL, INC.

"Y" (WYE) STRAINER ♦ BUTT WELD ENDS

ANSI CLASS 2500 ♦ CARBON AND STAINLESS STEEL

MODELS: YS 71-CS

(CARBON STEEL)

YS 71-SS

(STAINLESS STEEL)

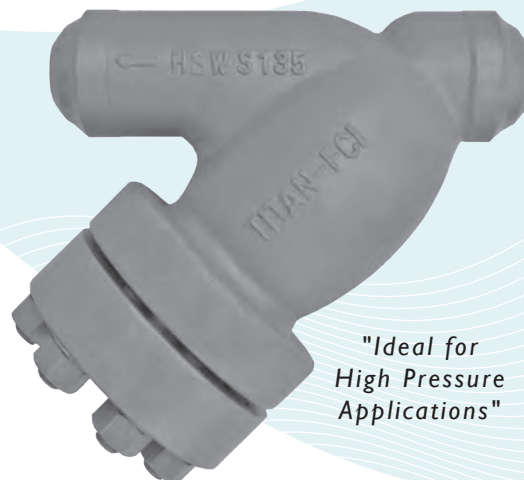

"Ideal for
High Pressure
Applications"

FEATURES

SIZES: 1" ~ 10"

♦ RUGGED - HIGH QUALITY DESIGN

TITAN'S YS71 IS IDEAL FOR POWER GENERATION AND OTHER DEMANDING INDUSTRIAL APPLICATIONS THAT HAVE HIGHER PRESSURE AND TEMPERATURE REQUIREMENTS. THIS UNIT EMPLOYES HEAVY GAUGE, REINFORCED SCREENS TO PREVENT DAMAGE TO THE STRAINING ELEMENT. BOLT HOLES ARE BACK OR SPOT FACED.

♦ LARGE STRAINING CAPACITY

WITH ITS LARGE BODY AND SIZABLE STRAINING ELEMENT, THE YS71 PROVIDES EXCELLENT OPEN AREA RATIOS THAT ARE TYPICALLY TWO-AND-A-HALF TIMES LARGER THAN THE CORRESPONDING PIPELINE.

♦ PRECISION MACHINED SEATS

PRECISION MACHINED SCREEN SEATS IN BOTH THE BODY AND CAP HELP TO ENSURE ACCURATE POSITIONING OF THE SCREEN DURING REASSEMBLY AFTER CLEANING. ALSO, THE MACHINED BODY SEATS ENABLE FINER FILTRATION BY PREVENTING DEBRIS BYPASS.

♦ REUSABLE RTJ GASKET

PRECISION MACHINED, RTJ GASKETS ARE PREFERRED FOR HIGH PRESSURE AND HIGH TEMPERATURE SERVICES BECAUSE THEY PROVIDE A TIGHT, EFFICIENT SEAL AND A LONG SERVICE LIFE.

♦ SELF-CLEANING CAPABILITY

WITH THE OPTIONAL SOCKET WELD BLOW-OFF CONNECTION, THIS UNIT CAN BE FITTED WITH A BLOW-DOWN VALVE WHICH FACILITATES CLEANING OF THE STRAINING ELEMENT. PLEASE CONTACT FACTORY FOR MORE INFORMATION.

♦ EPOXY PAINTED

CARBON UNITS ARE EPOXY PAINTED TO HELP RESIST RUST AND CORROSION. TITAN FCI ALSO OFFERS EPOXY COATING. PLEASE CONTACT FACTORY FOR MORE INFORMATION.

TECHNICAL

PRESSURE/ TEMPERATURE RATING
CS - ASTM A216 GR. WCB - CLASS 2500

WOG (Non-shock): 6170 PSI @ 100 °F

PRESSURE/ TEMPERATURE RATING
SS - ASTM A351 GR. CF8M - CLASS 2500

WOG (Non-shock): 6000 PSI @ 100 °F

- The above listed temperatures are theoretical and may vary during actual operating conditions.
- Carbon Steel not recommended for prolonged use above 800 °F.
- Stainless Steel not recommended for prolonged use above 1000 °F.

APPLICATIONS

CARBON STEEL PROPERTIES: CARBON STEEL PERFORMS EXCEPTIONALLY WELL IN HIGH TEMPERATURES, UP TO 800°F IN CONTINUOUS SERVICE. IT PROVIDES HIGH RESISTANCE TO SHOCK, VIBRATION, PIPING STRAINS, AND FIRE AND FREEZING HAZARDS. CARBON STEEL STRAINERS ARE OFTEN USED IN THE OIL AND PETROCHEMICAL INDUSTRIES.

STAINLESS STEEL PROPERTIES: STAINLESS STEEL IS COMMONLY SPECIFIED FOR HIGH TEMPERATURE SERVICE, UP TO 1000°F IN CONTINUOUS SERVICE. STAINLESS STEEL STRAINERS ARE COMMONLY FOUND IN THE CHEMICAL, FOOD, AND PHARMACEUTICAL INDUSTRIES.

The above data represents common market and service applications. No representation or guarantee, expressed or implied, is given due to the numerous variations of concentrations, temperatures and flow conditions that may occur during actual service.

TITAN FLOW CONTROL, INC.

YOUR PIPELINE TO THE FUTURE!

Tel: 910-735-0000 ♦ Fax: 910-738-3848 ♦ titan@titanfci.com ♦ www.titanfci.com
290 Corporate Drive ♦ PO Box 7408 ♦ Lumberton, NC 28358



TITAN FLOW CONTROL, Inc.

290 Corporate Drive
Lumberton, NC 28358
Tel: 910.735.0000

E-mail: titan@titanfci.com
Web: www.titanfci.com
Fax: 910.738.3848

WYE STRAINER

YS 71-CS - (Carbon Steel)
YS 71-SS - (Stainless Steel)

Butt Weld Ends • Carbon & Stainless Steel

ANSI Class
2500

BILL OF MATERIALS ⁽¹⁾

No.	PART	YS 71-CS ⁽³⁾	YS 71-SS
1	Body	Carbon Steel A216 Gr.WCB	Stainless Steel A351 Gr.CF8M
2	Cover	Carbon Steel A216 Gr.WCB	Stainless Steel A351 Gr.CF8M
3	Straining Element ⁽²⁾	Stainless Steel	Stainless Steel
4	Gasket ⁽²⁾	RTJ Gasket	RTJ Gasket
5	Studs	Alloy Steel	Alloy Steel
6	Nuts	Alloy Steel	Alloy Steel

1. Bill of Materials represents standard materials. Equivalent or better materials may be substituted at the manufacturer's discretion.
2. Denotes recommended spare parts.
3. Carbon Steel bodies are epoxy painted.

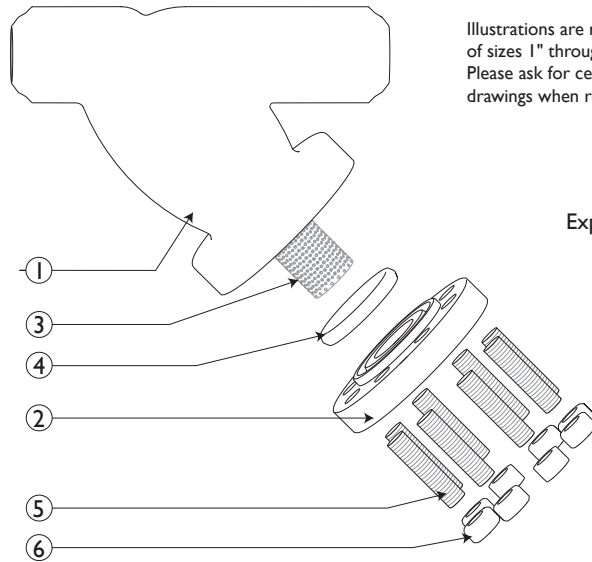

Illustrations are representative of sizes 1" through 10". Please ask for certified drawings when required.

Exploded View

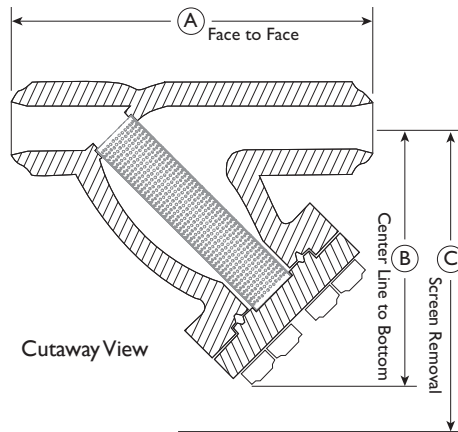

Cutaway View

ANSI Class 2500 Butt Welded ends have a schedule of XXS.

DIMENSIONS AND PERFORMANCE DATA ⁽¹⁾

SIZE	in	1	1 1/2	2	3	4	6	8	10 ⁽²⁾
	mm	25	40	50	80	100	150	200	250
A DIMENSION FACE TO FACE	in	9.26	12.0	12.0	18.0	24.0	27.0	33.0	40.0
	mm	235	305	305	457	610	686	838	1016
B DIMENSION CENTER LINE TO BOTTOM	in	8.55	11.0	11.0	15.0	17.0	21.73	29.0	31.86
	mm	218	279	279	381	432	552	737	809
C DIMENSION SCREEN REMOVAL	in	15.0	12.0	12.0	20.0	25.0	31.0	50.0	50.0
	mm	508	305	305	508	653	787	1270	1270
APPROXIMATE ASSEMBLED WEIGHT	lb	39	64	64	169	307	688	1465	C/F
	kg	17	29	29	77	139	312	665	C/F
Flow Coefficient	C _v	9	30	42	100	160	375	600	C/F

1. Dimensions, weights, and flow coefficients are for reference only. When required, request certified drawings.
2. Contact factory for weight of the 10" YS 71 if required.

REFERENCED STANDARDS & CODES

CODE	DESCRIPTION
ASME/ANSI B16.25	Butt Welding Ends
ASME/ANSI B16.34	Flanged, Threaded, and Welding End

STANDARD SCREEN SELECTIONS

Size	Liquid	Open Area	Steam	Open Area
1" ~ 4"	1/16 (.0625)	41%	1/32 (.033)	28%
5" ~ 8"	1/8 (.125)	40%	3/64 (.045)	36%

Additional Design & Technical Notes:

- An optional socket weld blow-off is available. Please contact factory.
- NPT blow-offs are not recommended for ANSI Class 2500 strainers.
- Bodies are also available in high temperature steel A217 Gr. WC6 and WC9. Please contact factory for price and delivery.
- Socket Weld End Connections are available for sizes 2" and under; ask about Titan's ANSI 2500 YS 86 y-strainers.

PRESSURE - TEMPERATURE RATINGS

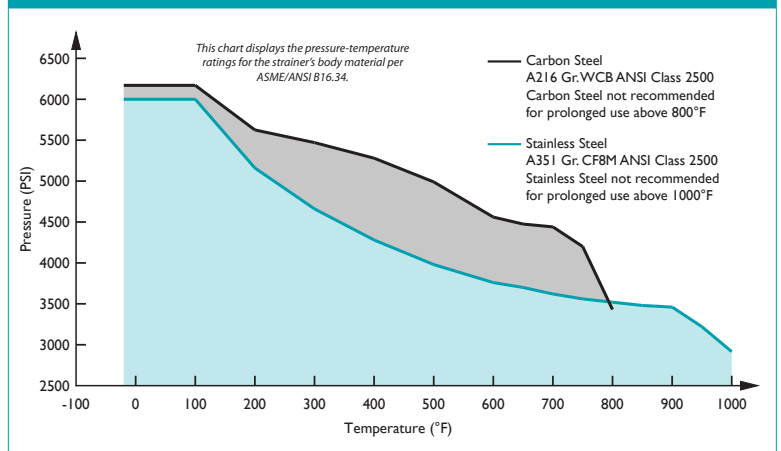

PRESSURE - TEMPERATURE RATING

Body Material	A216 Gr.WCB	A351 Gr. CF8M
WOG (Non-shock):	6170 PSI @ 100 °F	6000 PSI @ 100 °F

Titan FCI makes every effort to ensure the information presented on our literature accurately reflects exact product specifications. However, as product changes occur, there may be short-term differences between actual product specifications and the information contained within our literature. Titan FCI reserves the right to make design and specification changes to improve our products without prior notification. When required, request certified drawings.



TITAN FLOW CONTROL, INC.

SIMPLEX BASKET STRAINER ♦ THREADED & FLANGED END

ANSI CLASS 125 ♦ CAST IRON BODY ♦ QUICK-OPEN COVER

MODELS: BS 25-CI

(THREADED)

SIZES: 3/8" ~ 3"

BS 25F-CI

(FLANGED - FLAT FACED)

SIZES: 1" ~ 8"

FEATURES

◇ VERSATILE - HIGH QUALITY CONSTRUCTION

THIS BASKET STRAINER IS AVAILABLE WITH EITHER THREADED (BS 25-CI) OR FLAT-FACED FLANGED ENDS (BS 25F-CI). BOTH MODELS HAVE EPOXY-PAINTED CAST IRON BODIES, PLUGGED DRAIN CONNECTIONS, AND SAFETY VENTS IN. A QUICK OPEN COVER COMES STANDARD, BUT A FULL ANSI RATED BOLTED COVER IS ALSO AVAILABLE.

◇ MINIMAL PRESSURE LOSS

PRESSURE LOSS IS MINIMIZED BY PROVIDING AN OVER-THE-TOP FLOW PATH AND LARGE OPEN AREA RATIO. THE STRAINING CAPACITY IS A MINIMUM OF SIX TIMES THAT OF THE CONNECTING PIPE.

◇ LARGE STRAINING CAPACITY

WITH ITS LARGE BODY AND SIZEABLE STRAINING ELEMENT, THIS BASKET STRAINER HAS THE ABILITY TO STORE LARGE QUANTITIES OF DEBRIS - THUS MAXIMIZING TIME BETWEEN SERVICING. IT ALSO FEATURES A MACHINED SEAT WITH O-RING THAT ENABLES FINE FILTRATIONS DOWN TO 40 MICRONS.

◇ NUMEROUS STRAINING ELEMENT OPTIONS

STRAINING ELEMENTS ARE AVAILABLE IN A VARIETY OF PERFORATIONS, MESHES, AND MATERIALS. SPECIAL DESIGNS ARE ALSO AVAILABLE INCLUDING MAGNETIC, WEDGE WIRE, DRILLED PERFORATIONS, AND PLEATED STRAINING ELEMENTS. THE STANDARD MATERIAL FOR STRAINING ELEMENTS IS TYPE 304 STAINLESS STEEL.

◇ SELF-CLEANING OPTION

UTILIZING A MODIFIED STRAINING ELEMENT, DRAINS CAN BE FITTED WITH A TITAN FCI BALL VALVE TO ALLOW FOR THE AUTOMATIC CLEANING OR FLUSHING OF THE STRAINING ELEMENT WHILE KEEPING THE PIPELINE IN SERVICE.

◇ POTABLE WATER/FDA APPROVED COATINGS AVAILABLE



IN ADDITION TO ITS LEAD FREE, CAST IRON BODY, TITAN CAN PROVIDE NSF/ANSI AND FDA APPROVED EPOXY COATINGS WHICH MAKE THIS PRODUCT SUITABLE FOR POTABLE WATER AND FOOD CONTACT APPLICATIONS. NUMEROUS OPTIONS ARE AVAILABLE. PLEASE CONTACT US FOR MORE DETAILS.

3/8" - 3" Standard Quick-Open Cover is Knob Style.

4" - 8" Standard Quick-Open Cover is Clamp Style.

Designed for easy maintenance and large straining capacities!

4" BS 25F-CI is shown with standard Quick-Open Cover & removable leg brackets.

Side Drain is standard on sizes 4" and up.



TECHNICAL

PRESSURE/TEMPERATURE RATING ⁽¹⁾ CAST IRON ASTM A126 GR. B - CLASS 125

BS 25-CI (Threaded) ⁽²⁾
WOG: 200 PSI @ 100 °F

BS 25F-CI (Flanged) ⁽²⁾
WOG: 200 PSI @ 100 °F

- The above listed temperatures are theoretical and may vary during actual operating conditions.
- Quick-Open (knob-type) cover is not recommended for steam or high temperature. Full ANSI rated bolted cover is also available.

APPLICATIONS

MARKETS: WATER & WASTEWATER, PULP & PAPER, CHEMICAL & PETROCHEMICAL, PETROLEUM, OIL & GAS, TRANSPORTATION, MARINE INDUSTRY, AND FOOD INDUSTRY

GENERAL APPLICATION: SIMPLEX BASKET STRAINERS ARE INSTALLED INTO A PIPELINE SYSTEM TO REMOVE UNWANTED DEBRIS FROM THE PIPELINE FLOW. BASKET STRAINERS ARE COMMONLY USED IN HORIZONTAL PIPELINES WHERE DEBRIS LOADING IS HIGH AND THE COLLECTION OF SOLIDS IS REQUIRED. STRAINING IS ACCOMPLISHED VIA A PERFORATED OR MESH LINED STRAINING ELEMENT, INTERNAL TO THE BASKET STRAINER. IN GENERAL, THE SIZE OF THE PERFORATION OR MESH SHOULD BE SLIGHTLY SMALLER THAN THE SMALLEST DEBRIS PARTICLE TO BE REMOVED. IT IS IMPORTANT TO NOTE THAT THE CORRECT SIZE OF A BASKET STRAINER IS DETERMINED BY ITS JOB FUNCTION, NOT BY THE SIZE OF THE PIPELINE.

The above data represents common market and service applications. No representation or guarantee, expressed or implied, is given due to the numerous variations of concentrations, temperatures and flow conditions that may occur during actual service.

TITAN FLOW CONTROL, INC.

YOUR PIPELINE TO THE FUTURE!

Tel: 910-735-0000 ♦ Fax: 910-738-3848 ♦ titan@titanfci.com ♦ www.titanfci.com
290 Corporate Drive ♦ PO Box 7408 ♦ Lumberton, NC 28358



TITAN FLOW CONTROL, Inc.

290 Corporate Drive
Lumberton, NC 28358
Tel: 910.735.0000

E-mail: titan@titanfci.com
Web: www.titanfci.com
Fax: 910.738.3848

SIMPLEX BASKET STRAINER

BS 25-CI - (Threaded)

BS 25F-CI - (Flanged - Flat Faced)

Flanged & Threaded Ends • Quick-Open Cover • Cast Iron

ANSI
Class 125

BILL OF MATERIALS (1)

No.	PART	BS 25-CI and BS 25F-CI
1	Body (2)	Cast Iron ASTM A126 Gr. B
2	Cover	Knob Cover: Cast Iron ASTM A126 Gr. B Clamp Cover: Carbon Steel A516-70
3	O-Ring / Gasket (3)	Buna-N
4	Straining Element (3)	Type 304 Stainless Steel
5	Studs	Zinc Plated Alloy Steel
6	Knobs	Zinc Plated Ductile Iron
7	Drain Plugs	Carbon Steel
8	Clamp	Zinc Plated Ductile Iron
9	Bolts	Zinc Plated Alloy Steel A 193-B7
10	Tee Handle	Zinc Plated Carbon Steel

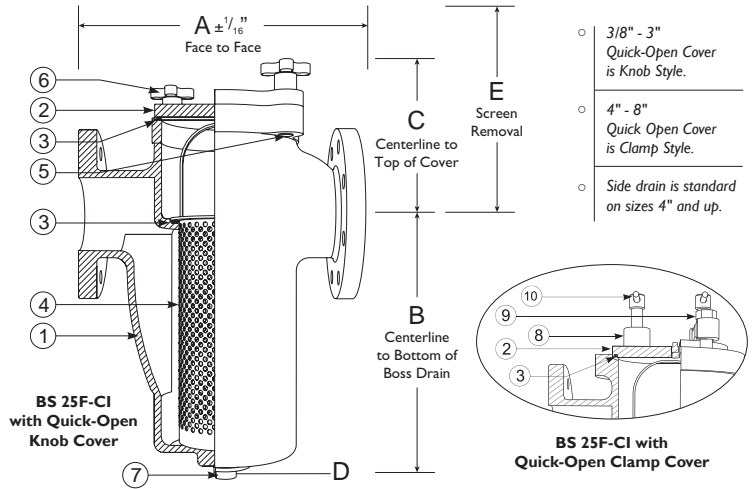

- 3/8" - 3" Quick-Open Cover is Knob Style.
- 4" - 8" Quick Open Cover is Clamp Style.
- Side drain is standard on sizes 4" and up.

1. Equivalent or better materials may be substituted at the manufacturer's discretion.
2. Cast Iron bodies are epoxy painted.
3. Denotes recommended spare parts.

Illustration displays flanged end connections only (BS 25F). Tables to the left and below contain dimensions and material information for both threaded and flanged types. Contact factory for more information on the optional bolted cover. When required, always request certified drawings.

DIMENSIONS AND PERFORMANCE DATA (1)

Size	in	3/8	1/2	3/4	1	1 1/4	1 1/2	2	2 1/2	3	4	6	8
	mm	10	15	20	25	32	40	50	65	80	100	150	200
A_T DIMENSION FACE TO FACE (THREADED)	in	4.562	4.562	4.562	5.312	6.312	6.312	8.25	9.625	11.25	n/a	n/a	n/a
	mm	116	116	116	135	161	161	210	245	286	n/a	n/a	n/a
A_F DIMENSION FACE TO FACE (FLANGED)	in	n/a	n/a	n/a	5.687	n/a	7.00	9.00	10.44	11.75	15.00	20.25	27.38
	mm	n/a	n/a	n/a	145	n/a	178	229	267	299	381	515	696
B_T DIMENSION CTR. TO BOSS BOTTOM (THREADED)	in	4.00	4.00	4.00	4.687	6.50	6.50	7.875	8.75	11.375	n/a	n/a	n/a
	mm	102	102	102	120	166	166	201	223	289	n/a	n/a	n/a
B_F DIMENSION CTR. TO BOSS BOTTOM (FLANGED)	in	n/a	n/a	n/a	4.687	n/a	6.50	8.00	8.75	11.50	13.75	20.00	24.24
	mm	n/a	n/a	n/a	120	n/a	166	204	223	293	350	508	616
C_T DIMENSION CTR. LINE TO TOP (THREADED)	in	2.50	2.50	2.50	2.75	3.00	3.00	3.625	4.00	4.50	n/a	n/a	n/a
	mm	64	64	64	70	77	77	93	102	115	n/a	n/a	n/a
C_F DIMENSION CTR. LINE TO TOP (FLANGED)	in	n/a	n/a	n/a	3.00	n/a	3.00	3.75	4.00	4.75	7.00	8.45	12.00
	mm	n/a	n/a	n/a	77	n/a	77	96	102	121	178	215	305
D DIMENSION NPT BLOW-OFF (BOTH)	in	3/8	3/8	3/8	3/8	1/2	1/2	3/4	1	1	2	2	2
	mm	10	10	10	10	15	15	20	25	25	50	50	50
E DIMENSION SCREEN REMOVAL (BOTH)	in	4.812	4.812	4.812	5.875	8.125	8.125	10.125	11.875	14.812	19.875	29.125	29.125
	mm	123	123	123	150	207	207	258	302	377	505	740	943
ASSEMBLED WEIGHT THREADED (APPROXIMATE)	lb	5.5	5.5	5.0	8.0	15.0	14.0	27.0	36.0	55.5	n/a	n/a	n/a
	kg	2.5	2.5	2.3	3.6	6.8	6.4	12.2	16.3	25.2	n/a	n/a	n/a
ASSEMBLED WEIGHT FLANGED (APPROXIMATE)	lb	n/a	n/a	n/a	11.5	n/a	21.0	34.0	48.5	64.0	118.0	266.0	518.0
	kg	n/a	n/a	n/a	5.2	n/a	9.5	15.4	22.0	29.0	53.5	120.7	235.0
Flow Coefficient	C _v	14	14	14	23	42	42	70	90	140	290	780	1600

1. Dimensions, weights, and flow coefficients are provided for reference only. When required, always request certified drawings.

PRESSURE - TEMPERATURE RATINGS (1)

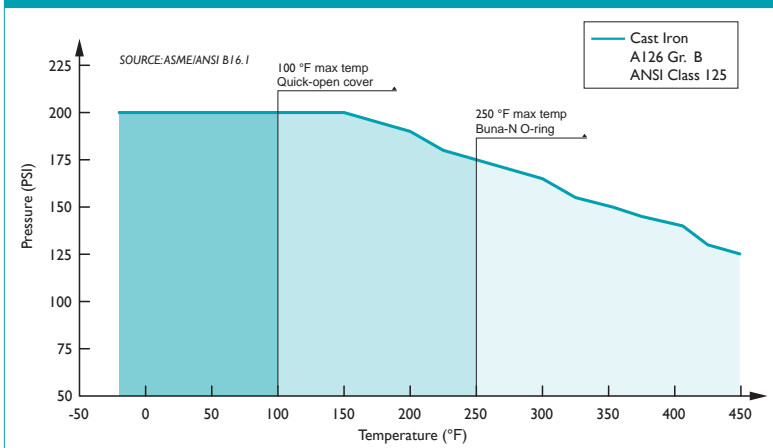

1. This chart displays the pressure-temperature ratings for the strainer's body material per ANSI B16.1. Max temperature limits have been added for Quick-Open cover and Buna-N O-ring.

Titan FCI makes every effort to ensure the information presented on our literature accurately reflects exact product specifications. However, as product changes occur, there may be short-term differences between actual product specifications and the information contained within our literature. Titan FCI reserves the right to make design and specification changes to improve our products without prior notification. When required, request certified drawings.

REFERENCED STANDARDS & CODES

CODE	DESCRIPTION
ASME/ANSI B16.1	Cast Iron Pipe Flanges and Flanged Fittings
ASME/ANSI B16.4	Cast Iron Threaded Fittings

PRESSURE - TEMPERATURE RATING

ANSI CLASS 125	BS 25-CI	BS 25F-CI
WOG (water, oil, gas)	200 PSI @ 100 °F	200 PSI @ 100 °F

1. Quick-Open cover is not recommended for steam or high temperatures. Full ANSI rated bolted cover is also available.

STANDARD SCREEN SELECTIONS

Size	Liquid	Open Area	Steam	Open Area
3/8" ~ 2"	1/16 (.0625)	41%	1/32 (.033)	28%
2 1/2" ~ 4"	1/16 (.0625)	41%	3/64 (.045)	36%
5" ~ 8"	1/8 (.125)	40%	3/64 (.045)	36%



TITAN FLOW CONTROL, INC.

SIMPLEX BASKET STRAINER ♦ RF FLANGED & THREADED ANSI CLASS 150/300 ♦ CARBON AND STAINLESS STEEL

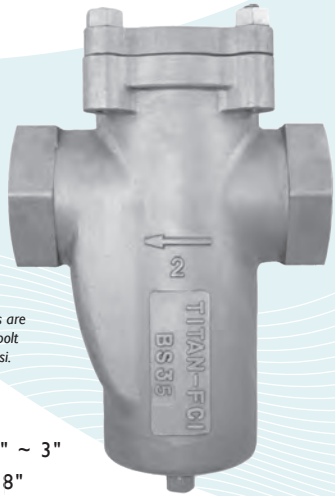

• Quick-opening cover designs are available. Quick-opening, two bolt cover option is rated at 150 psi.

SIZE RANGE:
THREADED: 3/8" ~ 3"
FLANGED: 1" ~ 8"

MODELS: **BS 35-CS**
(CARBON STEEL - THREADED - 150/300)

BS 35F-CS
(CARBON STEEL - RF FLANGED - 150)

BS 35-SS
(STAINLESS STEEL - THREADED - 150/300)

BS 35F-SS
(STAINLESS STEEL - RF FLANGED - 150)

FEATURES

- ♦ **HIGH QUALITY CONSTRUCTION**
THE SERIES BS35 BASKET STRAINER IS AVAILABLE IN CARBON OR STAINLESS STEEL WITH EITHER THREADED OR FLANGED (RF) END CONNECTIONS. IT FEATURES A MACHINED GROOVE THAT ENCAPSULATES THE COVER GASKET AND AIDS IN PREVENTING GASKET BLOW-OUTS.
- ♦ **MINIMAL PRESSURE LOSS**
PRESSURE LOSS IS MINIMIZED BY PROVIDING AN OVER-THE-TOP FLOW PATH AND LARGE STRAINING AREA. THE STRAINING CAPACITY IS A MINIMUM OF SIX TIMES THAT OF THE CROSS SECTIONAL AREA OF THE CONNECTING PIPE.
- ♦ **LARGE STRAINING CAPACITY**
WITH ITS LARGE BODY AND SIZEABLE STRAINING ELEMENT, THE SERIES BS35 BASKET STRAINER CAN STORE LARGE AMOUNTS OF DEBRIS - THUS MAXIMIZING TIME BETWEEN SERVICING. IT ALSO FEATURES A MACHINED SEAT WITH O-RING THAT ENABLES FINE FILTRATIONS - DOWN TO 40 MICRONS.
- ♦ **NUMEROUS STRAINING ELEMENT OPTIONS**
STRAINING ELEMENTS ARE AVAILABLE IN A VARIETY OF PERFORATIONS, MESHES, AND MATERIALS. SPECIAL DESIGNS ARE ALSO AVAILABLE INCLUDING MAGNETIC, WEDGE WIRE, DRILLED PERFORATIONS, AND PLEATED STRAINING ELEMENTS. THE STANDARD MATERIAL FOR STRAINING ELEMENTS IS TYPE 304 STAINLESS STEEL.
- ♦ **SELF-CLEANING OPTION**
UTILIZING A MODIFIED STRAINING ELEMENT, THE BOTTOM DRAIN CAN BE FITTED WITH A TITAN FCI BALL VALVE TO ALLOW FOR THE AUTOMATIC CLEANING OR FLUSHING OF THE STRAINING ELEMENT WHILE KEEPING THE PIPELINE IN SERVICE.

TECHNICAL

PRESSURE/ TEMPERATURE RATING CS - ASTM A216 GR. WCB - CLASS 150
WOG (Non-shock): 285 PSI @ 100 °F
PRESSURE/ TEMPERATURE RATING SS - ASTM A351 GR. CF8M - CLASS 150
WOG (Non-shock): 275 PSI @ 100 °F
PRESSURE/ TEMPERATURE RATING CS - ASTM A216 GR. WCB - CLASS 300
WOG (Non-shock): 740 PSI @ 100 °F
PRESSURE/ TEMPERATURE RATING SS - ASTM A351 GR. CF8M - CLASS 300
WOG (Non-shock): 720 PSI @ 100 °F

APPLICATIONS

MARKETS: WATER & WASTEWATER, PULP & PAPER, CHEMICAL & PETROCHEMICAL, PETROLEUM, OIL & GAS, TRANSPORTATION, MARINE INDUSTRY, AND FOOD INDUSTRY

GENERAL APPLICATION: SIMPLEX BASKET STRAINERS ARE INSTALLED INTO A PIPELINE SYSTEM TO REMOVE UNWANTED DEBRIS FROM THE PIPELINE FLOW. BASKET STRAINERS ARE COMMONLY USED IN HORIZONTAL PIPELINES WHERE DEBRIS LOADING IS HIGH AND THE COLLECTION OF SOLIDS IS REQUIRED. STRAINING IS ACCOMPLISHED VIA A PERFORATED OR MESH LINED STRAINING ELEMENT, INTERNAL TO THE BASKET STRAINER. IN GENERAL, THE SIZE OF THE PERFORATION OR MESH SHOULD BE SLIGHTLY SMALLER THAN THE SMALLEST DEBRIS PARTICLE TO BE REMOVED. IT IS IMPORTANT TO NOTE THAT THE CORRECT SIZE OF A BASKET STRAINER IS DETERMINED BY ITS JOB FUNCTION, NOT BY THE SIZE OF THE PIPELINE.

The above data represents common market and service applications. No representation or guarantee, expressed or implied, is given due to the numerous variations of concentrations, temperatures and flow conditions that may occur during actual service.

TITAN FLOW CONTROL, INC.

YOUR PIPELINE TO THE FUTURE!

Tel: 910-735-0000 ♦ Fax: 910-738-3848 ♦ titan@titanfci.com ♦ www.titanfci.com
290 Corporate Drive ♦ PO Box 7408 ♦ Lumberton, NC 28358



TITAN FLOW CONTROL, Inc.
 290 Corporate Drive
 Lumberton, NC 28358
 Tel: 910.735.0000
 E-mail: titan@titanfci.com
 Web: www.titanfci.com
 Fax: 910.738.3848

SIMPLEX BASKET STRAINER

Threaded Ends (150/300 lb) Raised Face Flanged Ends (150 lb)
BS 35-CS (Carbon Steel) **BS 35F-CS** (Carbon Steel)
BS 35-SS (Stainless Steel) **BS 35F-SS** (Stainless Steel)

ANSI
 Class
 150/300 lb

BILL OF MATERIALS (1)

No.	PART	BS 35-CS & BS 35F-CS (2)	BS 35-SS & BS 35F-SS
1	Body	Carbon Steel A216 Gr. WCB	Stainless Steel A351 Gr. CF8M Type 316
2	Cover	Carbon Steel A216 Gr. WCB	Stainless Steel A351 Gr. CF8M Type 316
3	O-Ring (Basket) (3)	Buna-N	Viton
4	Gasket (Cover) (3)(4)(6)	Spiral Wound Stainless Steel Non-Asbestos	
5	Straining Element (3)	Type 304 Stainless Steel (Other materials are available)	
6	Studs	Alloy Steel A193-B7	Stainless Steel 18-8 Series 300
7	Nuts	Carbon Steel A194-2H	Stainless Steel 18-8 Series 300
8	Bottom Drain Plug	Carbon Steel	Stainless Steel

- Equivalent or better materials may be substituted at the manufacturer's discretion.
- Carbon Steel bodies are epoxy painted.
- Denotes recommended spare parts.
- Gasket is for the 4 bolt cover option, which is standard. If quick open cover is specified, the O-ring material for the cover is Buna-N on BS35-CS & BS35F-CS or Viton on BS35-SS & BS35F-SS.
- Bolted cover is standard (3/8" - 8"). Quick-open cover 3/8" - 3" is 2 bolt style. Quick-open cover 4" - 8" is clamp style.
- Carbon Fiber Compressed gasket may be substituted at the manufacturer's discretion.

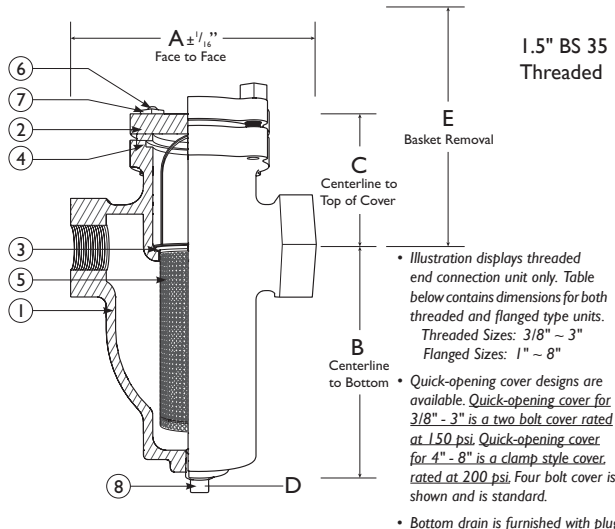

DIMENSIONS AND PERFORMANCE DATA (1)

Size	in	3/8	1/2	3/4	1	1 1/4	1 1/2	2	2 1/2	3	4	6	8
A₁ DIMENSION FACE TO FACE (THREADED)	in	4.562	4.562	4.562	5.312	6.312	6.312	8.25	11.25	11.25	n/a	n/a	n/a
	mm	116	116	116	135	161	161	210	286	286	n/a	n/a	n/a
A₂ DIMENSION FACE TO FACE (FLANGED)	in	n/a	n/a	n/a	5.687	n/a	7.00	9.00	10.375	11.75	15.00	20.25	27.375
	mm	n/a	n/a	n/a	145	n/a	178	229	264	299	381	515	696
B₁ DIMENSION CTR. LINE TO BOTTOM (THREADED)	in	4.00	4.00	4.00	4.687	6.50	6.50	7.875	8.75	11.375	n/a	n/a	n/a
	mm	102	102	102	120	166	166	201	223	289	n/a	n/a	n/a
B₂ DIMENSION CTR. LINE TO BOTTOM (FLANGED)	in	n/a	n/a	n/a	4.687	n/a	6.50	8.00	8.75	11.50	13.75	20.00	24.24
	mm	n/a	n/a	n/a	120	n/a	166	204	223	293	350	508	616
C₁ DIMENSION CTR. LINE TO TOP (THREADED)	in	2.50	2.50	2.50	2.75	3.00	3.00	3.625	4.00	4.50	n/a	n/a	n/a
	mm	64	64	64	70	77	77	93	102	115	n/a	n/a	n/a
C₂ DIMENSION CTR. LINE TO TOP (FLANGED)	in	n/a	n/a	n/a	3.00	n/a	3.00	3.75	4.00	4.75	6.18	7.88	10.55
	mm	n/a	n/a	n/a	77	n/a	77	96	102	121	157	201	268
D DIMENSION NPT BLOW-OFF (BOTH)	in	3/8	3/8	3/8	3/8	1/2	1/2	3/4	1	1	2	2	2
	mm	10	10	10	10	15	15	20	25	25	50	50	50
E DIMENSION SCREEN REMOVAL (BOTH)	in	4.812	4.812	4.812	5.875	8.125	8.125	10.125	11.875	14.812	19.875	29.125	37.125
	mm	123	123	123	150	207	207	258	302	377	505	740	943
ASSEMBLED WEIGHT THREADED (APPROXIMATE)	lb	6.0	6.0	5.5	8.0	16.0	16.0	25.5	49.0	51.0	n/a	n/a	n/a
	kg	2.7	2.7	2.5	3.6	7.3	7.3	11.6	22.2	23.1	n/a	n/a	n/a
ASSEMBLED WEIGHT FLANGED (APPROXIMATE)	lb	n/a	n/a	n/a	11.0	n/a	19.5	31.5	44.5	65.5	142.0	266.0	518.0
	kg	n/a	n/a	n/a	5.0	n/a	8.8	14.3	20.2	29.7	64.4	120.5	234.7
Flow Coefficient	C _v	14	14	14	23	42	42	70	90	140	290	780	1600

1. Dimensions, weights, and flow coefficients are provided for reference only. When required, always request certified drawings. • Threaded Sizes: 3/8" - 3" • Flanged Sizes: 1" - 8"

PRESSURE - TEMPERATURE RATINGS

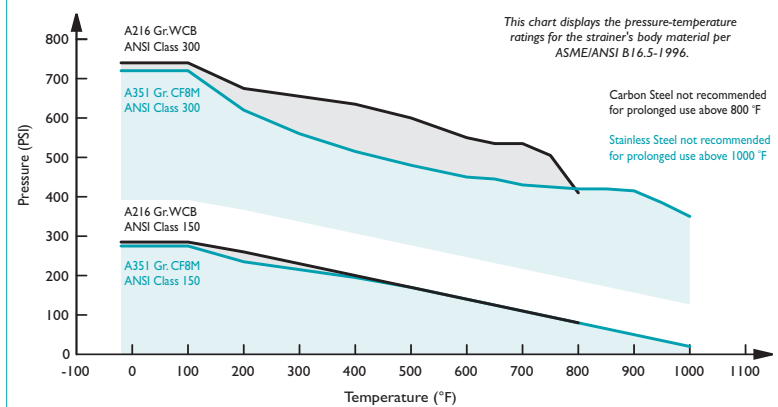

PRESSURE - TEMPERATURE RATING (1)

ANSI CLASS 150	A216 Gr. WCB (2)	A351 Gr. CF8M (2)
WOG (Non-shock)	285 PSI @ 100 °F	275 PSI @ 100 °F
ANSI CLASS 300	A216 Gr. WCB (2)	A351 Gr. CF8M (2)
WOG (Non-shock)	740 PSI @ 100 °F	720 PSI @ 100 °F

- Threaded units are dual rated ANSI Class 150/300. Flanged units are rated at ANSI Class 150.
- Pressure and Temperature ratings are considerably lower for units installed with the optional quick-opening covers. Please consult factory for further information.

STANDARD STRAINING ELEMENTS

Size	Liquid	Open Area	Steam	Open Area
3/8" - 2"	1/16 (.0625)	41%	1/32 (.033)	28%
2 1/2" - 4"	1/16 (.0625)	41%	3/64 (.045)	36%
5" - 8"	1/8 (.125)	40%	3/64 (.045)	36%

REFERENCED STANDARDS & CODES

Code	Description	Code	Description
ASME/ANSI B16.5	Pipe Flanges and Flanged Fittings	ASME/ANSI B16.11	Forged Steel Fittings, Socket-Welding and Threaded

Titan FCI makes every effort to ensure the information presented on our literature accurately reflects exact product specifications. However, as product changes occur, there may be short-term differences between actual product specifications and the information contained within our literature. Titan FCI reserves the right to make design and specification changes to improve our products without prior notification. When required, request certified drawings.



TITAN FLOW CONTROL, INC.

SIMPLEX BASKET STRAINER ♦ FLANGED ENDS - FLAT FACE

ANSI CLASS 125 ♦ CAST IRON ♦ CLAMPED & BOLTED COVER

MODELS: **BS 55-CI**
(CLAMPED COVER)

BS 65-CI
(BOLTED COVER)

SIZES: 2" ~ 20"

BS 55-CI is shown with clamp cover
and removable leg brackets

Side drain is standard, an optional
bottom drain is available



FEATURES

♦ VERSATILE - HIGH QUALITY DESIGN

THIS BASKET STRAINER IS AVAILABLE WITH EITHER A FULL RATED BOLTED COVER (BS65) OR CLAMPED COVER (BS55). BOTH MODELS ARE EPOXY PAINTED AND COME STANDARD WITH A PLUGGED SIDE DRAIN CONNECTION. LARGER SIZES (8" ~ 20") ALSO FEATURE REMOVABLE/ADJUSTABLE LEG BRACKETS.

♦ MINIMAL PRESSURE LOSS

PRESSURE LOSS IS MINIMIZED BY PROVIDING A SLANTED STRAINING ELEMENT DESIGN, A STRAIGHT-THROUGH FLOW PATH, AND A LARGE OPEN AREA RATIO. INLET AND OUTLET BOSSES ARE PROVIDED TO FACILITATE THE MOUNTING OF PRESSURE GAUGES TO MONITOR PRESSURE LOSS.

♦ LARGE STRAINING CAPACITY

WITH ITS LARGE BODY AND SIZEABLE STRAINING ELEMENT, THIS BASKET STRAINER HAS THE ABILITY TO STORE LARGE QUANTITIES OF DEBRIS WITHOUT AFFECTING PRESSURE LOSS - THUS MAXIMIZING TIME BETWEEN SERVICING.

♦ NUMEROUS STRAINING ELEMENT OPTIONS

STRAINING ELEMENTS ARE AVAILABLE IN A VARIETY OF PERFORATIONS, MESHES, AND MATERIALS. SPECIAL DESIGNS ARE ALSO AVAILABLE INCLUDING MAGNETIC, WEDGE WIRE, DRILLED PERFORATIONS, AND PLEATED STRAINING ELEMENTS. THE STANDARD MATERIAL FOR STRAINING ELEMENTS IS TYPE 304 STAINLESS STEEL.

♦ SELF-CLEANING OPTION

UTILIZING A MODIFIED STRAINING ELEMENT, THE BOTTOM DRAIN CAN BE FITTED WITH A TITAN FCI BALL VALVE TO ALLOW FOR THE AUTOMATIC CLEANING OR FLUSHING OF THE STRAINING ELEMENT WHILE KEEPING THE PIPELINE IN SERVICE.

♦ POTABLE WATER/FDA APPROVED COATINGS AVAILABLE



IN ADDITION TO ITS LEAD FREE, CAST IRON BODY, TITAN CAN PROVIDE NSF/ANSI AND FDA APPROVED EPOXY COATINGS WHICH MAKE THIS PRODUCT SUITABLE FOR POTABLE WATER AND FOOD CONTACT APPLICATIONS. NUMEROUS OPTIONS ARE AVAILABLE. PLEASE CONTACT US FOR MORE DETAILS.

TECHNICAL

PRESSURE/TEMPERATURE RATING CAST IRON ASTM A126 GR. B - CLASS 125

BS 55-CI (Clamped Cover) (2" ~ 12")
WOG (Non-shock): 200 PSI @ 100 °F

BS 65-CI (Bolted Cover) (2" ~ 12")
WOG (Non-shock): 200 PSI @ 150 °F

BS 55-CI (Clamped Cover) (14" ~ 20")
WOG (Non-shock): 100 PSI @ 100 °F

BS 65-CI (Bolted Cover) (14" ~ 20")
WOG (Non-shock): 150 PSI @ 150 °F

APPLICATIONS

MARKETS: WATER & WASTEWATER, PULP & PAPER, CHEMICAL & PETROCHEMICAL, PETROLEUM, OIL & GAS, TRANSPORTATION, MARINE INDUSTRY, AND FOOD INDUSTRY

GENERAL APPLICATION: SIMPLEX BASKET STRAINERS ARE INSTALLED INTO A PIPELINE SYSTEM TO REMOVE UNWANTED DEBRIS FROM THE PIPELINE FLOW. BASKET STRAINERS ARE COMMONLY USED IN HORIZONTAL PIPELINES WHERE DEBRIS LOADING IS HIGH AND THE COLLECTION OF SOLIDS IS REQUIRED. STRAINING IS ACCOMPLISHED VIA A PERFORATED OR MESH LINED STRAINING ELEMENT, INTERNAL TO THE BASKET STRAINER. IN GENERAL, THE SIZE OF THE PERFORATION OR MESH SHOULD BE SLIGHTLY SMALLER THAN THE SMALLEST DEBRIS PARTICLE TO BE REMOVED. IT IS IMPORTANT TO NOTE THAT THE CORRECT SIZE OF A BASKET STRAINER IS DETERMINED BY ITS JOB FUNCTION, NOT BY THE SIZE OF THE PIPELINE.

The above data represents common market and service applications. No representation or guarantee, expressed or implied, is given due to the numerous variations of concentrations, temperatures and flow conditions that may occur during actual service.

TITAN FLOW CONTROL, INC.

YOUR PIPELINE TO THE FUTURE!

Tel: 910-735-0000 ♦ Fax: 910-738-3848 ♦ titan@titanfci.com ♦ www.titanfci.com
290 Corporate Drive ♦ PO Box 7408 ♦ Lumberton, NC 28358



TITAN FLOW CONTROL, Inc.
 290 Corporate Drive
 Lumberton, NC 28358
 Tel: 910.735.0000
 E-mail: titan@titanfci.com
 Web: www.titanfci.com
 Fax: 910.738.3848

SIMPLEX BASKET STRAINER

BS 55-CI - (Clamped Cover)
BS 65-CI - (Bolted Cover)

Flanged Ends • Flat Face • Cast Iron Body

**ANSI
 Class 125**

BILL OF MATERIALS (1)

No.	PART	BS 65-CI	BS 55-CI
1	Body (2)	Cast Iron ASTM A126 Gr. B	
2	Cover	Cast Iron ASTM A126 Gr. B	
3	Cover Gasket (3)	Non-Asbestos - BS65(4)	Buna-N O-Ring - BS55
4	Straining Element (3)	Type 304 Stainless Steel	
5	Cap Screws	Zinc Plated Carbon Steel	
6	Plugs (Boss/Drain)	Cast Iron	

- Equivalent or better materials may be substituted at the manufacturer's discretion.
- Cast Iron bodies are epoxy painted.
- Denotes recommended spare parts.
- Carbon Fiber Compressed gasket may be substituted at the manufacturer's discretion.

STANDARD SCREEN SELECTIONS

Size	Liquid	Open Area	Steam	Open Area
2" ~ 4"	1/16 (.0625)	41%	3/64 (.045)	36%
5" ~ 12"	1/8 (.125)	40%	3/64 (.045) (1)	36%

1. For 10" and above, consult factory on screen selections for steam.

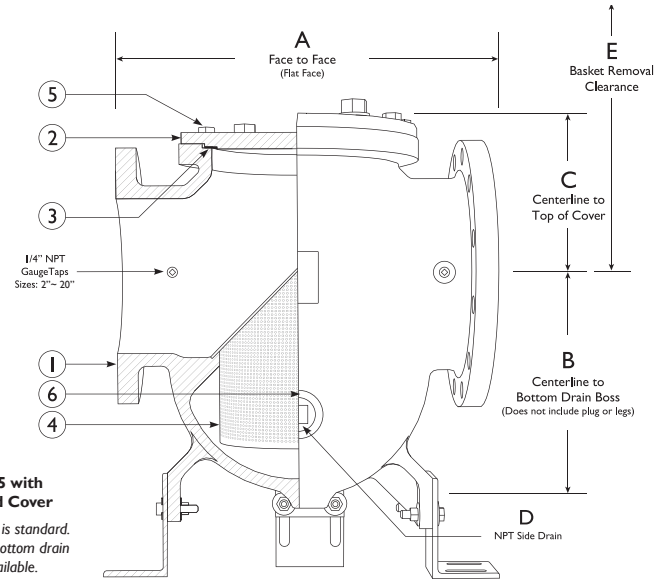

DIMENSIONS AND PERFORMANCE DATA (1)

SIZE	DIMENSIONS AND PERFORMANCE DATA (1)												
	in	2	2 1/2	3	4	5	6	8	10	12	14	16	20
A DIMENSION (2) FACE TO FACE	in	8.625	7.562	8.75	11.25	12.25	14.00	17.125	22.00	25.25	29.00	31.875	36.49
	mm	220	193	223	286	311	356	435	559	642	737	810	927
B DIMENSION (3) CTR. LINE TO BOTTOM	in	4.88	5.12	4.63	7.00	7.88	8.00	11.38	14.12	20.25	30.00	36.66	38.44
	mm	124	130	118	178	200	204	289	359	515	762	931	976
C DIMENSION CTR. LINE TO TOP	in	3.83	3.75	5.125	5.375	4.75	7.00	8.00	8.82	10.32	15.00	16.00	15.75
	mm	97	96	131	137	121	178	203	224	262	381	406	400
D DIMENSION NPT BLOW-OFF	in	1/2	3/4	3/4	1	1	1 1/4	1 1/2	1 1/2	2	2	2	2
	mm	15	20	20	25	25	32	40	40	50	50	50	50
E DIMENSION SCREEN REMOVAL	in	10.875	10.875	11.25	15.50	15.50	18.25	23.375	27.50	35.00	45.00	55.00	65.00
	mm	277	277	286	394	394	464	594	699	889	1143	1397	1651
ASSEMBLED WEIGHT (BS65)	lb	27.0	30.0	40.0	64.0	84.0	142.0	244.0	416.0	732.0	992	1735	C/F
	kg	12.2	13.6	18.1	29.0	38.1	64.4	110.6	188.5	332.0	450.0	787.0	C/F
ASSEMBLED WEIGHT (BS55)	lb	31.0	34.0	42.0	81.0	84.0	150.0	275.0	436.8	768.0	1246	C/F	C/F
	kg	14.0	15.4	19.0	36.7	38.1	68.0	124.7	197.8	348.4	565.2	C/F	C/F
Flow Coefficient	C _v	45	90	140	290	500	800	1600	2800	3700	5100	6800	10900

- Dimensions, weights, and flow coefficients are provided for reference only. When required request certified drawings.
- Face to face values have a tolerance of ±0.06 in (±2.0 mm) for sizes 10" and lower and a tolerance of ±0.12 in (±3.0 mm) for sizes 12" and larger.
- Removable/adjustable leg brackets are standard on sizes 8" through 20". Centerline to bottom dimension does not include removable legs, which can extend approximately three to five inches beyond the bottom boss drain.

Additional Design & Technical Notes:

- Inlet and outlet bosses are standard on sizes 8" through 14".
- Inlet and outlet 1/4" NPT gauge taps with plugs are standard on sizes 2" through 20".
- 1/4" cover vent taps with plugs are standard on sizes 8" through 20".
- Straining element features a bow shaped handle that presses against the cover to help ensure the straining element remains securely seated during operation.
- Clamped cover design: Sizes 2" ~ 4" are designed with (1) Tee Bolt Size 6" is designed with (2) Tee Bolts Sizes 8" ~ 16" are designed with (4) Tee Bolts Size 20" is designed with (6) Tee Bolts

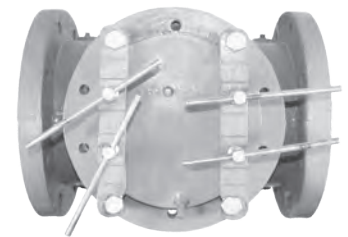

PRESSURE - TEMPERATURE RATINGS

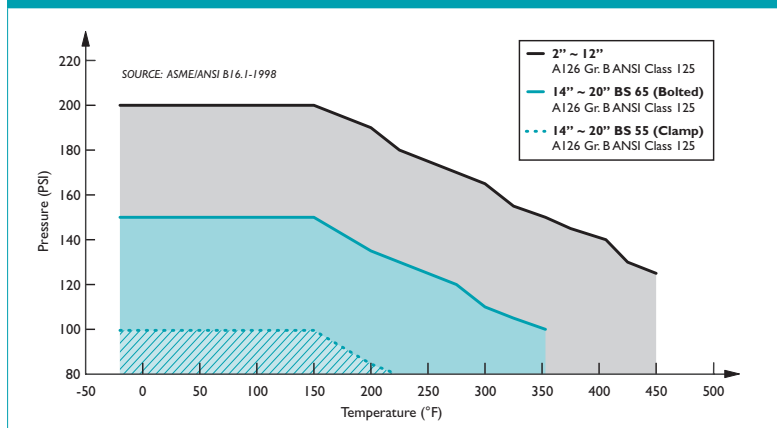

PRESSURE - TEMPERATURE RATING

ANSI CLASS 125	BS 65-CI (2 ~ 12")	BS 55-CI (2 ~ 12")
WOG (Non-shock)	200 PSI @ 150 °F	200 PSI @ 100 °F
ANSI CLASS 125	BS 65-CI (14 ~ 20")	BS 55-CI (14 ~ 20")
WOG (Non-shock)	150 PSI @ 150 °F	100 PSI @ 100 °F

REFERENCED STANDARDS & CODES

CODE	DESCRIPTION
ASME/ANSI B16.1	Cast Iron Pipe Flanges and Flanged Fittings

Titan FCI makes every effort to ensure the information presented on our literature accurately reflects exact product specifications. However, as product changes occur, there may be short-term differences between actual product specifications and the information contained within our literature. Titan FCI reserves the right to make design and specification changes to improve our products without prior notification. When required, request certified drawings.

SIMPLEX BASKET STRAINER ♦ FLANGED ENDS (RF)

ANSI CLASS 150 ♦ CARBON AND STAINLESS STEEL

MODELS: BS 85-CS
(CARBON STEEL)

BS 85-SS
(STAINLESS STEEL)

SIZES: 2" ~ 12"

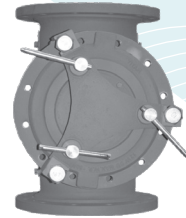

Quick-opening
clamp cover option
is also available.
Quick-opening clamp
cover rated at 200 PSI.



FEATURES

- ♦ **HIGH QUALITY DESIGN**
THE BS85 BASKET STRAINER BOASTS MANY UNIQUE DESIGN FEATURES INCLUDING: INLET/OUTLET BOSSES WITH GAUGE TAPS (2" AND UP), SPOT-FACED FLANGE BOLT HOLES, PLUGGED BOTTOM DRAIN AND COVER VENT, CAST-IN SUPPORT LEGS (6" AND UP), EPOXY PAINTED CARBON BODIES, ENCAPSULATED COVER GASKET, AND AN OPTIONAL QUICK-OPENING COVER DESIGN.
- ♦ **MINIMAL PRESSURE LOSS**
PRESSURE LOSS IS MINIMIZED BY PROVIDING A SLANTED STRAINING ELEMENT DESIGN AND STRAIGHT FLOW PATH. PLUGGED, NPT TAPS ARE PROVIDED (NEAR THE INLET AND OUTLET ON BOTH SIDES) ALLOWING FOR THE QUICK MOUNTING OF PRESSURE GAUGES TO MONITOR PRESSURE LOSS.
- ♦ **LARGE STRAINING CAPACITY**
WITH ITS LARGE BODY AND SIZEABLE STRAINING ELEMENT, THE BS 85-CS/SS HAS THE ABILITY TO STORE LARGE QUANTITIES OF DEBRIS WITHOUT AFFECTING PRESSURE LOSS - THUS MAXIMIZING TIME BETWEEN SERVICING.
- ♦ **NUMEROUS STRAINING ELEMENT OPTIONS**
STRAINING ELEMENTS ARE AVAILABLE IN A VARIETY OF PERFORATIONS, MESHES, AND MATERIALS. SPECIAL DESIGNS ARE ALSO AVAILABLE INCLUDING MAGNETIC, WEDGE WIRE, DRILLED PERFORATIONS, AND PLEATED STRAINING ELEMENTS. THE STANDARD MATERIAL FOR STRAINING ELEMENTS IS TYPE 304 STAINLESS STEEL.
- ♦ **SELF-CLEANING OPTION**
UTILIZING A MODIFIED STRAINING ELEMENT, THE BOTTOM DRAIN CAN BE FITTED WITH A TITAN FCI BALL VALVE TO ALLOW FOR THE AUTOMATIC CLEANING OR FLUSHING OF THE STRAINING ELEMENT WHILE KEEPING THE PIPELINE IN SERVICE.

TECHNICAL

PRESSURE/TEMPERATURE RATING
CS - ASTM A216 GR. WCB - CLASS 150

WOG (Non-shock): 285 PSI @ 100 °F

PRESSURE/TEMPERATURE RATING
SS - ASTM A351 GR. CF8M - CLASS 150

WOG (Non-shock): 275 PSI @ 100 °F

- Carbon Steel not recommended for prolonged use above 800 °F
- Stainless Steel not recommended for prolonged use above 1000 °F.

APPLICATIONS

MARKETS: WATER & WASTEWATER, PULP & PAPER, CHEMICAL & PETROCHEMICAL, PETROLEUM, OIL & GAS, TRANSPORTATION, MARINE INDUSTRY, AND FOOD INDUSTRY

GENERAL APPLICATION: SIMPLEX BASKET STRAINERS ARE INSTALLED INTO A PIPELINE SYSTEM TO REMOVE UNWANTED DEBRIS FROM THE PIPELINE FLOW. BASKET STRAINERS ARE COMMONLY USED IN HORIZONTAL PIPELINES WHERE DEBRIS LOADING IS HIGH AND THE COLLECTION OF SOLIDS IS REQUIRED. STRAINING IS ACCOMPLISHED VIA A PERFORATED OR MESH LINED STRAINING ELEMENT, INTERNAL TO THE BASKET STRAINER. IN GENERAL, THE SIZE OF THE PERFORATION OR MESH SHOULD BE SLIGHTLY SMALLER THAN THE SMALLEST DEBRIS PARTICLE TO BE REMOVED. IT IS IMPORTANT TO NOTE THAT THE CORRECT SIZE OF A BASKET STRAINER IS DETERMINED BY ITS JOB FUNCTION, NOT BY THE SIZE OF THE PIPELINE.

The above data represents common market and service applications. No representation or guarantee, expressed or implied, is given due to the numerous variations of concentrations, temperatures and flow conditions that may occur during actual service.

TITAN FLOW CONTROL, INC.
YOUR PIPELINE TO THE FUTURE!

Tel: 910-735-0000 ♦ Fax: 910-738-3848 ♦ titan@titanfci.com ♦ www.titanfci.com
290 Corporate Drive ♦ PO Box 7408 ♦ Lumberton, NC 28358



TITAN FLOW CONTROL, Inc.

290 Corporate Drive
Lumberton, NC 28358
Tel: 910.735.0000

E-mail: titan@titanfci.com
Web: www.titanfci.com
Fax: 910.738.3848

SIMPLEX BASKET STRAINER

BS 85-CS - (Carbon Steel)
BS 85-SS - (Stainless Steel)

Flanged Ends • Raised Face • Carbon & Stainless Steel

**ANSI
Class 150**

BILL OF MATERIALS ⁽¹⁾

No.	PART	BS 85-CS ⁽²⁾	BS 85-SS
1	Body	Carbon Steel A216 Gr.WCB	Stainless Steel A351 Gr. CF8M
2	Cover ⁽⁴⁾	Carbon Steel A216 Gr.WCB	Stainless Steel A351 Gr. CF8M
3	Cover Gasket ^{(3) (4) (6)}	Bolted Cover: Spiral Wound Stainless Steel Non-Asbestos Clamp Cover (Optional): Buna-N O-Ring	
4	Straining Element ^{(3) (5)}	Type 304 Stainless Steel (Other materials are available)	
5	Stud	Alloy Steel A193-B7	Stainless Steel 18-8 Series 300
6	Nut	Carbon Steel A194-2H	Stainless Steel 18-8 Series 300
7	Plug	Carbon Steel	Stainless Steel

- Equivalent or better materials may be substituted at the manufacturer's discretion.
- Carbon Steel bodies are epoxy painted.
- Denotes recommended spare parts.
- Bolted cover is shown. For information on clamp cover, please contact factory.
- Straining element on 2" BS 85 is a straight screen. It is not diagonal as illustrated on right.
- Carbon Fiber Compressed gasket may be substituted at the manufacturer's discretion.

Body Material Application Notes:

- Carbon Steel performs exceptionally well in high temperatures, up to 800 °F in continuous service. It provides high resistance to shock, vibration, piping strains, and fire and freezing hazards. Carbon Steel strainers are often used in the oil and petrochemical industries.
- Stainless Steel is highly corrosion resistant, extremely strong, and is commonly specified for high temperature service, up to 1000 °F in continuous service. Stainless Steel strainers are commonly found in the chemical, food, and pharmaceutical industries.

Bolted cover is shown.
Quick-opening clamp cover rated at 200 PSI is also available.

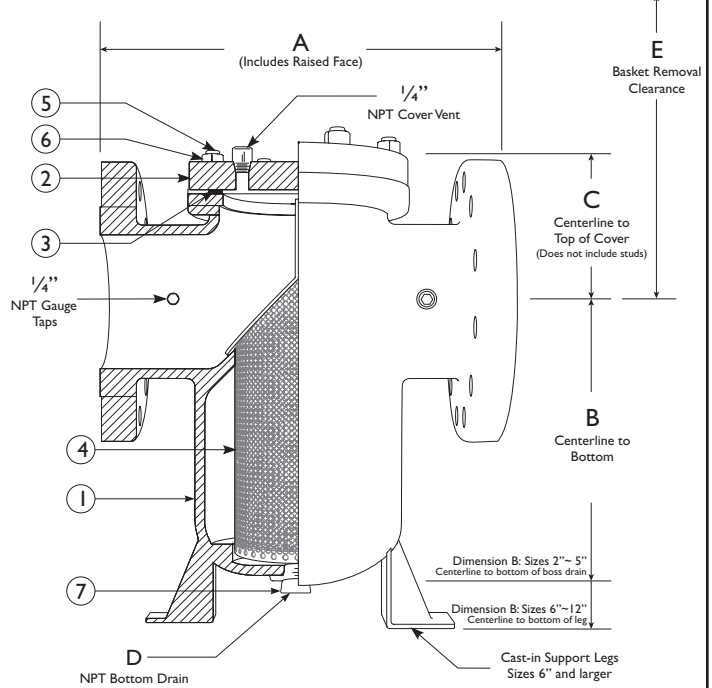

DIMENSIONS AND PERFORMANCE DATA ⁽¹⁾

SIZE	in	2	2 1/2	3	4	5	6	8	10	12
	mm	50	65	80	100	125	150	200	250	300
A DIMENSION FACE TO FACE	in	8.50	8.00	8.75	11.187	C/F	13.875	17.375	22.00	26.25
	mm	216	204	223	285	C/F	353	442	559	667
B DIMENSION CTR. LINE TO BOTTOM	in	5.875	5.437	5.25	7.875	C/F	13.125	16.375	18.25	18.75
	mm	150	139	134	201	C/F	334	416	464	476
C DIMENSION CTR. LINE TO TOP	in	5.00	4.75	5.50	6.125	C/F	6.75	8.875	10.75	13.75
	mm	127	121	140	156	C/F	172	226	274	350
D DIMENSION NPT BLOW-OFF	in	.50	.75	.75	1.00	C/F	1.25	1.50	1.50	2.00
	mm	15	20	20	25	C/F	32	40	40	50
E DIMENSION SCREEN REMOVAL	in	10.875	10.187	10.75	14.0	C/F	19.875	25.25	30.125	37.5
	mm	276	259	273	356	C/F	505	641	765	953
ASSEMBLED WEIGHT APPROXIMATE	lb	27.0	33.0	38.0	64.0	89.0	128.0	227.0	362.0	487.0
	kg	12.2	15.0	17.2	29.0	40.4	58.0	102.9	164.0	220.7
Flow Coefficient	C _v	45	90	140	290	500	800	1600	2800	3700

- Dimensions, weights, and flow coefficients are provided for reference only. When required, always request certified drawings.
- Face to face values have a tolerance of ±0.06 in (±2.0 mm) for sizes 10" and lower and a tolerance of ±0.12 in (±3.0 mm) for sizes 12" and larger.

Additional Design & Technical Notes:

- Cover vent is provided on all sizes. Cover vent is 1/4" NPT on all sizes and is furnished with plug.
- Bottom drain is furnished with plug. See table to the left for sizes.
- Plugged 1/4" NPT gauge taps (inlet and outlet) are provided on sizes 2" and larger.
- Cast-in support legs are provided on sizes 6" and larger.
- Optional cover designs are available - C/F.
- Steam jacketed designs are available - C/F.
- Epoxy coating is available - C/F.
- Designed for horizontal pipelines only.
- Standard material for straining elements is Type 304 Stainless Steel. Other materials are available upon request.

PRESSURE - TEMPERATURE RATING

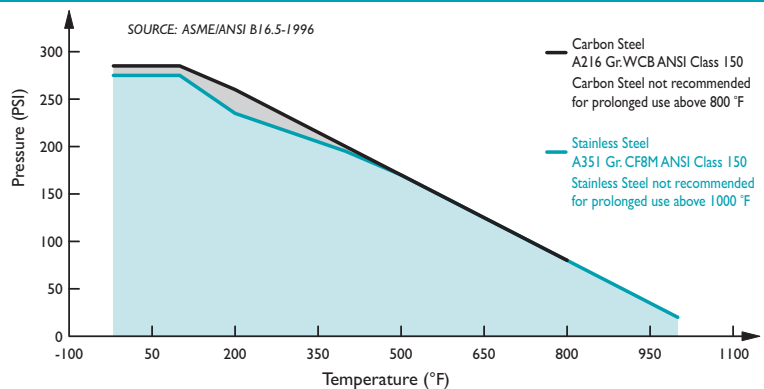

REFERENCED STANDARDS & CODES

CODE	DESCRIPTION
ASME/ANSI B16.5	Pipe Flanges and Flanged Fittings
ANSI/MSS SP-55	Quality Standard - Visual Inspection

PRESSURE - TEMPERATURE RATING

ANSI CLASS 150	A216 Gr.WCB	A351 Gr. CF8M
WOG (Non-shock)	285 PSI @ 100 °F	275 PSI @ 100 °F

STANDARD SCREEN SELECTIONS

Size	Liquid	Open Area	Steam	Open Area
2" ~ 4"	1/16 (.0625)	41%	3/64 (.045)	36%
5" ~ 12"	1/8 (.125)	40%	30 Mesh Ln. ⁽¹⁾	44.8 %

1. For 10" and above, consult factory on screen selections for steam.



TITAN FLOW CONTROL, INC.

SIMPLEX BASKET STRAINER ♦ FLANGED ENDS (FF)

ANSI CLASS 150 ♦ ALUMINUM BRONZE ♦ LEAD FREE*

Meets LEAD-FREE⁽¹⁾ requirements!



FEATURES

MODEL: **BS 95-AB**
(ALUMINUM BRONZE)
SIZES: 2" ~ 12"

- ◇ **ASTM B148 BODY MATERIAL**
ALUMINUM BRONZE IS STRONGER AND LESS LIKELY TO CORRODE THAN OTHER BRONZE ALLOYS, MAKING IT A PREFERRED CHOICE FOR SEA WATER AND OTHER APPLICATIONS WHERE CORROSION IS A CONCERN. BECAUSE OF ITS COPPER CONTENT, MARINE ORGANISMS CANNOT COLONIZE ON THE MATERIAL. ADDITIONALLY, TITAN'S BS95-AB IS USED FOR POTABLE WATER APPLICATIONS AS IT MEETS LEAD FREE STATUTES REQUIRING THAT THE LEAD CONTENT IN THE WETTED SURFACES IS 0.25% OR LESS AS DETERMINED BY A WEIGHTED AVERAGE.
- ◇ **HIGH QUALITY DESIGN**
THE BS95 BASKET STRAINER BOASTS MANY UNIQUE DESIGN FEATURES INCLUDING: INLET/OUTLET BOSSES WITH GAUGE TAPS (6" AND UP), SPOT-FACED FLANGE BOLT HOLES, PLUGGED BOTTOM DRAIN AND COVER VENT, CAST-IN SUPPORT LEGS (6" AND UP), ENCAPSULATED COVER GASKET, AND AN OPTIONAL QUICK-OPENING COVER DESIGN.
- ◇ **MINIMAL PRESSURE LOSS**
PRESSURE LOSS IS MINIMIZED BY PROVIDING A SLANTED STRAINING ELEMENT DESIGN (SIZES 2½" AND UP) AND STRAIGHT FLOW PATH. PLUGGED, NPT TAPS ARE PROVIDED (NEAR THE INLET AND OUTLET ON BOTH SIDES OF SIZES 6" AND UP) ALLOWING FOR THE QUICK MOUNTING OF PRESSURE GAUGES TO MONITOR PRESSURE LOSS.
- ◇ **LARGE STRAINING CAPACITY**
WITH ITS LARGE BODY AND SIZEABLE STRAINING ELEMENT, THE BS 95-AB HAS THE ABILITY TO STORE LARGE QUANTITIES OF DEBRIS WITHOUT AFFECTING PRESSURE LOSS - THUS MAXIMIZING TIME BETWEEN SERVICING.
- ◇ **NUMEROUS STRAINING ELEMENT OPTIONS**
STRAINING ELEMENTS ARE AVAILABLE IN A VARIETY OF PERFORATIONS, MESHES, AND MATERIALS. SPECIAL DESIGNS ARE ALSO AVAILABLE INCLUDING MAGNETIC, WEDGE WIRE, DRILLED PERFORATIONS, AND PLEATED STRAINING ELEMENTS. THE STANDARD MATERIAL FOR STRAINING ELEMENTS IS TYPE 304 STAINLESS STEEL.

TECHNICAL

PRESSURE/TEMPERATURE RATING⁽²⁾
AB - ASTM B148 GR. 9D - CLASS 150

WOG (Non-shock): 225 PSI @ 150 °F

1. The BS 95-AB meets requirements for lead free use in potable water systems. The lead content in the wetted surfaces is 0.25% or less as determined by a weighted average. For more information on lead free requirements, contact Titan Flow Control.
2. The above listed temperatures are theoretical and may vary during actual operating conditions. These ratings are based on ANSI B16.24 for ASTM B62. The body material of the BS 95 is Aluminum Bronze B148 which may slightly exceed these ratings.

APPLICATIONS

MARKETS: POTABLE WATER, WATER & WASTEWATER, PULP & PAPER, CHEMICAL & PETROCHEMICAL, PETROLEUM, OIL & GAS, TRANSPORTATION, GOVERNMENT, MARINE INDUSTRY (SEAWATER), AND FOOD INDUSTRY

GENERAL APPLICATION: SIMPLEX BASKET STRAINERS ARE INSTALLED INTO A PIPELINE SYSTEM TO REMOVE UNWANTED DEBRIS FROM THE PIPELINE FLOW. BASKET STRAINERS ARE COMMONLY USED IN HORIZONTAL PIPELINES WHERE DEBRIS LOADING IS HIGH AND THE COLLECTION OF SOLIDS IS REQUIRED. STRAINING IS ACCOMPLISHED VIA A PERFORATED OR MESH LINED STRAINING ELEMENT, INTERNAL TO THE BASKET STRAINER. IN GENERAL, THE SIZE OF THE PERFORATION OR MESH SHOULD BE SLIGHTLY SMALLER THAN THE SMALLEST DEBRIS PARTICLE TO BE REMOVED. IT IS IMPORTANT TO NOTE THAT THE CORRECT SIZE OF A BASKET STRAINER IS DETERMINED BY ITS JOB FUNCTION, NOT BY THE SIZE OF THE PIPELINE.

The above data represents common market and service applications. No representation or guarantee, expressed or implied, is given due to the numerous variations of concentrations, temperatures and flow conditions that may occur during actual service.

TITAN FLOW CONTROL, INC.

YOUR PIPELINE TO THE FUTURE!

Tel: 910-735-0000 ♦ Fax: 910-738-3848 ♦ titan@titanfci.com ♦ www.titanfci.com
290 Corporate Drive ♦ PO Box 7408 ♦ Lumberton, NC 28358



TITAN FLOW CONTROL, Inc.
 290 Corporate Drive
 Lumberton, NC 28358
 Tel: 910.735.0000
 E-mail: titan@titanfci.com
 Web: www.titanfci.com
 Fax: 910.738.3848

SIMPLEX BASKET STRAINER
BS 95-AB - (Aluminum Bronze)
 Flanged Ends • Flat Face • Aluminum Bronze

ANSI
 Class 150

BILL OF MATERIALS (1)

No.	PART	BS 95-AB
1	Body	Aluminum Bronze ASTM B148
2	Cover (3)	Aluminum Bronze ASTM B148
3	Cover Gasket (2) (3) (6)	PTFE
4	Straining Element (2)	Type 304 Stainless Steel (Other materials are available)
5	Hex Bolt (4)	Silicon Bronze
6	Plug	Stainless Steel (5)

- Equivalent or better materials may be substituted at the manufacturer's discretion.
- Denotes recommended spare parts.
- Bolted cover is shown. For information on clamp cover, please contact factory.
- 302 stainless steel bolts are available.
- NPT Plug also available in other materials.
- Carbon Fiber Compressed gasket may be substituted at the manufacturer's discretion.

Body Material Application Notes:

- Aluminum Bronze (ASTM B148) is a preferred material for lead-free basket strainers, meeting requirements for potable water systems by containing 0.25% lead or less by average weight on all wetted parts of the strainers.
- Aluminum Bronze is strong and corrosion resistant, meeting the needs of many various applications, such as seawater and marine.

Additional Design & Technical Notes:

- Cover vent, provided on all sizes, is 1/4" NPT is furnished with plug.
- Bottom drain is furnished with plug. See table to the right for sizes.
- Plugged 1/4" NPT gauge taps (inlet and outlet) are provided on sizes 6" and larger.
- Cast-in support legs are provided on sizes 6" and larger.
- Slanted screen is provided on sizes 2 1/2" and up; 2" sizes have straight screen.
- Optional cover designs, steam jacketed designs and epoxy coatings are available.
- Standard material for straining elements is Type 304 Stainless Steel. Other materials are available upon request.
- Designed for horizontal pipelines only.

Bolted cover is shown. Full rated, quick-opening, clamp cover is also available. Illustration is representative of sizes 6" through 12". Please ask for certified drawings when required.

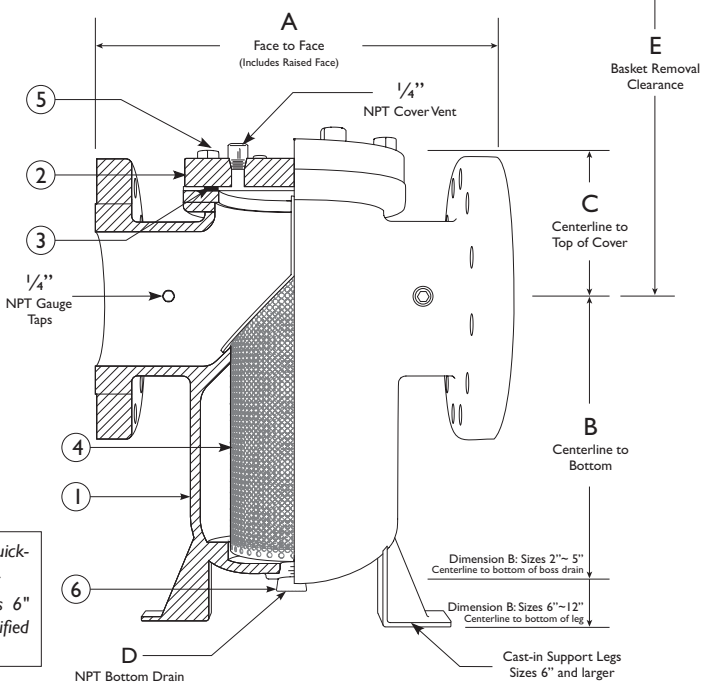

DIMENSIONS AND PERFORMANCE DATA (1)

SIZE	in	2	2 1/2	3	4	5	6	8	10	12
	mm	50	65	80	100	125	150	200	250	300
A DIMENSION FACE TO FACE (2)	in	8.50	C/F	8.75	11.187	C/F	13.875	17.375	C/F	C/F
	mm	216	C/F	222	285	C/F	353	442	C/F	C/F
B DIMENSION CTR. LINE TO BOTTOM	in	5.875	C/F	5.25	7.875	C/F	11.5	15.0	C/F	C/F
	mm	150	C/F	134	201	C/F	294	382	C/F	C/F
C DIMENSION CTR. LINE TO TOP	in	5.00	C/F	5.50	6.125	C/F	6.75	8.5	C/F	C/F
	mm	127	C/F	140	156	C/F	172	215	C/F	C/F
D DIMENSION NPT BLOW-OFF	in	.50	C/F	.75	1.00	C/F	1.25	1.50	C/F	C/F
	mm	15	C/F	20	25	C/F	32	40	C/F	C/F
E DIMENSION SCREEN REMOVAL	in	11.00	C/F	11.625	15.312	C/F	18.875	25.0	C/F	C/F
	mm	280	C/F	295	390	C/F	480	635	C/F	C/F
ASSEMBLED WEIGHT APPROXIMATE	lb	24.0	C/F	38.0	64.0	C/F	128.0	227.0	C/F	C/F
	kg	10.9	C/F	17.2	29.0	C/F	58.0	102.9	C/F	C/F
Flow Coefficient	C _v	45	90	140	290	500	800	1600	2800	3700

- Dimensions, weights, and flow coefficients are provided for reference only. When required, always request certified drawings.
- Face to face values have a tolerance of ±0.06 in (±2.0 mm) for sizes 10" and lower and a tolerance of ±0.12 in (±3.0 mm) for sizes 12" and larger.

PRESSURE - TEMPERATURE RATING (1)

ANSI CLASS 150

AB - B148

WOG (Non-shock)

225 PSI @ 150 °F

- Pressure - Temperature Ratings are provided for a general reference. They are based on ANSI B16.24 for ASTM B62. The body material of the BS 95 is Aluminum Bronze B148 which may slightly exceed these ratings.

REFERENCED STANDARDS & CODES

CODE	DESCRIPTION
ASME/ANSI B16.24	Cast Copper Alloy Pipe Flanges and Flanged Fittings

STANDARD SCREEN SELECTIONS

Size	Liquid	Open Area	Steam	Open Area
2" ~ 4"	1/16 (.0625)	41%	3/64 (.045)	36%
5" ~ 12"	1/8 (.125)	40%	30 Mesh(1)	44.8 %

- For 10" and above, consult factory on screen selections for steam.

PRESSURE - TEMPERATURE RATING

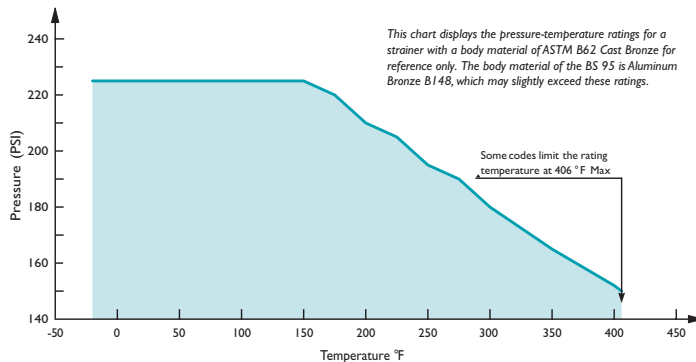

Titan FCI makes every effort to ensure the information presented on our literature accurately reflects exact product specifications. However, as product changes occur, there may be short-term differences between actual product specifications and the information contained within our literature. Titan FCI reserves the right to make design and specification changes to improve our products without prior notification. When required, request certified drawings.



SIMPLEX BASKET STRAINER ♦ FLANGED ENDS

ANSI CLASS 300 ♦ CARBON AND STAINLESS STEEL

MODELS: BS 86-CS
(CARBON STEEL)

BS 86-SS
(STAINLESS STEEL)

SIZES: 2" ~ 12"

FEATURES

- ♦ **RUGGED, HIGH QUALITY CONSTRUCTION**
THE MODEL BS 86-CS/SS IS A HEAVY DUTY BASKET STRAINER DESIGNED WITH EXCEPTIONAL WALL THICKNESS. IT IS AVAILABLE IN BOTH CARBON STEEL AND STAINLESS STEEL. IT IS A LOGICAL CHOICE FOR SERVICE APPLICATIONS THAT HAVE HIGHER TEMPERATURE AND PRESSURE REQUIREMENTS.
- ♦ **MINIMAL PRESSURE LOSS**
PRESSURE LOSS IS MINIMIZED BY PROVIDING A SLANTED STRAINING ELEMENT DESIGN AND STRAIGHT FLOW PATH. PLUGGED, NPT TAPS ARE PROVIDED (NEAR THE INLET AND OUTLET ON BOTH SIDES) ALLOWING FOR THE QUICK MOUNTING OF PRESSURE GAUGES TO MONITOR PRESSURE LOSS.
- ♦ **LARGE STRAINING CAPACITY**
WITH ITS LARGE BODY AND SIZEABLE STRAINING ELEMENT, THE BS 86-CS/SS HAS THE ABILITY TO STORE LARGE QUANTITIES OF DEBRIS WITHOUT AFFECTING PRESSURE LOSS - THUS MAXIMIZING TIME BETWEEN SERVICING.
- ♦ **NUMEROUS STRAINING ELEMENT OPTIONS**
STRAINING ELEMENTS ARE AVAILABLE IN A VARIETY OF PERFORATIONS, MESHES, AND MATERIALS. SPECIAL DESIGNS ARE ALSO AVAILABLE INCLUDING MAGNETIC, WEDGE WIRE, DRILLED PERFORATIONS, AND PLEATED STRAINING ELEMENTS. THE STANDARD MATERIAL FOR STRAINING ELEMENTS IS TYPE 304 STAINLESS STEEL.
- ♦ **SELF-CLEANING OPTION**
UTILIZING A MODIFIED STRAINING ELEMENT, THE BOTTOM DRAIN CAN BE FITTED WITH A TITAN FCI BALL VALVE TO ALLOW FOR THE AUTOMATIC CLEANING OR FLUSHING OF THE STRAINING ELEMENT WHILE KEEPING THE PIPELINE IN SERVICE.



TECHNICAL

PRESSURE/TEMPERATURE RATING
CS - ASTM A216 GR. WCB - CLASS 300

WOG (Non-shock): 740 PSI @ 100 °F

PRESSURE/TEMPERATURE RATING
SS - ASTM A351 GR. CF8M - CLASS 300

WOG (Non-shock): 720 PSI @ 100 °F

- Carbon Steel not recommended for prolonged use above 800 °F.
- Stainless Steel not recommended for prolonged use above 1000 °F.

APPLICATIONS

MARKETS: WATER & WASTEWATER, PULP & PAPER, CHEMICAL & PETROCHEMICAL, PETROLEUM, OIL & GAS, TRANSPORTATION, MARINE INDUSTRY, AND FOOD INDUSTRY

GENERAL APPLICATION: SIMPLEX BASKET STRAINERS ARE INSTALLED INTO A PIPELINE SYSTEM TO REMOVE UNWANTED DEBRIS FROM THE PIPELINE FLOW. BASKET STRAINERS ARE COMMONLY USED IN HORIZONTAL PIPELINES WHERE DEBRIS LOADING IS HIGH AND THE COLLECTION OF SOLIDS IS REQUIRED. STRAINING IS ACCOMPLISHED VIA A PERFORATED OR MESH LINED STRAINING ELEMENT, INTERNAL TO THE BASKET STRAINER. IN GENERAL, THE SIZE OF THE PERFORATION OR MESH SHOULD BE SLIGHTLY SMALLER THAN THE SMALLEST DEBRIS PARTICLE TO BE REMOVED. IT IS IMPORTANT TO NOTE THAT THE CORRECT SIZE OF A BASKET STRAINER IS DETERMINED BY ITS JOB FUNCTION, NOT BY THE SIZE OF THE PIPELINE.

The above data represents common market and service applications. No representation or guarantee, expressed or implied, is given due to the numerous variations of concentrations, temperatures and flow conditions that may occur during actual service.

TITAN FLOW CONTROL, INC.
YOUR PIPELINE TO THE FUTURE!

Tel: 910-735-0000 ♦ Fax: 910-738-3848 ♦ titan@titanfci.com ♦ www.titanfci.com
290 Corporate Drive ♦ PO Box 7408 ♦ Lumberton, NC 28358



TITAN FLOW CONTROL, Inc.

290 Corporate Drive
Lumberton, NC 28358
Tel: 910.735.0000

E-mail: titan@titanfci.com
Web: www.titanfci.com
Fax: 910.738.3848

SIMPLEX BASKET STRAINER

BS 86-CS - (Carbon Steel)
BS 86-SS - (Stainless Steel)

Flanged Ends • Raised Face • Carbon & Stainless Steel

ANSI Class
300

BILL OF MATERIALS (1)

No.	PART	BS 86-CS (2)	BS 86-SS
1	Body	Carbon Steel A216 Gr.WCB	Stainless Steel A351 Gr. CF8M
2	Cover	Carbon Steel A216 Gr.WCB	Stainless Steel A351 Gr. CF8M
3	Cover Gasket (3)(4)(6)	Spiral Wound Stainless Steel Non-Asbestos	
4	Straining (3) Element	Type 304 Stainless Steel (Other materials are available)	
5	Stud	Alloy Steel A193-B7	Stainless Steel 18-8 Series 300
6	Nut	Carbon Steel A194-2H	Stainless Steel 18-8 Series 300
7	Plug	Carbon Steel	Stainless Steel

1. Equivalent or better materials may be substituted at the manufacturer's discretion.
2. Carbon Steel bodies are epoxy painted.
3. Denotes recommended spare parts.
4. Gasket is for bolted cover. For special cover designs, different gasket may be used.
6. Carbon Fiber Compressed gasket may be substituted at the manufacturer's discretion.

Body Material Application Notes:

- Carbon Steel performs exceptionally well in high temperatures, up to 800 °F in continuous service. It provides high resistance to shock, vibration, piping strains, and fire and freezing hazards. Carbon Steel strainers are often used in the oil and petrochemical industries.
- Stainless Steel is highly corrosion resistant, extremely strong, and is commonly specified for high temperature service, up to 1000 °F in continuous service. Stainless Steel strainers are commonly found in the chemical, food, and pharmaceutical industries.

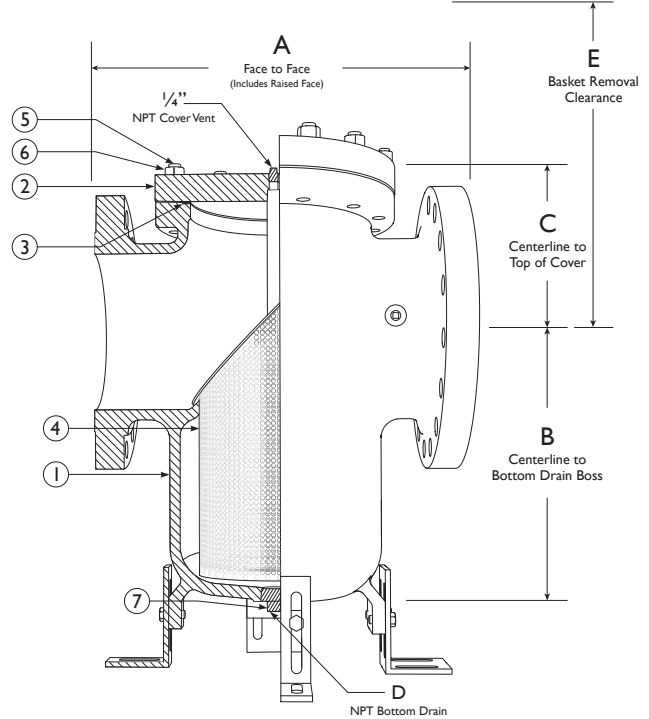

DIMENSIONS AND PERFORMANCE DATA (1)

SIZE	in	2	2 1/2	3	4	5	6	8	10	12	
	mm	50	65	80	100	125	150	200	250	300	
A DIMENSION FACE TO FACE (2)	in	8.50	8.69	9.56	11.75	C/F	14.75	18.13	22.88	25.38	
	mm	216	221	243	302	C/F	375	461	582	645	
B DIMENSION CTR. LINE TO BOTTOM	in	6.14	6.25	8.25	8.62	C/F	12.75	15.51	17.13	24.92	
	mm	156	159	210	219	C/F	324	394	435	633	
C DIMENSION CTR. LINE TO TOP	in	4.91	5.45	6.08	5.31	C/F	6.38	8.09	9.70	11.70	
	mm	125	139	155	135	C/F	162	206	247	298	
D DIMENSION NPT BLOW-OFF	in	.50	.75	.75	1.00	C/F	1.25	1.50	1.50	2.00	
	mm	15	20	20	25	C/F	32	40	40	50	
E DIMENSION SCREEN REMOVAL	in	9.00	10.00	10.00	10.00	C/F	20.00	20.00	26.00	35.00	
	mm	229	254	254	254	C/F	508	508	661	889	
ASSEMBLED WEIGHT APPROXIMATE	lb	40.0	63.0	63.0	108.0	C/F	200.0	342.0	542.0	946.0	
	kg	18.1	28.5	28.5	48.9	C/F	90.6	155.0	245.6	429.1	
Flow Coefficient	C _v	45	90	140	290		500	800	1600	2800	3700

1. Dimensions, weights, and flow coefficients are provided for reference only. When required, always request certified drawings.
2. Face to face values have a tolerance of ±0.06 in (±2.0 mm) for sizes 10" and lower and a tolerance of ±0.12 in (±3.0 mm) for sizes 12" and larger.

PRESSURE - TEMPERATURE RATINGS

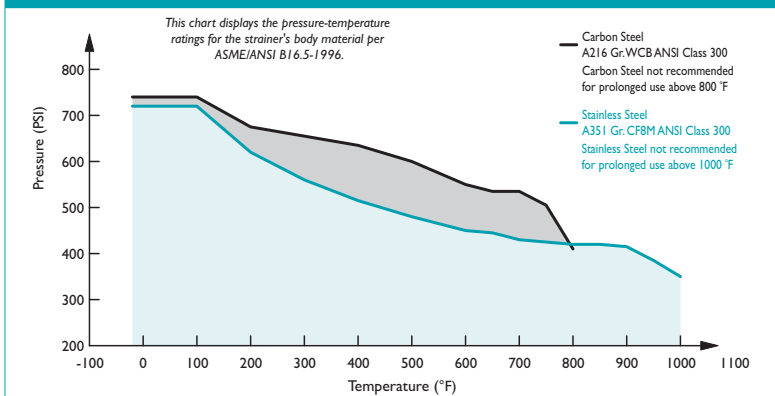

Additional Design & Technical Notes:

- Cover vent provided on all sizes. Cover vent is 1/4" NPT on all sizes and is furnished with plug.
- Bottom drain is furnished with plug. See table to the left for sizes
- 1/4" NPT gauge taps are provided on all sizes and are furnished with plugs.
- Adjustable/Removable Support legs are provided on sizes 4" and larger.
- Optional cover designs are available - C/F.
- Steam jacketed designs are available - C/F.
- Epoxy coating is available - C/F.
- Designed for horizontal pipelines only.
- Standard material for straining elements is Type 304 Stainless Steel. Other materials are available upon request.

REFERENCED STANDARDS & CODES

CODE	DESCRIPTION
ASME/ANSI B16.5	Pipe Flanges and Flanged Fittings
ANSI/MSS SP-55	Quality Standard - Visual Inspection

PRESSURE - TEMPERATURE RATING

ANSI CLASS 300	A216 Gr.WCB	A351 Gr. CF8M
WOG (Non-shock)	740 PSI @ 100 °F	720 PSI @ 100 °F

STANDARD SCREEN SELECTIONS

Size	Liquid	Open Area	Steam	Open Area
2" ~ 4"	1/16 (.0625)	41%	3/64 (.045)	36%
5" ~ 12"	1/8 (.125)	40%	30 Mesh (1)	44.8 %

1. For 10" and above, consult factory on screen selections for steam.

Titan FCI makes every effort to ensure the information presented on our literature accurately reflects exact product specifications. However, as product changes occur, there may be short-term differences between actual product specifications and the information contained within our literature. Titan FCI reserves the right to make design and specification changes to improve our products without prior notification. When required, request certified drawings.



TITAN FLOW CONTROL, INC.

SIMPLEX BASKET STRAINER ♦ ANSI CLASS 150 FLAT FACE FIBERGLASS REINFORCED PLASTIC (FRP)

MODELS: BS 55-FRP
(FIBERGLASS)

SIZES: 4" ~ 20"



Quick-opening
knob cover is rated
at 50 PSI.

Bolted cover is rated
at 150 PSI.

FEATURES

- ♦ **STANDARD GRADE FRP DESIGNED FOR COMMERCIAL SYSTEMS**
FOR LOW PRESSURE/TEMPERATURE APPLICATIONS, TITAN FCI OFFERS OUR STANDARD GRADE FRP STRAINER CONSTRUCTED FROM ISOPHTHALIC POLYESTER WITH STAINLESS STEEL BASKET INSERTS. PRESSURE TESTED TO 75 PSI. FLANGED CONNECTIONS ARE DRILLED TO 150 LB ANSI STANDARD.
- ♦ **PREMIUM GRADE FRP ALSO AVAILABLE**
FOR MORE SEVERE SERVICE CONDITIONS, TITAN FCI CAN PROVIDE A PREMIUM GRADE FRP STRAINER CONSTRUCTED FROM EITHER EPOXY VINYL ESTER OR CHLORENDIC POLYESTER. THIS GRADE OF FRP PROVIDES SUPERB CORROSIVE, ABRASIVE AND HEAT RESISTANCE AND IS APPROPRIATE FOR SERVICE CONDITIONS UP TO 150 PSI WOG. IT IS A LOGICAL ALTERNATIVE TO RUBBER LINED STRAINERS AS WELL AS STRAINERS CONSTRUCTED FROM HIGH COST, EXOTIC ALLOYS SUCH AS ALLOY 20, HASTELLOY-C, MONEL, AND ALUMINUM BRONZE.
- ♦ **AVAILABLE AS A REDUCING STRAINER**
THE OUTLET SIZE CAN BE SIZED SMALLER (CONCENTRICALLY OR ECCENTRICALLY) THAN THE INLET SIZE TO ALLOW FOR LINE SIZE REDUCTION. ADDITIONALLY, LARGER STRAINER BODIES CAN BE FITTED WITH BOTH SMALLER INLET AND OUTLET SIZES IF A LARGER BASKET AREA IS DESIRED FOR EXTRA CAPACITY.
- ♦ **UNIQUE FEATURES**
QUICK-OPENING COVER, HIGH STRENGTH-TO-WEIGHT RATIO, LOW INSTALLATION COST, FIELD REPAIRABLE AND SEE-THROUGH ACRYLIC COVER. ON LARGER STRAINERS, THE COVER CAN BE CONSTRUCTED FROM FRP WITH AN CLEAR ACRYLIC 8" DIAMETER VIEWPORT.
- ♦ **LOWER LOSSES - INCREASED TIME BETWEEN CLEANING**
THE FRP SERIES STRAINERS ARE BUILT WITH A LARGE OUTLET AREA IN THE BASKET CHAMBER. THIS RESULTS IN VERY LOW PRESSURE LOSSES INITIALLY AND MUCH GREATER DEBRIS LOADING BEFORE THE PRESSURE DROP ACROSS THE STRAINER RISES TO THE POINT WHERE CLEANING IS REQUIRED.

TECHNICAL

MAX WORKING PRESSURE
(NON-SHOCK)

ISOPHTHALIC POLYESTER
CONSTRUCTION

50 PSI @ 80 °F

EPOXY VINYL ESTER OR CHLORENDIC
POLYESTER CONSTRUCTION

150 PSI @ 150 °F

APPLICATIONS

MARKETS: CHEMICAL PROCESSING, WATER TREATMENT, FOOD PROCESSING, PULP AND PAPER MILLS, STEEL PROCESSING, PHARMACEUTICAL INDUSTRY, AND POWER PLANTS.

SERVICE: ACID PLANTS, PICKLING, PLATING, CHEMICAL STRAINING (ACIDS AND BASES), HIGH PURITY PROCESSES, AND SEA/BRACKISH WATER.

The above data represents common market and service applications. No representation or guarantee, expressed or implied, is given due to the numerous variations of concentrations, temperatures and flow conditions that may occur during actual service.

TITAN FLOW CONTROL, INC.
YOUR PIPELINE TO THE FUTURE!

Tel: 910-735-0000 ♦ Fax: 910-738-3848 ♦ titan@titanfci.com ♦ www.titanfci.com
290 Corporate Drive ♦ PO Box 7408 ♦ Lumberton, NC 28358



TITAN FLOW CONTROL, Inc.

290 Corporate Drive
Lumberton, NC 28358
Tel: 910.735.0000

E-mail: titan@titanfci.com
Web: www.titanfci.com
Fax: 910.738.3848

SIMPLEX BASKET STRAINER

BS 55-FRP (FIBERGLASS)

Fiberglass Reinforced Plastic • Flat Face

ANSI Class
150

BILL OF MATERIALS (1)

No.	PART	BS 55-FRP
1	Body	Fiberglass Reinforced Plastic
2	Cover	Acrylic or Fiberglass Reinforced Plastic
3	Basket (2)	Stainless Steel Type 304
4	Hand Knobs	Fiberglass Reinforced Plastic with Stainless Steel Insert
5	Eye Bolts	Stainless Steel
6	O-Rings (2)	Ethylene Propylene

1. Bill of Materials represents standard materials. Equivalent or better materials may be substituted at the manufacturer's discretion.
2. Denotes recommended spare parts.

Additional Design and Technical Notes:

- Titan FCI also offers fiberglass larger-sized simplex strainers and duplex strainers. Please contact factory for more information.

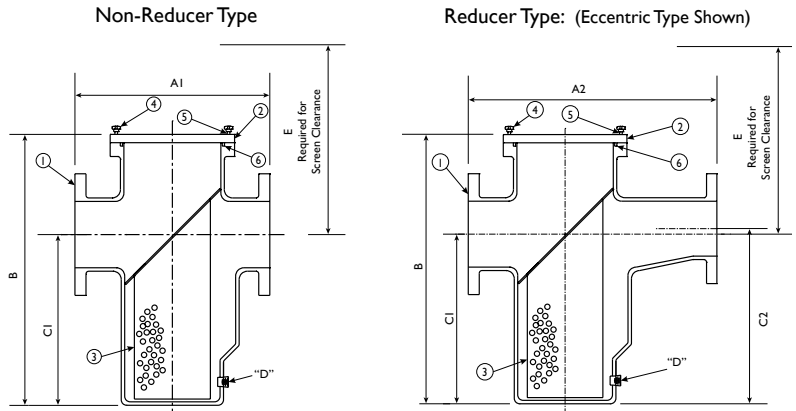

Illustrations are for representational purposes only. Please contact factory for certified drawings when required.
Quick-opening knob cover is rated at 50 PSI. Bolted cover is rated at 150 PSI.

DIMENSIONS AND WEIGHT DATA (1)

Inlet	Outlet	A1 (2) (Face-to-Face) Non-Reducing & Std. Reducing Units Only		A2 (2) (Face-to-Face) Concentric & Eccentric Reducing Units Only		B (Overall Height) All Units		C1 (Centerline-to-Bottom) All Units		C2 (Centerline-to-Bottom) Eccentric Reducing Only		D (Drain Plug)		E (Screen Clearance)		Weight (Approximate)	
		in	mm	in	mm	in	mm	in	mm	in	mm	in	mm	in	mm	lb	kg
4	4	16.625	422	---	---	21.5	546	12.0	304	---	---	3/4	20	31	787	40	18.1
4	3	16.625	422	20.625	523	21.5	546	12.0	304	12.5	317	3/4	20	31	787	40	18.1
4	2.5	16.625	422	20.625	523	21.5	546	12.0	304	13.75	349	3/4	20	31	787	40	18.1
4	2	16.625	422	20.625	523	21.5	546	12.0	304	13.0	330	3/4	20	31	787	40	18.1
6	6	17.625	447	---	---	25.25	641	15.5	393	---	---	1 1/4	32	35	889	52	23.6
6	5	17.625	447	22.625	574	25.25	641	15.5	393	16.0	406	1 1/4	32	35	889	52	23.6
6	4	17.625	447	22.625	574	25.25	641	15.5	393	16.5	419	1 1/4	32	35	889	52	23.6
6	3	---	---	22.625	574	25.25	641	15.5	393	17.0	431	1 1/4	32	35	889	52	23.6
6	2.5	---	---	22.625	574	25.25	641	15.5	393	17.5	444	1 1/4	32	35	889	52	23.6
8	8	23.5	596	---	---	30.25	768	17.5	444	---	---	1 1/2	40	45	1143	85	38.0
8	6	23.5	596	31.0	787	30.25	768	17.5	444	18.5	469	1 1/2	40	45	1143	85	38.0
8	5	23.5	596	31.0	787	30.25	768	17.5	444	19.0	482	1 1/2	40	45	1143	85	38.0
8	4	---	---	31.0	787	30.25	768	17.5	444	19.5	495	1 1/2	40	45	1143	85	38.0
8	3	---	---	31.0	787	30.25	768	17.5	444	20.0	508	1 1/2	40	45	1143	85	38.0
10	10	28.75	730	---	---	34.75	882	21.5	546	---	---	1 1/2	40	48	1219	112	50.0
10	8	28.75	730	38.75	984	34.75	882	21.5	546	22.5	571	1 1/2	40	48	1219	112	50.0
10	6	---	---	38.75	984	34.75	882	21.5	546	23.5	596	1 1/2	40	48	1219	112	50.0
10	5	---	---	38.75	984	34.75	882	21.5	546	24.0	609	1 1/2	40	48	1219	112	50.0
10	4	---	---	38.75	984	34.75	882	21.5	546	24.5	622	1 1/2	40	48	1219	112	50.0
12	12	31.5	800	---	---	37.5	952	23.0	584	---	---	2	50	52	1320	127	57.0
12	10	31.5	800	41.5	1054	37.5	952	23.0	584	24.0	609	2	50	52	1320	127	57.0
12	8	---	---	41.5	1054	37.5	952	23.0	584	25.0	635	2	50	52	1320	127	57.0
12	6	---	---	41.5	1054	37.5	952	23.0	584	26.0	660	2	50	52	1320	127	57.0
12	5	---	---	41.5	1054	37.5	952	23.0	584	26.5	673	2	50	52	1320	127	57.0
14	14	42.0	1066	---	---	48.0	1219	31.0	787	---	---	C/F	C/F	65	1651	340	154.0
14	12	42.0	1066	52.0	1320	48.0	1219	31.0	787	32.0	812	C/F	C/F	65	1651	340	154.0
14	10	---	---	52.0	1320	48.0	1219	31.0	787	33.0	838	C/F	C/F	65	1651	340	154.0
14	8	---	---	52.0	1320	48.0	1219	31.0	787	34.0	863	C/F	C/F	65	1651	340	154.0
14	6	---	---	52.0	1320	48.0	1219	31.0	787	35.0	889	C/F	C/F	65	1651	340	154.0
16	16	42.0	1066	---	---	48.0	1219	31.0	787	---	---	C/F	C/F	65	1651	360	163.0
16	14	42.0	1066	52.0	1320	48.0	1219	31.0	787	32.0	812	C/F	C/F	65	1651	360	163.0
16	12	---	---	52.0	1320	48.0	1219	31.0	787	33.0	838	C/F	C/F	65	1651	360	163.0
16	10	---	---	52.0	1320	48.0	1219	31.0	787	34.0	863	C/F	C/F	65	1651	360	163.0
16	8	---	---	52.0	1320	48.0	1219	31.0	787	35.0	889	C/F	C/F	65	1651	360	163.0
18	18	42.0	1066	---	---	48.0	1219	31.0	787	---	---	C/F	C/F	65	1651	380	172.0
18	16	42.0	1066	52.0	1320	48.0	1219	31.0	787	32.0	812	C/F	C/F	65	1651	380	172.0
18	14	---	---	52.0	1320	48.0	1219	31.0	787	33.0	838	C/F	C/F	65	1651	380	172.0
18	12	---	---	52.0	1320	48.0	1219	31.0	787	34.0	863	C/F	C/F	65	1651	380	172.0
18	10	---	---	52.0	1320	48.0	1219	31.0	787	35.0	889	C/F	C/F	65	1651	380	172.0
20	20	42.0	1066	---	---	48.0	1219	32.5	825	---	---	C/F	C/F	68	1727	380	172.0
20	18	42.0	1066	52.0	1320	48.0	1219	32.5	825	33.5	850	C/F	C/F	68	1727	380	172.0
20	16	---	---	52.0	1320	48.0	1219	32.5	825	34.5	876	C/F	C/F	68	1727	380	172.0
20	14	---	---	52.0	1320	48.0	1219	32.5	825	35.5	901	C/F	C/F	68	1727	380	172.0
20	12	---	---	52.0	1320	48.0	1219	32.5	825	36.5	927	C/F	C/F	68	1727	380	172.0

1. Dimensions and weights are for reference only. When required, request certified drawings.
2. Face to face values have a tolerance of ±0.06 in (±2.0 mm) for sizes 10" and lower and a tolerance of ±0.12 in (±3.0 mm) for sizes 12" and larger.

Titan FCI makes every effort to ensure the information presented on our literature accurately reflects exact product specifications. However, as product changes occur, there may be short-term differences between actual product specifications and the information contained within our literature. Titan FCI reserves the right to make design and specification changes to improve our products without prior notification. When required, request certified drawings.



TITAN FLOW CONTROL, INC.

DUPLEX STRAINER ♦ DUAL BALL TYPE ♦ THREE PIECE BODY
ANSI CLASS 125 ♦ CAST IRON ♦ FLANGED & THREADED ENDS

NEW
Three-Piece
Design!

MODELS: DS 595-CI
 (THREADED - CAST IRON)

DS 695-CI
 (FLANGED - CAST IRON)



1 1/2" DS 695-CI

FEATURES

SIZE RANGE: 3/4" ~ 4"

- ♦ **DUAL-BALL DIVERTER DESIGN**
 THIS DUPLEX IS DESIGNED WITH TWO STAINLESS STEEL BALLS THAT EFFICIENTLY DIVERT THE PIPELINE FLOW FROM ONE BASKET CHAMBER TO THE OTHER. TEFLON SEATS ENSURE A POSITIVE SEAL AND HELP TO PREVENT SEEPAGE INTO THE CHAMBER THAT IS BEING SERVICED FOR CLEANING.
- ♦ **EASY TO OPERATE**
 TITAN FCI'S DUPLEX STRAINER FEATURES A LOW TORQUE, EASY TO OPERATE HANDLE THAT DOES NOT REQUIRE A GEARBOX. ADDITIONALLY, THE HANDLE'S POSITION CLEARLY INDICATES WHICH BASKET IS IN SERVICE AND WHICH BASKET CAN SAFELY BE REMOVED FOR CLEANING.
- ♦ **REDUCED "IN-LINE" MAINTENANCE**
 TITAN'S DUPLEX HAS NUMEROUS ATTRIBUTES THAT HELP REDUCE MAINTENANCE DURING CLEANING OPERATIONS. FIRST, THE DUAL BALL DESIGN ISOLATES EACH CHAMBER AND KEEPS THE SERVICING CHAMBER DRY DURING CLEANING. THERE ARE ALSO NO SPECIAL TOOLS REQUIRED TO ACCESS AND REMOVE THE STRAINING ELEMENT FROM THE CHAMBER. LASTLY, THE DUPLEX PROVIDES COVER VENTS, DRAIN PLUGS, AND FOOT PADS ON EACH CHAMBER.
- ♦ **ENDLESS SCREEN OPTIONS**
 THIS STRAINER CAN BE FITTED WITH VIRTUALLY ANY CONFIGURATION OF PERFORATION OR MESH LINED STRAINING ELEMENTS. STRAINING ELEMENTS CAN ALSO BE CONSTRUCTED FROM SPECIAL MATERIALS SUCH AS ALLOY 20.

TECHNICAL

PRESSURE/TEMPERATURE RATING ⁽¹⁾
 CAST IRON - A126 GR. B - CLASS 125

DS 595-CI (Threaded)
 WOG (Non-shock): 200 PSI @ 150 °F

DS 695-CI (Flanged)
 WOG (Non-shock): 200 PSI @ 150 °F

1. The above listed temperatures are theoretical and may vary during actual operating conditions.

APPLICATIONS

GENERAL APPLICATION: THE DUPLEX STRAINER IS A UNIQUE PRODUCT WITHIN THE PIPELINE INDUSTRY. LIKE OTHER BASKET STRAINERS, THE DUPLEX STRAINER PROTECTS EXPENSIVE DOWNSTREAM EQUIPMENT BY MECHANICALLY REMOVING SOLIDS FROM FLOWING FLUIDS VIA A PERFORATED, MESH, OR WEDGE WIRE STRAINING ELEMENT. HOWEVER, THE DUPLEX STRAINER IS DESIGNED WITH TWO BASKET CHAMBERS AND A FLOW DIVERTER SYSTEM THAT ALLOWS THE PIPELINE FLOW TO BE SWITCHED FROM ONE CHAMBER TO THE OTHER, COMPLETELY ISOLATING THE FLOW TO A SINGLE CHAMBER. THIS MAKES THE DUPLEX STRAINER IDEAL FOR NON-INTERRUPTIBLE APPLICATIONS THAT CANNOT BE SHUT DOWN DURING ROUTINE MAINTENANCE AND CLEANING OPERATIONS.

The above data represents common market and service applications. No representation or guarantee, expressed or implied, is given due to the numerous variations of concentrations, temperatures and flow conditions that may occur during actual service.

TITAN FLOW CONTROL, INC.
 YOUR PIPELINE TO THE FUTURE!

Tel: 910-735-0000 ♦ Fax: 910-738-3848 ♦ titan@titanfci.com ♦ www.titanfci.com
 290 Corporate Drive ♦ PO Box 7408 ♦ Lumberton, NC 28358



TITAN FLOW CONTROL, Inc.
 290 Corporate Drive
 Lumberton, NC 28358
 Tel: 910.735.0000
 E-mail: titan@titanfci.com
 Web: www.titanfci.com
 Fax: 910.738.3848

DUPLEX BASKET STRAINER
DS 595-CI (Threaded)
DS 695-CI (Flanged)
 Dual Ball Type • 3-Piece Body • Cast Iron

ANSI
 Class
 125

BILL OF MATERIALS ⁽¹⁾

No.	Part	DS 595/695-CI
1	Main Body / Basket Housing ⁽²⁾	Cast Iron ASTM A126 Gr. B
2	Straining Element ⁽³⁾	Stainless Steel
3	Cover	Cast Iron ASTM A126 Gr. B
4	Ball	Stainless Steel
5	O-Ring Straining Element	Buna-N
6	Seat Seal	Teflon (PTFE)
7	Seals	Buna-N
8	Handle	Carbon Steel Zinc Coated

1. Bill of Materials represents standard materials. Equivalent or better materials may be substituted at the manufacturer's discretion.
2. Carbon Steel, Stainless Steel, and Aluminum Bronze units are also available.
3. Denotes recommended spare parts.

Cut View

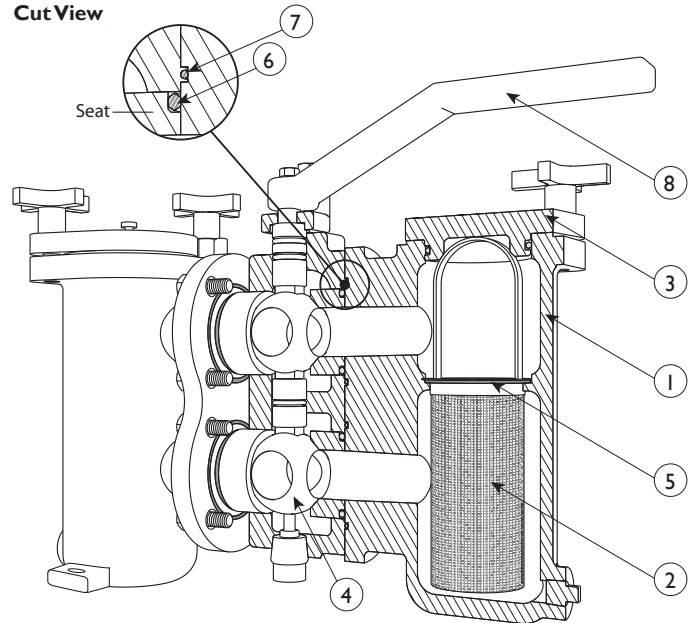

Front View

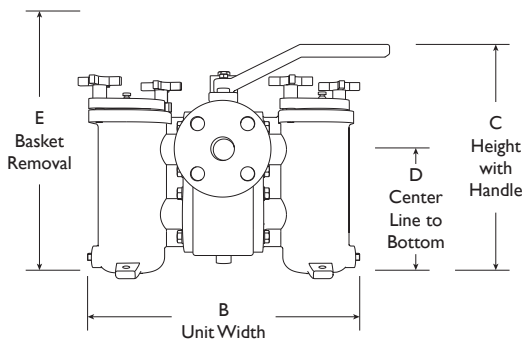

Top View

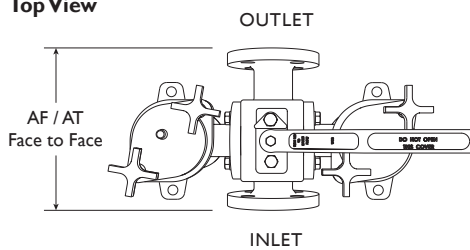

Cut parts shown with hatch.

Illustrations are representative of a 1" DS696-CS (Flanged model). Please ask for certified drawings when required.

DIMENSIONS AND PERFORMANCE DATA ⁽¹⁾

SIZE ⁽²⁾	in	3/4 ⁽³⁾	1	1 1/4	1 1/2	2	2 1/2	3 ⁽³⁾	4 ⁽³⁾
	mm	20	25	32	40	50	65	80	100
AF DIMENSION	in	---	7.0	9.37	9.37	10.6	13.5	13.5	16.0
FLANGED FACE TO FACE	mm	---	178	238	238	270	343	343	406
AT DIMENSION	in	5.59	5.59	7.5	7.5	10.0	11.5	---	---
THREADED FACE TO FACE	mm	142	142	191	191	254	292	---	---
B DIMENSION	in	12.95	12.95	15.12	15.12	18.43	22.05	22.0	26.85
UNIT WIDTH (INCLUDING PLUG)	mm	329	329	384	384	468	560	560	682
C DIMENSION	in	11.0	11.0	14.2	14.2	17.7	22.0	22.0	25.2
HEIGHT WITH HANDLE	mm	280	280	360	360	450	560	560	640
D DIMENSION	in	5.83	5.83	8.3	8.3	10.7	13.7	13.7	15.9
CENTER LINE TO BOTTOM	mm	148	148	211	211	271	347	347	403
E DIMENSION	in	15.4	15.4	21.3	21.3	26.4	35.0	35.0	41.0
BASKET REMOVAL	mm	390	390	541	541	670	885	885	1040
APPROXIMATE WEIGHT	lb	---	46.3	73.9	73.9	121.3	237.0	238.1	373.7
DS 695, FLANGED	kg	---	21	33.5	33.5	55	107.5	108	169.5
APPROXIMATE WEIGHT	lb	43.7	43.0	69.9	69.5	119.0	227.0	---	---
DS 595, THREADED	kg	19.8	19.5	31.7	31.5	54	103	---	---
Flow Coefficient	C _v	13	14	19	24	42	68	105	180

1. Dimensions, weights, and flow coefficients are provided for reference only. Always request certified drawings.
2. Larger sizes (5" ~ 8") are available upon request. Please contact factory for pricing and delivery.
3. Flanged units are not available in 3/4" size; Threaded units are not available in 3" or 4" sizes.

PRESSURE - TEMPERATURE RATING

ANSI Class 125	DS 595/695-CI
WOG (Non-shock)	200 PSI @ 150 °F

REFERENCED STANDARDS & CODES

Code	Description
ASME/ANSI B16.1	Cast Iron Pipe Flanges and Flanged Fittings
ASME/ANSI B16.4	Cast Iron Pipe Threaded Fittings

MATERIAL TEMPERATURES

Seat/Seal/Ball	Temp Range
Buna-N (Seal)	-20 ~ 250 °F
Stainless Steel Ball	Max 450 °F

STANDARD SCREEN SELECTIONS

Size	Liquid	Open Area	Steam	Open Area
3/4" ~ 4"	1/16 (.0625)	41%	Not Recommended	

Titan FCI makes every effort to ensure the information presented on our literature accurately reflects exact product specifications. However, as product changes occur, there may be short-term differences between actual product specifications and the information contained within our literature. Titan FCI reserves the right to make design and specification changes to improve our products without prior notification. When required, request certified drawings.



TITAN FLOW CONTROL, INC.

DUPLEX STRAINER ♦ DUAL BALL TYPE ♦ THREE PIECE BODY
ANSI CLASS 150 ♦ CARBON & STAINLESS ♦ FLANGED & THREADED

**NEW
Three-Piece
Design!**

MODELS: DS 596-CS
(Threaded - Carbon Steel)

DS 596-SS
(Threaded - Stainless Steel)

DS 696-CS
(Flanged - Carbon Steel)

DS 696-SS
(Flanged - Stainless Steel)



1 1/2" DS 696-SS

FEATURES

SIZE RANGE: 3/4" ~ 4"

♦ **DUAL-BALL DIVERTER DESIGN**

THIS DUPLEX IS DESIGNED WITH TWO STAINLESS STEEL BALLS THAT EFFICIENTLY DIVERT THE PIPELINE FLOW FROM ONE BASKET CHAMBER TO THE OTHER. TEFLON SEATS ENSURE A POSITIVE SEAL AND HELP TO PREVENT SEEPAGE INTO THE CHAMBER THAT IS BEING SERVICED FOR CLEANING.

♦ **EASY TO OPERATE**

TITAN FCI'S DUPLEX STRAINER FEATURES A LOW TORQUE, EASY TO OPERATE HANDLE THAT DOES NOT REQUIRE A GEARBOX. ADDITIONALLY, THE HANDLE'S POSITION CLEARLY INDICATES WHICH BASKET IS IN SERVICE AND WHICH BASKET CAN SAFELY BE REMOVED FOR CLEANING.

♦ **REDUCED "IN-LINE" MAINTENANCE**

TITAN'S DUPLEX HAS NUMEROUS ATTRIBUTES THAT HELP REDUCE MAINTENANCE DURING CLEANING OPERATIONS. FIRST, THE DUAL BALL DESIGN ISOLATES EACH CHAMBER AND KEEPS THE SERVICING CHAMBER DRY DURING CLEANING. THERE ARE ALSO NO SPECIAL TOOLS REQUIRED TO ACCESS AND REMOVE THE STRAINING ELEMENT FROM THE CHAMBER. LASTLY, THE DUPLEX PROVIDES COVER VENTS, DRAIN PLUGS, AND FOOT PADS ON EACH CHAMBER.

♦ **ENDLESS SCREEN OPTIONS**

THIS STRAINER CAN BE FITTED WITH VIRTUALLY ANY CONFIGURATION OF PERFORATION OR MESH LINED STRAINING ELEMENTS. STRAINING ELEMENTS CAN ALSO BE CONSTRUCTED FROM SPECIAL MATERIALS SUCH AS ALLOY 20.

TECHNICAL

PRESSURE/TEMPERATURE RATING ⁽¹⁾
CARBON STEEL - A216 GR. WCB - CLASS 150

WOG (Non-shock): 200 PSI @ 150 °F

PRESSURE/TEMPERATURE RATING ⁽¹⁾
STAINLESS STEEL - A351 GR. CF8M - CLASS 150

WOG (Non-shock): 200 PSI @ 150 °F

1. The above listed temperatures are theoretical and may vary during actual operating conditions.

APPLICATIONS

GENERAL APPLICATION: THE DUPLEX STRAINER IS A UNIQUE PRODUCT WITHIN THE PIPELINE INDUSTRY. LIKE OTHER BASKET STRAINERS, THE DUPLEX STRAINER PROTECTS EXPENSIVE DOWNSTREAM EQUIPMENT BY MECHANICALLY REMOVING SOLIDS FROM FLOWING FLUIDS VIA A PERFORATED, MESH, OR WEDGE WIRE STRAINING ELEMENT. HOWEVER, THE DUPLEX STRAINER IS DESIGNED WITH TWO BASKET CHAMBERS AND A FLOW DIVERTER SYSTEM THAT ALLOWS THE PIPELINE FLOW TO BE SWITCHED FROM ONE CHAMBER TO THE OTHER, COMPLETELY ISOLATING THE FLOW TO A SINGLE CHAMBER. THIS MAKES THE DUPLEX STRAINER IDEAL FOR NON-INTERRUPTIBLE APPLICATIONS THAT CANNOT BE SHUT DOWN DURING ROUTINE MAINTENANCE AND CLEANING OPERATIONS.

The above data represents common market and service applications. No representation or guarantee, expressed or implied, is given due to the numerous variations of concentrations, temperatures and flow conditions that may occur during actual service.

TITAN FLOW CONTROL, INC.
YOUR PIPELINE TO THE FUTURE!

Tel: 910-735-0000 ♦ Fax: 910-738-3848 ♦ titan@titanfci.com ♦ www.titanfci.com
290 Corporate Drive ♦ PO Box 7408 ♦ Lumberton, NC 28358



TITAN FLOW CONTROL, Inc.

290 Corporate Drive
Lumberton, NC 28358
Tel: 910.735.0000

E-mail: titan@titanfci.com
Web: www.titanfci.com
Fax: 910.738.3848

DUPLEX BASKET STRAINER

Threaded Ends

DS 596-CS (Carbon Steel)
DS 596-SS (Stainless Steel)

Flanged Ends

DS 696-CS (Carbon Steel)
DS 696-SS (Stainless Steel)

ANSI
Class
150

BILL OF MATERIALS ⁽¹⁾

No.	Part	DS 596/696-CS	DS 596/696-SS
1	Main Body / Basket Housing ⁽²⁾	Carbon Steel A216 Gr.WCB	Stainless Steel A351 Gr.CF8M
2	Straining Element ⁽³⁾	Stainless Steel	Stainless Steel
3	Cover	Carbon Steel A216 Gr.WCB	Stainless Steel A351 Gr.CF8M
4	Ball	Stainless Steel	Stainless Steel
5	O-Ring Straining Element	Buna-N	Viton
6	Seat Seal	Teflon (PTFE)	Teflon (PTFE)
7	Seals	Buna-N	Viton
8	Handle	Carbon Steel Zinc Coated	Carbon Steel Zinc Coated

- Bill of Materials represents standard materials. Equivalent or better materials may be substituted at the manufacturer's discretion.
- Aluminum Bronze and Cast Iron units are also available.
- Denotes recommended spare parts.

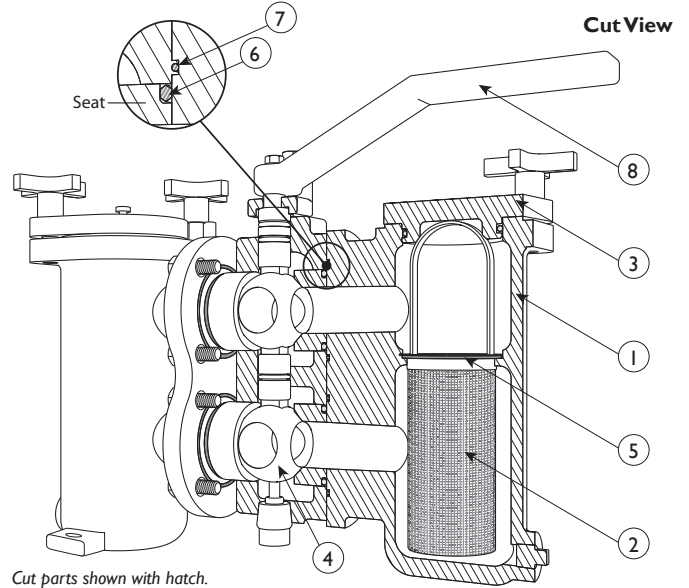

Cut parts shown with hatch.
Illustrations are representative of a 1" DS696-CS (Flanged model).
Please ask for certified drawings when required.

Front View

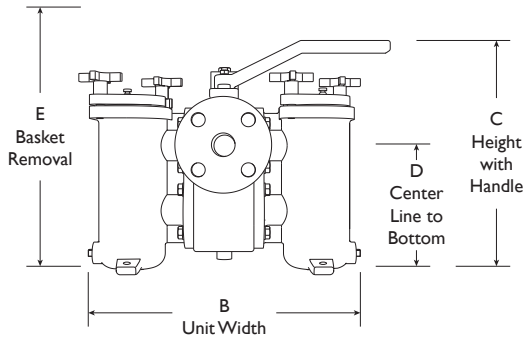

Top View

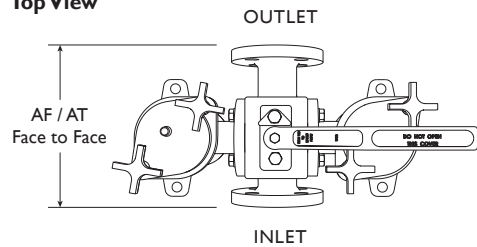

DIMENSIONS AND PERFORMANCE DATA ⁽¹⁾

SIZE ⁽²⁾	in	3/4 ⁽³⁾	1	1 1/4	1 1/2	2	2 1/2	3 ⁽³⁾	4 ⁽³⁾
	mm	20	25	32	40	50	65	80	100
AF DIMENSION FLANGED FACE TO FACE	in	---	7.0	9.37	9.37	10.6	13.5	13.5	16.0
	mm	---	178	238	238	270	343	343	406
AT DIMENSION THREADED FACE TO FACE	in	5.59	5.59	7.5	7.5	10.0	11.5	---	---
	mm	142	142	191	191	254	292	---	---
B DIMENSION UNIT WIDTH (INCLUDING PLUG)	in	12.95	12.95	15.12	15.12	18.43	22.05	22.0	26.85
	mm	329	329	384	384	468	560	560	682
C DIMENSION HEIGHT WITH HANDLE	in	11.0	11.0	14.2	14.2	17.7	22.0	22.0	25.2
	mm	280	280	360	360	450	560	560	640
D DIMENSION CENTER LINE TO BOTTOM	in	5.83	5.83	8.3	8.3	10.7	13.7	13.7	15.9
	mm	148	148	211	211	271	347	347	403
E DIMENSION BASKET REMOVAL	in	15.4	15.4	21.3	21.3	26.4	35.0	35.0	41.0
	mm	390	390	541	541	670	885	885	1040
APPROXIMATE WEIGHT DS 696, FLANGED	lb	---	46.3	73.9	73.9	121.3	237.0	238.1	373.7
	kg	---	21	33.5	33.5	55	107.5	108	169.5
APPROXIMATE WEIGHT DS 596, THREADED	lb	43.7	43.0	69.9	69.5	119.0	227.0	---	---
	kg	19.8	19.5	31.7	31.5	54	103	---	---
Flow Coefficient	C _v	13	14	19	24	42	68	105	180

- Dimensions, weights, and flow coefficients are provided for reference only. Always request certified drawings.
- Larger sizes (5" ~ 8") are available upon request. Please contact factory for pricing and delivery.
- Flanged units are not available in 3/4" size; threaded units are not available in 3" or 4" sizes.

PRESSURE - TEMPERATURE RATING

ANSI Class 150	DS 596/696-CS	DS 596/696-SS
WOG (Non-shock)	200 PSI @ 150 °F	200 PSI @ 150 °F

REFERENCED STANDARDS & CODES

Code	Description
ASME/ANSI B16.5	Pipe Flanges and Flanged Fittings
ASME/ANSI B16.11	Forged Steel Fittings, Socket-Welding, and Threaded

MATERIAL TEMPERATURES

Seat/Seal/Ball	Temp Range
Buna-N (Seal)	-20 ~ 250 °F
Viton (Seal)	-40 ~ 400 °F
Stainless Steel Ball	Max 450 °F

STANDARD SCREEN SELECTIONS

Size	Liquid	Open Area	Steam	Open Area
3/4" ~ 4"	1/16 (.0625)	41%	Not Recommended	

Titan FCS/SS makes every effort to ensure the information presented on our literature accurately reflects exact product specifications. However, as product changes occur, there may be short-term differences between actual product specifications and the information contained within our literature. Titan FCS/SS reserves the right to make design and specification changes to improve our products without prior notification. When required, request certified drawings.



TITAN FLOW CONTROL, INC.

DUPLEX STRAINER ♦ QUAD BALL TYPE ♦ THREE PIECE BODY
ASME CLASS 125 (CI) & 150 (CS & SS) ♦ FLANGED

MODELS: DS 695-CI
 (Flanged - Cast Iron)

DS 696-CS
 (Flanged - Carbon Steel)

DS 696-SS
 (Flanged - Stainless Steel)

NEW
Quad-Ball
Design!

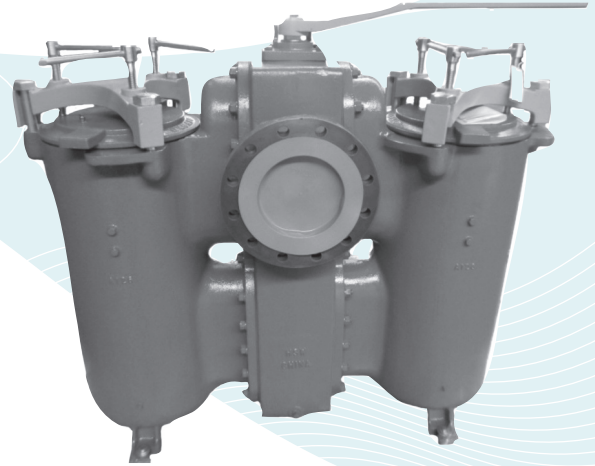

FEATURES

- ♦ **UNIQUE QUAD-BALL DIVERSION SYSTEM**
 REVOLUTIONARY FOUR BALL DESIGN THAT EFFICIENTLY DIVERTS THE PIPELINE FLOW FROM ONE CHAMBER TO THE OTHER. TEFLON SEATS ENSURE A POSITIVE SEAL AND HELP TO PREVENT SEEPAGE INTO THE CHAMBER THAT IS BEING CLEANED.
- ♦ **LOW OPERATING TORQUE**
 TITAN FCI'S DUPLEX STRAINER FEATURES A LOW TORQUE, EASY TO OPERATE HANDLE THAT DOES NOT REQUIRE ANY AUTOMATION. ADDITIONALLY, THE HANDLE'S POSITION CLEARLY INDICATES WHICH BASKET IS IN SERVICE AND WHICH BASKET CAN SAFELY BE REMOVED FOR CLEANING.
- ♦ **REDUCED MAINTENANCE**
 THE QUAD BALL DESIGN ISOLATES EACH CHAMBER AND KEEPS THE SERVICING CHAMBER DRY DURING CLEANING. NO SPECIAL TOOLS ARE REQUIRED TO ACCESS AND REMOVE THE STRAINING ELEMENT FROM THE CHAMBER. COVER VENTS, DRAIN PLUGS, AND FOOT PADS ARE PROVIDED ON EACH CHAMBER.
- ♦ **NUMEROUS OTHER BENEFITS**
 TITAN'S NEW DESIGN OFFERS COUNTLESS OTHER ADVANTAGES INCLUDING: NO INTERRUPTION IN SERVICE, COMPACT STRUCTURE, LONG SERVICE LIFE, AND LOW PRESSURE DROP.

SIZE RANGE: 6" ~ 8"

TECHNICAL

PRESSURE/TEMPERATURE RATING ⁽¹⁾
 CAST IRON - A126 GR.B - CLASS 125

WOG (Non-shock): 200 PSI @ 150 °F

PRESSURE/TEMPERATURE RATING ⁽¹⁾
 CARBON STEEL - A216 GR. WCB - CLASS 150

WOG (Non-shock): 285 PSI @ 100 °F

PRESSURE/TEMPERATURE RATING ⁽¹⁾
 STAINLESS STEEL - A351 GR. CF8M - CLASS 150

WOG (Non-shock): 275 PSI @ 100 °F

1. The above listed temperatures are theoretical and may vary during actual operating conditions.

APPLICATIONS

GENERAL APPLICATION: THE DUPLEX STRAINER IS A UNIQUE PRODUCT WITHIN THE PIPELINE INDUSTRY. LIKE OTHER BASKET STRAINERS, THE DUPLEX STRAINER PROTECTS EXPENSIVE DOWNSTREAM EQUIPMENT BY MECHANICALLY REMOVING SOLIDS FROM FLOWING FLUIDS VIA A PERFORATED, MESH, OR WEDGE WIRE STRAINING ELEMENT. HOWEVER, THE DUPLEX STRAINER IS DESIGNED WITH TWO BASKET CHAMBERS AND A FLOW DIVERTER SYSTEM THAT ALLOWS THE PIPELINE FLOW TO BE SWITCHED FROM ONE CHAMBER TO THE OTHER, COMPLETELY ISOLATING THE FLOW TO A SINGLE CHAMBER. THIS MAKES THE DUPLEX STRAINER IDEAL FOR NON-INTERRUPTIBLE APPLICATIONS THAT CANNOT BE SHUT DOWN DURING ROUTINE MAINTENANCE AND CLEANING OPERATIONS.

The above data represents common market and service applications. No representation or guarantee, expressed or implied, is given due to the numerous variations of concentrations, temperatures and flow conditions that may occur during actual service.

TITAN FLOW CONTROL, INC.
YOUR PIPELINE TO THE FUTURE!

Tel: 910-735-0000 ♦ Fax: 910-738-3848 ♦ titan@titanfci.com ♦ www.titanfci.com
 290 Corporate Drive ♦ PO Box 7408 ♦ Lumberton, NC 28358



TITAN FLOW CONTROL, Inc.

290 Corporate Drive
Lumberton, NC 28358
Tel: 910.735.0000

E-mail: titan@titanfci.com
Web: www.titanfci.com
Fax: 910.738.3848

DUPLEX BASKET STRAINER

Flanged Ends

DS 696-CS (Carbon Steel) • **DS 696-SS** (Stainless Steel)
DS 695-CI (Cast Iron)

ASME Class
125 CI

ASME Class
150 CS & SS

BILL OF MATERIALS (1)

No.	Part	DS 696-CS	DS 696-SS	DS 695-CI
1	Body	Carbon Steel A216 Gr.WCB	Stainless Steel A351 Gr. CF8M	Cast Iron A126 Gr. B
2	Straining Element (3)	Stainless Steel	Stainless Steel	Stainless Steel
3	Cover	Carbon Steel A216 Gr.WCB	Stainless Steel A351 Gr. CF8M	Cast Iron A126 Gr. B
4	Ball	Stainless Steel Type 304	Stainless Steel Type 304	Stainless Steel Type 304
5	O-Ring	Buna-N	Viton	Buna-N
6	Seat	Teflon (PTFE)	Teflon (PTFE)	Teflon (PTFE)
7	Seal	Buna-N	Viton	Buna-N
8	O-Ring Body	Buna-N	Viton	Buna-N
9	Handle	Carbon Steel Zinc Coated	Carbon Steel Zinc Coated	Carbon Steel Zinc Coated

1. Bill of Materials represents standard materials. Equivalent or better materials may be substituted at the manufacturer's discretion.
2. Aluminum Bronze units are also available.
3. Denotes recommended spare parts.

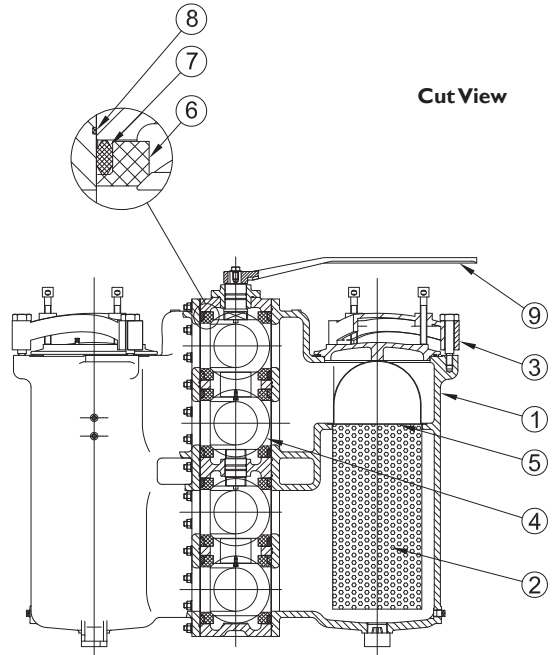

Cut View

DIMENSIONS AND PERFORMANCE DATA (1)

SIZE (2)	in	6"	8"
	mm	300	350
AF DIMENSION FACE TO FACE	in	22	26.75
	mm	559	680
B DIMENSION UNIT WIDTH (INCLUDING PLUG)	in	35.31	48.50
	mm	897	1368
C DIMENSION HEIGHT WITH HANDLE	in	35.63	45.12
	mm	905	1146
D DIMENSION CENTER LINE TO BOTTOM	in	24.45	30.39
	mm	621	772
E DIMENSION BASKET REMOVAL	in	48	62
	mm	1220	1575
APPROXIMATE WEIGHT DS DS695/696, FLANGED	lb	850	1600
	kg	386	726
Flow Coefficient	C _v	429	776

1. Dimensions, weights, and flow coefficients are provided for reference only. Always request certified drawings.

Please contact factory for more information.

Larger, fabricated duplex strainers are available. Fabricated duplex strainers can be designed to meet any space or application requirements.

Front View

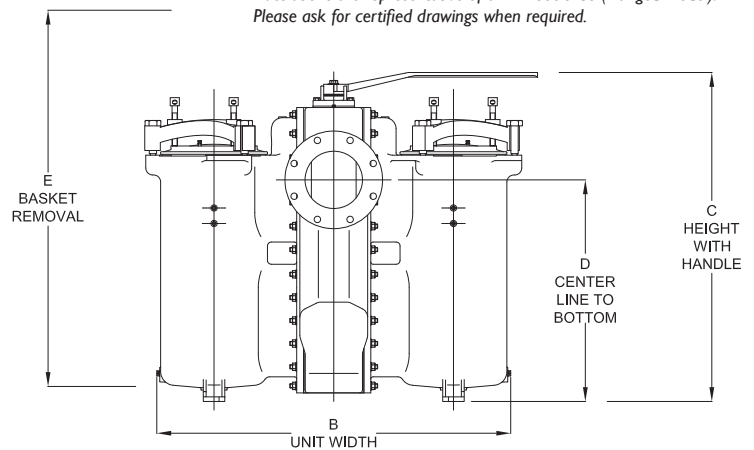

Cut parts shown with hatch.

Illustrations are representative of a 1" DS696-CS (Flanged model). Please ask for certified drawings when required.

Top View

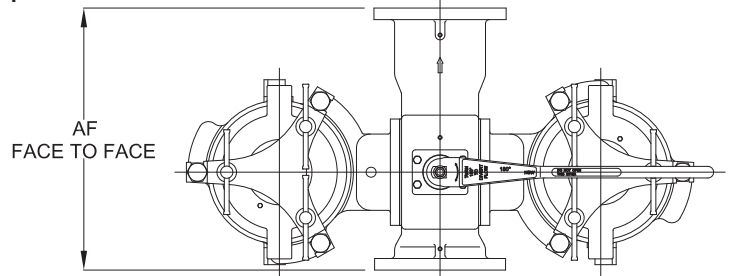

PRESSURE - TEMPERATURE RATING

ASME Class 125	DS 695-CI	
WOG (Non-shock)	200 PSI @ 150 °F	
ASME Class 150	DS 696-CS	DS 696-SS
WOG (Non-shock)	285 PSI @ 100 °F	275 PSI @ 100 °F

MATERIAL TEMPERATURES

Seat/Seal/Ball	Temp Range
Buna-N (Seal)	-20 ~ 250 °F
Viton (Seal)	-40 ~ 400 °F
Stainless Steel Ball	Max 450 °F

STANDARD SCREEN SELECTIONS

Size	Liquid	Open Area	Steam	Open Area
6" ~ 8"	1/8" (0.125)	41%	Not Recommended	

REFERENCED STANDARDS & CODES

Code	Description
ASME/ANSI B16.5	Pipe Flanges and Flanged Fittings
ASME/ANSI B16.11	Forged Steel Fittings, Socket-Welding, and Threaded
ASME B16.1	Gray Iron Pipe Flanges and Flanged Fittings

Titan FCS/SS makes every effort to ensure the information presented on our literature accurately reflects exact product specifications. However, as product changes occur, there may be short-term differences between actual product specifications and the information contained within our literature. Titan FCS/SS reserves the right to make design and specification changes to improve our products without prior notification. When required, request certified drawings.



TITAN FABRICATIONS

MADE IN THE USA | WORLD-CLASS | INNOVATIVE

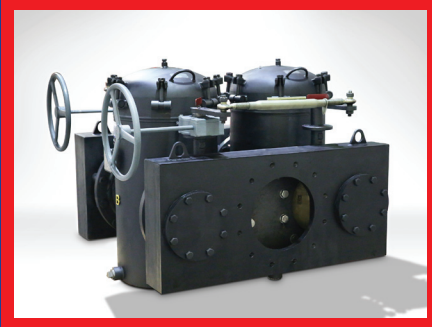
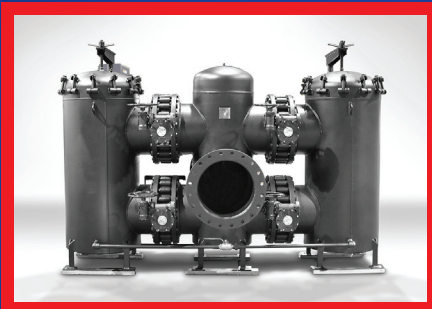

PRODUCT CATALOG

BASKET STRAINERS | DUPLEX STRAINERS | TEE STRAINERS

UNLIMITED CUSTOMER SPECIFIC DESIGN OPTIONS | NUMEROUS MATERIAL OPTIONS

WWW.TITANFCI.COM

290 Corporate Drive | Lumberton, NC 28358 | 910.735.0000

CONTENTS

3. **Brand New Facility**
4. **Options for Fabricated Products**
5. **Basket Strainers**
ANSI Class 150, 300: Sizes 2" - 10"
7. **Basket Strainers**
ANSI Class 150, 300: Sizes 12" - 48"
9. **Basket Strainers**
ANSI Class 600 Sizes: 2" - 12"
11. **Duplex Strainer (Inline)**
ANSI Class 150, 300: Sizes 2" - 24"
13. **Duplex Strainer (Offset)**
ANSI Class 150, 300: Sizes 2" - 24"
15. **Tee Strainers**
ANSI Class 150 Sizes: 2" - 30"
17. **Tee Strainers**
ANSI Class 300 Sizes: 2" - 30"
19. **Tee Strainers**
ANSI Class 600 Sizes: 2" - 30"
21. **Temporary Strainers**
23. **Spectacle Blinds, Closed Blinds,
Opens Blinds**
25. **Restriction Orifice Plates**
27. **Design Capabilities**
28. **Model Identification
Numbering System**

BRAND NEW FACILITY

"Made in the USA" isn't just a marketing slogan for us. We take tremendous pride in knowing that we are part of the industrial movement to bring manufacturing jobs and skills back to the USA. Our fabricated products are proudly made in our world-class facility located in the southeastern part of North Carolina.

STATE-OF-THE-ART FACILITY

Titan Flow Control has invested millions of dollars into our world-class fabrication facility. Our brand new, 40,000 sq. ft. facility contains state-of-the-art fabrication equipment including: **Waterjet Technology, Robotic Pipe Cutters, CNC Machines, and one-of-a-kind machines designed explicitly by Titan's engineers.**



Building The Future Of Fabrication

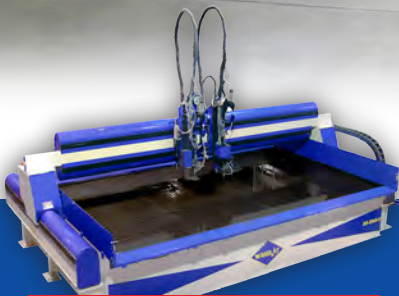

▶ Emerging Tech

Waterjet cutting is ideal when precise part cutting is required. Our water jet has a large cutting area of 96" x 156" and can cut materials up to 12" thick with tolerances up to .005" can be achieved. We can cut steels, laminates, composites, plastics, rubber, gaskets, fiberglass, and much more.



▶ Robotic Cutting

Titan's robotic pipe cutter can automatically cut pipe with diameters ranging from 3" all the way up to 48". This 5-Axis, Robotic Pipe Cutter is capable of making numerous types of intricate cuts including: saddles, multiple saddles, miter, double miter, gusset slots, offshore crowns, and much more.



▶ CNC Machining

Titan has a variety of CNC vertical mills, horizontal mills and turning centers. These machines are capable of running 24 hours a day, 365 days a year. Speed, accuracy, economy, and repeatable are only a few advantages of our machines when comparable to traditional, manual machines.

We love to show off, so call us for a tour today! ▶ ▶ ▶  910.735.0000

OPTIONS FOR FABRICATED PRODUCTS

COVER OPTIONS - FABRICATED STRAINERS

Titan Flow Control, Inc. cover options are designed for various strainers types and sizes so that the straining element is accessible for cleaning and maintenance, an important concern especially with large strainers. To make sure that you choose the best cover for your application, ask a Titan Sales Representative or Engineer.

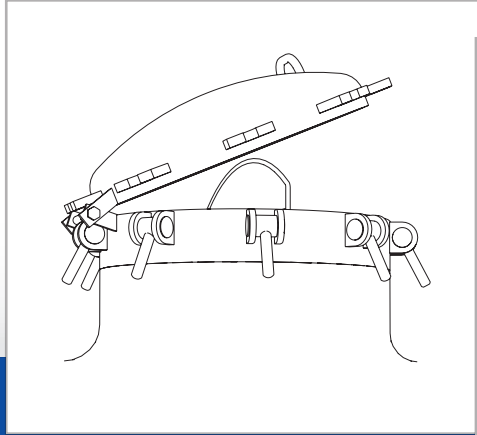

Hinged Cover (T-Bolt)

A **Hinged Cover** is a quick opening cover that is secured with bolts around the outside of the cover. Rotating on its hinge, this cover is easiest to maneuver when it is on a small strainer, in a vertical position, or on the bottom of the strainer.

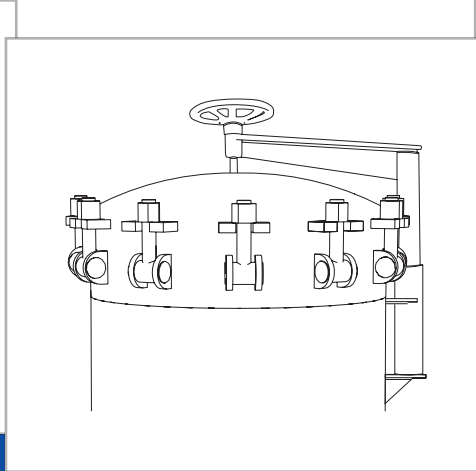

Davit Cover Assembly

Davit Cover Assemblies mechanically aid in removing and replacing covers that would normally be too large for one operator to adjust unaccompanied. Lift davits also ensure that the cover is properly positioned and aligned with strainer.

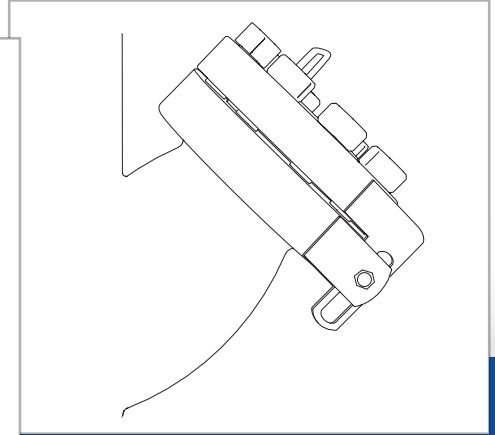

Bolted Slide Hinge Cover

With a **Bolted Slide Hinge Cover**, the cover slides slightly away from the strainer so it has clearance to rotate. Although these covers in small sizes may be removed by a single operator, a lifting eye is available to aid in removal of larger covers.

FLOW OPTIONS - FABRICATED STRAINERS

Titan Flow Control, Inc. offers various options for the placement of inlet and outlet nozzles in order to accommodate each unique piping system. Please contact the factory with your needs, questions, and concerns.

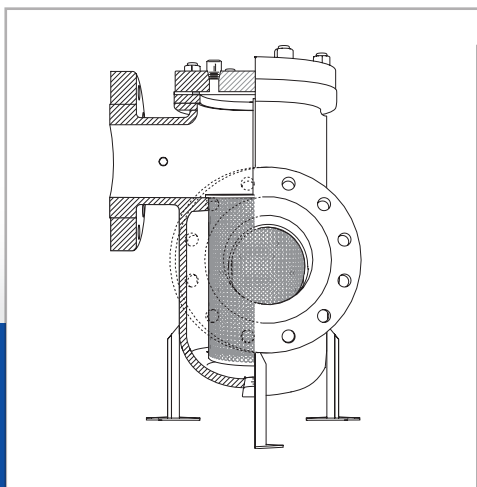

Right Angle Flow

Right Angle Flow fabricated strainers can be placed in a pipeline where it has a 90 degree corner, eliminating the need for a pipeline elbow.

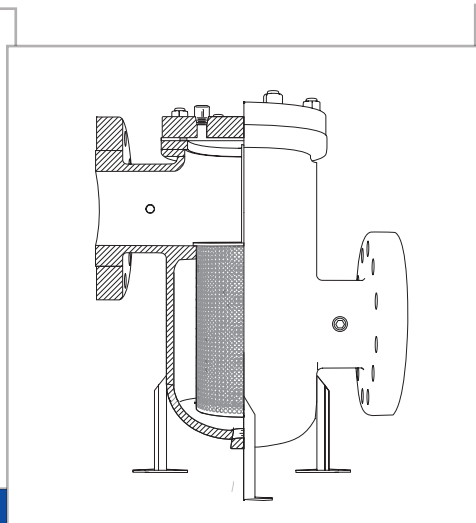

Offset Flow

Offset Flow fabricated strainers can align with pipes at different levels.

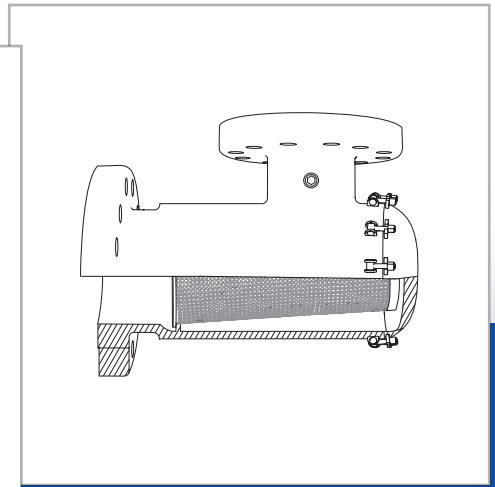

Horizontal-Vertical Flow

Horizontal-Vertical Flow fabricated strainers accommodate piping systems in which the flow changes from horizontal to vertical.

Contact Titan Flow Control, Inc. to learn about additional capabilities and information related to Titan's Fabricated Designs. This brochure is general in nature and is not a substitute for discussing your specific piping requirements with a Titan Sales Representative and obtaining certified engineering documents.

FABRICATED BASKET STRAINERS

2" - 10" | ANSI CLASS 150, 300

LARGER SIZES AVAILABLE

Fabricated Basket strainers are required when an off-the-shelf solution will not meet your exact piping requirements. All of our Fabricated Strainers are made right here in the USA, at our state-of-the-art facility in the southeastern part of North Carolina.

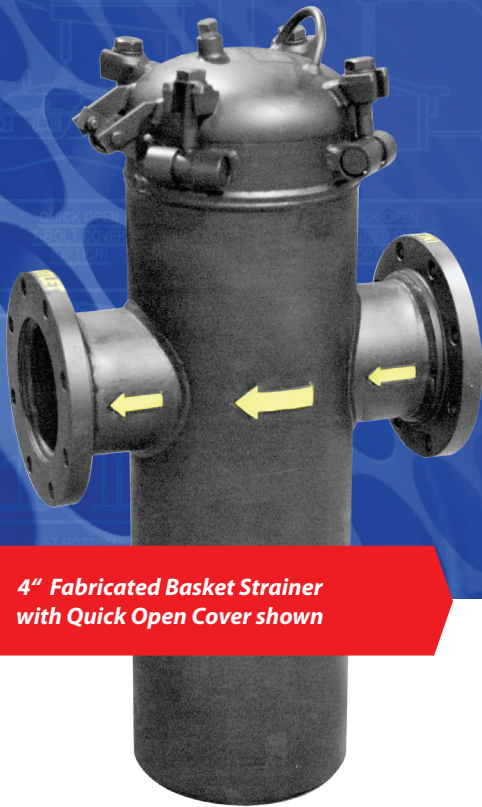

4" Fabricated Basket Strainer with Quick Open Cover shown

Sizes 2" - 48" Available

CUSTOM COVER SOLUTIONS INCLUDING DAVITS & HINGED COVER



HINGED

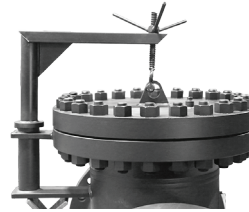

DAVIT



BOLTED

MODELS

FB 20 Series - 150 Class

FB 30 Series - 300 Class

MATERIALS:

- Carbon Steel • Stainless Steel
- Other Alloys

OPTIONS



- Gauge Taps
- Vent/drains - (Standard)
- Back Flush Valves
- Semi-Automatic
- Pressure Gauges
- DP Gauge Switch
- Support Legs



ANSI CLASSES

ANSI Class 150 up to high pressure 900 class



STRAINING ELEMENTS

Customize to fit your requirements
Heavy Duty Baskets, Wedge Wire, & Multi Basket Designs



END CONNECTIONS

Flanged, Raised Face, RTJ, Butt Weld, Socket Weld, Threaded



SANITARY

Sanitary Application Designs for food/pharmaceutical processing



TEMPERATURE CONTROL

Steam Jacket casing for set temperature control



UNIQUE PROJECTS

Rotated and Offset Nozzles to fit into your applications



290 Corporate Dr
www.titanfci.com
Phone: 910.735.0000

Lumberton, NC 28358
titan@titanfci.com
Fax: 910.738.3848

2" - 10"

**FB 20 & FB 30 Series
Basket Strainer
(Single Basket)**

ANSI Class
150, 300

BILL OF MATERIALS ⁽¹⁾
FB 20 & FB 30 Series (Single Basket)

Part	FB 20 & FB 30 Carbon Steel	FB 20 & FB 30 Stainless Steel
1 Body	Carbon Steel A106 Gr.B	Stainless Steel SA312 Type 316
2 Body Flange	Carbon Steel A105	Stainless Steel SA182 Type 316
3 Cover	Bolted: Carbon Steel A105 Quick-Open: Carbon Steel A516 Gr. 70	Bolted: Stainless Steel SA182 Type 316 Quick-Open: Stainless Steel Type 316
4 Pipe Cap	Carbon Steel A234 Gr.WPB	Stainless Steel SA403 Type 316
5 Inlet/Outlet Flange	Carbon Steel A105	Stainless Steel SA182 Type 316
6 Nozzle Inlet/Outlet	Carbon Steel A106 Gr.B	Stainless Steel SA312 Type 316
7 Lifting Lug ⁽⁴⁾	Carbon Steel	Stainless Steel
8 Gasket/O-Ring ⁽²⁾	Bolted Cover: Spiral Wound Stainless Steel Quick-Open: Buna-N ⁽³⁾	
9 Basket Support	Carbon Steel A36 or A516-70	Stainless Steel A240 316
10 Straining Element ⁽²⁾	T304 SS	T304 SS
11 Drain	Carbon Steel A105	Stainless Steel SA182 Type 316
12 Vent with Plug ⁽⁵⁾	Carbon Steel A105	Stainless Steel SA182 Type 316
13 Studs	Carbon Steel A193 B7	Stainless Steel A193 B8 M
14 Nuts	Carbon Steel A194 2H	Stainless Steel A194 Gr.8
15 T-Bolt	Carbon Steel A325	Stainless Steel
16 T-Bolt Closure	Carbon Steel	Stainless Steel Type 316

1. Bill of Materials represents standard materials. Equivalent or better materials may be substituted at the manufacturer's discretion.
2. Titan recommends keeping spare parts on hand.
3. Buna-N is standard for applications below 250° F. Viton is standard for applications above 250° F.
4. Lifting lug not shown.
5. 1/2" NPT is standard.

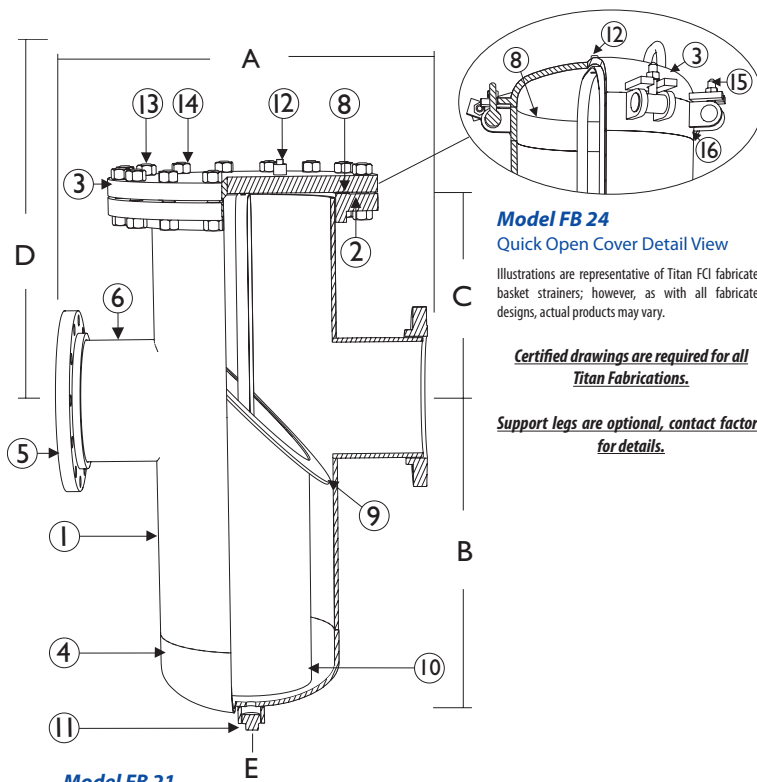

Model FB 24
Quick Open Cover Detail View

Illustrations are representative of Titan FCI fabricated basket strainers; however, as with all fabricated designs, actual products may vary.

Certified drawings are required for all Titan Fabrications.

Support legs are optional, contact factory for details.

Model FB 21
Bolted Cover View

FB 20 & FB 30 Series Basket Strainer Dimensions: 2" - 10"⁽⁴⁾ | ANSI CLASS 150, 300

DIMENSIONS AND WEIGHTS ⁽¹⁾

	in	2	2 1/2	3	4	5	6	8	10
	mm	50	65	80	100	125	150	200	250
A - Face to Face ⁽²⁾⁽⁶⁾ FB 21, FB 24, FB 31, FB 34	in	18.00	C/F	20.00	24.00	C/F	28.00	30.00	32.00
	mm	457	C/F	508	610	C/F	711	762	813
B - Center to Bottom ⁽⁵⁾	in	10.00	C/F	12.00	16.00	C/F	21.00	30.00	36.00
	mm	254	C/F	305	406	C/F	533	762	914
C - Center to Top ⁽³⁾	in	8.00	C/F	10.00	11.00	C/F	12.00	14.00	18.00
	mm	203	C/F	254	279	C/F	305	356	457
D - Screen Removal	in	24.00	C/F	30.00	35.00	C/F	41.00	53.00	66.00
	mm	610	C/F	762	889	C/F	1041	1346	1676
E - NPT	in	.75	C/F	.75	1.00	C/F	1.00	1.50	1.50
	mm	19	C/F	19	25	C/F	25	38	38
Approx. Weight: FB 21 Bolted (ANSI 150)	lb	115.00	C/F	125.00	220.00	C/F	350.00	520.00	700.00
	kg	52	C/F	57	100	C/F	159	236	318
Approx. Weight: FB 24 Quick Open (ANSI 150)	lb	100.00	C/F	110.00	190.00	C/F	300.00	450.00	580.00
	kg	45	C/F	50	86	C/F	136	204	263
Approx. Weight: FB 31 Bolted (ANSI 300)	lb	200.00	C/F	210.00	325.00	C/F	550	830.00	1325.00
	kg	91	C/F	95	147	C/F	250	377	601
Approx. Weight: FB 34 Quick Open (ANSI 300)	lb	158.00	C/F	178.00	255.00	C/F	425.00	655.00	1025.00
	kg	71	C/F	81	116	C/F	193	297	465

1. Dimensions and weights of the FB 21, FB 24, FB 31, FB 34 are provided for reference only. Certified drawings are required for all Titan Fabrications.
2. Face to face values have a tolerance of ±0.06 in (±0.06 mm) for sizes 10" and lower and a tolerance of ±0.12 in (±0.12 mm) for sizes 12" and larger.
3. Centerline dimension is from the top of body flange. Does not include cover. Quick open cover dimension is to the top of body housing.

4. Larger sizes are available. Please consult page 7 of catalog.
5. Centerline to bottom dimension is to bottom of body housing and does not include the NPT plug.
6. Face to face dimension listed are for flanged units only. Please call factory for more information.

Titan FCI's fabricated products are made to each customer's unique specifications. Dimensions, materials, and all other product details referenced in this literature are general in nature. Some options may not be available in all sizes and/or models. Titan FCI reserves the right to make design and specification changes to improve the products without prior notification. For exact product specifications, please consult the Titan FCI factory and request certified engineering documents.

FABRICATED BASKET STRAINERS

12" - 48" | ANSI CLASS 150, 300

SMALLER SIZES AVAILABLE

Fabricated Basket strainers are required when an off-the-shelf solution will not meet your exact piping requirements. All of our Fabricated Strainers are made right here in the USA, at our state-of-the-art facility in the southeastern part of North Carolina.

16" Fabricated Basket Strainer with Optional Davit Assembly shown



Sizes 2" - 48" Available

CUSTOM COVER SOLUTIONS INCLUDING DAVITS & HINGED COVER



HINGED

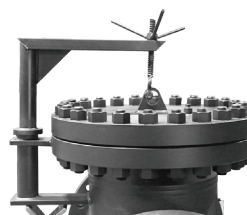

DAVIT



BOLTED

MODELS

FB 20 Series - 150 Class

FB 30 Series - 300 Class

MATERIALS:

- Carbon Steel • Stainless Steel
- Other Alloys

OPTIONS



- Gauge Taps
- Vent/drains - (Standard)
- Back Flush Valves
- Semi-Automatic
- Pressure Gauges
- DP Gauge Switch
- Support Legs

ANSI CLASSES

ANSI Class 150
up to high pressure
900 class



END CONNECTIONS

Flanged, Raised Face,
RTJ, Butt Weld, Socket
Weld, Threaded



STRAINING ELEMENTS

Customize to fit your
requirements

Heavy Duty Baskets,
Wedge Wire, & Multi
Basket Designs



SANITARY

Sanitary Application
Designs for
food/pharmaceutical
processing

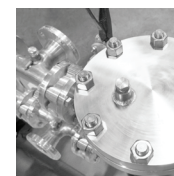

TEMPERATURE CONTROL

Steam Jacket casing
for set temperature
control



UNIQUE PROJECTS

Rotated and Offset
Nozzles to fit into
your applications





290 Corporate Dr
www.titanfci.com
Phone: 910.735.0000

Lumberton, NC 28358
titan@titanfci.com
Fax: 910.738.3848

12" - 48"

FB 20 & 30 Series
Basket Strainer
(Multi Basket)

ANSI Class
150, 300

BILL OF MATERIALS⁽¹⁾
FB 20 & FB 30 Series (Multi-Basket)

Part	FB 20 & FB 30 Carbon Steel	FB 20 & FB 30 Stainless Steel
1 Body	Carbon Steel A106 Gr.B	Stainless Steel SA312 Type 316
2 Body Flange	Carbon Steel A105	Stainless Steel SA182 Type 316
3 Cover	Bolted: Carbon Steel A105 Quick-Open: Carbon Steel A516 Gr. 70	Bolted: Stainless Steel SA182 Type 316 Quick-Open: Stainless Steel Type 316
4 Pipe Cap	Carbon Steel A234 Gr.WPB	Stainless Steel SA403 Type 316
5 Inlet/Outlet Flange	Carbon Steel A105	Stainless Steel SA182 Type 316
6 Nozzle Inlet/Outlet	Carbon Steel A106 Gr.B	Stainless Steel SA312 Type 316
7 Lifting Lug	Carbon Steel	Stainless Steel
8 Gasket/O-Ring ⁽²⁾	Bolted Cover: Spiral Wound Stainless Steel Quick-Open: Buna-N ⁽³⁾	Quick-Open: Buna-N ⁽³⁾
9 Basket Support	Carbon Steel A36 or A516-70	Stainless Steel A240 316
10 Straining Element ⁽²⁾	T304 SS	T304 SS
11 Drain	Carbon Steel A105	Stainless Steel SA182 Type 316
12 Vent with Plug ⁽⁴⁾	Carbon Steel A105	Stainless Steel SA182 Type 316
13 Studs	Carbon Steel A193 B7	Stainless Steel A193 B8 M
14 Nuts	Carbon Steel A194 2H	Stainless Steel A194 Gr.8
15 T-Bolt	Carbon Steel A325	Stainless Steel
16 T-Bolt Closure	Carbon Steel	Stainless Steel Type 316
17 Basket Support	Carbon Steel A36 or A516-70	Stainless Steel A240 316

1. Bill of Materials represents standard materials. Equivalent or better materials may be substituted at the manufacturer's discretion.
2. Titan recommends keeping spare parts on hand.
3. Buna-N is standard for applications below 250° F. Viton is standard for applications above 250° F.
4. 1/2" NPT is standard.

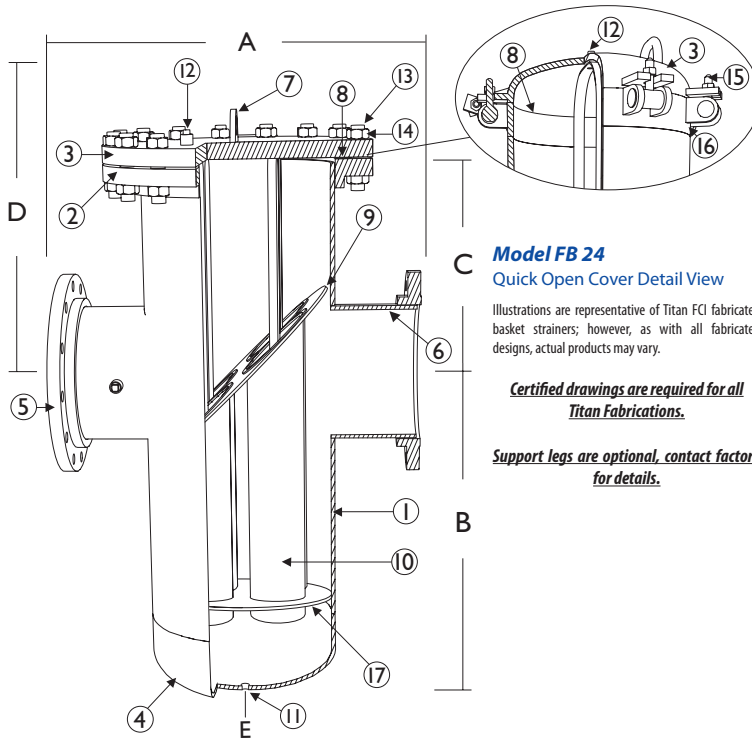

Model FB 21
Bolted Cover View

Model FB 24
Quick Open Cover Detail View

Illustrations are representative of Titan FCI fabricated basket strainers; however, as with all fabricated designs, actual products may vary.

Certified drawings are required for all Titan Fabrications.

Support legs are optional, contact factory for details.

FB 20 & FB 30 Series Basket Strainer Dimensions: 12" - 48"⁽⁴⁾ | ANSI CLASS 150, 300

DIMENSIONS AND WEIGHTS⁽¹⁾

	in	12	14	16	18	20	24	30	36	48
A - Face to Face⁽²⁾⁽⁶⁾ FB 21, FB 24, FB 31, FB 34	mm	300	355	405	460	508	610	762	914	1219
	in	34.00	40.00	44.00	44.00	50.00	66.00	66.00	84.00	96.00
	mm	864	1016	1118	1118	1270	1676	1676	2134	2438
B - Center to Bottom	in	31.00	34.00	44.00	44.00	44.00	51.00	62.00	77.00	122.00
	mm	787	864	1118	1118	1118	1295	1575	1956	3099
C - Center to Top⁽³⁾	in	20.00	22.00	22.00	22.25	24.00	32.00	34.00	34.00	45.00
	mm	508	559	559	565	610	813	864	864	1143
D - Screen Removal	in	64.00	70.00	79.00	79.00	83.00	106.00	119.00	133.00	196.00
	mm	1626	1778	2006	2006	2108	2692	3023	3378	4978
E - NPT	in	1.50	2.00	2.00	2.00	2.00	2.00	2.00	2.00	2.00
	mm	38	50	50	50	50	50	50	50	50
Approx. Weight: FB 21 Bolted (ANSI 150)	lb	1025.00	1125.00	1230.00	1600.00	2300.00	4480.00	6200.00	8400.00	14100.00
	kg	465	510	558	726	1043	2032	2812	3810	6396
Approx. Weight: FB 24 Quick Open (ANSI 150)	lb	880.00	930.00	950.00	1300.00	1760.00	3460.00	C/F	C/F	C/F
	kg	399	422	431	590	798	1569	C/F	C/F	C/F
Approx. Weight: FB 31 Bolted (ANSI 300)	lb	1780.00	1850.00	2100.00	2960.00	4625.00	7500.00	C/F	C/F	C/F
	kg	807	839	953	1343	2098	3402	C/F	C/F	C/F
Approx. Weight: FB 34 Quick Open (ANSI 300)	lb	1425.00	1430.00	1450.00	2265.00	3220.00	5200.00	C/F	C/F	C/F
	kg	646	649	658	1028	1461	2359	C/F	C/F	C/F

1. Dimensions and weights of the FB 21, FB 24, FB 31, FB 34 are provided for reference only. Certified drawings are required for all Titan Fabrications.
2. Face to face values have a tolerance of ±0.06 in (±0.06 mm) for sizes 10" and lower and a tolerance of ±0.12 in (±0.12 mm) for sizes 12" and larger.
3. Centerline dimension is from the top of body flange. Does not include cover. Quick open cover dimension is to the top of body housing.

4. Smaller sizes are available. Please consult page 6 of catalog.
5. Centerline to bottom dimension is to bottom of body housing and does not include the NPT plug.
6. Face to face dimension listed are for flanged units only. Please call factory for more information.

Titan FCI's fabricated products are made to each customer's unique specifications. Dimensions, materials, and all other product details referenced in this literature are general in nature. Some options may not be available in all sizes and/or models. Titan FCI reserves the right to make design and specification changes to improve the products without prior notification.

For exact product specifications, please consult the Titan FCI factory and request certified engineering documents.

FABRICATED BASKET STRAINERS

2" - 12" | ANSI CLASS 600, 900

Fabricated Basket strainers are required when an off-the-shelf solution will not meet your exact piping requirements. All of our Fabricated Strainers are made right here in the USA, at our state-of-the-art facility in the southeastern part of North Carolina.



8" Fabricated Basket Strainer, ANSI 600, with Optional Davit Assembly shown

CUSTOM COVER SOLUTIONS INCLUDING DAVITS & HINGED COVER

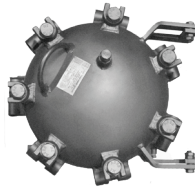

HINGED

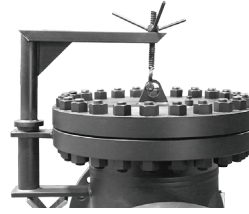

DAVIT



BOLTED

MODELS

- FB 40 Series - 600 Class**
- FB 50 Series - 900 Class**

MATERIALS:

- Carbon Steel • Stainless Steel
- Other Alloys

OPTIONS



- Gauge Taps
- Vent/drains - (Standard)
- Back Flush Valves
- Semi-Automatic
- Pressure Gauges
- DP Gauge Switch
- Support Legs



ANSI CLASSES

ANSI Class 150 up to high pressure 900 class



STRAINING ELEMENTS

Customize to fit your requirements
Heavy Duty Baskets, Wedge Wire, & Multi Basket Designs



END CONNECTIONS

Flanged, Raised Face, RTJ, Butt Weld, Socket Weld, Threaded

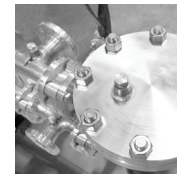

SANITARY

Sanitary Application Designs for food/pharmaceutical processing



TEMPERATURE CONTROL

Steam Jacket casing for set temperature control



UNIQUE PROJECTS

Rotated and Offset Nozzles to fit into your applications



290 Corporate Dr
www.titanfci.com
Phone: 910.735.0000

Lumberton, NC 28358
titan@titanfci.com
Fax: 910.738.3848

2" - 12"

FB 40 & FB 50 Series
Basket Strainer

ANSI Class
600, 900

BILL OF MATERIALS⁽¹⁾
FB 40 & FB 50 Series

Part	FB 40 & FB 50 Carbon Steel	FB 40 & FB 50 Stainless Steel
1 Body	Carbon Steel A106 Gr.B	Stainless Steel SA312 Type 316
2 Body Flange	Carbon Steel A105	Stainless Steel SA182 Type 316
3 Cover	Bolted: Carbon Steel A105 Quick-Open: Carbon Steel A516 Gr. 70	Bolted: Stainless Steel SA182 Type 316 Quick-Open: Stainless Steel Type 316
4 Pipe Cap	Carbon Steel A234 Gr.WPB	Stainless Steel SA403 Type 316
5 Inlet/Outlet Flange	Carbon Steel A105	Stainless Steel SA182 Type 316
6 Nozzle Inlet/Outlet	Carbon Steel A106 Gr.B	Stainless Steel SA312 Type 316
7 Lifting Lug	Carbon Steel	Stainless Steel
8 Gasket/O-Ring ⁽²⁾	Bolted Cover: Spiral Wound Stainless Steel Quick-Open: Buna-N ⁽³⁾	
9 Basket Support	Carbon Steel A36 or A516-70	Stainless Steel A240 316
10 Straining Element ⁽²⁾	T304 SS	T304 SS
11 Drain	Carbon Steel A105	Stainless Steel SA182 Type 316
12 Vent with Plug ⁽⁴⁾	Carbon Steel A105	Stainless Steel SA182 Type 316
13 Studs	Carbon Steel A193 B7	Stainless Steel A193 B8 M
14 Nuts	Carbon Steel A194 2H	Stainless Steel A194 Gr.8
15 T-Bolt	Carbon Steel A325	Stainless Steel
16 T-Bolt Closure	Carbon Steel	Stainless Steel Type 316

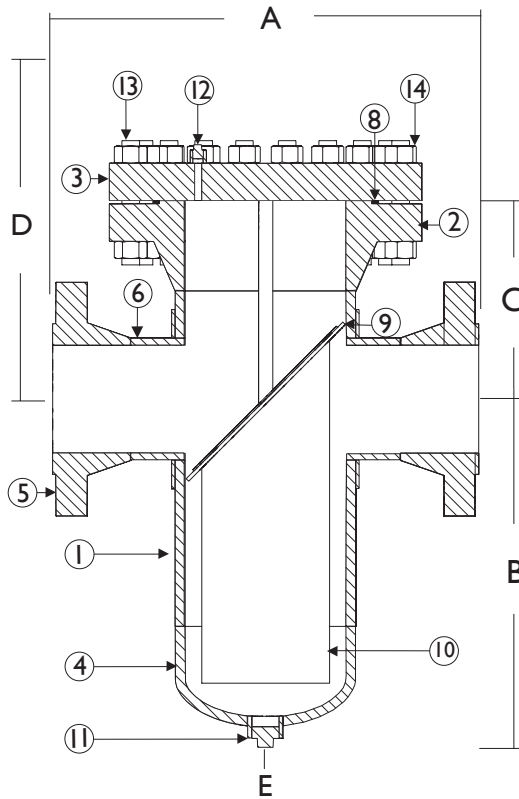

Illustrations are representative of Titan FCI fabricated tee strainers; however, as with all fabricated designs, actual products may vary.

High pressure quick open threaded and yoke style covers available upon request.

Certified drawings are required for all Titan Fabrications.

Support legs are optional, contact factory for details.

Model FB 41
Bolted Cover View

- Bill of Materials represents standard materials. Equivalent or better materials may be substituted at the manufacturer's discretion.
- Titan recommends keeping spare parts on hand.
- Buna-N is standard for applications below 250° F. Viton is standard for applications above 250° F.
- 1/2" NPT is standard. NPT Blow-off not recommended for ANSI Class 900 and above.

FB 40 & FB 50 Series Basket Strainer Dimensions: 2" - 12" | ANSI CLASS 600, 900

DIMENSIONS AND WEIGHTS⁽¹⁾

	in	2	2 1/2	3	4	5	6	8	10	12 ⁽⁴⁾
A - Face to Face⁽²⁾⁽⁷⁾ FB 41, FB 44, FB 51, FB 54	mm	50	65	80	100	125	150	200	250	300
	in	22.00	C/F	22.00	26.00	C/F	30.00	34.00	42.00	44.00
	mm	559	C/F	559	660	C/F	762	864	1067	1118
B - Center to Bottom⁽⁵⁾	in	10.00	C/F	12.00	16.00	C/F	21.00	30.00	36.00	31.00
	mm	254	C/F	305	406	C/F	533	762	914	787
C - Center to Top⁽³⁾	in	8.00	C/F	10.00	11.00	C/F	12.00	14.00	18.00	20.00
	mm	203	C/F	254	279	C/F	305	356	457	508
D - Screen Removal	in	24.00	C/F	30.00	35.00	C/F	41.00	53.00	66.00	64.00
	mm	610	C/F	762	889	C/F	1041	1346	1676	1626
E- NPT⁽⁶⁾	in	.75	C/F	.75	1.00	C/F	1.00	1.50	1.50	1.50
	mm	19	C/F	19	25	C/F	25	38	38	38
Approx. Weight: FB 41 Bolted (ANSI 600)	lb	290	C/F	400	550	C/F	850	1200	2150	2700
	kg	131.5	C/F	181.44	249.5	C/F	385.6	544.3	975.2	1224.7
Approx. Weight: FB 51 Bolted (ANSI 900)	lb	375	C/F	450	700	C/F	1150	1750	3100	4100
	kg	170.1	C/F	204.1	317.5	C/F	521.6	793.8	1406.1	1859.8

- Dimensions and weights of the FB 41, FB 44, FB 51, FB 54 are provided for reference only. Certified drawings are required for all Titan Fabrications.
- Face to face values have a tolerance of ±0.06 in (±2.0 mm) for sizes 10" and lower and a tolerance of ±0.12 in (±3.0 mm) for sizes 12" and larger.
- Centerline dimension is from the top of body flange. Does not include cover. Quick open cover dimension is to the top of body housing.
- 12" strainers are multi basket style.
- Centerline to bottom dimension is to bottom of body housing and does not include the NPT plug.
- NPT Blow-off not recommended for ANSI Class 900 and above.
- Face to face dimension listed are for flanged units only. Please call factory for more information.

Titan FCI's fabricated products are made to each customer's unique specifications. Dimensions, materials, and all other product details referenced in this literature are general in nature. Some options may not be available in all sizes and/or models. Titan FCI reserves the right to make design and specification changes to improve the products without prior notification.

For exact product specifications, please consult the Titan FCI factory and request certified engineering documents.

FABRICATED INLINE DUPLEX STRAINERS

2" - 24" | ANSI CLASS 150, 300

LARGER SIZES AVAILABLE

Fabricated Duplex strainers are required when an off-the-shelf solution will not meet your exact piping requirements. All of our Fabricated Strainers are made right here in the USA, at our state-of-the-art facility in the southeastern part of North Carolina.

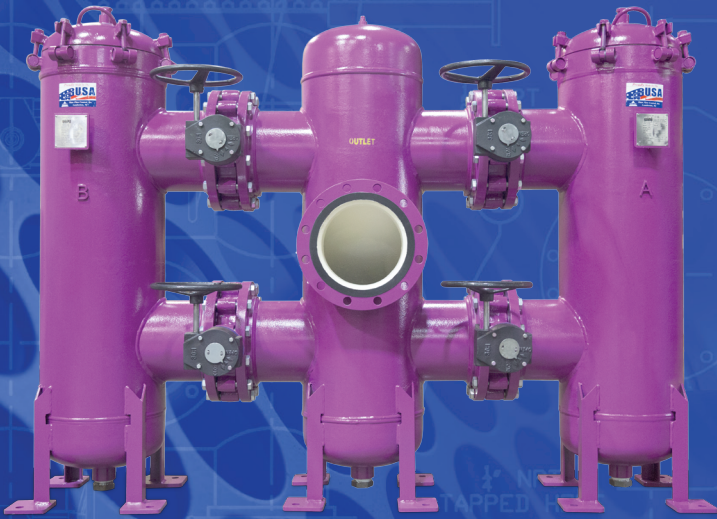

20" Fabricated Duplex Strainer with Internal Epoxy Coating shown

Sizes 2" - 24"
Contact Factory for Larger Sizes

CUSTOM COVER SOLUTIONS INCLUDING DAVITS & HINGED COVER



HINGED

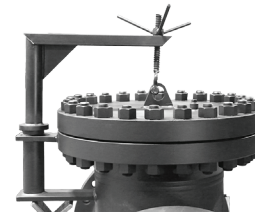

DAVIT



BOLTED

MODELS

FDI 20 Series - 150 Class
FDI 30 Series - 300 Class

MATERIALS:

- Carbon Steel • Stainless Steel
- Other Alloys

OPTIONS



- Gauge Taps
- Vent/drains - (Standard)
- Back Flush Valves
- Semi-Automatic
- Pressure Gauges
- DP Gauge Switch
- Support Legs



ANSI CLASSES
ANSI Class 150
up to high pressure
600 class



STRAINING ELEMENTS
Customize to fit your requirements
Heavy Duty Baskets, Wedge Wire, & Multi Basket Designs



END CONNECTIONS
Flanged, Raised Face, RTJ, Butt Weld, Socket Weld, Threaded

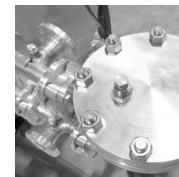

SANITARY
Sanitary Application Designs for food/pharmaceutical processing



TEMPERATURE CONTROL
Steam Jacket casing for set temperature control



UNIQUE PROJECTS
Rotated and Offset Nozzles to fit into your applications



290 Corporate Dr
www.titanfci.com
Phone: 910.735.0000

Lumberton, NC 28358
titan@titanfci.com
Fax: 910.738.3848

2" - 24"

FDI 20 & FDI 30 Series
Duplex Strainer

ANSI Class
150, 300

BILL OF MATERIALS⁽¹⁾
FDI 20 & FDI 30 Series

Part	FDI 20 & FDI 30 Carbon Steel	FDI 20 & FDI 30 Stainless Steel
1 Column Body	Carbon Steel A106 Gr.B	Stainless Steel SA312 Type 316
2 Basket Housing Body	Carbon Steel A234	Stainless Steel SA312 Type 316
3 Body Flange	Carbon Steel A105	Stainless Steel SA182 Type 316
4 Cover	Bolted: Carbon Steel A105 Quick-Open: Carbon Steel A516 Gr.70	Bolted: Stainless Steel SA182 Type 316 Quick-Open: Stainless Steel Type 316
5 Pipe Cap	Carbon Steel A234	Stainless Steel SA 403 Type 316
6 Inlet/Outlet Flange	Carbon Steel A105	Stainless Steel SA182 Type 316
7 Nozzle Inlet/Outlet	Carbon Steel A106 Gr.B	Stainless Steel SA312 Type 316
8 Lifting Lug	Carbon Steel	Stainless Steel
9 Gasket/O-Ring ⁽²⁾	Bolted Cover: Spiral Wound Stainless Steel Quick-Open: Buna-N ⁽³⁾	
10 Butterfly Valve	Butterfly Valve: BF 76 Ductile Iron Body, Ductile Iron Nickel Coated Disc ⁽⁵⁾ , Buna/EPDM Seat with Gear Operator	
11 Straining Element ⁽²⁾	T304 SS	T304 SS
12 Drain	Carbon Steel A105	Stainless Steel SA182 Type 316
13 Vent with Plug ⁽⁶⁾	Carbon Steel A105	Stainless Steel SA182 Type 316
14 Studs	Carbon Steel A193 B7	Stainless Steel A193 B8 M
15 Nuts	Carbon Steel A194 2H	Stainless Steel A194 Gr.8
16 T-Bolt	Carbon Steel S A325	Stainless Steel
17 T-Bolt Closure	Carbon Steel	Stainless Steel Type 316
18 Support Legs ⁽⁶⁾	Carbon Steel	Stainless Steel

1. Bill of Materials represents standard materials. Equivalent or better materials may be substituted at the manufacturer's discretion.
2. Titan recommends keeping spare parts on hand.
3. Buna-N is standard for applications below 250° F. Viton is standard for applications above 250° F.
4. 1/2" NPT is standard
5. Stainless Steel discs are used for applications requiring all stainless parts.
6. Support legs are optional. Call factory.

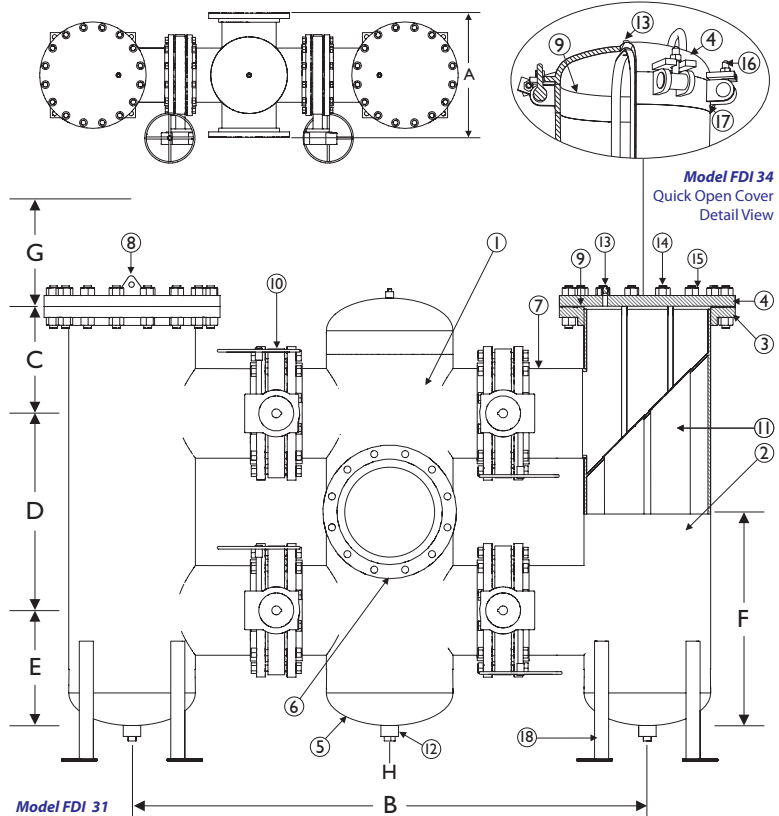

Illustrations are representative of Titan FCI fabricated duplex strainers; however, as with all fabricated designs, actual products may vary. Illustration is representative of multi-basket style (sizes 12" and up). 2" - 10" are single basket style.

Certified drawings are required for all Titan fabrications. Support legs are optional, contact factory for details.

FDI 20 & FDI 30 Series Inline Duplex Strainer Dimensions: 2" - 24" | ANSI CLASS 150, 300

DIMENSIONS AND WEIGHTS⁽¹⁾

	in	2	3	4	6	8	10	12	14	16	18	20	24
A - Face to Face ⁽²⁾ FDI 21, FDI 24, FDI 31, FDI 34	mm	50	80	100	125	150	200	250	350	400	450	500	600
	in	10.25	12.50	14.50	18.50	22.25	25.25	29.25	32.25	34.25	38.25	41.63	46.25
	mm	260	318	368	470	565	641	743	819	870	972	1057	1175
B - Center Column to Center Column	in	32.18	34.63	43.25	49.63	55.75	62.44	73.25	78.25	85.00	90.50	101.88	114.13
	mm	817	880	1099	12.61	1416	1586	1861	1988	2159	2299	2588	2899
C - Center of Top Valve to Top ⁽³⁾	in	6.63	7.25	8.75	10.00	11.25	13.25	15.19	15.75	18.19	18.19	23.13	27.06
	mm	168	184	222	254	286	337	386	400	462	462	588	687
D - Valve to Valve	in	13.00	13.00	17.00	17.00	21.00	25.00	28.00	30.00	34.00	36.00	40.00	48.00
	mm	330	330	432	432	533	635	711	762	864	914	1016	1219
E - Center of Bottom Valve to Bottom	in	6.69	6.63	8.25	10.31	12.31	14.38	16.38	18.00	20.50	21.50	22.50	24.50
	mm	170	168	210	262	313	365	416	457	521	546	572	622
F - Centerline to Bottom ⁽⁴⁾	in	13.19	13.13	16.75	18.81	22.81	26.88	30.38	33.00	37.50	39.50	42.50	48.50
	mm	335	334	426	478	580	683	772	838	953	1003	1080	1232
G - Screen Removal	in	24.00	25.00	32.00	34.00	40.00	47.00	53.00	56.00	64.00	67.00	77.00	91.00
	mm	610	635	813	864	1016	1194	1346	1422	1626	1702	1956	2311
H - NPT	in	.75	.75	1.00	1.00	1.50	1.50	1.50	2.00	2.00	2.00	2.00	2.00
	mm	19	19	25	25	38	38	38	51	51	51	51	51
Approximate Weight	lb	370.00	450.00	690.00	1100.00	1750.00	2550.00	4260.00	4325.00	6100.00	6500.00	10150.00	14750.00
	kg	168.00	204.00	313.00	499.00	794.00	1157.00	1932.00	1962.00	2767.00	2948.00	4604.00	6691.00

1. Dimensions and weights of FDI 20 & FDI 30 are provided for reference only. Certified drawings are required for all Titan fabrications.
2. Face to face values have a tolerance of ±0.06 in (±0.06 mm) for sizes 10" and lower and a tolerance of ±0.12 in (±3.0 mm) for sizes 12" and larger.
3. Centerline dimension is from the top of body housing. Does not include cover. Quick open cover dimension is to the top of body housing.
4. Centerline to bottom dimension is to bottom of body housing and does not include the NPT plug.

Titan FCI's fabricated products are made to each customer's unique specifications. Dimensions, materials, and all other product details referenced in this literature are general in nature. Some options may not be available in all sizes and/or models. Titan FCI reserves the right to make design and specification changes to improve the products without prior notification.

For exact product specifications, please consult the Titan FCI factory and request certified engineering documents.

FABRICATED OFFSET DUPLEX STRAINERS

2" - 24" | ANSI CLASS 150, 300

LARGER SIZES AVAILABLE

Fabricated Duplex strainers are required when an off-the-shelf solution will not meet your exact piping requirements. All of our Fabricated Strainers are made right here in the USA, at our state-of-the-art facility in the southeastern part of North Carolina.

CUSTOM COVER SOLUTIONS INCLUDING DAVITS & HINGED COVER

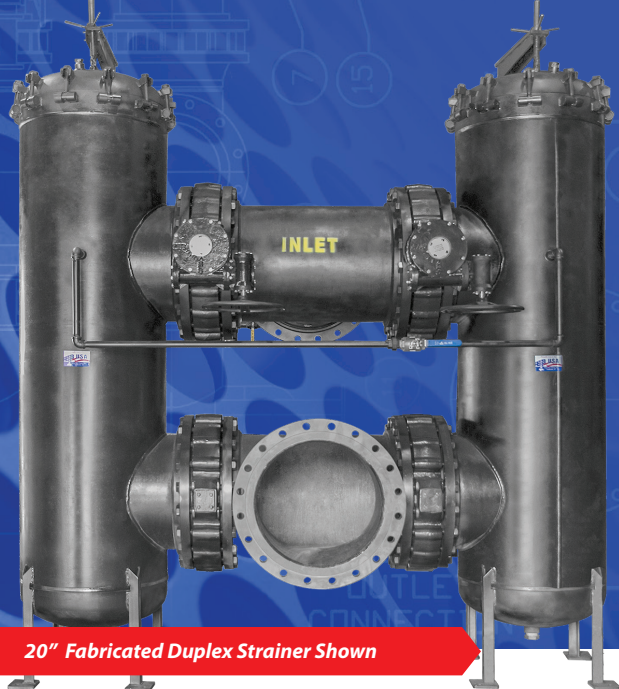

20" Fabricated Duplex Strainer Shown

Sizes 2" - 24"
Contact Factory for Larger Sizes

MODELS

FDO 20 Series - 150 Class
FDO 30 Series - 300 Class

MATERIALS:

- Carbon Steel • Stainless Steel
- Other Alloys

OPTIONS



- Gauge Taps
- Vent/drains - (Standard)
- Back Flush Valves
- Semi-Automatic
- Pressure Gauges
- DP Gauge Switch
- Support Legs



HINGED

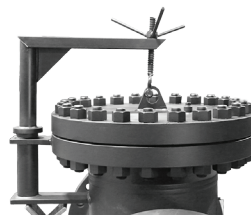

DAVIT



BOLTED



ANSI CLASSES
ANSI Class 150
up to high pressure
600 class



STRAINING ELEMENTS
Customize to fit your requirements

Heavy Duty Baskets,
Wedge Wire, & Multi
Basket Designs



END CONNECTIONS
Flanged, Raised Face,
RTJ, Butt Weld, Socket
Weld, Threaded

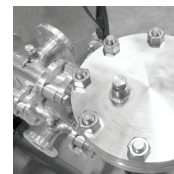

SANITARY
Sanitary Application
Designs for
food/pharmaceutical
processing



TEMPERATURE CONTROL
Steam Jacket
casing for set
temperature
control



UNIQUE PROJECTS
Rotated and Offset
Nozzles to fit into
your applications



290 Corporate Dr
www.titanfci.com
Phone: 910.735.0000

Lumberton, NC 28358
titan@titanfci.com
Fax: 910.738.3848

2"- 24" FDO 20 & FDO 30 Series
Duplex Strainer

ANSI Class
150, 300

BILL OF MATERIALS⁽¹⁾
FDO 20 & FDO 30 Series

Part	FDO 20 & FDO 30 Carbon Steel	FDO 20 & FDO 30 Stainless Steel
1 Body	Carbon Steel A106 Gr.B	Stainless Steel SA312 Type 316
2 Tee	Carbon Steel A234	Stainless Steel SA403 Type 316
3 Nozzle	Carbon Steel A106 Gr.B	Stainless Steel SA312 Type 316
4 Cover	Bolted: Carbon Steel A105 Quick-Open: Carbon Steel A516 Gr. 70	Bolted: Stainless Steel SA182 Type 316 Quick-Open: Stainless Steel Type 316
5 Body Flange	Carbon Steel A105	Stainless Steel SA182 Type 316
6 Inlet/Outlet Flange	Carbon Steel A105	Stainless Steel SA182 Type 316
7 Pipe Cap	Carbon Steel A234 Gr.WPB	Stainless Steel SA403 Type 316
8 Straining Element ⁽²⁾	T304 SS	T304 SS
9 Gasket/O-Ring ⁽²⁾	Bolted Cover: Spiral Wound Stainless Steel Quick-Open: Buna-N ⁽³⁾	Quick-Open: Buna-N ⁽³⁾
10 Lifting Lug	Carbon Steel	Stainless Steel
11 Butterfly Valve	Butterfly Valve: BF 76 Ductile Iron Body, Ductile Iron Nickel Coated Disc ⁽⁵⁾ , Buna/EPDM Seat with Gear Operator	
12 Drain	Carbon Steel A105	Stainless Steel SA182 Type 316
13 Vent with Plug ⁽⁴⁾	Carbon Steel A105	Stainless Steel SA182 Type 316
14 Studs	Carbon Steel A193 B7	Stainless Steel A193 B8 M
15 Nuts	Carbon Steel A194 2H	Stainless Steel A194 Gr.8
16 T-Bolt	Carbon Steel S A325	Stainless Steel
17 T-Bolt Closure	Carbon Steel	Stainless Steel Type 316
18 Support Legs ⁽⁶⁾	Carbon Steel	Stainless Steel

1. Bill of Materials represents standard materials. Equivalent or better materials may be substituted at the manufacturer's discretion.
2. Titan recommends keeping spare parts on hand.
3. Buna-N is standard for applications below 250°F. Viton is standard for applications 250°F and above.
4. 1/2" NPT is standard.
5. Stainless Steel discs are used for applications requiring all stainless parts.
6. Support legs are optional. Call factory.

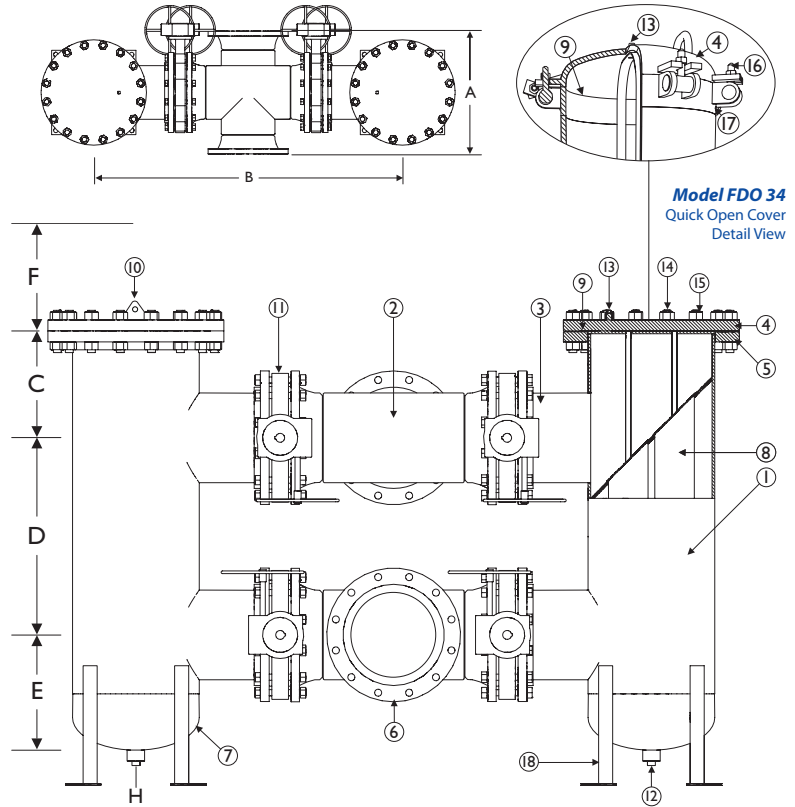

Model FDO 31

Illustrations are representative of Titan FCI fabricated duplex strainers; however, as with all fabricated designs, actual products may vary. Illustration is representative of multi-basket style (sizes 12" and up). 2" - 10" are single basket style.

Certified drawings are required for all Titan fabrications. Support legs are optional, contact factory for details.

FDO 20 & FDO 30 Series Offset Duplex Strainer Dimensions: 2" - 24" | ANSI CLASS 150, 300

DIMENSIONS AND WEIGHTS⁽¹⁾

	in	2	3	4	6	8	10	12	14	16	18	20	24
A - Face to Face ⁽²⁾ FDO 21, FDO 24, FDO 31, FDO 34	mm	50	80	100	125	150	200	250	350	400	450	500	600
B - Center Column to Center Column	in	10.25	12.50	14.50	18.50	22.25	25.25	29.25	32.25	34.25	38.25	41.63	46.25
	mm	260	318	368	470	565	641	743	819	870	972	1057	1175
C - Center of Top Valve to top ⁽³⁾	in	32.18	34.63	43.25	49.63	55.75	62.44	73.25	78.25	85.00	90.50	101.88	114.13
	mm	817	880	1099	1261	1416	1586	1861	1988	2159	2299	2588	2899
D - Valve to Valve	in	6.63	7.25	8.75	10.00	11.25	13.25	15.19	15.75	18.19	18.19	23.13	27.06
	mm	168	184	222	254	286	337	386	400	462	462	588	687
E - Center of Bottom Valve to Bottom ⁽⁴⁾	in	13.00	13.00	17.00	17.00	21.00	25.00	28.00	30.00	34.00	36.00	40.00	48.00
	mm	330	330	432	432	533	635	711	762	864	914	1016	1219
F - Screen Removal	in	6.69	6.63	8.25	10.31	12.31	14.38	16.38	18.00	20.50	21.50	22.50	24.50
	mm	170	168	210	262	313	365	416	457	521	546	572	622
H - NPT	in	24.00	25.00	32.00	34.00	40.00	47.00	53.00	56.00	64.00	67.00	77.00	91.00
	mm	610	635	813	864	1016	1194	1346	1422	1626	1702	1956	2311
Approximate Weight	in	.75	.75	1.00	1.00	1.50	1.50	1.50	2.00	2.00	2.00	2.00	2.00
	mm	19	19	25	25	38	38	38	51	51	51	51	51
	lb	370.00	450.00	690.00	1100.00	1750.00	2550.00	4100.00	4300.00	6100.00	6500.00	9950.00	15250.00
	kg	168.00	204.00	313.00	499.00	794.00	1157.00	1860.00	1951.00	2767.00	2948.00	4513.00	6917.00

1. Dimensions and weights of FDO 20 & FDO 30 are provided for reference only. Certified drawings are required for all Titan Fabrications.
2. Face to face values have a tolerance of ±0.06 in (±0.2 mm) for sizes 10" and lower and a tolerance of ±0.12 in (±3.0 mm) for sizes 12" and larger.
3. Centerline dimension is from the top of body housing. Does not include cover. Quick open cover dimension is to the top of body housing.
4. Center of Bottom Valve to Bottom dimension is to bottom of body housing and does not include the NPT plug.

Titan FCI's fabricated products are made to each customer's unique specifications. Dimensions, materials, and all other product details referenced in this literature are general in nature. Some options may not be available in all sizes and/or models. Titan FCI reserves the right to make design and specification changes to improve the products without prior notification. **For exact product specifications, please consult the Titan FCI factory and request certified engineering documents.**

FABRICATED TEE STRAINERS

2" - 30" | ANSI CLASS 150



Fabricated Tee Strainers are required when an off-the-shelf solution will not meet your exact piping requirements. All of our Fabricated Strainers are made right here in the USA, at our state-of-the-art facility in the southeastern part of North Carolina.

6" Fabricated Tee Strainer, ANSI 150, with Quick Open Cover Shown

CUSTOM COVER SOLUTIONS INCLUDING DAVITS & HINGED COVER

Sizes 2" - 30" Available

MODEL

FT 20 Series - 150 Class

MATERIALS:

- Carbon Steel • Stainless Steel
- Other Alloys

OPTIONS



- Gauge Taps
- Vent - (Standard)
- Drains
- Back Flush Valves
- Semi-Automatic
- Pressure Gauges
- DP Gauge Switch

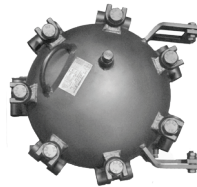

HINGED

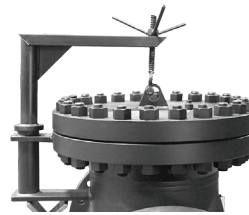

DAVIT



BOLTED



ANSI CLASSES

ANSI Class 150 up to high pressure 900 class



STRAINING ELEMENTS

Customize to fit your requirements
Heavy Duty Baskets



END CONNECTIONS

Flanged, Raised Face, RTJ, Butt Weld, Socket Weld, Threaded



SANITARY

Sanitary Application Designs for food/pharmaceutical processing



TEMPERATURE CONTROL

Steam Jacket casing for set temperature control



UNIQUE PROJECTS

Rotated and Offset Nozzles to fit into your applications



290 Corporate Dr
www.titanfci.com
Phone: 910.735.0000

Lumberton, NC 28358
titan@titanfci.com
Fax: 910.738.3848

2" - 30"

FT 20 Series
Tee Strainer

ANSI Class
150

BILL OF MATERIALS⁽¹⁾
FT 20 Series

Part	FT 20 - 25 CS	FT 20 - 25 SS
1 Body	Carbon Steel A234 Gr.WPB	Stainless Steel SA403
2 Cover	Carbon Steel A105	Stainless Steel SA182 Type 316
3 Quick Open Cover Assembly	Carbon Steel A516 Gr.70	Stainless Steel Type 316
4 Cover Gasket/ O-Ring ⁽²⁾	Bolted: Spiral Wound Stainless Steel	Quick Open: Buna-N ⁽³⁾
5 Straining Element ^{(2)(4) (5)}	T304 SS	T304 SS
6 Inlet/Outlet Flange	Carbon Steel A105	Stainless Steel SA182 Type 316
7 Weld Neck Flange	Carbon Steel A105	Stainless Steel SA182 Type 316
8 Bolts	Carbon Steel A193-B7	Stainless Steel A193 B8 M
9 Nuts	Carbon Steel A194 2H	Stainless Steel A194 Gr.8
10 T-Bolt	Carbon Steel A325	Stainless Steel
11 Vent with Plug ⁽⁶⁾	Carbon Steel A105	Stainless Steel SA182 Type 316

- Bill of Materials represents standard materials. Equivalent or better materials may be substituted at the manufacturer's discretion.
- Titan recommends keeping spare parts on hand.
- Buna-N is standard for applications below 250° F. Viton is standard for applications above 250° F.
- Max mesh size available is 60 mesh.
- 1/8" perf is standard for all mesh lined straining elements.
- 1/2" NPT is standard

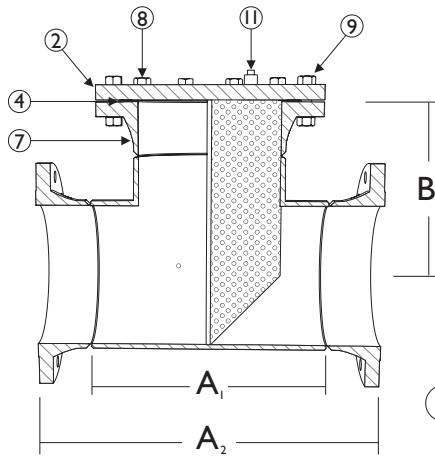

Model FT 21

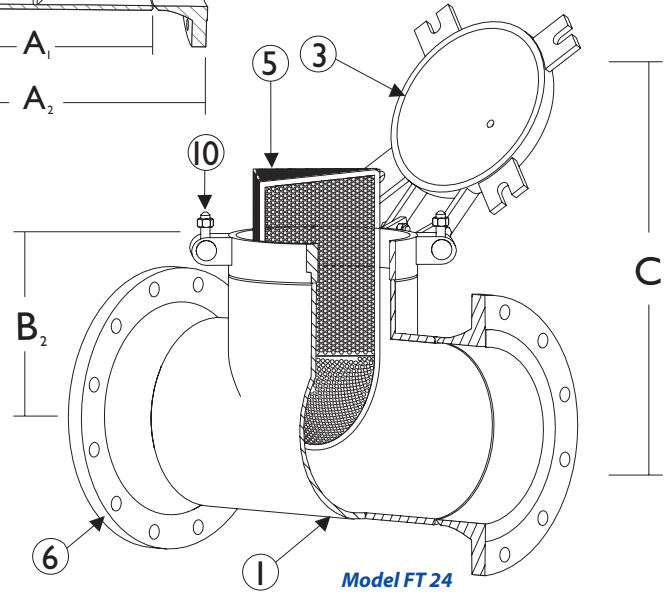

Illustrations are representative of Titan FCI fabricated tee strainers; however, as with all fabricated designs, actual products may vary. **Certified drawings are required for all Titan fabrications.**

Tee Strainers are not recommended for suction applications.

Optional bottom drains (2" NPT Standard) are available at extra cost.

FT 20 Series: Tee Strainer Dimensions | 2" - 30" | ANSI CLASS 150

DIMENSIONS AND WEIGHTS⁽¹⁾

	in	2	2 1/2	3	4	5	6	8	10	12	14	16	18	20	24	30
(A₁) Face to Face ⁽²⁾ FT 20, FT 23 - Butt-Weld	mm	50	65	80	100	125	150	200	250	300	355	405	460	508	610	762
	in	5.00	6.00	6.75	8.25	9.75	11.25	14.00	17.00	20.00	22.00	24.00	27.00	30.00	34.00	44.00
(A₂) Face to Face ⁽²⁾ FT 21, FT 24 - Flanged	mm	127	152	172	210	248	286	356	432	508	559	610	686	762	864	1118
	in	10.25	11.75	12.50	14.50	17.00	18.50	22.25	25.25	29.25	32.25	34.25	38.25	41.63	46.25	54.50
(B₁) Ctr-Line to Top ⁽³⁾ FT 20 - FT 22 - Bolted Cover	mm	130	149	159	184	216	235	283	321	372	410	435	486	529	587	692
	in	5.13	5.88	6.25	7.25	8.50	9.25	11.13	12.63	14.63	16.13	17.13	19.13	20.81	23.13	27.25
(B₂) Ctr-Line to Top ⁽³⁾ FT 23 - FT 25 - Quick Open Cover	mm	n/a	n/a	n/a	n/a	n/a	243	294	354	403	446	482	546	608	692	857
	in	n/a	n/a	n/a	n/a	n/a	9.56	11.56	13.94	15.88	17.56	19.00	21.50	23.94	27.25	33.75
C Dimension Screen Removal	mm	291	335	362	426	503	554	675	778	905	997	1073	1200	1311	1480	1765
	in	11.44	13.19	14.25	16.75	19.78	21.81	26.56	30.63	35.63	39.25	42.25	47.25	51.63	58.25	69.50
Approx. Weight: FT 20	lb	18.13	C/F	34.38	56.88	C/F	108.75	178.75	246.25	413.75	523.75	643.75	666.25	1030.00	1532.50	C/F
	kg	8.22	C/F	15.60	25.80	C/F	49.33	81.08	111.70	187.70	237.60	292.00	302.21	467.00	695.13	C/F
Approx. Weight: FT 21	lb	33.13	C/F	63.13	98.13	C/F	173.75	283.75	381.25	633.75	808.75	993.75	1078.75	1522.50	2202.50	C/F
	kg	15.00	C/F	28.63	44.51	C/F	78.81	128.71	172.93	287.50	366.84	450.80	489.31	690.60	999.10	C/F

- Dimensions and weights of the FT 20 series are provided for reference only. Certified drawings are required for all Titan fabrications.
- Face to face values have a tolerance of ±0.06 in (±2.0 mm) for sizes 10" and lower and a tolerance of ±0.12 in (±3.0 mm) for sizes 12" and larger.
- Center line to top dimension is to the top of the body flange. Quick open cover dimension is to the top of body housing.

Titan FCI's fabricated products are made to each customer's unique specifications. Dimensions, materials, and all other product details referenced in this literature are general in nature. Some options may not be available in all sizes and/or models. Titan FCI reserves the right to make design and specification changes to improve the products without prior notification.

For exact product specifications, please consult the Titan FCI factory and request certified engineering documents.

FABRICATED TEE STRAINERS

2" - 30" | ANSI CLASS 300



Fabricated Tee Strainers are required when an off-the-shelf solution will not meet your exact piping requirements. All of our Fabricated Strainers are made right here in the USA, at our state-of-the-art facility in the southeastern part of North Carolina.

18" Fabricated Tee Strainer, ANSI 300, with Optional Davit Assembly Shown

CUSTOM COVER SOLUTIONS INCLUDING DAVITS & HINGED COVER

Sizes 2" - 30"
Available

MODEL

FT 30 Series - 300 Class

MATERIALS:

- Carbon Steel • Stainless Steel
- Other Alloys

OPTIONS



- Gauge Taps
- Vent - (Standard)
- Drains
- Back Flush Valves
- Semi-Automatic
- Pressure Gauges
- DP Gauge Switch

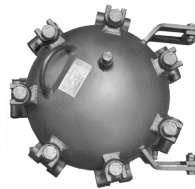

HINGED

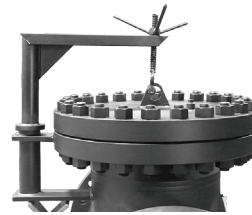

DAVIT



BOLTED



ANSI CLASSES

ANSI Class 150
up to high pressure
900 class



STRAINING ELEMENTS

Customize to fit your
requirements
Heavy Duty Baskets



END CONNECTIONS

Flanged, Raised Face,
RTJ, Butt Weld, Socket
Weld, Threaded



SANITARY

Sanitary Application
Designs for
food/pharmaceutical
processing



TEMPERATURE CONTROL

Steam Jacket casing
for set temperature
control



UNIQUE PROJECTS

Rotated and Offset
Nozzles to fit into
your applications



290 Corporate Dr
www.titanfci.com
Phone: 910.735.0000

Lumberton, NC 28358
titan@titanfci.com
Fax: 910.738.3848

2" - 30"

FT 30 Series
Tee Strainer

ANSI Class
300

BILL OF MATERIALS ⁽¹⁾
FT 30 Series

Part	FT 30-35 CS	FT 30-35 SS
1 Body	Carbon Steel A234 Gr.WPB	Stainless Steel SA 403
2 Cover	Carbon Steel A105	Stainless Steel SA182 Type 316
3 Quick Open Cover Assembly	Carbon Steel A516 Gr.70	Stainless Steel Type 316
4 Cover Gasket/O-Ring ⁽²⁾	Bolted: Spiral Wound Stainless Steel	Quick Open: Buna-N ⁽³⁾
5 Straining Element ⁽²⁾⁽⁴⁾⁽⁵⁾	T304 SS	T304 SS
6 Inlet/Outlet Flange	Carbon Steel A105	Stainless Steel SA182 Type 316
7 Weld Neck Flange	Carbon Steel A105	Stainless Steel SA182 Type 316
8 Bolts	Carbon Steel A193-B7	Stainless Steel A193 B8 M
9 Nuts	Carbon Steel A194 2H	Stainless Steel A194 Gr.8
10 T-Bolt	Carbon Steel A325	Stainless Steel
11 Vent with Plug ⁽⁶⁾	Carbon Steel A105	Stainless Steel SA182 Type 316

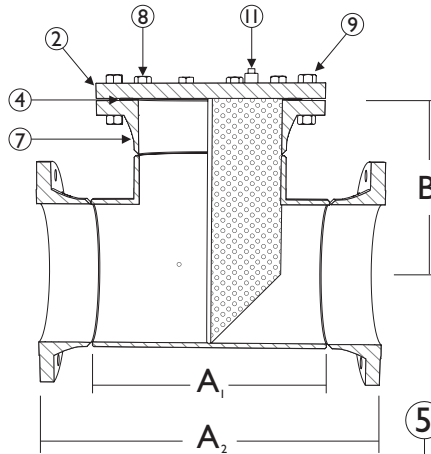

Model FT 31

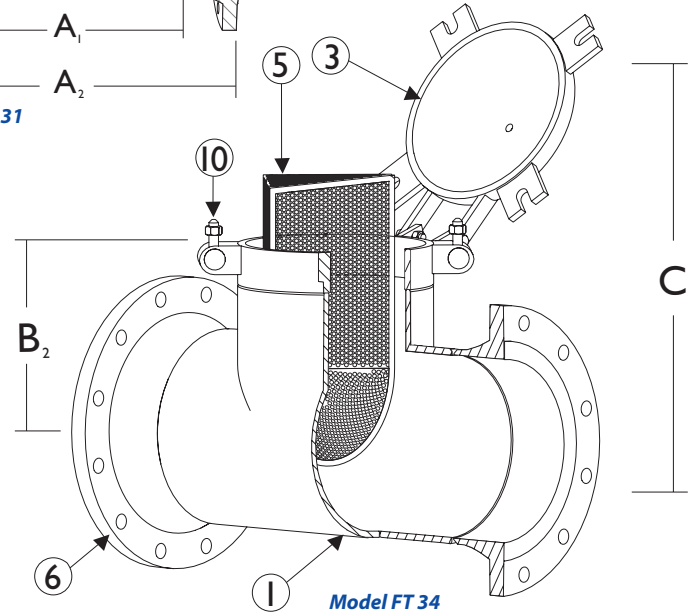

Illustrations are representative of Titan FCI fabricated tee strainers; however, as with all fabricated designs, actual products may vary. Certified drawings are required for all Titan Fabrications.

Tee Strainers are not recommended for suction applications.

Optional bottom drains (2" NPT Standard) are available at extra cost.

1. Bill of Materials represents standard materials. Equivalent or better materials may be substituted at the manufacturer's discretion.
2. Titan recommends keeping spare parts on hand.
3. Buna-N is standard for applications below 250° F. Viton is standard for applications above 250° F.
4. Max mesh size available is 60 mesh.
5. 1/8" perf is standard for all mesh lined straining elements.
6. 1/2" NPT is standard

FT 30 Series: Tee Strainer Dimensions | 2" - 30" | ANSI CLASS 300

DIMENSIONS AND WEIGHTS ⁽¹⁾

	in	2	2 1/2	3	4	5	6	8	10	12	14	16	18	20	24	30
	mm	50	65	80	100	125	150	200	250	300	355	405	460	508	610	762
(A₁) Face to Face ⁽²⁾ FT 30, FT 33 - Butt-Weld	in	5.00	6.00	6.75	8.25	9.75	11.25	14.00	17.00	20.00	22.00	24.00	27.00	30.00	34.00	C/F
	mm	127	152	172	210	248	286	356	432	508	559	610	686	762	864	C/F
(A₂) Face to Face ⁽²⁾ FT 31, FT 34 - Flanged	in	10.75	12.25	13.25	15.25	17.75	19.25	23.00	26.50	30.50	33.50	35.75	39.75	43.00	47.50	C/F
	mm	273	311	337	387	451	489	584	673	775	851	908	1010	1092	1207	C/F
(B₁) Ctr-Line to Top ⁽³⁾ FT 30-32 - Bolted Cover	in	5.38	6.13	6.63	7.63	8.88	9.63	11.50	13.25	15.25	16.75	17.88	19.88	21.5	23.75	C/F
	mm	137	157	168	194	225	245	292	337	387	426	454	505	546	603	C/F
(B₂) Ctr-Line to Top ⁽³⁾ FT 33-35 - Quick Open Cover	in	n/a	n/a	n/a	n/a	n/a	9.94	11.56	13.94	15.90	17.60	19.00	21.50	23.94	27.25	C/F
	mm	n/a	n/a	n/a	n/a	n/a	252	294	354	403	446	483	546	608	692	C/F
C Dimension Screen Removal	in	11.94	13.69	15.00	17.50	20.53	22.56	27.31	31.90	36.88	40.50	43.75	48.75	53.00	59.50	C/F
	mm	303	348	381	446	522	573	694	810	937	1029	1111	1238	1346	1511	C/F
Approx. Weight: FT 30	lb	25.63	C/F	51.25	83.13	C/F	161.25	255.00	381.25	578.75	776.25	1056.25	1332.50	1743.75	3296.25	C/F
	kg	11.63	C/F	23.25	37.71	C/F	73.14	115.70	173.00	262.52	352.00	479.11	604.42	791.00	1495.20	C/F
Approx. Weight: FT 31	lb	48.13	C/F	96.25	149.38	C/F	273.75	427.50	631.25	933.75	1291.25	1681.25	2132.50	2743.75	4746.25	C/F
	kg	21.80	C/F	43.70	67.80	C/F	124.20	194.00	286.33	423.54	585.70	762.60	967.30	1244.54	2153.00	C/F

1. Dimensions and weights of the FT 30 Series are provided for reference only. Certified drawings are required for all Titan Fabrications.
2. Face to face values have a tolerance of ±0.06 in (±2.0 mm) for sizes 10" and lower and a tolerance of ±0.12 in (±3.0 mm) for sizes 12" and larger.
3. Center line to top dimension is to the top of the body flange. Quick open cover dimension is to the top of body housing.

Titan FCI's fabricated products are made to each customer's unique specifications. Dimensions, materials, and all other product details referenced in this literature are general in nature. Some options may not be available in all sizes and/or models. Titan FCI reserves the right to make design and specification changes to improve the products without prior notification.

For exact product specifications, please consult the Titan FCI factory and request certified engineering documents.

FABRICATED TEE STRAINERS

2" - 30" | ANSI CLASS 600

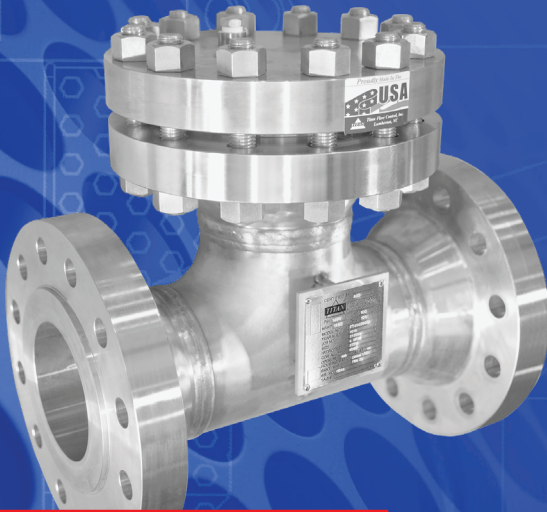

6" Fabricated Tee Strainer, ANSI 600, with Bolted Cover Assembly Shown

Fabricated Tee Strainers are required when an off-the-shelf solution will not meet your exact piping requirements. All of our Fabricated Strainers are made right here in the USA, at our state-of-the-art facility in the southeastern part of North Carolina.

CUSTOM COVER SOLUTIONS INCLUDING DAVITS & HINGED COVER

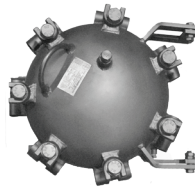

HINGED

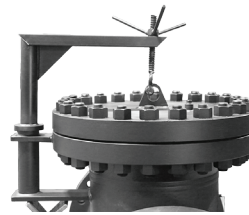

DAVIT



BOLTED

MODEL

FT 40 Series - 600 Class

MATERIALS:

- Carbon Steel • Stainless Steel
- Other Alloys

OPTIONS



- Gauge Taps
- Vent - (Standard)
- Drains
- Back Flush Valves
- Semi-Automatic
- Pressure Gauges
- DP Gauge Switch



ANSI CLASSES

ANSI Class 150 up to high pressure 900 class



STRAINING ELEMENTS

Customize to fit your requirements
Heavy Duty Baskets



END CONNECTIONS

Flanged, Raised Face, RTJ, Butt Weld, Socket Weld, Threaded



SANITARY

Sanitary Application Designs for food/pharmaceutical processing



TEMPERATURE CONTROL

Steam Jacket casing for set temperature control



UNIQUE PROJECTS

Rotated and Offset Nozzles to fit into your applications



290 Corporate Dr
www.titanfci.com
Phone: 910.735.0000

Lumberton, NC 28358
titan@titanfci.com
Fax: 910.738.3848

2" - 30"

FT 40 Series
Tee Strainer

ANSI Class
600

BILL OF MATERIALS⁽¹⁾
FT 40 Series

Part	FT 40-45 CS	FT 40-45 SS
1 Body	Carbon Steel A234 Gr.WPB	Stainless Steel SA403
2 Cover	Carbon Steel A105	Stainless Steel SA182 Type 316
3 Cover Gasket/ O-Ring ⁽²⁾	Bolted: Spiral Wound Stainless Steel	Quick Open: Buna-N ⁽³⁾
4 Straining Element ⁽²⁾⁽⁴⁾⁽⁵⁾	T304 SS	T304 SS
5 Inlet/Outlet Flange	Carbon Steel A105	Stainless Steel SA182 Type 316
6 Weld Neck Flange	Carbon Steel A105	Stainless Steel SA182 Type 316
7 Bolts	Carbon Steel A193-B7	Stainless Steel A193 B8 M
8 Nuts	Carbon Steel A194 2H	Stainless Steel A194 Gr.8
9 Vent with Plug ⁽⁶⁾	Carbon Steel A105	Stainless Steel SA182 Type 316

1. Bill of Materials represents standard materials. Equivalent or better materials may be substituted at the manufacturer's discretion.
2. Titan recommends keeping spare parts on hand.
3. Buna-N is standard for applications below 250° F. Viton is standard for applications above 250° F.
4. Max mesh size available is 60 mesh.
5. 1/8" perf is standard for all mesh lined straining elements.
6. 1/2" NPT is standard

Tee Strainers are not recommended for suction applications.

Optional bottom drains (2" NPT Standard) are available at extra cost.

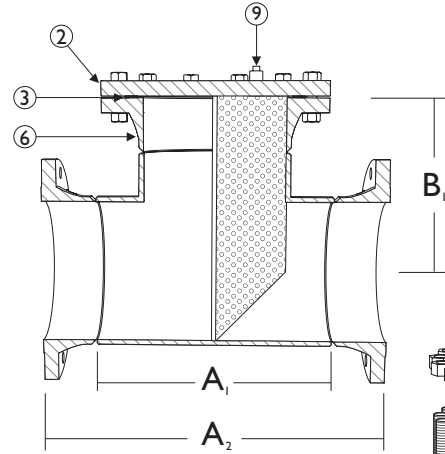

Model FT 41

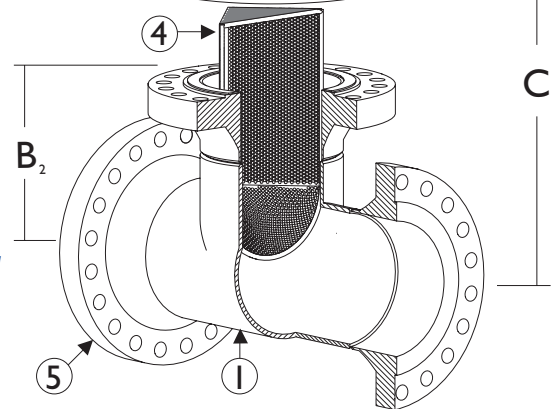
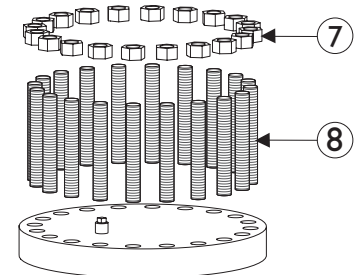

Model FT 41

Illustrations are representative of Titan FCI fabricated tee strainers; however, as with all fabricated designs, actual products may vary. Certified drawings are required for all Titan Fabrications.

FT 40 Series: Tee Strainer Dimensions | 2" - 30" | ANSI CLASS 600

DIMENSIONS AND WEIGHTS⁽¹⁾

	in	2	2 1/2	3	4	5	6	8	10	12	14	16	18	20	24	30
(A₁) Face to Face ⁽²⁾ FT 40, FT 43 - Butt-Weld	mm	50	65	80	100	125	150	200	250	300	355	405	460	508	610	762
	in	5.00	6.00	6.75	8.25	9.75	11.25	14.00	17.00	20.00	22.00	24.00	27.00	30.00	34.00	C/F
(A₂) Face to Face ⁽²⁾ FT 41, FT 44 - Flanged	mm	127	152	172	210	248	286	356	432	508	559	610	686	762	864	C/F
	in	11.50	13.00	14.00	17.00	19.50	21.25	25.25	29.75	33.00	35.75	38.75	42.25	45.75	50.75	C/F
(B₁) Ctr-Line to Top ⁽³⁾ FT 40-42 - Bolted Cover	mm	146	165	178	216	248	270	321	378	419	454	492	537	581	645	C/F
	in	5.75	6.50	7.00	8.50	9.75	10.63	12.63	14.90	16.50	17.88	19.38	21.13	22.88	25.38	C/F
C Dimension Screen Removal	mm	322	367	400	489	566	624	751	892	1000	1086	1188	1302	1416	1594	C/F
	in	12.70	14.44	15.75	19.25	22.28	24.57	29.57	35.13	39.38	42.75	46.75	51.25	55.75	62.75	C/F
Approx. Weight: FT 40	lb	31.88	C/F	62.50	118.75	C/F	288.75	418.75	727.50	957.50	1367.50	1945.00	2412.50	3207.50	4875.00	C/F
	kg	14.50	C/F	28.35	53.86	C/F	131.00	190.00	330.00	434.32	620.30	882.24	1094.30	1454.90	2211.30	C/F
Approx. Weight: FT 41	lb	61.88	C/F	120.00	223.75	C/F	491.25	718.75	1202.50	1522.50	2235.00	3147.50	3800.00	4932.50	7317.50	C/F
	kg	28.10	C/F	54.43	101.50	C/F	222.82	326.02	545.50	690.60	1013.80	1427.70	1723.70	2237.34	3319.20	C/F

1. Dimensions and weights of the FT 40 Series are provided for reference only. Certified drawings are required for all Titan Fabrications.
2. Face to face values have a tolerance of ±0.06 in (±2.0 mm) for sizes 10" and lower and a tolerance of ±0.12 in (±3.0 mm) for sizes 12" and larger.
3. Center line to top dimension is to the top of the body flange. Quick open cover dimension is to the top of body housing.

TEMPORARY STRAINERS

Temporary Strainers are fabricated in the Titan FCI factory, so they can be made to meet your unique specifications! Listed are standard models and dimensions. Contact factory for more information.

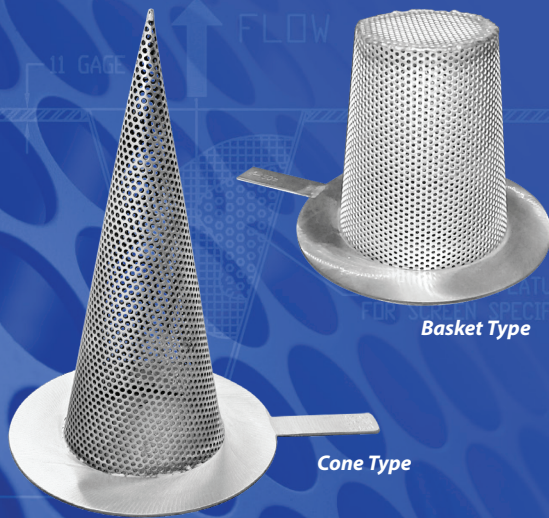

Cone Type

Model	Class
PS 15	150/300
PS 15	600
PS 15	900
PS 15	1500

Basket Type

Model	Class
PS 16	150/300
PS 16	600
PS 16	900
PS 16	1500

Uses

Temporary Cone and Basket Strainers are used for start up of new or revamped piping systems. They are designed to provide inexpensive protection for costly valves, pumps, meters, and other mechanical equipment.

Materials

Standard temporary strainer materials are stainless steel and carbon steel; however, other materials are also available. Contact factory. Diameter holes of 1/8" on 3/16" centers is the standard perforation, but most sizes/varieties are available. For mesh lined strainers, flow direction must be specified.

Open Area

The available range in open area of strainer to cross section of pipe is 100% to 300%.

Flanges

Titan can manufacture flanges to accommodate raised face or ring joint flanges.

Handles

Temporary Baskets and Cone Strainers have handles. Handles are generally 1" wide x 3" long.

DIMENSIONAL & TECHNICAL DATA

Nominal Pipe Size ⁽²⁾	ØA (OD)						C ⁽³⁾ Gauge Thickness	H (Cone Type, Height) ⁽⁴⁾ with 1/8" Perf. On 3/16" Centers				H (Basket Type, Height) ⁽⁴⁾ with 1/8" Perf on 3/16" Centers				Bottom Diameter
	ANSI 150	ANSI 300	ANSI 600	ANSI 900	ANSI 1500	ØB (ID)		L=100%	L=150%	L=200%	L=300%	L=100%	L=150%	L=200%	L=300%	
3/4	2.13	C/F	2.5	2.63	2.63	0.63	11	C/F	C/F	C/F	C/F	C/F	C/F	C/F	C/F	0.38
1	2.5	C/F	2.75	3	3	0.75	11	C/F	C/F	C/F	C/F	C/F	C/F	C/F	C/F	0.5
1 1/2	3.25	3.63	3.63	3.75	3.75	1.25	11	3.5	4.5	6	9	2	2.5	3.5	5	0.75
2	4	4.25	4.25	5.5	5.5	1.75	11	4	6	8	11	2.5	3	4	6	1
2 1/2	4.75	5	5	6.38	6.38	2.25	11	4	6	8	11	2.5	3	4.5	6	1.25
3	5.25	5.75	5.75	6.5	6.75	2.75	11	5	7	9	13	3	4.5	6	8	1.5
4	6.75	7	7.5	8	8.13	3.75	11	8	10	12	18	4	5	7	11	2
5	7.63	8.38	9.38	9.63	9.88	4.63	11	8	11	14	22	4.5	7	9	14	2.5
6	8.63	9.75	10.38	11.25	11	5.38	11	9	13	18	25	5.5	8	11	17	3
8	10.88	12	12.5	14	13.75	7.38	11	12	17	23	33	7	11	14	21	4
10	13.25	14.13	15.63	17	17	9.38	11	14	21	28	41	8	13	17	26	5
12	16	16.5	17.88	19.5	20.38	11	11	16	25	34	49	10	15	20	31	6
14	17.38	19	19	20.38	22.63	12.25	11	18	27	36	53	10	16	22	33	7
16	20.13	21.13	21.88	22.5	C/F	14	11	21	31	40	61	12	19	24	37	8
18	21.25	23.38	23.75	25	C/F	15.75	11	24	35	46	68	14	21	27	41	9
20	23.5	25.63	26.63	C/F	C/F	17.5	11	26	38	51	76	16	24	31	48	10
24	27.88	30.38	30.88	C/F	C/F	21.25	11	31	45	61	90	18	28	37	57	12

1. Dimensions for Titan's PS 15 and PS 16 are provided for reference only. When required, request certified drawings. All dimensions, except thickness are given in inches.
2. Larger sizes are available; please contact factory.
3. Gauge thickness is for flange thickness only. The standard gauge of strainer material ranges between 11 to 22, depending on hole size.
4. Dimension H, height of strainer, is dependant upon the open area of the strainer as defined in the table by L, L, or the percentage of open area in the strainer relative to the cross section of pipe, is available in a range of 100% to 300% (based on the perforated screens).

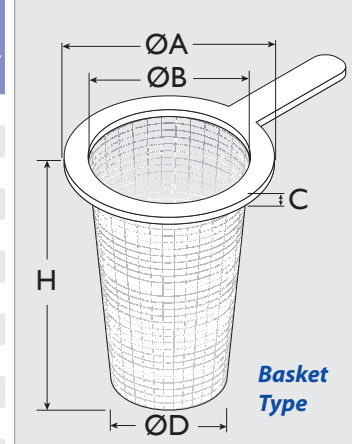
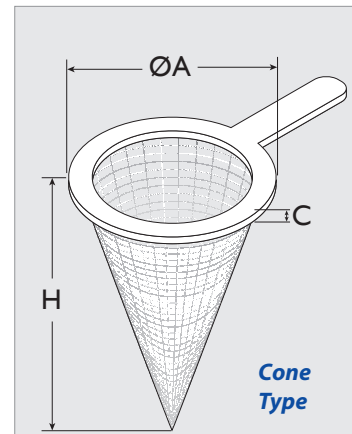

Illustrations represent Titan FCI's Temporary Cone Strainer and Temporary Basket Strainer. Titan FCI's fabricated products are made to each customer's unique specifications. Dimensions, materials, illustrations, and all other product details referenced in this literature are general in nature. Some options may not be available in all sizes and/or models. Titan FCI reserves the right to make design and specification changes to improve the products without prior notification. **For exact product specifications, please consult the Titan FCI factory and request certified engineering documents.**

TEMPORARY PLATE STRAINERS

Temporary Strainers are fabricated in the Titan FCI factory so they can be made to meet your unique specifications! Listed are standard models and dimensions. Contact factory for more information.

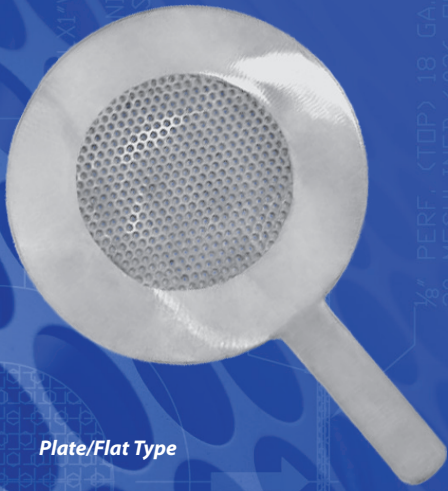

Plate/Flat Type

Model	Material	Class	Model	Material	Class
PS 17	CS or SS	150/300	PS 17	CS or SS	900
PS 17	CS or SS	600	PS 17	CS or SS	1500

Specify When Ordering:

- Pipe Size • Perforation or Mesh Size • Pressure Rating • Material

Uses

Temporary Cone and Basket Strainers are used for start up of new or revamped piping systems. They are designed to provide inexpensive protection for costly valves, pumps, meters, and other mechanical equipment.

Materials

Standard temporary strainer materials are stainless steel and carbon steel; however, other materials are also available. Contact factory.

Perforation/Mesh

Diameter holes of 1/8" on 3/16" centers is the standard perforation, but most sizes/varieties are available. For mesh lined strainers, flow direction must be specified.

Flanges

Titan can manufacture flanges to accommodate raised face or ring joint flanges.

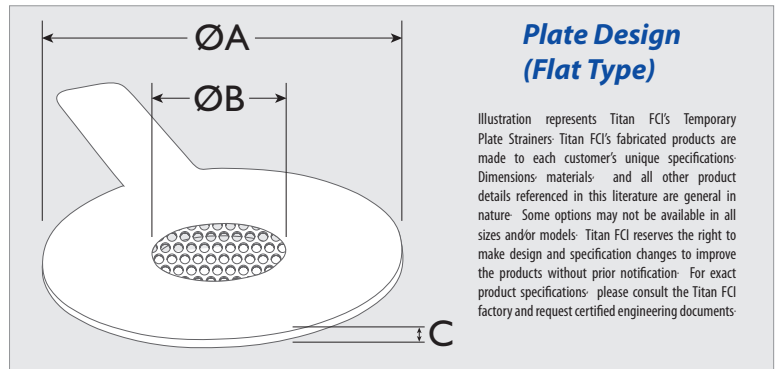

DIMENSIONAL & TECHNICAL DATA

Nominal Pipe Size ⁽²⁾	ØA (OD)					ØB (ID)	C ⁽³⁾ Gauge Thickness
	ANSI 150	ANSI 300	ANSI 600	ANSI 900	ANSI 1500		
3/4	2.13	C/F	2.5	2.63	2.63	0.63	11
1	2.5	C/F	2.75	3	3	0.75	11
1 1/2	3.25	3.63	3.63	3.75	3.75	1.25	11
2	4	4.25	4.25	5.5	5.5	1.75	11
2 1/2	4.75	5	5	6.38	6.38	2.25	11
3	5.25	5.75	5.75	6.5	6.75	2.75	11
4	6.75	7	7.5	8	8.13	3.75	11
5	7.63	8.38	9.38	9.63	9.88	4.63	11
6	8.63	9.75	10.38	11.25	11	5.38	11
8	10.88	12	12.5	14	13.75	7.38	11
10	13.25	14.13	15.63	17	17	9.38	11
12	16	16.5	17.88	19.5	20.38	11	11
14	17.38	19	19	20.38	22.63	12.25	11
16	20.13	21.13	21.88	22.5	C/F	14	11
18	21.25	23.38	23.75	25	C/F	15.75	11
20	23.5	25.63	26.63	C/F	C/F	17.5	11
24	27.88	30.38	30.88	C/F	C/F	21.25	11

1. Dimensions for Titan's PS 17 are provided for reference only. Certified drawings are required for all Titan Fabrications. OD and ID dimensions are in inches. 3. Gauge thickness is for flange thickness only. The standard gauge of strainer material ranges between 11 to 22, depending on hole size. 2. Larger sizes are available; please contact factory.

Titan FCI's fabricated products are made to each customer's unique specifications. Dimensions, materials, and all other product details referenced in this literature are general in nature. Some options may not be available in all sizes and/or models. Titan FCI reserves the right to make design and specification changes to improve the products without prior notification. For exact product specifications, please consult the Titan FCI factory and request certified engineering documents.

SPECTACLE BLINDS | CLOSED BLINDS OPEN BLINDS (RING SPACER)

*When Total System Isolation is required -
Titan Blinds provide Complete, Positive Shutoff.*

Vapor Blinds, Test Blinds and Bleed Rings are also available.
Contact Us for more information.

Spectacle Blind PB18



Single Blind PB19



Ring Spacer PB 20



Models

Name	Description
PB 18	Spectacle Blind
PB 19	Single Blind
PB 20	Ring Spacer

Materials

Stainless Steel
Carbon Steel

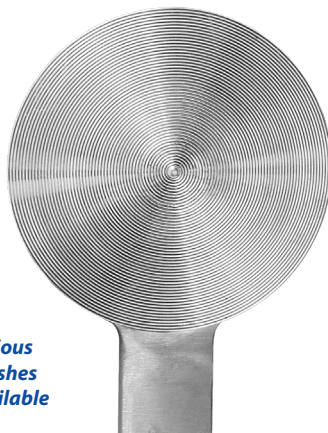

Various
Finishes
Available

Benefits of Titan Blinds

- Provides Permanent - Positive Shutoff
- Promotes Safety during downstream Service Operations
- Spectacle Blinds provide Visible Shutoff
- Economical Solution when compared to Isolation Valves
- Quick - One Man Operation
- Long Service Life
- Can be used with liquids, solids, slurries, and gases

Body Materials

Standard materials are stainless steel and carbon steel. Contact factory for additional materials. Special Coatings are also available for highly corrosive applications.

Seat Materials

A variety of O-Ring Seats are available including Viton, Buna-N, and Teflon. Contact factory for more information.

End Connections

Available with raised or flat-faced blinds. Ring type joints are also available.

Finishes

Available with serrated (phonographic style) surface or ground finished. Surface dimension in Micro-inch ASA 500, 250, 125, 63, or 32 should be specified; standard is a smooth finish.

Standards

Titan FCI's Spectacle Blinds, Single Blinds, and Ring Spacers are designed in accordance with ASME B16.48 - Line Blanks.

Note: Pipeline Blinds are not the same as bolted on, Blind Flanges.

Illustrations represent Titan FCI's fabricated PB 18, PB 19, & PB 20. Titan's fabricated products are made to each customer's unique specifications. Dimensions, materials, illustrations, and all other product details referenced in this literature are general in nature. Some options may not be available in all sizes and/or models. Titan FCI reserves the right to make design and specification changes to improve the products without prior notification. *For exact product specifications, please consult the Titan FCI factory and request certified engineering documents.*



290 Corporate Dr
www.titanfci.com
Phone: 910.735.0000

Lumberton, NC 28358
titan@titanfci.com
Fax: 910.738.3848

Spectacle Blinds and Single Blinds

PB 18 | PB 19 | PB 20

ANSI CLASS 150 BLINDS						
Nominal Pipe Size ⁽²⁾	ØA (ID)	ØB (OD)	C (Ctr. to Ctr.)	ØD (Pivot Hole)	E (Web Width)	F (Thickness)
1/2	0.62	1.75	2.38	0.62	1.5	0.12
3/4	0.82	2.12	2.75	0.62	1.5	0.12
1	1.05	2.5	3.12	0.62	1.5	0.12
1 1/4	1.66	2.88	3.5	0.62	1.5	0.25
1 1/2	1.9	3.25	3.88	0.62	1.5	0.25
2	2.38	4	4.75	0.75	2	0.25
2 1/2	2.88	4.75	5.5	0.75	2	0.25
3	3.5	5.25	6	0.75	2.5	0.25
3 1/2	4	6.25	7	0.75	2.5	0.38
4	4.5	6.75	7.5	0.75	2.5	0.38
5	5.56	7.62	8.5	0.88	3	0.38
6	6.62	8.62	9.5	0.88	3	0.5
8	8.62	10.88	11.75	0.88	3	0.5
10	10.75	13.25	14.25	1	4	0.62
12	12.75	16	17	1	4	0.75
14	14	17.62	18.75	1.12	4.25	0.75
16	16	20.12	21.25	1.12	4.25	0.88
18	18	21.5	22.75	1.25	4.5	1
20	20	23.75	25	1.25	4.75	1.12
24	24	28.12	29.5	1.38	5.5	1.12

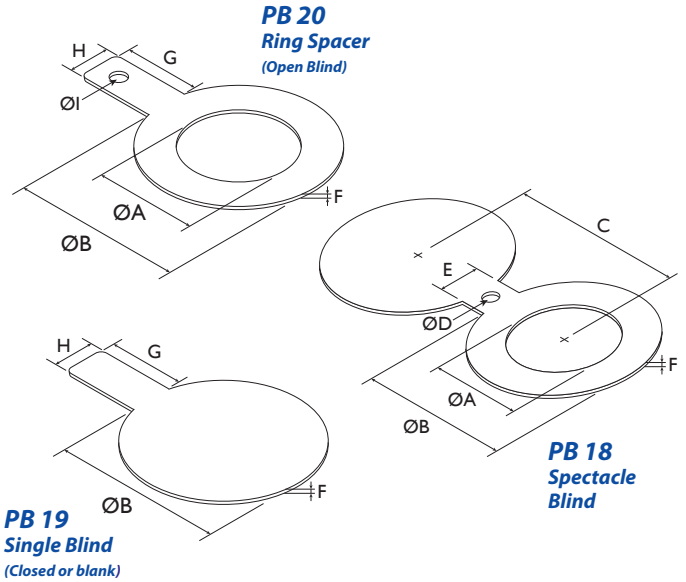

Handle Dimensions (All Classes)			
Size Ranges	G (Length)	H (Width)	ØI (Hole)
½" - 3"	4	1	0.5
3½" - 10"	5	1	0.5
12"	5	1.5	0.75
14" - 24"	6	1.5	0.75

Illustrations represent Titan FCI's fabricated PB 18, PB 19, & PB 20. Titan's fabricated products are made to each customer's unique specifications. Dimensions, materials, illustrations, and all other product details referenced in this literature are general in nature. Some options may not be available in all sizes and/or models. Titan FCI reserves the right to make design and specification changes to improve the products without prior notification. **For exact product specifications, please consult the Titan FCI factory and request certified engineering documents.**

ANSI CLASS 300 BLINDS						
Nominal Pipe Size ⁽²⁾	ØA (ID)	ØB (OD)	C (Ctr. to Ctr.)	ØD (Pivot Hole)	E (Web Width)	F (Thickness)
1/2	0.62	2	2.62	0.62	1.5	0.25
3/4	0.82	2.5	3.25	0.75	1.5	0.25
1	1.05	2.75	3.5	0.75	1.5	0.25
1 1/4	1.66	3.12	3.88	0.75	1.5	0.25
1 1/2	1.9	3.62	4.5	0.88	2	0.25
2	2.38	4.25	5	0.75	2	0.38
2 1/2	2.88	5	5.88	0.88	2.5	0.38
3	3.5	5.75	6.62	0.88	2.5	0.38
3 1/2	4	6.38	7.25	0.88	2.5	0.5
4	4.5	7	7.88	0.88	2.5	0.5
5	5.56	8.38	9.25	0.88	3	0.62
6	6.62	9.75	10.62	0.88	3	0.62
8	8.62	12	13	1	3	0.88
10	10.75	14.12	15.25	1.12	4	1
12	12.75	16.5	17.75	1.25	4	1.12
14	14	19	20.25	1.25	4.25	1.25
16	16	21.12	22.5	1.38	4.25	1.5
18	18	23.38	24.75	1.38	4.5	1.62
20	20	25.62	27	1.38	4.75	1.75
24	24	30.38	32	1.62	5.5	2

ANSI CLASS 600 BLINDS						
Nominal Pipe Size ⁽²⁾	ØA (ID)	ØB (OD)	C (Ctr. to Ctr.)	ØD (Pivot Hole)	E (Web Width)	F (Thickness)
1/2	0.62	2	2.62	0.62	1.5	0.25
3/4	0.82	2.5	3.25	0.75	1.62	0.25
1	1.05	2.75	3.5	0.75	2.25	0.25
1 1/4	1.44	3.12	3.87	0.75	2	0.38
1 1/2	1.68	3.62	4.5	0.88	2.62	0.38
2	2.16	4.25	5	0.75	2.25	0.38
2 1/2	2.64	5	5.87	0.88	2.62	0.5
3	3.26	5.75	6.62	0.88	2.62	0.5
3 1/2	3.76	6.25	7.25	1	3	0.62
4	4.26	7.5	8.5	1	3	0.62
5	5.3	9.38	10.5	1.12	3.37	0.75
6	6.36	10.38	11.5	1.12	3.37	0.88
8	8.33	12.5	13.75	1.25	3.75	1.12
10	10.42	15.62	17	1.37	4.12	1.38
12	12.39	17.88	19.25	1.37	4.12	1.62
14	13.62	19.25	20.75	1.5	4.5	1.75
16	15.62	22.12	23.75	1.62	4.87	2
18	17.62	24	25.75	1.75	5.25	2.12
20	19.56	26.75	28.5	1.75	5.25	2.5
24	23.5	31	33	2	6	2.88

Titan FCI's fabricated products are made to each customer's unique specifications. Dimensions, materials, and all other product details referenced in this literature are general in nature. Some options may not be available in all sizes and/or models. Titan FCI reserves the right to make design and specification changes to improve the products without prior notification. **For exact product specifications, please consult the Titan FCI factory and request certified engineering documents.**

RESTRICTION ORIFICE PLATES

Standard Bore



A Restriction Orifice Plate is a device used to restrict flow. It reduces flow and pressure from the upstream side to the downstream side. This is beneficial in order to reduce noise and protect downstream equipment.

Flow Measuring Orifice Plates are also available.

Please contact Titan directly for more information regarding Flow Measuring Orifice Plates.

Multi-Hole Bore

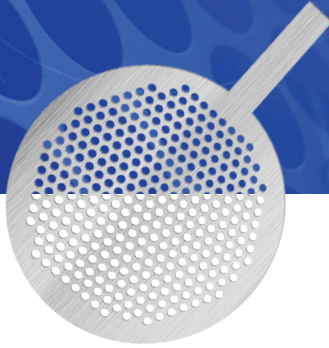

Model	Material
PB 21 CS	Carbon Steel
PB 22 SS	Stainless Steel

Materials

Standard materials for orifice plates are stainless steel and carbon steel. Contact factory for additional materials such as ceramic, fiberglass reinforced plastic, duplex stainless steel, etc.

Bore Diameter

Sizing of the restriction orifice is specified by the customer in order to meet specific application requirements. For reference, see below for common design options.

Codes & Standards

Currently, there are no corresponding codes or standards that address Restriction Orifice Plates.

Handles

Orifice plates can be ordered with or without a handle. Handles are generally 1" wide by 3 3/4" long.

Additional Design Options

Restriction Orifice plates can have a variety of specifications. Bores can be placed concentrically or eccentrically with the pipe and can have a full or segmented opening.

Eccentric Bore



Multi-Stage Restriction Plate Assembly

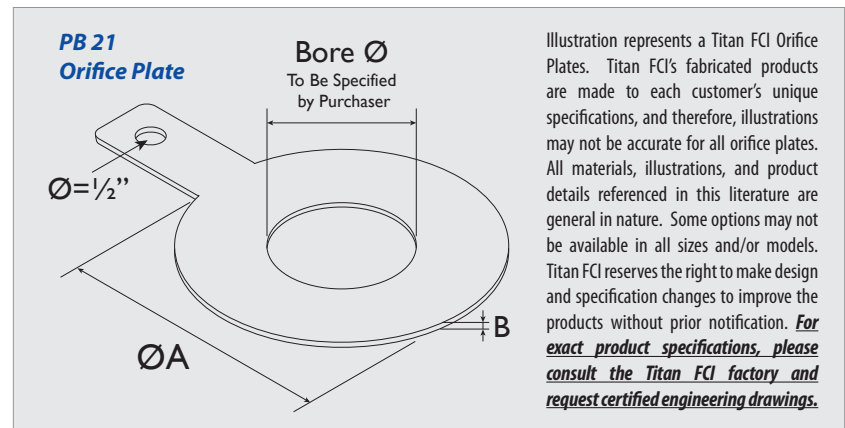
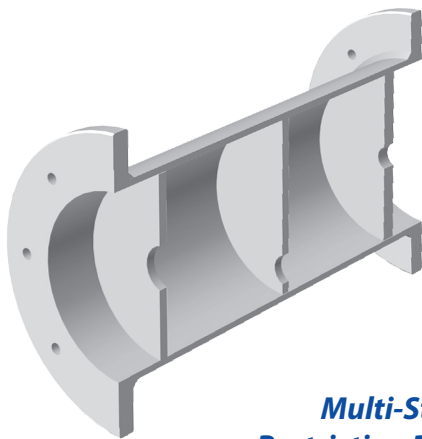

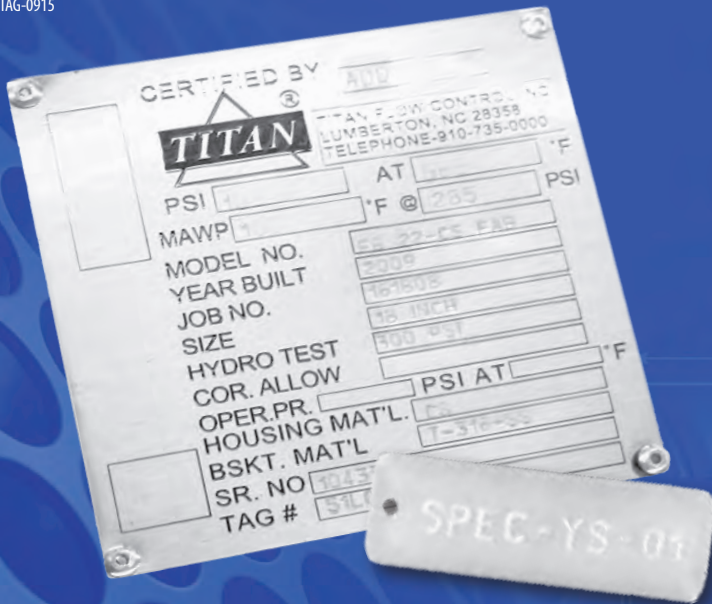

IDENTIFICATION TAGS

Contact **Titan Flow Control, Inc.** for any of your identification needs. Two sizes of Standard Stainless Steel Tags (as illustrated below) are available for easy ordering, but Titan can make tags in a variety of sizes and specifications.

Titan Flow Control, Inc. has the capability to create identification tags for all your marking and labeling needs.

Make An Impression

High quality tags look professional. They are available in a wide variety of sizes, shapes, and materials. Titan FCI can even add your company's logo and information! (Graphic design charges may apply.)

Conveniently Identify Products

Tags can be marked with product numbers, dates, batch numbers, logos, etc and then attached to the product before its shipped to you for easy identification

Simplify and Organize

Titan can mark small parts, tools, keys, and more so you can stay organized.

**Great for Identifying
Check Valves and
other products**

**Organize and Track
Small Items or Parts**

**Leave a Lasting,
Professional
Impression**



Standard Stainless Steel Tags

Two Standard Sizes Available:

2" x 3/4" (50 mm x 20 mm)

3" x 1" (80 mm x 25 mm)

Other sizes and shapes are available. Contact factory.

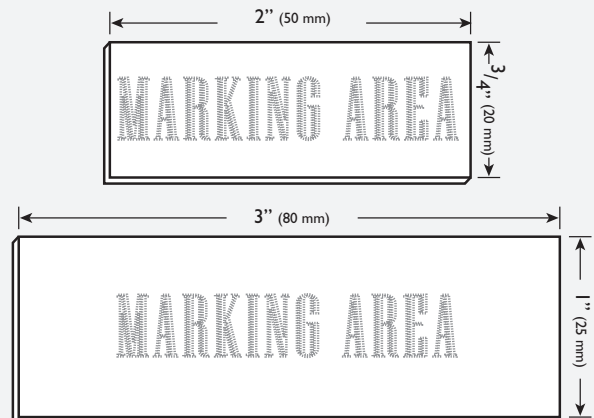

Specifications

Maximum marking area:
4" x 4" (100 x 100 mm)
Tag height/thickness range:
0.02" To 12" (0.5 To 300 mm)
Character range:
0.04" To 3.15"
(0.5 To 80 mm at intervals
of 0.1 mm)

Capabilities

Markings on various materials
(Treated and untreated metal, plastic, wood, and more)
Numerous shapes and sizes of tags
Logo design (Graphic design fees may apply)
Dates, times, and batch numbering capabilities
Linear, angular, and circular markings
Special markings such as reversed, mirrored, and reflected

Titan FCI makes every effort to ensure the information presented on our literature accurately reflects exact product specifications. However, as product changes occur, there may be short-term differences between actual product specifications and the information contained within our literature. Titan FCI reserves the right to make design and specification changes to improve our products without prior notification. Some options may not be available on all types of identification tags. **For exact product specifications, please consult the Titan FCI factory.**

Titan FCI's fabricated products are made to each customer's unique specifications. Dimensions, materials, and all other product details referenced in this literature are general in nature. Some options may not be available in all sizes and/or models. Titan FCI reserves the right to make design and specification changes to improve the products without prior notification.

For exact product specifications, please consult the Titan FCI factory and request certified engineering documents.

DESIGN CAPABILITIES

Piping Systems often have special requirements that can't be accomplished with off-the-shelf products. To address this problem, Titan can design and fabricate pressure vessels based upon your detailed application requirements. Our knowledgeable engineers are always available to discuss your special application requirements.

Experience Your Designs with Interactive 3D Models



Using powerful 3D Modeling Tools, Titan Flow Control can quickly transform your design requirements into great products. These rapid development tools allow Titan to provide you with an accurate 3D Model before fabrication starts. This allows the end user to virtually review the design within their system; ensuring proper fit and avoiding costly mistakes.

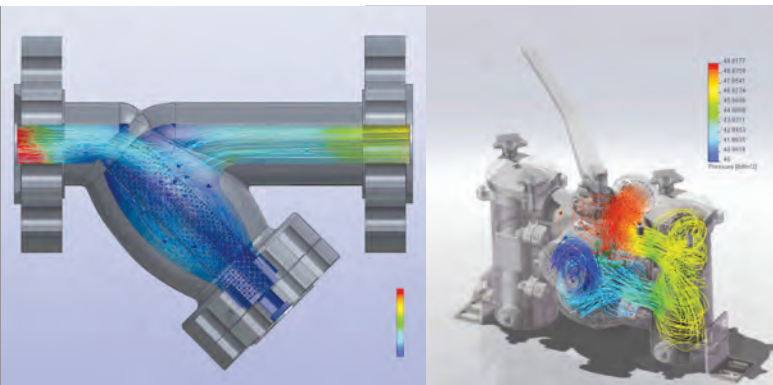
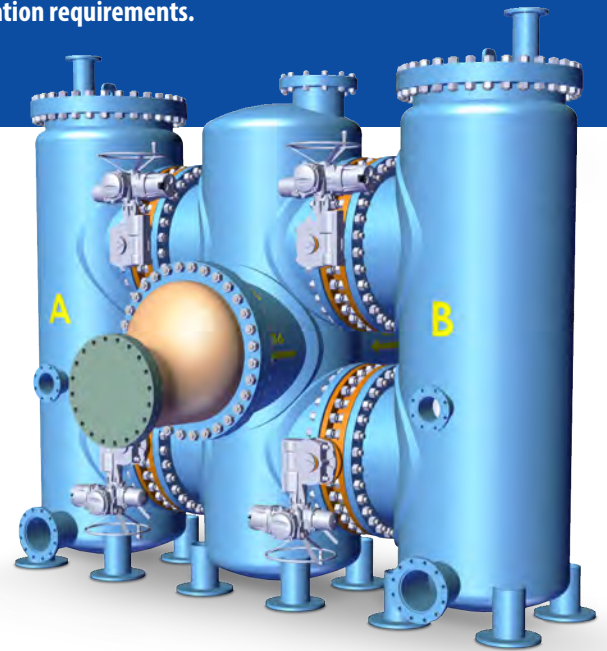

Flow Analysis

Pumping Systems demand that energy requirements be exact. Placing an unknown element into a system that results in excessive head loss can be disastrous. Titan uses advanced CFD (computational fluid dynamics) analysis, to make sure your design performs as expected. Our CFD tools can assist in aligning your design with flow conditions (such as pressure drop) to satisfy stated design goals.

Titan Is Up To Code

Pressure Vessels must strictly adhere to ASME specifications. To ensure your design is precise, Titan utilizes a specialized modeling software to ensure nothing is left to chance. This productivity tool automatically calculates the appropriate sizes, thicknesses and ratings to meet Code Requirements. This eliminates the error-prone, time-consuming manual process commonly employed.

"If you don't have time to do it right, you must have time to do it over"

- John Wooden

Designing and fabricating pressure vessels is serious business. Titan's veteran engineers can help you get it right the first time.

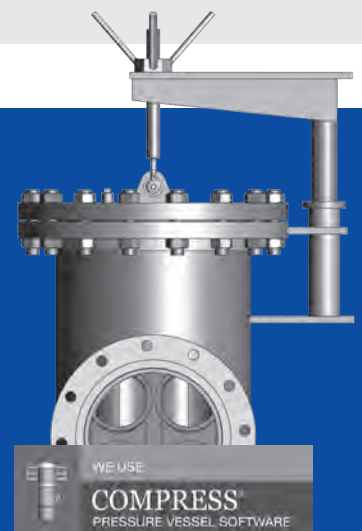

Call us for more information and let's get started on your design today! ▶▶▶  910.735.0000

MODEL IDENTIFICATION NUMBERING SYSTEM - BY ANSI CLASS

ANSI CLASS 150

Fabricated Basket Strainer	Fabricated Duplex Strainer (Inline)	Fabricated Duplex Strainer (Offset)	Fabricated Tee Strainer	Configuration		
Series	Series	Series	Series	Ends	Class	Cover
FB20	FDI20	FDO20	FT20	Butt-weld	150	Bolted
FB21	FDI21	FDO21	FT21	Flanged	150	Bolted
FB22	FDI22	FDO22	FT22	RTJ	150	Bolted
FB23	FDI23	FDO23	FT23	Butt-weld	150	Quick
FB24	FDI24	FDO24	FT24	Flanged	150	Quick
FB25	FDI25	FDO25	FT25	RTJ	150	Quick

ANSI CLASS 300

Fabricated Basket Strainer	Fabricated Duplex Strainer (Inline)	Fabricated Duplex Strainer (Offset)	Fabricated TEE Strainer	Configuration		
Series	Series	Series	Series	Ends	Class	Cover
FB30	FDI30	FDO30	FT30	Butt-weld	300	Bolted
FB31	FDI31	FDO31	FT31	Flanged	300	Bolted
FB32	FDI32	FDO32	FT32	RTJ	300	Bolted
FB33	FDI33	FDO33	FT33	Butt-weld	300	Quick
FB34	FDI34	FDO34	FT34	Flanged	300	Quick
FB35	FDI35	FDO35	FT35	RTJ	300	Quick

ANSI CLASS 600

Fabricated Basket Strainer	Fabricated Duplex Strainer (Inline)	Fabricated Duplex Strainer (Offset)	Fabricated TEE Strainer	Configuration		
Series	Series	Series	Series	Ends	Class	Cover
FB40	FDI40	FDO40	FT40	Butt-weld	600	Bolted
FB41	FDI41	FDO41	FT41	Flanged	600	Bolted
FB42	FDI42	FDO42	FT42	RTJ	600	Bolted
FB43	FDI43	FDO43	FT43	Butt-weld	600	Quick
FB44	FDI44	FDO44	FT44	Flanged	600	Quick
FB45	FDI45	FDO45	FT45	RTJ	600	Quick

ANSI CLASS 900

Fabricated Basket Strainer	Fabricated Duplex Strainer (Inline)	Fabricated Duplex Strainer (Offset)	Fabricated TEE Strainer	Configuration		
Series	Series	Series	Series	Ends	Class	Cover
FB50	FDI50	FDO50	FT50	Butt-weld	900	Bolted
FB51	FDI51	FDO51	FT51	Flanged	900	Bolted
FB52	FDI52	FDO52	FT52	RTJ	900	Bolted
FB53	FDI53	FDO53	FT53	Butt-weld	900	Quick
FB54	FDI54	FDO54	FT54	Flanged	900	Quick
FB55	FDI55	FDO55	FT55	RTJ	900	Quick



290 Corporate Drive • Lumberton, NC 28358
Tel: 910.735.0000 • Fax: 910.738.3848 • titan@titanfci.com

www.titanfci.com



Titan Flow Control, Inc.
Your pipeline to the future!

Series BF 75
Wafer Style > Cast Iron

Series BF 76
Lug Style > Ductile Iron

Designed in accordance with:
MSS-SP-67 & API 609

Size Range: 2" ~ 48"

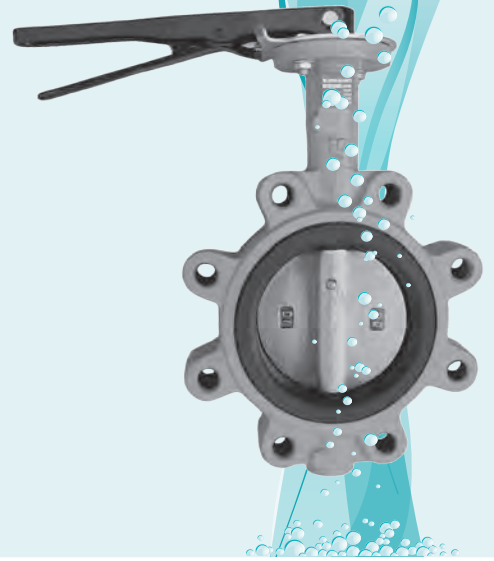

Resilient Seated Butterfly Valves Wafer Type Cast Iron > Lug Type Ductile Iron

Design Features

> **Universal Mounting Flange**

The cast-in actuator flange is universally designed in accordance with ISO 5211 standard dimensions. The mounting flange can accommodate all types of operators such as: 10-position handle kits, gear operators, electric actuators, and pneumatic actuators. For actuators, Titan FCI may provide both direct mount and bracket mount designs. Please contact Titan FCI about your specific automation requirements.

> **Extended Neck**

The extended neck provides clearance for 2" of piping insulation. Also, it elevates mounted actuators for easier access. Stem extensions are available to further elevate the operating location of the valve. Please contact factory for additional information.

> **Installation Locating Holes**

Model BF 75-CI is a wafer style, one-piece body construction with four cast-in alignment holes that aid in centering the valve body to existing ASME B16.10 flanges during installation. Model BF 76-DI is lug style with tapped lugs in accordance with ASME B16.42 Class 150 specifications. Both Lug and Wafer Style valves are compatible with ANSI 125/150 bolting patterns.

> **One-Piece Through Stem Design**

The one-piece, double 'D' stem design offers exceptionally high strength, stability, dependability and accurate disc positioning. Sizes 2" through 6" are equipped with double 'D' style stems. Sizes 8" and larger utilize a round stem design with key. Valves 30" and up use a two piece stem design.

> **Applicable Standards**

Butterfly valves are designed in accordance with ASME/ANSI Class 125/150 lb class flanges as well as MSS-SP-25, MSS-SP-67, and API 609 specifications. All valves are 100% hydrostatically tested in both directions in compliance with API 598 to ensure a bubble-tight seal.



> 290 Corporate Drive > Lumberton, NC 28358
> PO Box 7408
> 910-735-0000 T > 910-738-3848 F

www.titanfci.com

titan@titanfci.com

BF 75 & BF 76 > Sizes: 2" ~ 8"

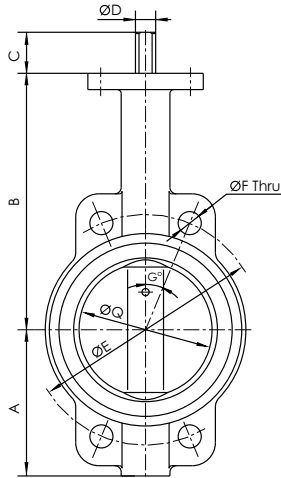

Front View
BF 75 > Wafer Style

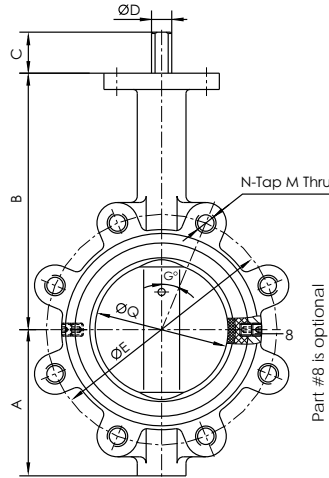

Front View
BF 76 > Lug Style

Part #8 is optional

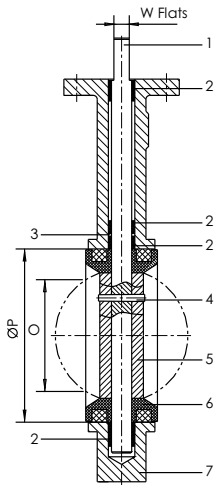

Side View
Wafer & Lug Style

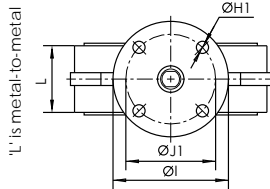

Top View 2" ~ 6"
Wafer & Lug Style

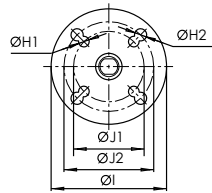

Top View 8" Only
Wafer & Lug Style

BILL OF MATERIALS ⁽¹⁾

No.	PART	WAFER STYLE	LUG STYLE
1	Stem	T-410 SS	T-410 SS
2	Bushing	PTFE	PTFE
3	O-Ring	EPDM ⁽²⁾ or Buna-N	EPDM ⁽²⁾ or Buna-N
4	Pin ⁽³⁾	T-410 SS	T-410 SS
5	Disc	Bronze or Nickel Plated	DI or CF8M T-316 SS
6	Seat ⁽⁴⁾	EPDM ⁽²⁾ or Buna-N	EPDM ⁽²⁾ or Buna-N
7	Body	Cast Iron	Ductile Iron
8	Set Screw ⁽⁵⁾	Carbon Steel	Carbon Steel

- BOM represents standard materials. Equivalent or better materials may be substituted at the manufacturer's discretion.
- EPDM is sulfur cured.
- Sizes 8" through 24" valves have two pins (Part number four).
- Seat is phenolic backed cartridge.
- Part number eight (Set Screw) is optional and only applies to Lug Style valves when customer specifies valve for dead-end service. Part number eight is not included on standard valves.

TECHNICAL NOTES

Valves are designed to comply with MSS SP-67 Type II

Valves are tested to comply with API 598

Bolting pattern conforms to Cast Iron ASME B16.1 Class 125 and Ductile Iron ASME B16.42 Class 150 ⁽¹⁾

Top flange drilling conform to ISO 5211

Maximum working pressure is 200 PSI for sizes 2" through 12"

Sizes 2" through 6" have double 'D' style stems

Sizes 8" and larger have round style stems

Valves can be made silicone free upon request

Not recommended for steam service (consult factory)

- Bolting pattern for Cast Iron ANSI Class 125 and Ductile Iron Class 150 are identical. Pressure ratings are not identical. Valves 2" ~ 12" have a maximum working pressure of 200 PSI and 14" ~ 48" have a maximum working pressure of 150 PSI. Pressure ratings are lower for dead-end service.

WEIGHT DATA ⁽¹⁾

SIZE	2 lb kg	2.5 lb kg	3 lb kg	4 lb kg	5 lb kg	6 lb kg	8 lb kg
Wafer Style	7.5 3.4	8.5 3.9	9.2 4.2	12.7 5.8	14.5 6.6	17.5 7.9	42.5 19.3
Lug Style	8.5 3.9	11.5 5.2	11.0 5.0	16.0 7.3	20.0 9.1	26.5 12.0	49.5 22.5

DIMENSIONAL DATA ⁽¹⁾

SIZE in mm	A in mm	B in mm	C in mm	D in mm	E in mm	F in mm	G Deg.	H1 in mm	H2 in mm	I in mm	J1 in mm	J2 in mm	L in mm	M ⁽²⁾ UNC	N ⁽²⁾ Qty	O ⁽³⁾ in mm	P in mm	Q in mm	W in mm
2	2.99	6.38	1.26	0.50	4.75	0.69	45	0.37	n/a	3.54	2.76	n/a	1.65	5/8 - 11	4	1.26	3.01	2.01	0.37
50	76	162	32	12.7	120.65	17.50	- - -	9.5	n/a	90	70	n/a	42	- - -	4	32	76.4	51	9.5
2 1/2	3.50	6.89	1.26	0.50	5.50	0.69	45	0.37	n/a	3.54	2.76	n/a	1.77	5/8 - 11	4	1.85	3.51	2.47	0.37
65	89	175	32	12.7	139.7	17.50	- - -	9.5	n/a	90	70	n/a	45	- - -	4	47	89.1	62.8	9.5
3	3.74	7.13	1.26	0.50	6.00	0.69	45	0.37	n/a	3.54	2.76	n/a	1.77	5/8 - 11	4	2.56	4.09	3.04	0.37
80	95	181	32	12.7	152.4	17.50	- - -	9.5	n/a	90	70	n/a	45	- - -	4	65	104	77.3	9.5
4	4.49	7.87	1.26	0.63	7.50	0.69	22.5	0.37	n/a	3.54	2.76	n/a	2.05	5/8 - 11	8	3.54	5.32	4.04	0.44
100	114	200	32	15.9	190.5	17.50	- - -	9.5	n/a	90	70	n/a	52	- - -	8	90	135.1	102.5	11.1
5	5.00	8.39	1.26	0.75	8.50	0.81	22.5	.037	n/a	3.54	2.76	n/a	2.13	3/4 - 10	8	4.37	6.26	4.80	0.50
125	127	213	32	19.1	215.9	20.60	- - -	9.5	n/a	90	70	n/a	54	- - -	8	111	159.1	121.8	12.7
6	5.47	8.86	1.26	0.75	9.50	0.81	22.5	0.37	n/a	3.54	2.76	n/a	2.20	3/4 - 10	8	5.71	7.42	6.00	0.50
150	139	225	32	19.1	241.3	20.60	- - -	9.5	n/a	90	70	n/a	56	- - -	8	145	188.5	152.4	12.7
8	6.97	10.24	1.75	0.87	11.75	0.81	22.5	0.45	0.55	5.91	4.02	4.92	2.36	3/4 - 10	8	7.60	9.38	7.91	0.63
200	177	260	44	22.2	298.45	20.60	- - -	11.5	14	150	102	125	60	- - -	8	193	238.3	200.9	15.9

- Dimensions and weights are for reference only. When required, request certified drawings. Weights for 2" ~ 8" include lever.
- Dimensions 'M' and 'N' only are applicable to Lug Style valves. Dimensions 'M' is Unified Inch Screw Thread, coarse pitch series (UNC) per ANSI B1.1. 'N' is the number of bolt holes.
- Dimension 'O' is disc chordal dimension at valve face.



BF 75 & BF 76 > Sizes: 10" ~ 24"

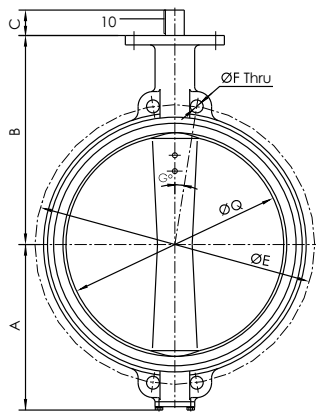

Front View
BF 75 > Wafer Style

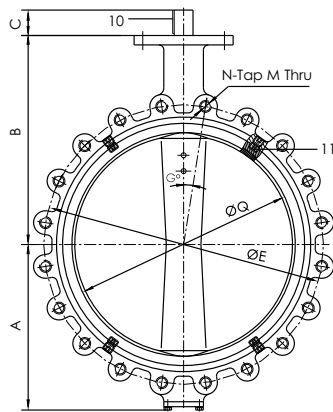

Front View
BF 76 > Lug Style

Part #11 is optional

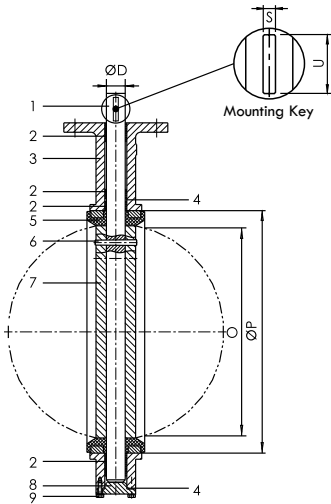

Side View
Wafer & Lug Style

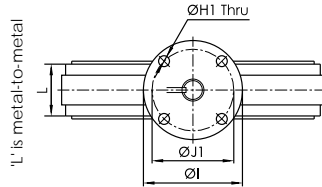

Top View 16" ~ 24"
Wafer & Lug Style

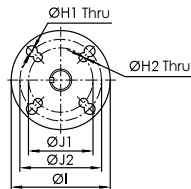

Top View 10" ~ 14"
Wafer & Lug Style

BILL OF MATERIALS ⁽¹⁾

No.	PART	WAFER STYLE	LUG STYLE
1	Stem	T-410 SS	T-410 SS
2	Bushing	PTFE	PTFE
3	Body	Cast Iron	Ductile Iron
4	O-Ring	EPDM ⁽²⁾ or Buna-N	EPDM ⁽²⁾ or Buna-N
5	Seat ⁽³⁾	EPDM ⁽²⁾ or Buna-N	EPDM ⁽²⁾ or Buna-N
6	Pin	T-410 SS	T-410 SS
7	Disc	Bronze or Nickel Plated DI or CF8M T-316 SS	
8	End Cap ⁽⁴⁾	Cast Iron	Cast Iron
9	Bolt ⁽⁴⁾	Carbon Steel	Carbon Steel
10	Key ⁽⁵⁾	Carbon Steel	Carbon Steel
11	Set Screw ⁽⁶⁾	Carbon Steel	Carbon Steel

- BOM represents standard materials. Equivalent or better materials may be substituted at the manufacturer's discretion.
- EPDM is sulfur cured.
- Seat is phenolic backed cartridge on sizes 10" ~ 14"
Seat is aluminum backed cartridge on sizes 16" ~ 24".
- Sizes 10" ~ 12" do not have End Cap (#8) or Bolt (#9).
- Sizes 10" ~ 12" have US Standard keys. Sizes 14" ~ 24" have metric keys.
- Part number eleven (Set Screw) is optional and only applies to Lug Style valves when customer specifies valve for dead-end service.

TECHNICAL NOTES

Valves are designed to comply with MSS SP-67 Type II

Valves are tested to comply with API 598

Bolting pattern conforms to Cast Iron ASME B16.1 Class 125 and Ductile Iron ASME B16.42 Class 150 ⁽¹⁾

Top flange drilling conform to ISO 5211

Max working pressure Sizes 2" ~ 12" is 200 PSI Sizes 14" ~ 48" is 150 PSI ⁽¹⁾

Sizes 8" and larger have round style stems

Valves can be made silicone free upon request

Not recommended for steam service (consult factory)

- Bolting pattern for Cast Iron Class 125 and Ductile Iron Class 150 are identical. Pressure ratings are not identical. Valves 2" ~ 12" have a max working pressure of 200 PSI and 14" ~ 48" have a max working pressure of 150 PSI. Pressure ratings are lower for dead-end service (See page six).

WEIGHT DATA ⁽¹⁾

SIZE	10 lb kg	12 lb kg	14 lb kg	16 lb kg	18 lb kg	20 lb kg	24 lb kg
Wafer Style	54.0 24.5	88.2 40.0	98.0 44.5	162.0 73.5	188.0 85.3	341.8 155.0	529.2 240.0
Lug Style	80.0 36.3	110.0 49.9	130.0 59.0	220.0 99.8	232.0 105.2	322.0 146.1	522.0 236.8

DIMENSIONAL DATA ⁽¹⁾

SIZE in mm	A in mm	B in mm	C in mm	D in mm	E in mm	F in mm	G Deg.	H1 in mm	H2 in mm	I in mm	J1 in mm	J2 in mm	L in mm	M ⁽²⁾ UNC	N ⁽²⁾ Qty	O ⁽³⁾ in mm	P in mm	Q in mm	S x U in mm
10 250	7.99 203	11.50 292	1.50 38	1.13 28.6	14.25 361.95	0.94 23.80	15 ---	0.55 14	0.45 11.5	5.91 150	4.02 102	4.92 125	2.60 66	7/8 - 9 ---	12 12	9.49 241	11.52 292.5	9.80 248.9	- - - 8 x 36.2 ⁽⁴⁾
12 300	9.53 242	13.27 337	1.87 47	1.25 31.8	17.00 431.8	0.94 23.80	15 ---	0.55 14	0.45 11.5	5.91 150	4.02 102	4.92 125	2.99 76	7/8 - 9 ---	12 12	11.46 291	13.55 344.2	11.81 299.9	- - - 8 x 36.2 ⁽⁴⁾
14 350	11.02 280	14.49 368	1.77 45	1.25 31.8	18.75 476.25	1.06 27.0	15 ---	0.55 14	0.45 11.5	5.91 150	4.02 102	4.92 125	2.99 76	1 - 8 ---	12 12	12.80 325	14.78 375.3	13.06 331.7	- - - 8 x 36.2 ⁽⁴⁾
16 400	12.20 310	15.75 400	1.77 45	1.31 33.3	21.25 539.75	1.06 27.0	11.25 ---	0.87 22	n/a n/a	8.27 210	6.50 165	n/a n/a	3.39 86	1 - 8 ---	16 16	14.96 380	17.30 439.5	15.26 387.5	- - - 10 x 50
18 450	13.58 345	16.61 422	2.01 51	1.50 38.1	22.75 577.85	1.25 31.80	11.25 ---	0.87 22	n/a n/a	8.27 210	6.50 165	n/a n/a	4.13 105	1 1/8 - 7 ---	16 16	16.85 428	19.31 490.5	17.26 438.4	- - - 10 x 50
20 500	14.88 378	18.86 479	2.52 64	1.63 41.3	25.00 635	1.25 31.80	9 ---	0.87 22	n/a n/a	8.27 210	6.50 165	n/a n/a	5.12 130	1 1/8 - 7 ---	20 20	18.66 474	21.08 535.4	19.28 489.6	- - - 10 x 50
24 600	18.11 460	22.13 562	2.76 70	2.00 50.8	29.50 749.3	1.37 34.9	9 ---	0.87 22	n/a n/a	8.27 210	6.50 165	n/a n/a	5.94 151	1 1/4 - 7 ---	20 20	22.64 575	25.76 654.4	23.23 590.1	- - - 16 x 56

- Dimensions and weights are for reference only. When required, request certified drawings. Weights for 10" ~ 24" include gear operator.
- Dimensions 'M' and 'N' only are applicable to Lug Style valves. Dimension 'M' is Unified Inch Screw Thread, coarse pitch series (UNC) per ANSI B1.1. 'N' is number of bolt holes.
- Dimension 'O' is disc chordal dimension at valve face.
- Sizes 10" through 14" have a Woodruff Mounting Key. Contact factory for additional mounting dimensions and information for these sizes.



> 290 Corporate Drive > Lumberton, NC 28358
> 910-735-0000 T > 910-738-3848 F

www.titanfci.com
titan@titanfci.com

BF 75 & BF 76 > Sizes: 30" ~ 48"

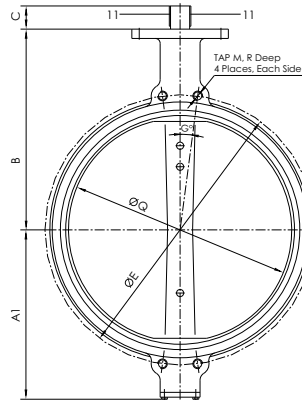

Front View
BF 75 > Wafer Style

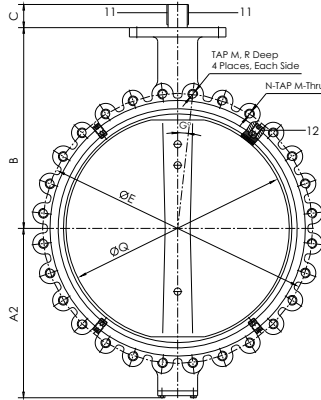

Front View
BF 76 > Lug Style

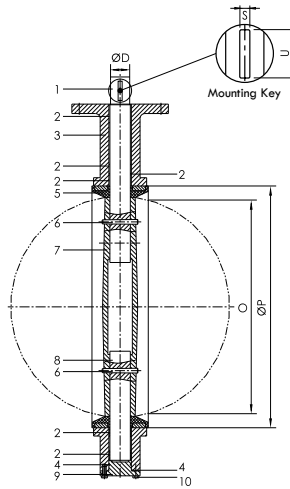

Side View
Wafer & Lug Style

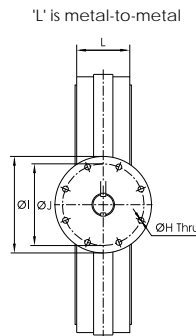

Top View
Wafer & Lug Style

BILL OF MATERIALS ⁽¹⁾			
No.	PART	WAFER STYLE	LUG STYLE
1	Upper Stem	T-410 SS	T-410 SS
2	Bushing	PTFE	PTFE
3	Body	Cast Iron	Ductile Iron
4	O-Ring	EPDM ⁽²⁾ or Buna-N	EPDM ⁽²⁾ or Buna-N
5	Seat ⁽³⁾	EPDM ⁽²⁾ or Buna-N	EPDM ⁽²⁾ or Buna-N
6	Pin	T-410 SS	T-410 SS
7	Disc	Bronze or Nickel Plated DI or CF8M T-316 SS	
8	Lower Stem	T-410 SS	T-410 SS
9	End Cap	Cast Iron	Ductile Iron
10	Bolt	Carbon Steel	Carbon Steel
11	Key	Carbon Steel	Carbon Steel
12	Set Screw ⁽⁴⁾	Carbon Steel	Carbon Steel

- BOM represents standard materials. Equivalent or better materials may be substituted at the manufacturer's discretion.
- EPDM is sulfur cured.
- Seat is aluminum backed cartridge on sizes 30" ~ 48".
- Sizes 30" ~ 48" have metric keys.
- Part number twelve (Set Screw) is optional and only applies to Lug Style valve when customer specifies valve for dead-end service. Part number twelve is not included with standard valves.

TECHNICAL NOTES

Valves are designed to comply with MSS SP-67 Type II

Valves are tested to comply with API 598

Bolting pattern conforms to Cast Iron ASME B16.1 Class 125 and Ductile Iron ASME B16.42 Class 150 ⁽¹⁾

Top flange drilling conform to ISO 5211

Max working pressure: 2" ~ 12" is 200 PSI 14" ~ 48" is 150 PSI ⁽¹⁾

Sizes 2" ~ 6" have Double 'D' stems, Sizes 8" ~ 48" have round stems

Valves can be made silicone free upon request

Not recommended for steam service (consult factory)

- Bolting pattern for Cast Iron Class 125 and Ductile Iron Class 150 are identical. Pressure ratings are not identical. Valves 2" ~ 12" have a max working pressure of 200 PSI and 14" ~ 48" have a max working pressure of 150 PSI. Pressure ratings are lower for dead-end service.

WEIGHT DATA ⁽¹⁾

SIZE	30	36	42	48
	lb kg	lb kg	lb kg	lb kg
Wafer Style	837.9 380.0	1301.0 590.0	1775.0 805.0	2646.0 1200.0
Lug Style	1036.4 470.0	1697.9 770.0	2183.0 990.0	3307.5 1500.0

DIMENSIONAL DATA ⁽¹⁾

SIZE	A1	A2	B ⁽²⁾	C	D	E	G	H	I	J	L	M ⁽³⁾	N ⁽³⁾	R ⁽³⁾	O ⁽⁴⁾	P	Q	S x U
in mm	in mm	in mm	in mm	in mm	in mm	in mm	Deg.	in mm	in mm	in mm	in mm	UNC	in mm	in mm	in mm	in mm	in mm	in mm
30	20.39	24.61	25.47	2.83	2.17	36	6.43 °	0.71	11.81	10.00	6.57	1 1/4 - 7	28	1.57	28.58	31.29	29.19	- - -
750	518	625	647	72	55	914.4	- - -	18	300	254	167	- - -	28	40	726	794.7	741.3	16 x 63
36	25.31	24.33	30.24/26.69	3.03	2.95	42.75	5.63 °	0.71	11.81	10.00	8.15	1 1/2 - 6	32	1.77	33.03	37.28	33.90	- - -
900	643	618	768/678	77	75	1085.9	- - -	18	300	254	207	- - -	32	45	839	947	861	20 x 70
42	30.31	30.31	33.86	3.35	3.35	49.5	5.00 °	0.71	11.81	10.00	10.08	1 1/2 - 6	36	1.97	39.25	44.27	40.41	- - -
1050	770	770	860	85	85	1257.3	- - -	18	300	254	256	- - -	36	50	997	1124.5	1026.4	22 x 70
48	33.46	33.46	37.01	5.91	3.62	56.00	4.09 °	0.87	13.78	11.73	10.87	1 1/2 - 6	44	2.17	44.29	49.77	45.52	- - -
1200	850	850	940	150	92	1422.4	- - -	22	350	298	276	- - -	44	55	1125	1264.1	1156.1	25 x 140

- Dimensions and weights are for reference only. When required, request certified drawings. Weights for 30" ~ 48" include gear operator.
- Dimension 'B' is the same on both Wafer and Lug Styles except on the 36". On the 36" Wafer Style, Dimension B is 30.24 in (768 mm); On the 36" Lug Style, Dimension 'B' is 26.69 in (678 mm).
- Dimension 'N' is applicable to Lug Style valves. Dimension 'M' is Unified Inch Screw Thread, coarse pitch series (UNC) per ANSI B1.1.
- Dimension 'O' is disc chordal dimension at valve face.



Valve Handles Sizes: 2" ~ 12"

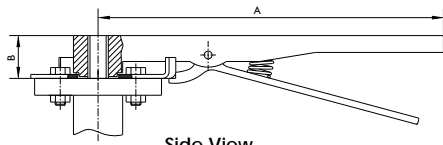

Side View
Sizes 2" ~ 6"

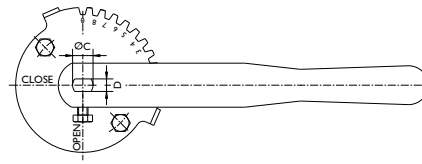

Top View
Sizes 2" ~ 6"

Handles and mounting plates have holes drilled in them which can be used to lock the valve in the open or closed position.

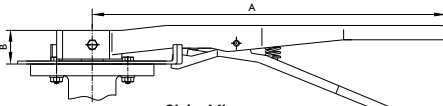

Side View
Sizes 8" ~ 12"

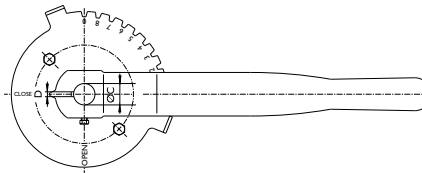

Top View
Sizes 8" ~ 12"

DIMENSIONAL DATA ⁽¹⁾					
SIZE in mm	A in mm	B in mm	C in mm	D in mm	Weight lb kg
2 ~ 3	10.51	1.26	0.50	0.38	3.00
50 ~ 75	267	32	12.7	9.53	1.36
4	10.51	1.26	0.63	0.44	3.00
100	267	32	15.88	11.13	1.36
5 ~ 6	10.51	1.26	0.75	0.50	3.00
125 ~ 150	267	32	19.05	12.7	1.36
8	14.02	1.50	0.88	- - -	5.00
200	356	38	22.23	5	2.27
10	14.02	1.50	1.13	- - -	5.00
250	356	38	28.58	8	2.27
12	14.02	1.50	1.25	- - -	5.00
300	356	38	31.75	8	2.27

1. Dimensions and weights are for reference only. When required, request certified drawings.

Titan FCI makes every effort to ensure the information presented on our literature accurately reflects exact product specifications. However, as changes occur, there may short-term differences between actual product specifications and the information shown on our literature. Titan FCI reserves the right to make specification changes to improve our products without prior notification.

Gear Operators Sizes: 2" ~ 18"

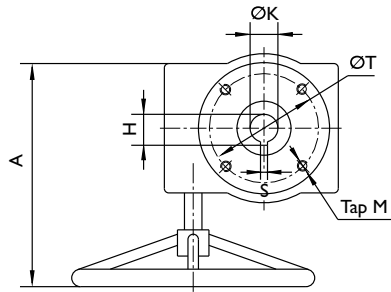

Top View
Sizes 2" ~ 18"

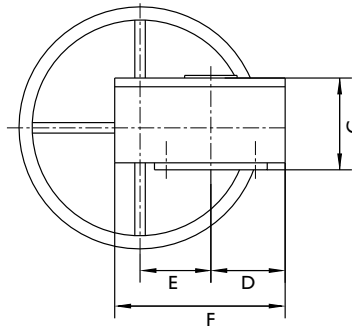

Back View
Sizes 2" ~ 18"

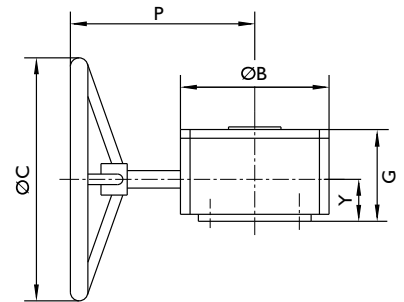

Side View
Sizes 2" ~ 18"

DIMENSIONAL DATA ⁽¹⁾																	
SIZE in mm	A in mm	B in mm	C in mm	D in mm	E in mm	F in mm	G in mm	P in mm	Y in mm	K in mm	H in mm	S in mm	T in mm	M in mm	Weight lb kg	Torque lb-in N-m	Ratio
2 ~ 3	9.06	4.13	5.91	2.09	1.77	4.92	2.44	7.01	1.50	0.50	0.56	- - -	1.97	- - -	13.23	1505	24:1
50 ~ 75	230	105	150	53	45	125	62	178	38	12.7	14.1	3	50	M6	6.00	170	
4	9.06	4.13	5.91	2.09	1.77	4.92	2.44	7.01	1.50	0.63	0.72	- - -	2.76	- - -	13.23	1505	24:1
100	230	105	150	53	45	125	62	178	38	15.9	18.2	5	70	M8	6.00	170	
5 ~ 6	9.06	4.13	5.91	2.09	1.77	4.92	2.44	7.01	1.50	0.75	0.84	- - -	2.76	- - -	13.23	1505	24:1
125 ~ 150	230	105	150	53	45	125	62	178	38	19.05	21.35	5	70	M8	6.00	170	
8	12.20	6.22	11.81	2.99	2.48	6.85	3.07	9.25	1.65	0.87	0.96	- - -	4.02	- - -	30.86	6638	30:1
200	310	158	300	76	63	174	78	235	42	22.2	24.5	5	102	M10	14.00	750	
10	12.2	6.22	11.81	2.99	2.48	6.85	3.07	9.25	1.65	1.13	1.26	- - -	4.02	- - -	30.86	6638	30:1
250	310	158	300	76	63	174	78	235	42	28.6	31.9	8	102	M10	14.00	750	
12 ~ 14	12.01	6.69	11.81	3.19	3.19	7.68	3.15	8.90	1.61	1.25	1.38	- - -	4.02	- - -	35.27	10621	50:1
300 ~ 350	305	170	300	81	81	195	80	226	41	31.8	35.1	8	102	M10	16.00	1200	
16	12.48	8.27	14.17	4.92	3.74	10.01	4.13	8.54	1.89	1.31	1.44	- - -	6.50	- - -	99.21	22127	80:1
400	317	210	360	125	95	255	105	217	48	33.3	36.6	10	165	M20	45.00	2500	
18	12.48	8.27	14.17	4.92	3.74	10.04	4.13	8.54	1.89	1.50	1.63	- - -	6.50	- - -	99.21	22127	80:1
450	317	210	360	125	95	255	105	217	48	38.1	41.4	10	165	M20	45.00	2500	

1. Dimensions and weights are for reference only. When required, request certified drawings.

Gear Operators Sizes 20" ~ 24"

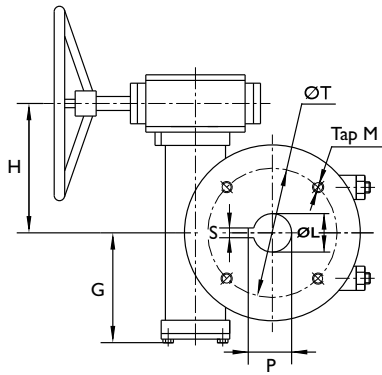

Top View
Sizes 20" ~ 24"

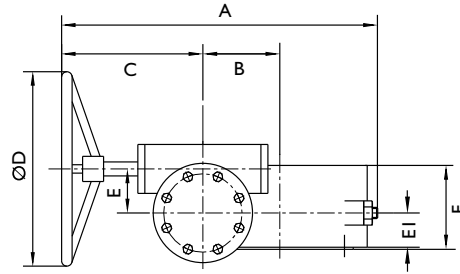

Side View
Sizes 20" ~ 24"

DIMENSIONAL DATA ⁽¹⁾

SIZE in mm	A in mm	B in mm	C in mm	D in mm	E in mm	E1 in mm	F in mm	G in mm	H in mm	T in mm	N/M in mm	L in mm	S in mm	P in mm	Weight lb kg	Torque lb-in N-m	Ratio
20	18.90	4.33	8.27	14.17	2.48	2.05	4.72	6.30	7.28	6.50	- - -	1.63	- - -	1.76	143.30	26552	352:1
500	480	110	210	360	63	52	120	160	185	165	M20	41.3	10	44.6	65	3000	
24	20.47	4.92	8.27	14.17	2.48	2.24	4.72	6.30	7.28	6.50	- - -	2.00	- - -	2.17	158.73	35403	416:1
600	520	125	210	360	63	57	120	160	185	165	M20	50.8	16	55.1	72	4000	

1. Dimensions and weights are for reference only. When required, request certified drawings.

Stem Extensions & Chain Wheels

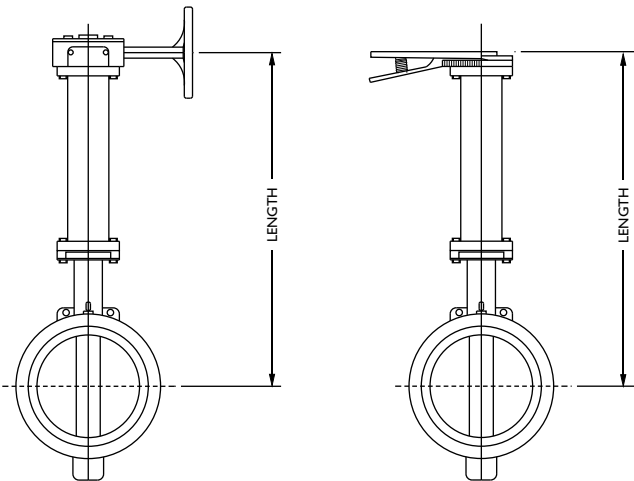

> Stem Extensions

Stem extensions are utilized to elevate the operating location of the butterfly valve. The top mounting pad of the stem extension provides the same dimensions as the valve's mounting pad. This ensures a universal mounting flange that can accommodate all types of operators (10-position handle kits, gear operators, electric actuators, or pneumatic actuators).

Stem Extensions can be fabricated from carbon or stainless steel and range in length from three inches to sixteen feet. Beyond the upper limit, the structural integrity of the valve stem becomes a factor and requires special design consideration. Please contact the factory direct for pre-sales design assistance.

> Chain Wheels

The primary purpose of a chain wheel actuator is to provide ground level control of hard-to-reach valves. This capability saves time and helps minimize the risk of personal injury during valve operations. Chain wheels are available in a variety of materials and configurations. Please contact the factory so we can recommend the appropriate chain wheel configuration for your specific application.

The picture to the right shows how an adjustable sprocket rim can be fastened to the round hand wheel of a gear operator.

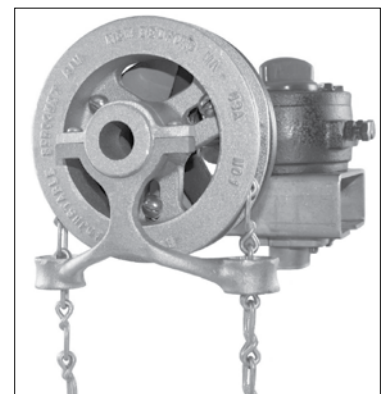

Butterfly Valve Seating and Unseating Valve Torque Ratings

Valve Sizes		Full Rated Pressure Ratings (Torque for psi is expressed as in-lb, Torque for MPa is expressed as N-m)										Correction Factors
in	mm	50 psi	0.4 MPa	100 psi	0.6 MPa	150 psi	1.0 MPa	200 psi	1.4 MPa	250 psi	1.6 MPa	
2	50	99	10	105	14	111	14	117	13	121	15	The following guidelines may be used to estimate torque values for other types of service. For Dry Service: Multiply by 160% For Lubricated Service: Multiply by 85% For Actuator Sizing: First apply the correction factor for the type of service then use the additional correction factors Multiply by 150% (Single Valve Application) Multiply by 200% (Three way applications)
2.5	65	150	15	163	21	175	23	189	21	196	24	
3	80	206	20	219	28	232	30	243	27	250	30	
4	100	289	28	322	42	357	46	389	43	410	50	
5	125	422	41	481	62	540	70	597	66	643	78	
6	150	598	58	690	90	782	102	874	97	935	114	
8	200	1059	103	1182	154	1306	170	1429	159	1517	185	
10	250	1670	163	1872	243	2074	269	2275	253	2403	292	
12	300	2568	250	2794	363	3023	392	3248	361	3401	414	
14	350	2639	257	3069	399	3500	454	3964	441	4267	519	
16	400	4260	415	4879	634	5500	714	5987	666	6280	764	
18	450	6287	612	7243	940	8199	1065	9183	1022	9817	1195	
20	500	8360	814	9180	1192	10000	1298	10859	1208	11409	1389	
24	600	15427	1502	16813	2183	18200	2363	18728	2084	19155	2332	
30	750	27313	2660	29407	3818	31500	4090	33530	3731	34844	4241	
36	900	54667	5323	57034	7405	59399	7712	61793	6877	63351	7711	
42	1050	82460	8030	86034	11170	89600	11633	- - -	- - -	- - -	- - -	
48	1200	108015	10518	112704	14633	117376	15239	122101	13588	125177	15236	

The above torques are for reference only. They were calculated from test data using clean, wet fluids (i.e. water) at ambient temperatures during on/off service. During actual service, hydrodynamic torque may meet or exceed the above listed seating and unseating torques. Therefore, hydrodynamic torque must be considered during system design to ensure proper valve and actuator selection. As always, a Titan FCI application engineer is ready to assist with valve and actuator selection.

Pressure Ratings (Bidirectional)

2" ~ 12"	200 psig	14 bar
14" ~ 24"	150 psig	10 bar

Butterfly Valve is mated between two flanges for bidirectional service and the disc is in the closed position.

Pressure Ratings (Dead-End)

2" ~ 12"	150 psig	10 bar
14" ~ 24"	100 psig	7 bar

Butterfly Valve is installed for dead-end service without a downstream flange. Disc is in the closed position. Please note, standard valves are not designed for dead-end service. Dead-end service must be specified by the customer.

Flow Rate Limits (On/Off Service)

Fluids	20 ft/sec	6 m/sec
Gases	175 ft/sec	54 m/sec

This table lists velocity limits for on/off services only. Additionally, for throttling service, the flow velocity should not exceed 20 ft/sec for liquids and 175 ft/sec for gases.

Seat Material Temperature Ratings

Buna-N	+10 ~ 180 °F	-12 ~ 82 °C
EPDM	-30 ~ 225 °F	-34 ~ 107 °C

This table lists the theoretical temperature limits for elastomers. During actual service, hardening of the elastomer may cause the torque to exceed the structural limits of the valve.

Butterfly Valve C_v Flow Coefficient Values (GPM @ 1ΔP)

Valves Sizes		Angle of Valve Disc Rotation									
in	mm	10°	20°	30°	40°	50°	60°	70°	80°	90°	
2	50	0.06	3	7	15	27	44	70	105	115	
2.5	65	0.10	6	12	25	45	75	119	178	196	
3	80	0.20	9	18	39	70	116	183	275	302	
4	100	0.30	17	36	78	139	230	364	546	600	
5	125	0.50	29	61	133	237	392	620	930	1022	
6	150	0.80	45	95	205	366	605	958	1437	1579	
8	200	2	89	188	408	727	1202	1903	2854	3136	
10	250	3	151	320	694	1237	2049	3240	4859	5340	
12	300	4	234	495	1072	1911	3162	5005	7507	8250	
14	350	6	338	715	1549	2761	4568	7230	10844	11917	
16	400	8	464	983	2130	3797	6282	9942	14913	16388	
18	450	11	615	1302	2822	5028	8320	13168	19752	21705	
20	500	14	791	1647	3628	6465	10698	16931	25396	27908	
24	600	22	1222	2587	5605	9989	16528	26157	39236	43116	
30	750	37	2080	4406	9546	17010	28147	44545	66818	73246	
36	900	260	3050	6730	12740	20220	32500	52500	79600	87500	
40	1000	313	3665	8089	15942	2429	39056	63093	95660	105154	
42	1050	350	4095	9040	17108	27150	43640	70500	106890	117500	
48	1200	455	5365	11840	22400	30600	51200	92300	140000	154000	

This chart can be used as a guide only due to the numerous variations of flow conditions that may occur during actual service.

C_v Equation For Liquids

$$C_v = Q * \sqrt{\frac{G}{\Delta P}}$$

C_v = Flow Coefficient

G = Specific Gravity of liquid at 60 °F

Q = Flow rate in U.S. gallons per minute (GPM)

ΔP = Pressure drop in pounds per square inch (PSI)

The Flow Coefficient (designated as C_v) is a physical measurement that specifies the number of gallons per minute (GPM) that can pass through a piping component, at room temperature, and create a one (1) psi differential (ΔP) across the piping component.

HOW TO ORDER

Series	Code	Body Material	Code	Stem Material	Code	Disc Material	Code	Seat Material	Code	Actuator	Code	
200 PSI Wafer Type	BF75	Cast Iron *	CI	Stainless Steel * Type 410	R	Nickle Plated * Ductile Iron	D	Buna-N *	B	Bare Stem	O	
200 PSI Lug Type	BF76	Ductile Iron *	DI	Stainless Steel Type 316	S	Aluminum * Bronze	B	EPDM *	E	10 Position Handle	L	
200 PSI Lug Type Dead End Service	BF76D	Carbon Steel	CS			Stainless Steel * Type 316	S	Viton	V	Infinite Handle	I	
		Stainless Steel	SS			Special	X	Teflon	T	Gear Operator	G	
									Special	X	Chain Wheel	C
											Actuated	A

Notes:

1. Not all configurations are readily available. Please contact factory. (*) Denotes standard materials.
2. Other seat materials can be provided. Please contact factory.
3. Other body materials can be provided. Please contact factory.

ORDERING EXAMPLE:

PART NUMBER: 8.0-BF75-CI-R-B-B-G

DESCRIPTION: 8" Wafer Style Butterfly Valve, Cast Iron Body, 410 Stainless Steel Stem, Bronze Disc, Buna-N Seat, and Gear Operator

Flange Bolting Information

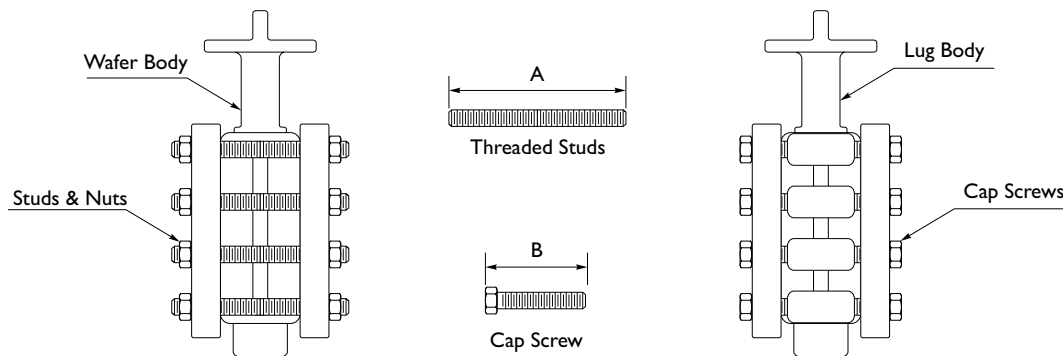

WAFER STYLE FLANGE BOLT DATA - WITH THREADED STUDS ⁽¹⁾

Valve Size	Quantity Per Valve	Bolt Size	Stud Bolt Length "A"
2	4	5/8" - 11	4.75
2.5	4	5/8" - 11	5.25
3	4	5/8" - 11	5.25
4	8	5/8" - 11	5.5
5	8	3/4" - 10	6
6	8	3/4" - 10	6
8	8	3/4" - 10	6.5
10	12	7/8" - 9	7
12	12	7/8" - 9	7.75
14	12	1" - 8	8.25
16	16	1" - 8	8.75
18	16	1 1/8" - 7	10
20	20	1 1/8" - 7	11
24	20	1 1/4" - 7	12.75

1. Flange bolting information is in accordance with ASME 16.5 Class 150 specifications.

LUG STYLE FLANGE BOLT DATA - WITH CAP SCREWS ⁽¹⁾

Valve Size	Quantity Per Valve	Bolt Size	Cap Screw Length "B"
2	8	5/8" - 11	1.25
2.5	8	5/8" - 11	1.5
3	8	5/8" - 11	1.5
4	16	5/8" - 11	1.75
5	16	3/4" - 10	1.75
6	16	3/4" - 10	1.75
8	16	3/4" - 10	2
10	24	7/8" - 9	2.25
12	24	7/8" - 9	2.5
14	24	1" - 8	2.75
16	32	1" - 8	3
18	32	1 1/8" - 7	3.5
20	40	1 1/8" - 7	4
24	40	1 1/4" - 7	4.75

1. Flange bolting information is in accordance with ASME 16.5 Class 150 specifications.



Your Pipeline to the Future



TITAN FLOW CONTROL

290 Corporate Drive • Lumberton, NC 28358

TITAN CHECK VALVES

Titan Flow Control, Inc. is a high quality manufacturer of check valves. With a dedication to great customer service, cutting edge engineering, and top quality products, Titan Flow Control's Check Valves are the preferred choice for achieving automatic shut-off and preventing backflow in piping systems.

Titan is committed to maintaining a large inventory of silent check valves, center guided check valves, double disc check valves, and single disc check valves in a variety of types, sizes, materials, and pressure classes.



*At Titan Flow Control, you get the
right check valve
and you get it right away!*

CALL
(910) 735-0000

FAX
(910) 738-3848

VISIT
www.titanfci.com

EMAIL
titan@titanfci.com

TITAN CHECK VALVE FEATURES

TITAN

Check Valves are automatic shut-off valves that are commonly used for preventing backflow or drainage in a piping system. Often applied on the discharge side of pumps, check valves prevent the system from draining if the pump stops and protect against backflow, which could harm the pump or other equipment.

Titan Flow Control offers the following types of check valves to meet your specific needs:

CENTER-GUIDED CHECK VALVES

STRAIGHTENING VANES
reduce turbulence in incoming flow, minimizing vibrations that could result in premature valve failure

INTERCHANGEABLE SEATS AND SPRINGS
are available in a wide variety of materials

ADDITIONAL GASKET
independent of the flange gasket is assembled with the seat to improve sealing

Center Guided - Globe Style

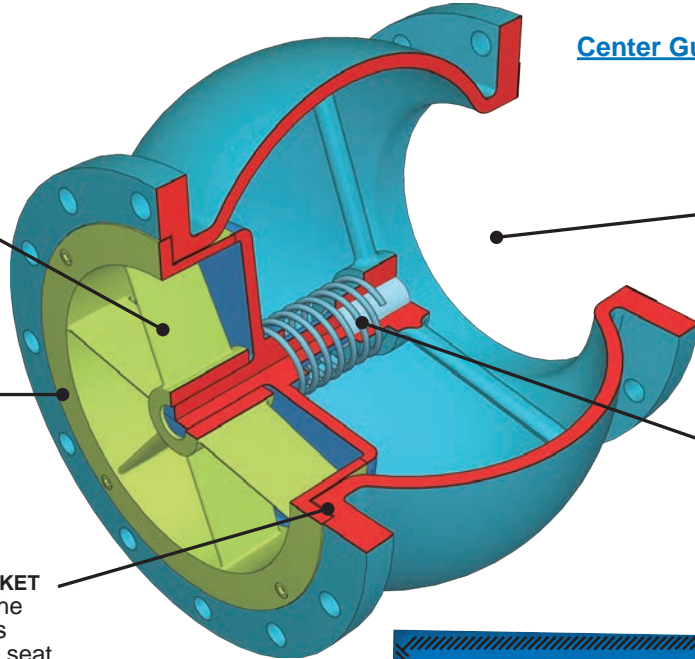

CLEARANCE WITHIN VALVE'S BODY
allows a butterfly valve to be installed on the outlet side without a spool piece

COMPRESSION SPRING
coupled with a small stem guide provides less obstruction to the flow than a typical conical construction

SUPERIOR QUALITY CHECK VALVES? **CHECK.**
WIDE VARIETY OF AVAILABLE OPTIONS IN STOCK? **CHECK.**
UNBEATABLE PRICING? **CHECK.**
FRIENDLY AND HELPFUL CUSTOMER SERVICE? **CHECK.**

TITAN FLOW VALVES.



Center Guided - Wafer Style

SOFT AND METAL SEATS
are available to meet the sealing needs of various applications

SHORT DISC TRAVEL
reduces the risk of slamming and the potential for water hammer

COMPACT DESIGN
is economical and takes up less space in pipeline than globe style check valves

LARGE CROSS-SECTIONAL AREA
exceeds that of the pipeline to minimize head loss

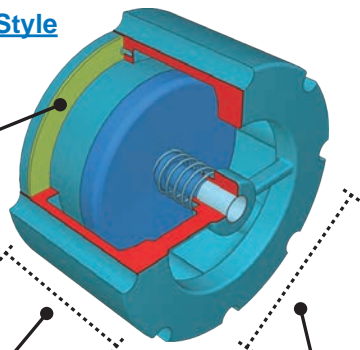

Center Guided - Threaded

RESILIENT SEATS
with precision machined sealing surfaces maintain a bubble tight seal

SHORT, STRAIGHT FLOW PATH
across valve generates little turbulence

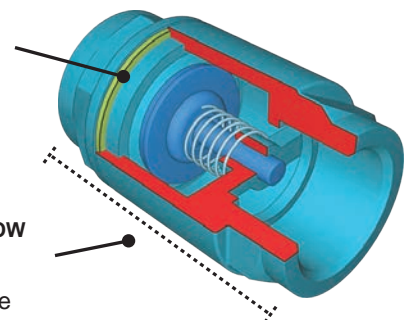

DUAL DISC CHECK VALVES

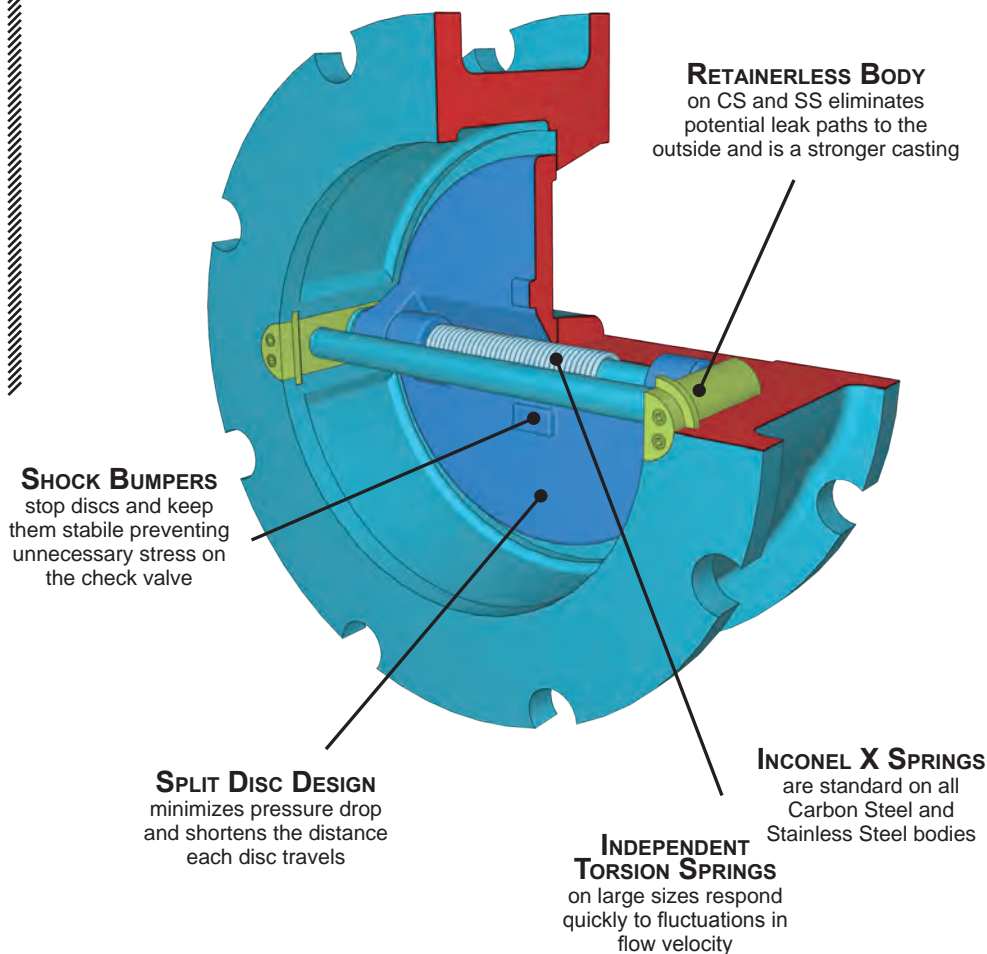

Advantages of **DUCTILE IRON CHECK VALVES**

Titan Check Valves are made with the alloy Ductile Iron for prices that are comparable to Cast Iron! Ductile Iron is composed of graphite in spheroidal shapes compared to Cast Iron, which has lenticular flakes that make it brittle. Not only does Ductile Iron have a yield strength comparable to Carbon Steel, but it also has the anti-corrosive properties of cast iron, making it the preferred material for iron check valves.

SINGLE DISC CHECK VALVES

Single Disc - Wafer Style

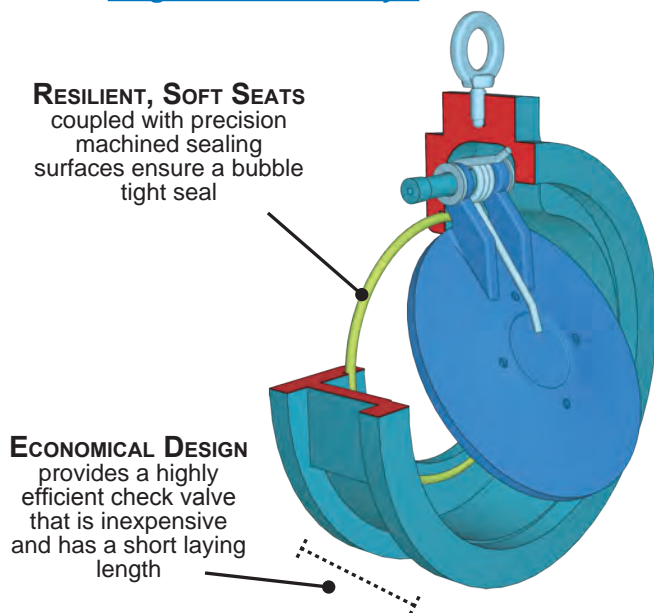

Single Disc - Short Pattern

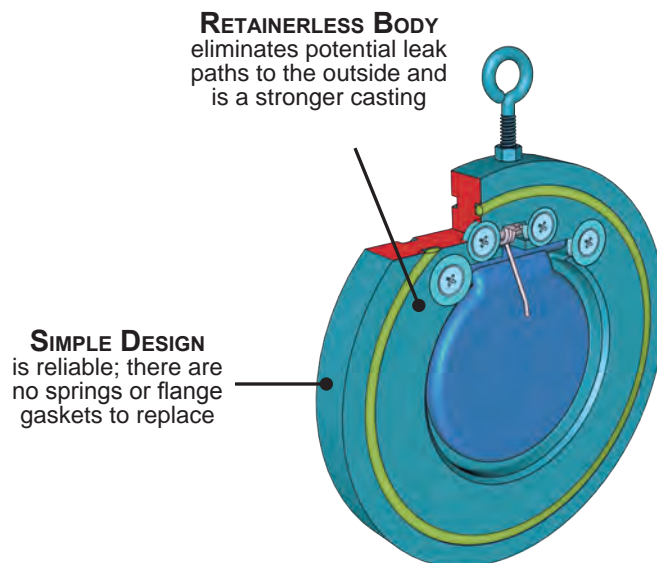

CALL
(910) 735-0000

FAX
(910) 738-3848

EMAIL
titan@titanfci.com

VISIT
www.titanfci.com

CALL
(910) 735-0000

FAX
(910) 738-3848

VISIT
www.titanfci.com

EMAIL
titan@titanfci.com

TITAN CHECK VALVES

TITAN

Double Disc Wafer Style



CV 41 - DI	Wafer	Class 150	Ductile Iron	Sizes 2" - 48"
CV 42 - CS/SS	Wafer	Class 150	Carbon or Stainless	Sizes 2" - 48"
CV 42L - CS/SS	Lug	Class 150	Carbon or Stainless	Sizes 2" - 48"
CV 44 - CS/SS	Wafer	Class 300	Carbon or Stainless	Sizes 2" - 48"
CV 46 - CC/SS	Wafer	Class 600	Carbon or Stainless	Sizes 2" - 48"
CV 47 - CC/SS	Wafer	Class 900	Carbon or Stainless	Sizes 2" - 48"

Single Disc Wafer Style

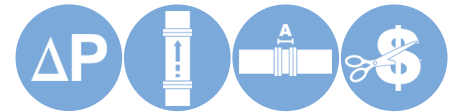

CV 31 - DI	Wafer	Class 150	Ductile Iron	Sizes 2" - 12"
CV 32 - CS/SS	Wafer	Class 150	Carbon or Stainless	Sizes 2" - 12"

Single Disc Short Pattern Wafer

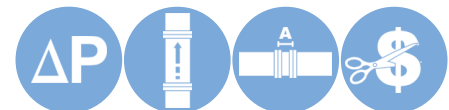

CV 12 - CS/SS	Short Wafer	Class 150	Carbon or Stainless	Sizes 2" - 24"
---------------	-------------	-----------	---------------------	----------------

KEY FEATURES FOR COMPARISON



Minimal Slam Designed to minimize slamming potential	Minimal ΔP Designed to minimize head loss across valve	Buried Service May be used for buried service; valve box recommended upward position	Vertical - Up May be used vertically, only in an upward position	Up & Down May be used in downward position with non-standard spring; C/F	High Pressure Pressures higher than 300 PSI are available	High Velocities May be used for velocities higher than 15 FPS	Short Length Short face-to-face takes up minimal space in pipeline	Low Cost Relatively low initial cost
--	--	--	--	--	---	---	--	--

Single Disc Swing Check

CV 31F/WF Flanged Class 125 Cast Iron Sizes 2" - 12"



Center Guided Globe Style

CV 50 - DI Globe Class 150 Ductile Iron Sizes 2" - 36"

CV 51 - CS/SS Globe Class 150 Carbon or Stainless Sizes 2" - 36"

CV 52 - DI Globe Class 300 Ductile Iron Sizes 2" - 36"

CV 52 - CS/SS Globe Class 300 Stainless Steel Sizes 2" - 36"



Center Guided Wafer Style

CV 90 - DI Wafer Class 150 / 300 Ductile Iron Sizes 2" - 12"

CV 91 - SS Wafer Class 150 / 300 Stainless Steel Sizes 2" - 12"



As part of Titan Flow Control's dedication to cutting edge design, Titan's Engineering Department developed the patent pending CV 50 series of center guided, globe style, check valves. Only Titan's CV 50 series have integral straightening vanes to calm turbulent flows, smaller stem guides for less flow obstruction, and extra clearance to allow direct butterfly valve installation on the outlet side.

Center Guided Threaded

CV 20 - BR Threaded WOG 400 Bronze Sizes 1/4" - 2"

CV 80 - SS Threaded Class 300 Stainless Steel Sizes 3/8" - 3"



TECHNICAL INFORMATION

TITAN

DESIGN SPECIFICATIONS

The following specifications are referenced in the design of Titan Flow Control, Inc's Check Valves. Please contact a Titan Engineer with any questions about design requirements or specifications.

API 594	General Valve Design	ASME B16.34	Flanged, Threaded, and Welding Ends
API 598	Valve Pressure Testing and Inspection	ASME B16.42	Ductile Iron Pipe Flanges
API 6A	Production Valves	ASME B16.47	Large Diameter Steel Flanges
API 6D	Pipeline Valves	ASME B31.1	Power Piping
ASME B16.1	Cast Iron Pipe Flanges & Flanged Fittings	ASTM	Material Specifications
ASME B16.5	Pipe Flanges and Flanged Fittings	MSS SP-6	Finishes for Connecting End Flanges
ASME B16.10	Face-to-Face & End-to-End Dimensions	MSS SP-25	Standard Marking System for Valves
ASME B16.24	Cast Copper Alloy Pipe Flanges	MSS SP-55	Quality Standard for Valve Castings

FACTORS FOR CONSIDERATION

Water Hammer

The term water hammer refers to a pressure surge in a pipeline that is created when a closing check valve stops reverse flow suddenly. This surge causes a slamming sound and it potentially can damage pipelines and buildings that house the pipelines, especially when the fluid has a high velocity or mass or when the pipeline's elevation fluctuates greatly.

Because quick closure is the key to the prevention of water hammer, it is important to consider the speed at which the check valve will close and the distance it has to travel to close. Features like Titan's independent torsion springs on large double disk check valves allow the valves to respond quickly to fluctuations in pipeline flow. As illustrated below, because a center guided check valve that is almost closed will only have a small amount of reverse flow, water hammer is less likely in any specific application. Conversely, a single disc or double disc check valve's flow rate may be greater than its percentage open, meaning that more reverse flow is present. Consult Titan with any concerns or questions about water hammer before selecting a check valve.

Center-guided Check Valves
A.K.A
"SILENT"
Check Valves
because they are
less likely to SLAM
as a result of
water hammer!

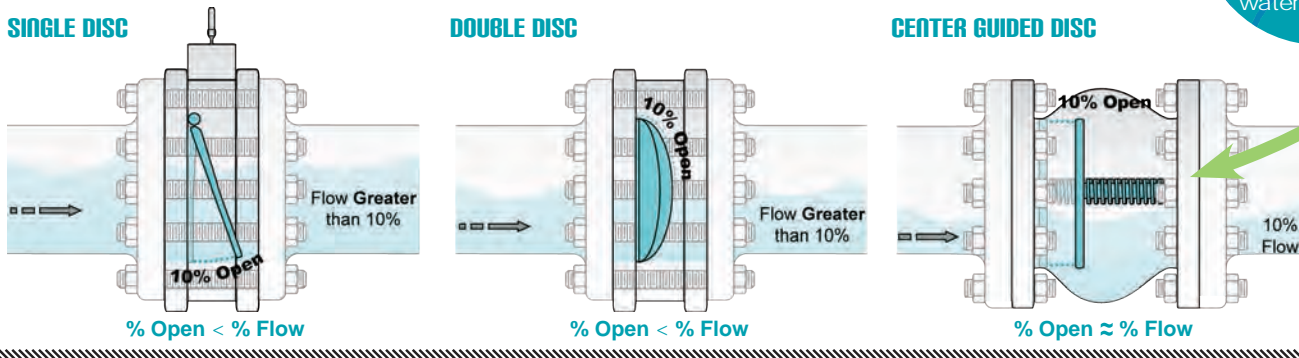

Head Loss

Head loss can be an important factor in check valve selection because energy loss in a pipeline can increase expenses significantly over time in certain applications. The main design features that affect head loss are the internal shape of the body and obstructions to the flow. Titan's Check Valves are designed with the following features to minimize head loss:

- **Large cross-sectional area** of center-guided check valves exceed that of the adjacent pipeline
- **Specially contoured bodies** on globe check valves are designed to allow a smooth flow across the valve
- **Short, straight flow paths** on double and single disk check valves prevent unnecessary head loss
- **Compression springs with a small boss** obstruct flow less than typical conical constructions by other manufacturer's
- **Low cracking pressure** on single and double disc check valves minimally slows the pipeline flow

RESILIENT / SOFT SEAT OPTIONS

BUNA-N

Max Temp: 250 °F

Buna-N is the most widely used elastomer. It works well for most petroleum oils and fluids, silicone greases and oils, and cold water. It also has an excellent compression set, tear, and abrasion resistance, but has poor weather resistance and moderate heat resistance. Buna-N is not recommended for ozone-resistant applications.

PTFE (TEFLON)

Max Temp: 425 °F

PTFE works well in most chemical environments. It has excellent tear, abrasive, chemical, acid, and alkali resistance. PTFE is not recommended for high pressure steam or large temperature variations.

VITON

Max Temp: 400 °F

Viton offers a broad range of chemical resistance and excellent heat resistance. Viton has good mechanical properties and compression set resistance, fair low temperature resistance, and limited hot-water resistance and shrinkage. Viton seats are often used in applications where nothing else will work.

EPDM

Max Temp: 300 °F

EPDM is likely the most water resistant rubber available. EPDM has good resistance to mild acids, alkalis, ketones, alcohols, and other polar solvents; however, it is not recommended for use with petroleum oils, di-ester lubricants, mineral oils, non-polar solvents, or aromatic fuels.

NEOPRENE

Max Temp: 250 °F

Neoprene is a durable & versatile synthetic rubber that was developed as an oil-resistant replacement for natural rubber. It is also resistant to the effects of moderate chemicals and acids, ozone, fats, greases, and solvents. It displays good chemical stability and is moderately resistant to heat. Neoprene is not recommended for use with strong oxidizing acids, esters, ketones, or chlorinated, aromatic and nitro hydrocarbons oils, non-polar solvents, or aromatic fuels.

TITAN FOOT VALVES

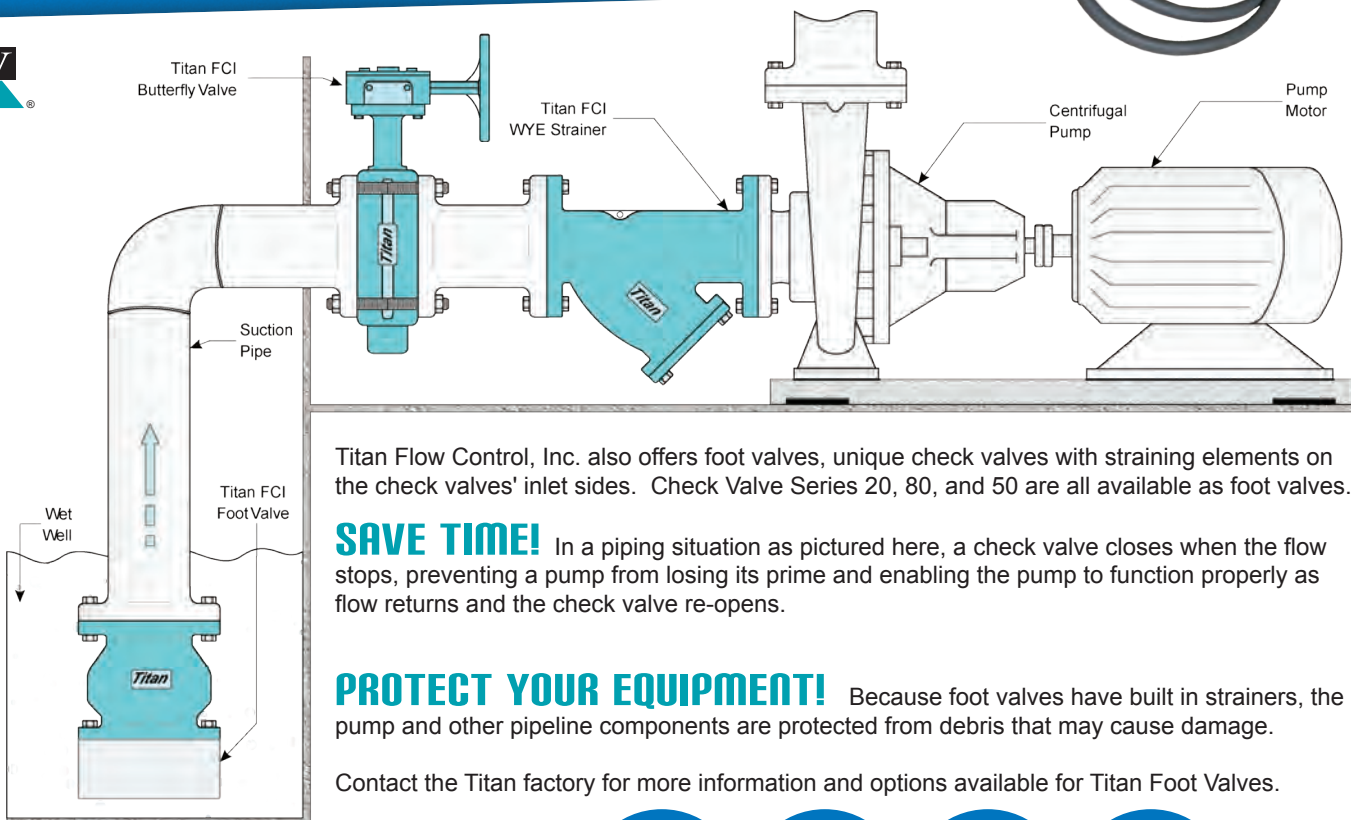

Titan Flow Control, Inc. also offers foot valves, unique check valves with straining elements on the check valves' inlet sides. Check Valve Series 20, 80, and 50 are all available as foot valves.

SAVE TIME! In a piping situation as pictured here, a check valve closes when the flow stops, preventing a pump from losing its prime and enabling the pump to function properly as flow returns and the check valve re-opens.

PROTECT YOUR EQUIPMENT! Because foot valves have built in strainers, the pump and other pipeline components are protected from debris that may cause damage.

Contact the Titan factory for more information and options available for Titan Foot Valves.

CALL
(910) 735-0000

FAX
(910) 738-3848

EMAIL
titan@titanfci.com

VISIT
www.titanfci.com

TITAN ORDERING CODES



Below are the typical ordering constructions for Titan Flow Control, Inc.'s **Dual Disc Check Valves, Center Guided Check Valves, and Single Disc Check Valves**. Please call Titan Flow Control or your nearest sales representative with any questions about Titan Check Valves related to ordering, availability, etc.

Dual Disc Check Valves

SERIES CV 42 - **BODY** CS - **DISC** S - **SHAFT** S - **SEAT** 1 - **SPRING** X

DESCRIPTION Dual Disc Wafer Type Check Valve (Class 150), Carbon Steel Body, Stainless Steel Disc, Stainless Steel Shaft, Buna Seat, and Inconel-X Spring

SERIES	CV 41 (ANSI 150)	CV 42 (ANSI 150)	CV 42L (ANSI 150)
	CV 44 (ANSI 300)	CV 46 (ANSI 600)	CV 47 (ANSI 900)
BODY	DI (Ductile Iron)	CS (Carbon Steel)	SS (Stainless Steel)
DISC	S (Stainless Steel)	B (Aluminum Bronze)	
SHAFT	S (Stainless Steel)		
SEAT	1 (Buna-N) 2 (EPDM)	3 (Viton) 4 (PTFE/Teflon)	5 (Neoprene) 6 (Metal to Metal, Stainless Steel)
SPRING	S (Stainless Steel)	R (Inconel)	X (Inconel-X)

Center Guided and Single Disc Valves

SERIES CV 91 - **BODY** SS - **DISC** S - **SEAT** 3

DESCRIPTION Wafer Type, Center Guided, Check Valve (Class 150/300) Stainless Steel Body, Stainless Steel Disc, Viton Seat

SERIES	CV 12 (ANSI 150)	CV 20 (WOG 400)	CV 90 (150 / 300)	CV 91 (150 / 300)
	CV 32 (ANSI 150)	CV 51 (ANSI 150)	CV 52 (ANSI 300)	
	CV 50 (ANSI 150)	CV 80 (ANSI 300)	CV 31 (ANSI 150)	
BODY	DI (Ductile Iron)	CS (Carbon Steel)	SS (Stainless Steel)	B (Bronze)
DISC	S (Stainless Steel) B (Aluminum Bronze)			
SEAT	1 (Buna-N)	2 (EPDM)	3 (Viton)	4 (PTFE/Teflon)
	S (Metal to Metal, Stainless Steel)			

CHECK OUT
TITAN'S
INVENTORY.
A WIDE SELECTION OF
CHECK VALVES ARE
ALWAYS **IN STOCK.**

Find a Titan
SALES REPRESENTATIVE
NEAR YOU: (910) 735-0000

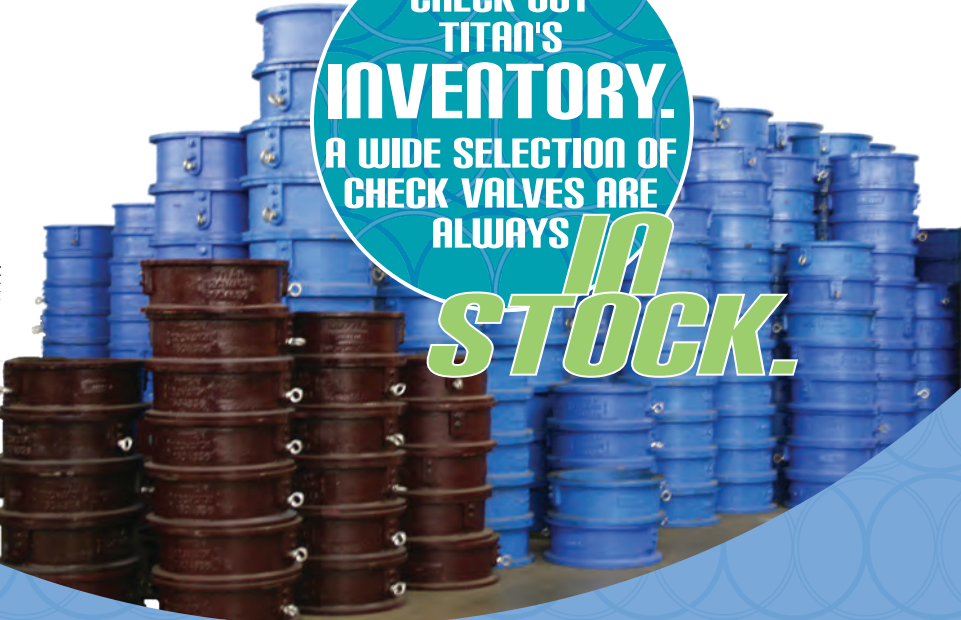

CALL
(910) 735-0000

FAX
(910) 738-3848

EMAIL
titan@titanfci.com

VISIT
www.titanfci.com



TITAN FLOW CONTROL, INC.

TECHNICAL AND PERFORMANCE DATA

PRESSURE DROP CHARTS ♦ CHECK VALVES

Style: Threaded Ends, Silent Check Valve

Model: CV 20-BZ (Bronze Unit)

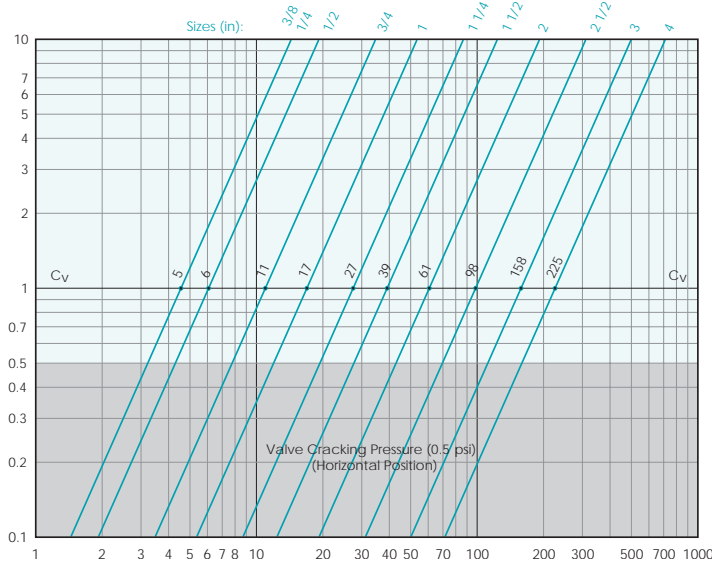

Legend: Pressure Drop - PSI (y - axis) versus Flow Rate - GPM (x - axis)

Style: Threaded Ends, Silent Check Valve

Model: CV 80-SS (Stainless Steel Unit)

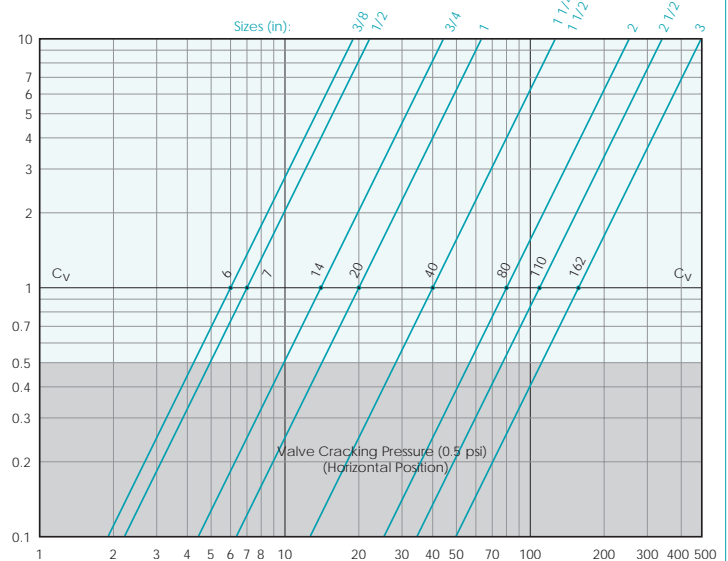

Legend: Pressure Drop - PSI (y - axis) versus Flow Rate - GPM (x - axis)

Style: Wafer Type, Single Disc Check Valve

Models: CV 31-DI, CV 32-CS/SS

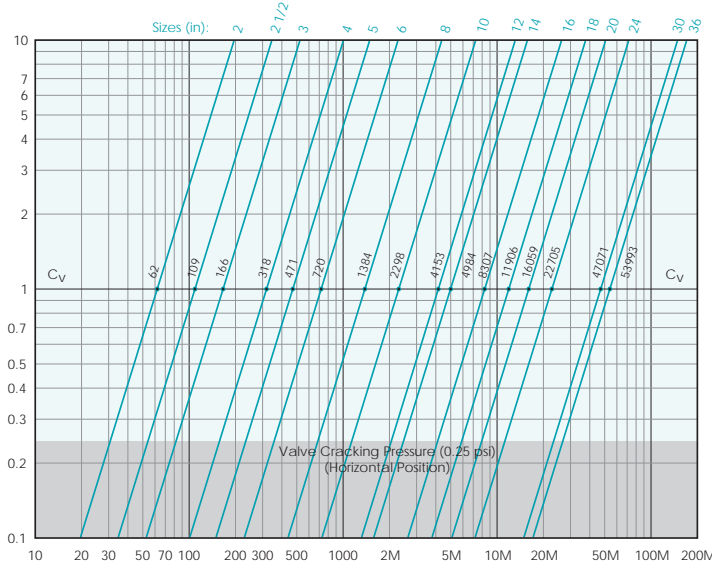

Legend: Pressure Drop - PSI (y - axis) versus Flow Rate - GPM (x - axis)

Style: Wafer Type, Short Pattern, Swing Check Valve

Models: CV 12-CS/SS

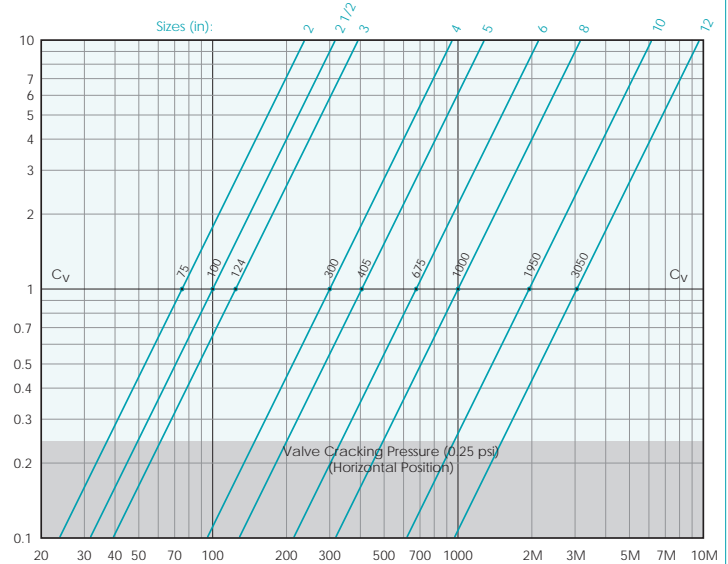

Legend: Pressure Drop - PSI (y - axis) versus Flow Rate - GPM (x - axis)

Pressure Drop Equation for Liquids:

$$\Delta P = G \times (Q / C_v)^2$$

ΔP = Pressure drop (psi)

C_v = Flow coefficient factor

G = Specific gravity of liquid at 60 °F

Q = Flow rate (GPM)

- These curves are theoretical; actual results may vary depending on installation conditions and other variables. Use these values for reference only.
- The above pressure drop charts are based upon 1/8" perforated screens and baskets handling clean water at 60 °F during ideal inlet and outlet conditions. Therefore, they should only be used for estimation purposes.
- For fluids other than water, multiply the pressure drop (ΔP) obtained from the charts by the specific gravity of the fluid in question.
- For mesh lined screens, multiply the pressure drop (ΔP) obtained from the charts by the corresponding correction factor shown in the C_v correction table.

TITAN FLOW CONTROL, INC.

Tel: 910-735-0000 ♦ Fax: 910-738-3848 ♦ titan@titanfci.com ♦ www.titanfci.com
290 Corporate Drive ♦ PO Box 7408 ♦ Lumberton, NC 28358



TITAN FLOW CONTROL, INC ❖ CHECK VALVE PRESSURE DROP CHARTS

Style: Wafer Type, Silent Check Valve

Models: CV 90-DB/DS, CV 91-SS

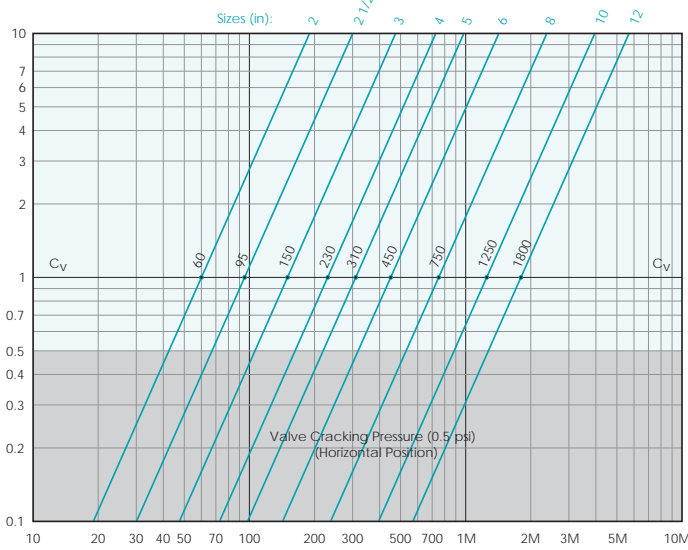

Style: Globe Type, Silent Check Valve

Models: CV 50-DI, CV 51-CS/SS, CV 52-DB/DS

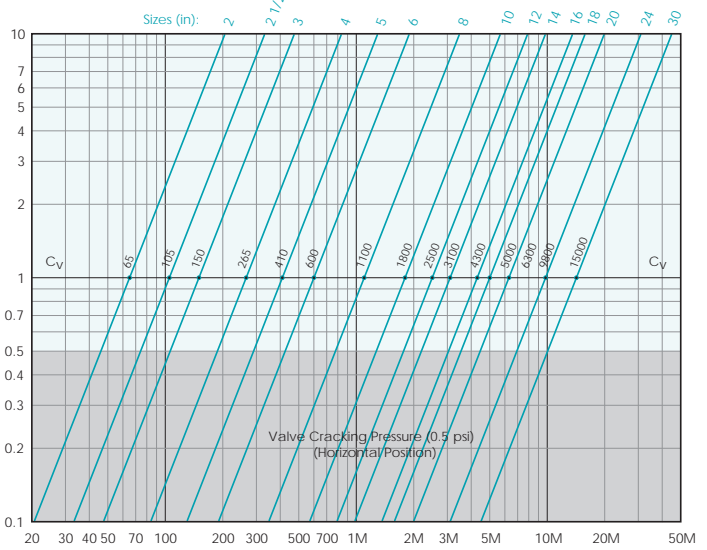

Style: Wafer Type, Double Disc Check Valve

Models: CV 41-DI, CV 42-CS/SS, CV 44-CS/SS

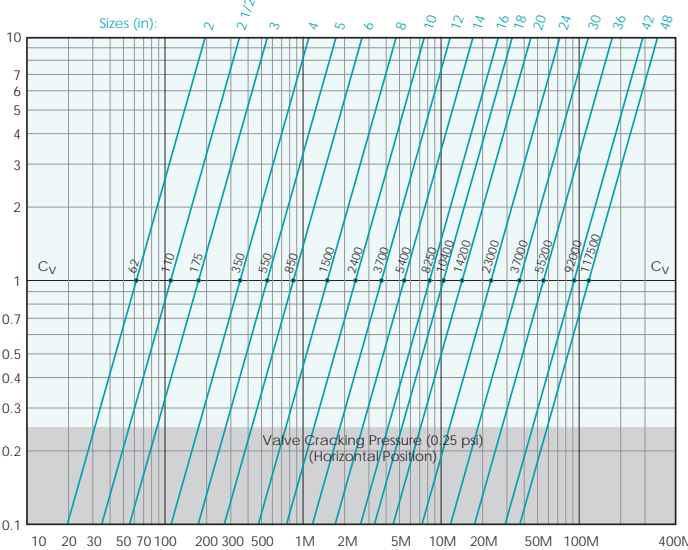

Style: Flanged, Control Check Valve (Tri-Flow)

Model: TF 21-CI (Disc in the full open position)

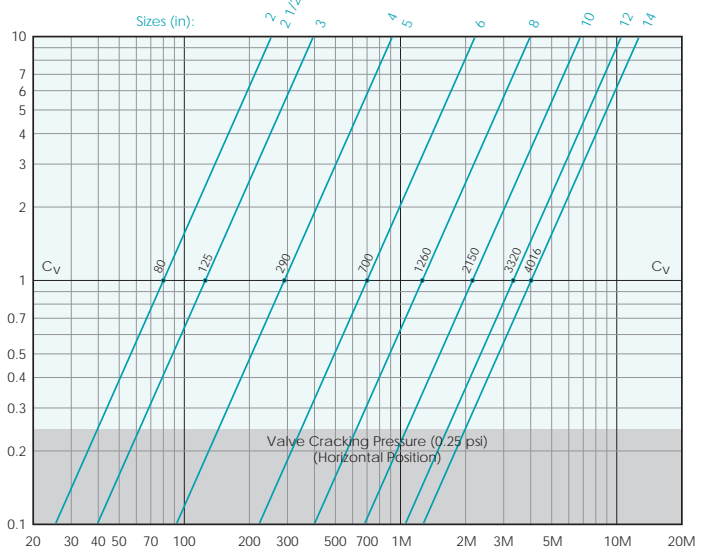

Style: High Pressure - Wafer Type, Double Disc CV

Model: CV 46-CS/SS

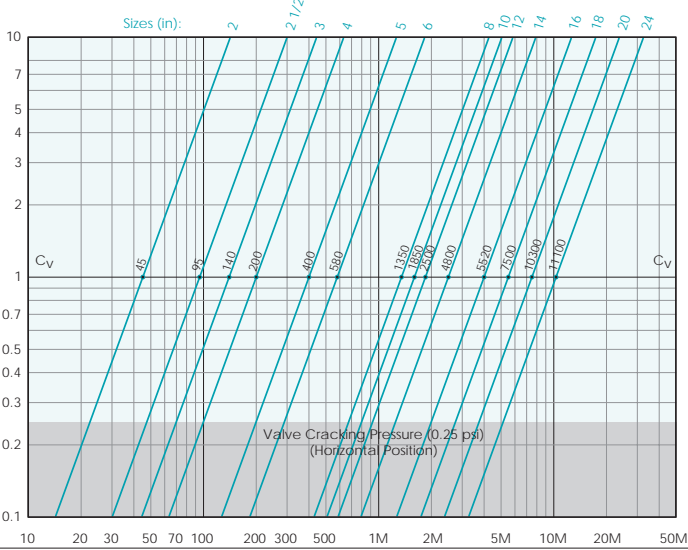

Style: High Pressure - Wafer Type, Double Disc CV

Model: CV 47-CS/SS

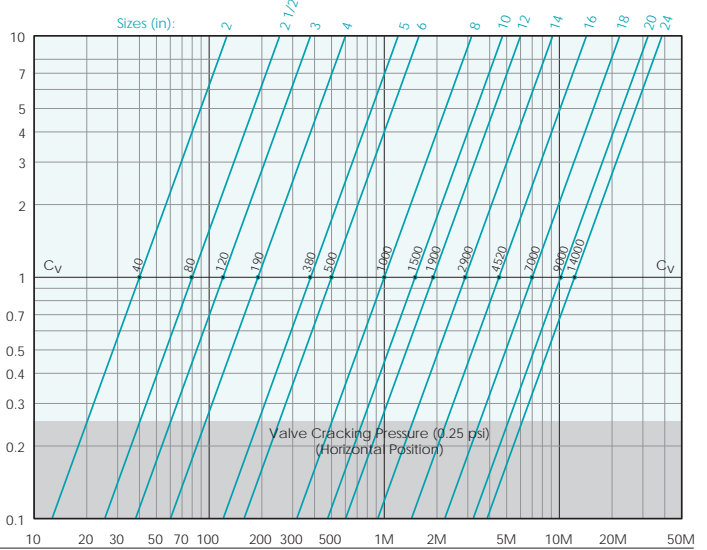

Legend: Pressure Drop - PSI (y - axis) versus Flow Rate - GPM (x - axis)



TITAN FLOW CONTROL, INC.

SILENT CHECK VALVE ♦ SINGLE DISC ♦ THREADED ENDS

400 WOG ♦ BRASS BODY ♦ BUNA-N SEAT

MODEL: CV 20-BR

BRASS BODY BUNA-N SEAT

FEATURES

- ♦ **QUICK CLOSURE TO REDUCE WATER HAMMER**
SILENT SHUT-OFF IS ACHIEVED VIA THE FULLY AUTOMATIC, SPRING ASSISTED DISC THAT CLOSES NEAR ZERO FLOW VELOCITY. THE LIGHTWEIGHT, CENTER GUIDED DISC DESIGN CREATES A POSITIVE SHUTOFF PRIOR TO FLOW REVERSAL AND HELPS TO KEEP SLAMMING AND SURGES TO A MINIMUM.
- ♦ **VERSATILE AND ECONOMICAL DESIGN**
CAN BE INSTALLED IN ANY POSITION (HORIZONTAL OR VERTICAL WITH UPWARD FLOW) - CONSULT FACTORY FOR VERTICAL WITH DOWNWARD FLOW. HEX ENDS ARE PROVIDED FOR QUICK AND EASY INSTALLATIONS.
- ♦ **BUBBLE TIGHT SEAL**
BY UTILIZING A BUNA-N SEAT AND A PATENTED DISC GUIDE, THE CV 20-BZ IN-LINE CHECK VALVE MAINTAINS A BUBBLE TIGHT SEAL THAT MEETS OR EXCEEDS API 598 LEAKAGE REQUIREMENTS.
- ♦ **MINIMAL HEAD LOSS**
THE CONTOUR OF BODY AND CHECK MODULE PROVIDE A FLOW PROFILE THAT GENERATES VERY LITTLE TURBULENCE. ADDITIONALLY, THE SPRING-LOADED, CENTER GUIDED DISC IS DESIGNED WITH LOW CRACKING PRESSURE WHICH REDUCES THE AMOUNT OF ENERGY REQUIRED TO OPEN THE VALVE.
- ♦ **DESIGNED FOR LONG SERVICE LIFE**
HIGHLY ADVANCED MATERIALS COUPLED WITH A PATENTED DISC DESIGN CAN PROVIDE A LONG SERVICE LIFE FOR A WIDE VARIETY OF APPLICATIONS.
- ♦ **NSF/ANSI STANDARD 61 CERTIFIED WITH BUNA-N SEAT**
APPROVED FOR USE IN DRINKING WATER SYSTEMS.

SIZE RANGE:
1/4" THROUGH 2"



TECHNICAL

PRESSURE/TEMPERATURE RATING BRASS CW 617N - UNI EN 12165
WOG (Non-shock): 400 PSI @ 100 °F Max Liquid: Consult Factory Max Steam: Not Recommended
SEAT MATERIAL MAXIMUM TEMPERATURE
Buna-N: 212 °F @ 170 PSI
SPRING MATERIAL MAXIMUM TEMPERATURE
Series 300 Stainless Steel: 400 °F
CHECK MODULE MATERIAL MAXIMUM TEMPERATURE
Polyetherimide: 365 °F

APPLICATIONS

MARKETS: OIL & GAS PRODUCTION, GENERAL INDUSTRY, CHEMICAL INDUSTRY, PETROCHEMICAL INDUSTRY, POWER, FOOD & BEVERAGE INDUSTRIES.

POLYETHERIMIDE: PEI IS A HIGH PERFORMANCE THERMOPLASTIC. IT PROVIDES HIGH STRENGTH AND RIGIDITY AT ELEVATED TEMPERATURES, LONG TERM HEAT RESISTANCE, AND OUTSTANDING DIMENSIONAL STABILITY. IT IS INHERENTLY FLAME RETARDANT. PEI CAN RESIST CHEMICALS SUCH AS HYDROCARBONS, ALCOHOLS AND HALOGENATED SOLVENTS.

BUNA-N PROPERTIES: MOST WIDELY USED ELASTOMER. GOOD FOR MOST PETROLEUM OILS AND FLUIDS, SILICONE GREASES AND OILS, AND COLD WATER. EXCELLENT COMPRESSION SET, TEAR, AND ABRASION RESISTANCE. POOR WEATHER RESISTANCE AND MODERATE HEAT RESISTANCE. NOT RECOMMENDED FOR SEVERE OZONE-RESISTANT APPLICATIONS.

The above data represents common market and service applications. No representation or guarantee, expressed or implied, is given due to the numerous variations of concentrations, temperatures and flow conditions that may occur during actual service.

TITAN FLOW CONTROL, INC.

YOUR PIPELINE TO THE FUTURE!

Tel: 910-735-0000 ♦ Fax: 910-738-3848 ♦ titan@titanfci.com ♦ www.titanfci.com
290 Corporate Drive ♦ PO Box 7408 ♦ Lumberton, NC 28358



TITAN FLOW CONTROL, Inc.
 290 Corporate Drive
 Lumberton, NC 28358
 Tel: 910.735.0000
 Fax: 910.738.3848

E-mail: titan@titanfci.com
 Web: www.titanfci.com

**IN-LINE • SILENT CHECK VALVE
 CENTER GUIDED • THREADED ENDS**

MODEL: CV 20-BR

Brass Body • BUNA-N Seat

1/4" ~ 2"
 400 WOG

BILL OF MATERIALS (1)

No.	PART	MATERIAL
1	BODY	Brass CW 617N
2	END CONNECTION	Brass CW 617N
3	CHECK MODULE	POLYETHERIMIDE
4	SEAT (2)	Buna-N
5	SPRING	Series 300 Stainless Steel

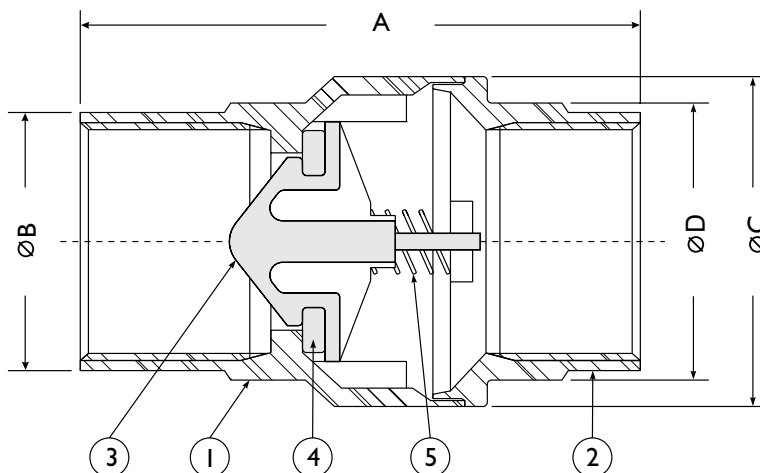

Notes:

1. Bill of Materials represents standard materials. Equivalent or better materials may be substituted at the manufacturer's discretion.
2. Denotes recommended spare parts.

DIMENSIONS AND PERFORMANCE DATA (1)

SIZE	in	1/4	3/8	1/2	3/4	1	1 1/4	1 1/2	2
	mm	8	10	15	20	25	32	40	50
A DIMENSION FACE TO FACE	in	2.32	2.32	2.32	2.56	2.76	2.93	3.17	3.37
	mm	59	59	59	66	71	75	81	86
ØB DIMENSION END DIAMETER	in	.98	.98	.98	1.20	1.48	1.87	2.10	2.68
	mm	25	25	25	31	38	48	54	69
ØC DIMENSION BODY DIAMETER	in	1.35	1.35	1.35	1.65	1.92	2.40	2.87	3.46
	mm	35	35	35	42	49	61	73	88
ØD DIMENSION OCTAGONAL ENDS	in	.98	.98	.98	1.22	1.50	1.89	2.12	2.64
	mm	25	25	25	31	39	49	54	68
ASSEMBLED WEIGHT	lb	.22	.37	.32	.49	.68	1.13	1.61	2.28
	kg	.1	.2	.1	.2	.3	.5	.7	1.0
Flow Coefficient	C _v	4.55	4.55	6.07	10.97	16.92	27.42	39.09	60.68
Cracking Pressure (2)	psi	≤ .5	≤ .5	≤ .5	≤ .5	≤ .5	≤ .5	≤ .5	≤ .5

Additional Notes:

1. End connection is female to female per ANSI B 1.20.1.
2. Perfect sealing both at high and low pressures with wide temperature range: +10 ~ 210 °F
3. Low cracking pressure, approximately 1/2 PSI.
4. Low profile designed to minimize head loss.
5. High technology materials to ensure best resistance in any condition.

1. Dimensions, weights, and flow coefficients are provided for reference only. When required, always request certified drawings.
2. This listed valve cracking pressure only applies to horizontal installations. For vertical installations, cracking pressure is higher. Please consult factory.

PRESSURE-TEMPERATURE RATINGS - CV 20-BR

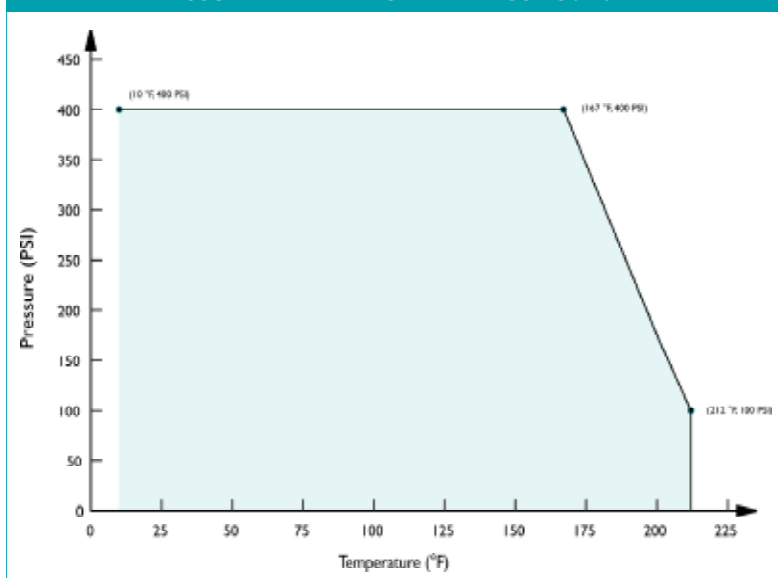

REFERENCED STANDARDS & CODES

CODE	DESCRIPTION
ANSI B1.1	Unified Inch Screw Threads
ANSI B1.20.1	Pipe Threads - General Purpose
ANSI B16.15	Cast Bronze Threaded Fittings

PRESSURE - TEMPERATURE RATING

Body Material - BRASS CW 617N - UNI EN 12165 - 400 WOG
 WOG (Non-shock): 400 PSI @ 100 °F
 Max Liquid: Consult Factory
 Max Steam: Not Recommended

SEAT TEMPERATURE RATING

Seat Material	Maximum Temperature
Buna-N:	212 °F @ 170 PSI

SPRING TEMPERATURE RATING

Spring Material	Maximum Temperature
Series 300 Stainless Steel:	400 °F

CHECK MODULE TEMPERATURE RATING

Check Module Material	Maximum Temperature
Polyetherimide:	365 °F

Titan FCI makes every effort to ensure the information presented on our literature accurately reflects exact product specifications. However, as product changes occur, there may be short-term differences between actual product specifications and the information contained within our literature. Titan FCI reserves the right to make design and specification changes to improve our products without prior notification. When required, request certified drawings.



TITAN FLOW CONTROL, INC.

SILENT CHECK VALVE ♦ SINGLE DISC ♦ THREADED ENDS

ANSI CLASS 300 ♦ STAINLESS STEEL BODY

MODEL: CV 80-SS

STAINLESS STEEL BODY
VITON SEAT

FEATURES

- ♦ **QUICK CLOSURE TO REDUCE WATER HAMMER**
SILENT SHUT-OFF IS ACHIEVED VIA THE FULLY AUTOMATIC, SPRING ASSISTED DISC THAT CLOSES NEAR ZERO FLOW VELOCITY. THE LIGHTWEIGHT, CENTER GUIDED DISC DESIGN CREATES A POSITIVE SHUTOFF PRIOR TO FLOW REVERSAL AND HELPS TO KEEP SLAMMING AND SURGES TO A MINIMUM.
- ♦ **MINIMAL HEAD LOSS**
THE CONTOUR OF BODY PROVIDES A SHORT AND STRAIGHT FLOW PATH THAT GENERATES VERY LITTLE TURBULENCE. ADDITIONALLY, THE SPRING-LOADED, CENTER GUIDED DISC IS DESIGNED WITH VERY LOW CRACKING PRESSURE WHICH REDUCES THE AMOUNT OF ENERGY REQUIRED TO OPEN THE VALVE.
- ♦ **BUBBLE TIGHT SEAL**
BY UTILIZING A TEFLON SEAT AND GASKET IN CONJUNCTION WITH PRECISION MACHINED SEALING SURFACES, THE CV 80-SS MAINTAINS A BUBBLE TIGHT SEAL THAT MEETS OR EXCEEDS API 598 LEAKAGE REQUIREMENTS.
- ♦ **DESIGNED FOR LONG SERVICE LIFE**
THE CV 80-SS UTILIZES A HIGHLY RELIABLE INVESTMENT CASTING, STAINLESS STEEL CONSTRUCTION, AND A SIMPLIFIED DESIGN (ONLY SIX PARTS) THAT CAN PROVIDE A LONG SERVICE LIFE FOR A WIDE VARIETY OF APPLICATIONS.
- ♦ **VERSATILE AND ECONOMICAL DESIGN**
THE CV 80-SS CAN BE INSTALLED IN ANY POSITION (HORIZONTAL OR VERTICAL WITH UPWARD FLOW) - CONSULT FACTORY FOR VERTICAL WITH DOWNWARD FLOW. HEX ENDS ARE PROVIDED FOR QUICK AND EASY INSTALLATIONS

SIZE RANGE:
3/8" THROUGH 3"



TECHNICAL

PRESSURE/TEMPERATURE RATING SS - ASTM A351 GR. CF8M - CLASS 300
WOG (Non-shock): 720 PSI @ 100 °F Max Liquid: Consult Factory Max Steam: Not Recommended
SEAT MATERIAL TEMPERATURE RANGE
Viton: - 4 ~ 392 °F PTFE: - 2 ~ 248 °F
SPRING MATERIAL MAXIMUM TEMPERATURE
Type 316 SS: 450 °F

APPLICATIONS

MARKETS: OIL & GAS PRODUCTION, GENERAL INDUSTRY, CHEMICAL INDUSTRY, PETROCHEMICAL INDUSTRY, POWER, FOOD & BEVERAGE INDUSTRIES.

SERVICE: CHEMICAL / STEAM / NITROGEN LINES, GAS INJECTION, CONDENSATE RECOVERY, PUMP & COMPRESSOR DISCHARGE, PUMP JACK FLOW LINES, CHILLER & BOILER FEED

VITON PROPERTIES: OFFERS A BROAD RANGE OF CHEMICAL RESISTANCE AND EXCELLENT HEAT RESISTANCE. GOOD MECHANICAL PROPERTIES AND COMPRESSION SET RESISTANCE. OFTEN USED IN APPLICATIONS WHERE NOTHING ELSE WILL WORK. FAIR LOW TEMPERATURE RESISTANCE AND LIMITED HOT-WATER RESISTANCE AND SHRINKAGE.

The above data represents common market and service applications. No representation or guarantee, expressed or implied, is given due to the numerous variations of concentrations, temperatures and flow conditions that may occur during actual service.

TITAN FLOW CONTROL, INC.

YOUR PIPELINE TO THE FUTURE!

Tel: 910-735-0000 ♦ Fax: 910-738-3848 ♦ titan@titanfci.com ♦ www.titanfci.com
290 Corporate Drive ♦ PO Box 7408 ♦ Lumberton, NC 28358



TITAN FLOW CONTROL, Inc.
 290 Corporate Drive
 Lumberton, NC 28358
 Tel: 910.735.0000
 Fax: 910.738.3848
 E-mail: titan@titanfci.com
 Web: www.titanfci.com

IN-LINE • SILENT CHECK VALVE
CENTER GUIDED • THREADED ENDS
MODEL: CV 80-SS

ANSI Class
 300

Stainless Steel Body • PTFE Seat and Gasket

BILL OF MATERIALS (1)

No.	PART	MATERIAL
1	CAP	ASTM A351 Gr. CF8M Stainless Steel
2	DISC	Stainless Steel 18-8
3	STEM	ASTM A351 Gr. CF8M Stainless Steel
4	GASKET (2)	PTFE
5	SEAT	Viton/PTFE
6	SPRING	Type 316 Stainless Steel
7	BODY	ASTM A351 Gr. CF8M Stainless Steel

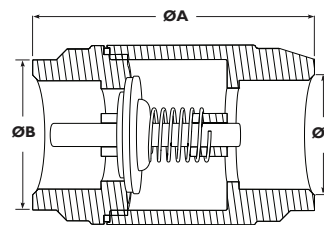
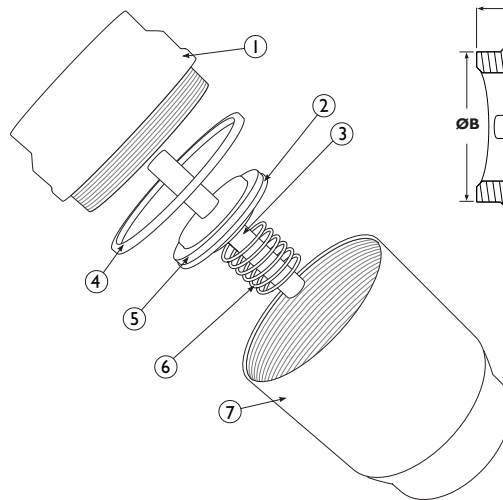

Design Notes:

1. Size range: 3/8" ~ 3"
2. ANSI Class 300
3. Low cracking pressure
4. Minimal head loss
5. Low pressure drop
6. Spring assisted design
7. Long stem for smooth closure
8. Viton Seat for long service life

Notes:

1. Bill of Materials represents standard materials. Equivalent materials may be substituted at the manufacturer's discretion.
2. Denotes recommended spare parts.
3. Viton seats are standard. PTFE seats are available in limited quantities. Consult Factory.

DIMENSIONS AND PERFORMANCE DATA (1)

SIZE	in	3/8	1/2	3/4	1	1 1/4	1 1/2	2	2 1/2	3
	mm	10	15	20	25	32	40	50	65	80
A DIMENSION FACE TO FACE	in	2.086	2.204	2.480	2.913	3.188	3.582	3.818	4.660	5.500
	mm	53	56	63	74	81	91	97	118	140
ØB DIMENSION OUTSIDE DIAMETER	in	0.905	1.181	1.620	1.878	2.165	2.775	3.228	4.312	4.900
	mm	23	30	41	48	55	70	82	110	125
ØC DIMENSION INSIDE DIAMETER	in	0.669	.826	1.023	1.259	1.614	1.850	2.322	2.625	3.250
	mm	17	21	26	32	41	47	59	67	83
ASSEMBLED WEIGHT	lb	0.3	0.4	0.5	1.0	1.5	2.5	3.5	6.0	8.5
	kg	0.1	0.2	0.2	0.5	0.7	1.1	1.6	2.7	3.9
Flow Coefficient	C _v	6	7	14	20	40	40	80	110	162
Cracking Pressure (2)	psi	≤ .5	≤ .5	≤ .5	≤ .5	≤ .5	≤ .5	≤ .5	≤ .5	≤ .5

1. Dimensions, weights, and flow coefficients are provided for reference only. When required, always request certified drawings.
2. The listed valve cracking pressure only applies to horizontal installations. For vertical installations, cracking pressure is higher. Please consult factory.

PRESSURE-TEMPERATURE RATINGS FOR CF8M (1) CLASS 300

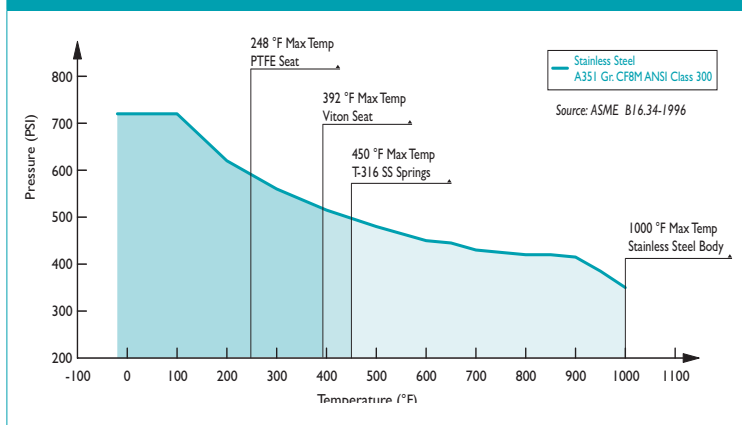

1. The above chart displays the pressure-temperature ratings for the valve's body material per ASME/ANSI B16.34-1996. For reference, maximum temperature limits have been added for seat and spring materials. PTFE seat limits the maximum temperature for this valve. Stainless Steel not recommended for prolonged use above 1000 °F

REFERENCED STANDARDS & CODES

CODE	DESCRIPTION
ANSI B1.1	Unified Inch Screw Threads
ANSI B1.20.1	Pipe Threads - General Purpose
ANSI B16.34	Valves - Flanged, Threaded & Welding Ends
ASTM A351 GR CF8M	Austenitic Steel Castings

PRESSURE - TEMPERATURE RATING

Body Material - ASTM A351 GR. CF8M - CLASS 300

WOG (Non-shock): 720 PSI @ 100 °F

Max Liquid: Consult Factory

Max Steam: Not Recommended

SEAT AND GASKET TEMPERATURE RATING

Seat Material	Temperature Range
Viton:	- 4 ~ 392 °F
Teflon (PTFE):	- 2 ~ 248 °F

SPRING TEMPERATURE RATING

Spring Material	Maximum Temperature
T-316 Stainless Steel	450 °F

Titan FCI makes every effort to ensure the information presented on our literature accurately reflects exact product specifications. However, as product changes occur, there may be short-term differences between actual product specifications and the information contained within our literature. Titan FCI reserves the right to make design and specification changes to improve our products without prior notification. When required, request certified drawings.



TITAN FLOW CONTROL, INC.

SILENT CHECK VALVE ♦ WAFER TYPE ♦ CENTER GUIDED

ANSI CLASS 150/300 (125/250) ♦ DUCTILE IRON BODY

MODEL: CV 90-DI

Body: Ductile Iron
Trims: Stainless Steel
or Bronze
Seats: Buna and Viton

PATENT-PENDING
DESIGN WITH INTEGRAL
STRAIGHTENING
VANES

Size Range: 2" ~ 12"

Sizes 2" ~ 6" provide Dual
Pressure Service
ANSI Class 150/300

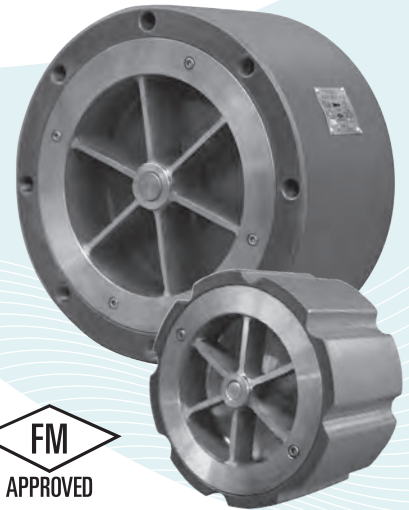

FEATURES

- ◇ **DESIGNED FOR LONG SERVICE LIFE**
NEWLY DESIGNED CV90'S HAVE STRAIGHTENING VANES THAT REDUCE TURBULENCE IN INCOMING FLOW, THUS MINIMIZING NOISE, VIBRATIONS, EROSION, CAVITATIONS, AND OTHER FACTORS THAT COULD RESULT IN PREMATURE VALVE FAILURE.
- ◇ **MINIMAL HEAD LOSS**
HEAD LOSS IS MINIMIZED BY PROVIDING A LARGE CROSS-SECTIONAL AREA WHICH EXCEEDS THAT OF THE ADJACENT PIPELINE. ADDITIONALLY, THE SPRING-LOADED, CENTER GUIDED DISC IS DESIGNED WITH VERY LOW CRACKING PRESSURE WHICH REDUCES THE AMOUNT OF ENERGY REQUIRED TO OPEN THE VALVE.
- ◇ **QUICK CLOSURE TO REDUCE WATER HAMMER**
SILENT SHUT-OFF IS ACHIEVED VIA THE FULLY AUTOMATIC, SPRING ASSISTED DISC THAT CLOSURES NEAR ZERO FLOW VELOCITY. THE LIGHTWEIGHT, CENTER GUIDED DISC DESIGN CREATES A POSITIVE SHUTOFF PRIOR TO FLOW REVERSAL AND HELPS TO KEEP SLAMMING AND SURGES TO A MINIMUM.
- ◇ **RESILIENT SOFT SEATS**
SOFT SEATS (BUNA & VITON) COMBINED WITH PRECISION MACHINED SEALING SURFACES ALLOW THE CV 90-DI TO MAINTAIN A BUBBLE SEAL THAT MEETS API 598 LEAKAGE REQUIREMENTS. METAL SEATS CAN ALSO BE FURNISHED.
- ◇ **VERSATILE DESIGN**
SIZES 2" THROUGH 6" UTILIZE A UNIQUE SCALLOP DESIGN THAT PERMITS DUAL PRESSURE SERVICE (ANSI CLASS 150 AND 300). SIZES 8" THROUGH 12" ARE ONLY RATED FOR ANSI CLASS 150.

TECHNICAL

PRESSURE/TEMPERATURE RATING ⁽¹⁾ DUCTILE IRON - ASTM A536 - CLASS 150
WOG (Non-shock): 250 PSI @ 100 °F (2" ~ 12")
PRESSURE/TEMPERATURE RATING ⁽¹⁾ DUCTILE IRON - ASTM A536 - CLASS 300
WOG (Non-shock): 640 PSI @ 100 °F (2" ~ 6")
SEAT MATERIAL (O-RING) ⁽¹⁾ TEMPERATURE RANGE
BUNA-N: -20 ~ 250 °F VITON: -40 ~ 400 °F
SPRING MATERIAL ⁽¹⁾ MAXIMUM TEMPERATURE
STAINLESS STEEL: 450 °F

1. The above listed temperatures are theoretical and may vary during actual operating conditions.

APPLICATIONS

MARKETS: OIL AND GAS PRODUCTION, GENERAL INDUSTRY, CHEMICAL, PETROCHEMICAL, POWER, FOOD AND BEVERAGE

SERVICE: PUMP DISCHARGE SERVICE IN MUNICIPAL WATER, IRRIGATION, AND INDUSTRIAL CLASS HVAC SYSTEMS. IT IS RECOMMENDED THAT A TITAN FCI STRAINER BE INSTALLED AHEAD OF THE PUMP TO ENSURE PROTECTION OF THE CHECK VALVE AND THE PUMP.

PRECAUTIONS: THIS VALVE IS INTENDED FOR LIQUID SERVICE THAT DOES NOT EXCEED 10 FT/SEC. IT IS DESIGNED FOR STEADY FLOW CONDITIONS AND IS NOT RECOMMENDED FOR USE IN RECIPROCATING PUMP, COMPRESSOR OR OTHER TYPE OF PHYSICAL/THERMAL SHOCK-LOAD APPLICATIONS. THIS VALVE IS NOT RECOMMENDED FOR STEAM SERVICE OR FLOW MEDIA THAT CONTAINS SOLIDS. IT SHOULD BE INSTALLED AT LEAST FIVE PIPE DIAMETERS DOWNSTREAM FROM ANY TURBULENCE PRODUCING COMPONENTS. FLOW STRAIGHTENERS MAY BE REQUIRED IN CERTAIN APPLICATIONS.

The above data represents common market and service applications. No representation or guarantee, expressed or implied, is given due to the numerous variations of concentrations, temperatures and flow conditions that may occur during actual service.

TITAN FLOW CONTROL, INC.
YOUR PIPELINE TO THE FUTURE!

Tel: 910-735-0000 ♦ Fax: 910-738-3848 ♦ titan@titanfci.com ♦ www.titanfci.com
290 Corporate Drive ♦ PO Box 7408 ♦ Lumberton, NC 28358



TITAN FLOW CONTROL, Inc.
 290 Corporate Drive
 Lumberton, NC 28358
 Tel: 910.735.0000
 E-mail: titan@titanfci.com
 Web: www.titanfci.com
 Fax: 910.738.3848

**SILENT CHECK VALVE • WAFER TYPE
 CENTER GUIDED DESIGN • DUCTILE IRON
 MODEL: CV 90-DI - Ductile Iron Body**

**ANSI
 Class
 150/300
 (125/250)**

BILL OF MATERIALS (1)

No.	PART	CV 90-DI-B-1
1	Body (2)	Ductile Iron ASTM A536
2	Seat (3) (4)	Aluminum Bronze with Buna-N O-ring
3	Disc	ASTM B148 Aluminum Bronze
4	Spring (4)	Series 300 Stainless Steel
5	Bushing (4)	Bronze ASTM B584 Aluminum Bronze
6	Screws (4)	ASTM A276 Type 304 Stainless Steel

No.	PART	CV 90-DI-S-3
1	Body (2)	Ductile Iron ASTM A536
2	Seat (3) (4)	Stainless Steel with Viton O-ring
3	Disc	ASTM A351 Gr. CF8M Type 316 Stainless Steel
4	Spring (4)	Series 300 Stainless Steel
5	Bushing (4)	ASTM A351 Gr. CF8M Type 316 Stainless Steel
6	Screws (4)	ASTM A276 Type 304 Stainless Steel

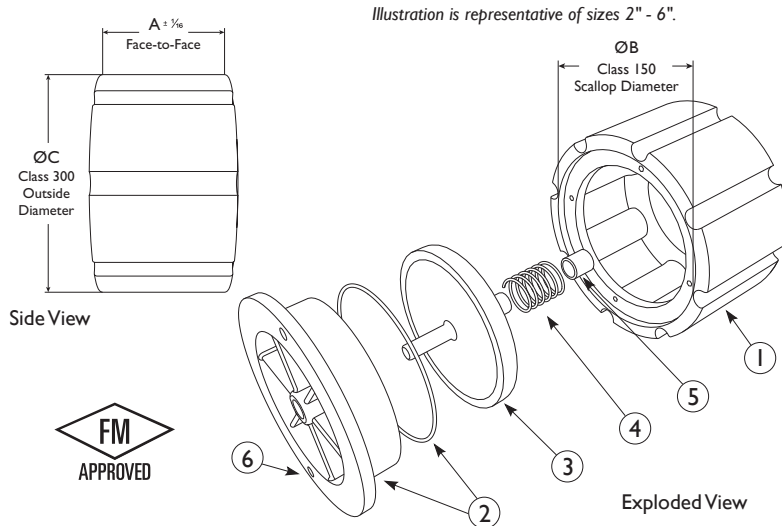

- BOM represents standard materials. Equivalent or better materials may be substituted at the manufacturer's discretion.
- Bodies are epoxy painted.
- Metal seats also available.
- Denotes recommended spare parts.

Additional Design & Technical Notes:

Sizes 2" through 6" utilize a unique scallop design that permits dual pressure service (150/300 lb). These sizes fit properly between any Cast Iron ANSI Class 125/250 or Ductile Iron ANSI Class 150/300 flanges. Sizes 8" through 12" are only rated for ANSI Class 150 service. The bolting pattern for Cast Iron Class 125/250 and Ductile Iron Class 150/300 are the same, respectively.

Ductile Iron check valves offer higher pressure ratings than Cast Iron check valves. For example, Ductile Iron check valves (2" ~ 24") are rated at 640 psi wog where as Cast Iron check valves (2" ~ 12") are rated at 500 psi wog and (14" ~ 24") are only rated at 300 psi wog.

DIMENSIONS AND PERFORMANCE DATA (1)

SIZE	in	2	2 1/2	3	4	5	6	8 (2)	10 (2)	12 (2)
	mm	50	65	80	100	125	150	200	250	300
A DIMENSION FACET TO FACE	in	2.62	2.87	3.12	4.0	4.62	5.62	6.50	8.25	11.25
	mm	67	73	79	102	117	143	165	210	286
ØB DIMENSION SCALLOP DIAMETER 150 lb (2" THROUGH 12")	in	4.0	4.75	5.25	6.75	7.62	8.62	n/a	n/a	n/a
	mm	102	121	133	171	194	219	276	n/a	n/a
ØC DIMENSION OUTSIDE DIAMETER 300 lb (2" THROUGH 6")	in	4.25	5.0	5.75	7.0	8.37	9.75	n/a	n/a	n/a
	mm	108	127	146	178	213	248	n/a	n/a	n/a
ASSEMBLED WEIGHT	lb	4.5	7.0	9.5	17.5	25.5	38.0	88.0	162.0	300.5
	kg	2.0	3.2	4.3	7.9	11.6	17.2	39.9	73.4	136.2
Flow Coefficient	C _v	60	95	150	230	310	450	750	1250	1800
Cracking Pressure (3)	psi	≤ .5	≤ .5	≤ .5	≤ .5	≤ .5	≤ .5	≤ .5	≤ .5	≤ .5

- Dimensions, weights, and flow coefficients are provided for reference only. When required, always request certified drawings.
- Sizes 8", 10" and 12" are not scalloped, but tapping for cap screws is provided. Contact factory for diameter dimension if needed.
- Cracking pressure is for horizontal installations only. For vertical installations, please consult factory.

PRESSURE-TEMPERATURE RATINGS (1)

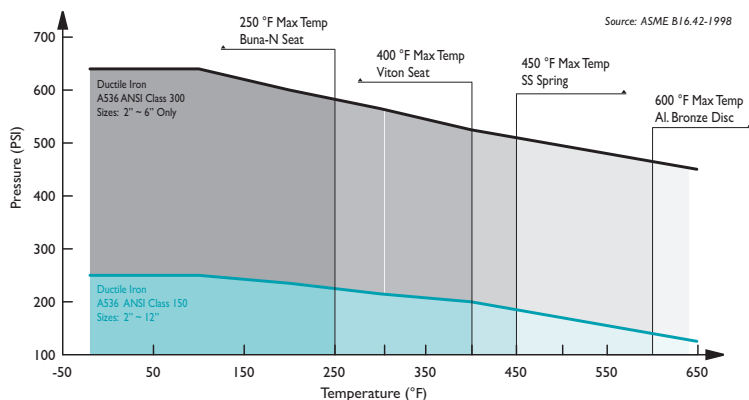

- This chart displays the pressure-temperature ratings for the valve's body per ASME B1.6.42-1998. Maximum temperature limits have been added for seat and spring materials.

REFERENCED STANDARDS & CODES

CODE	DESCRIPTION
ANSI B16.42	Ductile Iron Pipe Flanges and Flanged Fittings
ANSI B16.5	Pipe Flanges and Flanged Fittings
MSS SP-6	Standards Finishes for Connecting-end Flanges
MSS SP-25	Standard Marking System for Valves
MSS SP-125	D.I., In-Line, Spring Loaded, Center-Guided Valves
FM APPROVALS CLASS 1230	Anti-Water Hammer Check Valves (2" ~ 12")

PRESSURE/TEMPERATURE RATING (1)

ANSI Class	150 lb Service 2" ~ 12"	300 lb Service 2" ~ 6" only
WOG (Non-shock)	250 PSI @ 100 °F	640 PSI @ 100 °F

SEAT AND SPRING TEMPERATURE RATINGS (1)

SEAT (O-Ring)	Temperature Range
Buna-N	-20 °F @ 250 °F
Viton	-40 °F ~ 400 °F
SPRING	Maximum Temperature
Stainless Steel	450 °F

- The listed pressure and temperature ratings for the valve's body, seat, and spring are theoretical and may vary during actual operating conditions.

Titan FCI makes every effort to ensure the information presented on our literature accurately reflects exact product specifications. However, as product changes occur, there may be short-term differences between actual product specifications and the information contained within our literature. Titan FCI reserves the right to make design and specification changes to improve our products without prior notification. When required, request certified drawings.

ORDERING CODE

Model Number	Description
CV90-DI-B-1	Ductile Iron Body, Bronze Seat and Disc, Buna-N Seat
CV90-DI-S-3	Ductile Iron Body, Stainless Steel Seat and Disc, Viton Seat



TITAN FLOW CONTROL, INC.

SILENT CHECK VALVE ♦ WAFER TYPE ♦ CENTER GUIDED

ANSI CLASS 150/300 ♦ STAINLESS STEEL BODY

MODEL: CV 91-SS

Body: Stainless Steel
Trim : Stainless Steel
Seats: Stainless Steel

PATENT-PENDING
DESIGN WITH INTEGRAL
STRAIGHTENING
VANES



Size Range: 2" ~ 12"

Sizes 2" ~ 6" provide Dual Pressure Service
ANSI Class 150/300

FEATURES

- ◇ **DESIGNED FOR LONG SERVICE LIFE**
NEWLY DESIGNED CV91'S HAVE STRAIGHTENING VANES THAT REDUCE TURBULENCE IN INCOMING FLOW, THUS MINIMIZING NOISE, VIBRATIONS, EROSION, CAVITATIONS, AND OTHER FACTORS THAT COULD RESULT IN PREMATURE VALVE FAILURE.
- ◇ **MINIMAL HEAD LOSS**
HEAD LOSS IS MINIMIZED BY PROVIDING A LARGE CROSS-SECTIONAL AREA WHICH EXCEEDS THAT OF THE ADJACENT PIPELINE. ADDITIONALLY, THE SPRING-LOADED, CENTER GUIDED DISC IS DESIGNED WITH VERY LOW CRACKING PRESSURE WHICH REDUCES THE AMOUNT OF ENERGY REQUIRED TO OPEN THE VALVE.
- ◇ **QUICK CLOSURE TO REDUCE WATER HAMMER**
SILENT SHUT-OFF IS ACHIEVED VIA THE FULLY AUTOMATIC, SPRING ASSISTED DISC THAT CLOSES NEAR ZERO FLOW VELOCITY. THE LIGHTWEIGHT, CENTER GUIDED DISC DESIGN CREATES A POSITIVE SHUTOFF PRIOR TO FLOW REVERSAL AND HELPS TO KEEP SLAMMING AND SURGES TO A MINIMUM.
- ◇ **METAL-TO-METAL SEATS**
PRECISION MACHINED SEALING SURFACES ALLOW THE CV 91-SS TO MAINTAIN A TIGHT SEAL THAT MEETS OR EXCEEDS API 598 LEAKAGE REQUIREMENTS. RESILIENT SEATS CAN ALSO BE FURNISHED. PLEASE CONTACT FACTORY.
- ◇ **VERSATILE DESIGN**
SIZES 2" THROUGH 6" UTILIZE A UNIQUE SCALLOP DESIGN THAT PERMITS DUAL PRESSURE SERVICE (ANSI CLASS 150 AND 300). SIZES 8" THROUGH 12" ARE ONLY RATED FOR ANSI CLASS 150.

TECHNICAL

PRESSURE/TEMPERATURE RATING ⁽¹⁾ STAINLESS STEEL - ASTM A351 Gr. CF8M- CLASS 150
WOG (Non-shock): 275 PSI @ 100 °F (2" ~ 12")
PRESSURE/TEMPERATURE RATING ⁽¹⁾ STAINLESS STEEL - ASTM A351 Gr. CF8M- CLASS 300
WOG (Non-shock): 720 PSI @ 100 °F (2" ~ 6")
SEAT MATERIAL ⁽¹⁾ TEMPERATURE RANGE
STAINLESS STEEL: -325 ~ 1500 °F
SPRING MATERIAL ⁽¹⁾ MAXIMUM TEMPERATURE
STAINLESS STEEL: 450 °F

1. The above listed temperatures are theoretical and may vary during actual operating conditions.

APPLICATIONS

MARKETS: OIL AND GAS PRODUCTION, GENERAL INDUSTRY, CHEMICAL, PETROCHEMICAL, POWER, FOOD AND BEVERAGE

SERVICE: PUMP DISCHARGE SERVICE IN MUNICIPAL WATER, IRRIGATION, AND INDUSTRIAL CLASS HVAC SYSTEMS. IT IS RECOMMENDED THAT A TITAN FCI STRAINER BE INSTALLED AHEAD OF THE PUMP TO ENSURE PROTECTION OF THE CHECK VALVE AND THE PUMP.

PRECAUTIONS: THIS VALVE IS INTENDED FOR LIQUID SERVICE THAT DOES NOT EXCEED 10 FT/SEC. IT IS DESIGNED FOR STEADY FLOW CONDITIONS AND IS NOT RECOMMENDED FOR USE IN RECIPROCATING PUMP, COMPRESSOR OR OTHER TYPE OF PHYSICAL/THERMAL SHOCK-LOAD APPLICATIONS. THIS VALVE IS NOT RECOMMENDED FOR STEAM SERVICE OR FLOW MEDIA THAT CONTAINS SOLIDS. IT SHOULD BE INSTALLED AT LEAST FIVE PIPE DIAMETERS DOWNSTREAM FROM ANY TURBULENCE PRODUCING COMPONENTS. FLOW STRAIGHTENERS MAY BE REQUIRED IN CERTAIN APPLICATIONS.

The above data represents common market and service applications. No representation or guarantee, expressed or implied, is given due to the numerous variations of concentrations, temperatures and flow conditions that may occur during actual service.

TITAN FLOW CONTROL, INC.
YOUR PIPELINE TO THE FUTURE!

Tel: 910-735-0000 ♦ Fax: 910-738-3848 ♦ titan@titanfci.com ♦ www.titanfci.com
290 Corporate Drive ♦ PO Box 7408 ♦ Lumberton, NC 28358



TITAN FLOW CONTROL, Inc.
 290 Corporate Drive
 Lumberton, NC 28358
 Tel: 910.735.0000
 E-mail: titan@titanfci.com
 Web: www.titanfci.com
 Fax: 910.738.3848

SILENT CHECK VALVE • WAFER TYPE
CENTER GUIDED DESIGN • STAINLESS STEEL
MODEL: CV 91-SS - Stainless Steel Body

ANSI
Class
150/300

BILL OF MATERIALS (1)

No.	PART	CV 91-SS-S
1	Body (2)	A351 Gr. CF8M Type 316
2	Seat (3) (4)	A351 Gr. CF8M Type 316
3	Disc	A351 Gr. CF8M Type 316
4	Spring (4)	Series 300 Stainless Steel
5	Bushing (4)	A351 Gr. CF8M Type 316
6	Screws (4)	ASTM A276 Type 304 Stainless Steel

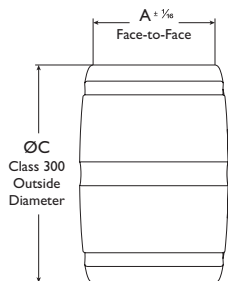

Side View

Illustration is representative of sizes 2" - 6".

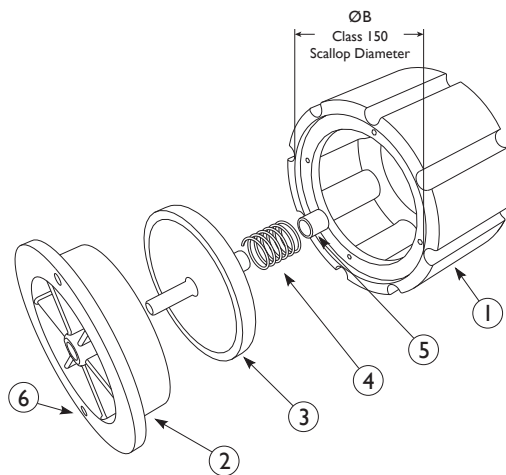

Exploded View

1. Bill of Materials represents standard materials. Equivalent or better materials may be substituted at the manufacturer's discretion.
2. Ductile Iron Bodies (CV90 Series) are also available.
3. Resilient, soft seats also available — Please consult factory.
4. Denotes recommended spare parts.

DIMENSIONS AND PERFORMANCE DATA (1)

SIZE	in	2	2 1/2	3	4	5	6	8 (2)	10 (2)	12 (2)
	mm	50	65	80	100	125	150	200	250	300
A DIMENSION FACE TO FACE	in	2.625	2.875	3.125	4.0	4.625	5.625	6.50	8.25	11.25
	mm	67	73	79	102	117	143	165	210	286
ØB DIMENSION SCALLOP DIAMETER 150 lb (2" THROUGH 12")	in	4.125	4.75	5.25	6.75	7.625	8.625	n/a	n/a	n/a
	mm	105	121	133	171	194	219	n/a	n/a	n/a
ØC DIMENSION OUTSIDE DIAMETER 300 lb (2" THROUGH 6")	in	4.25	5.0	5.75	7.0	8.375	9.75	n/a	n/a	n/a
	mm	108	127	146	178	213	248	n/a	n/a	n/a
ASSEMBLED WEIGHT	lb	4.5	6.5	8.5	18.0	25.0	54.0	70.0	140.0	324.0
	kg	2.0	2.9	3.9	8.2	11.3	24.5	31.8	63.5	146.8
Flow Coefficient	C _v	60	95	150	230	310	450	750	1250	1800
Cracking Pressure (3)	psi	≤ .5	≤ .5	≤ .5	≤ .5	≤ .5	≤ .5	≤ .5	≤ .5	≤ .5

Additional Design & Technical Notes:

Sizes 2" through 6" utilize a unique scallop design that permits dual pressure service (150/300). These sizes fit properly between any ANSI Class 125/250 or ANSI Class 150/300 flanges. Sizes 8" through 12" are only rated for ANSI Class 150 service. The bolting pattern for ANSI Class 125/250 and ANSI Class 150/300 are the same, respectively.

Valves are for liquid service only. They should be installed at least five pipe diameters downstream from any turbulence producing components.

Resilient soft seats are also available. Please contact factory for price and delivery.

1. Dimensions, weights, and flow coefficients are provided for reference only. When required, always request certified drawings.
2. Sizes 8", 10", and 12" are not scalloped, but tapping for cap screws is provided. Contact factory for diameter dimension if needed.
3. Cracking pressure is for horizontal installations only. For vertical installations, please consult factory.

PRESSURE-TEMPERATURE RATINGS (1)

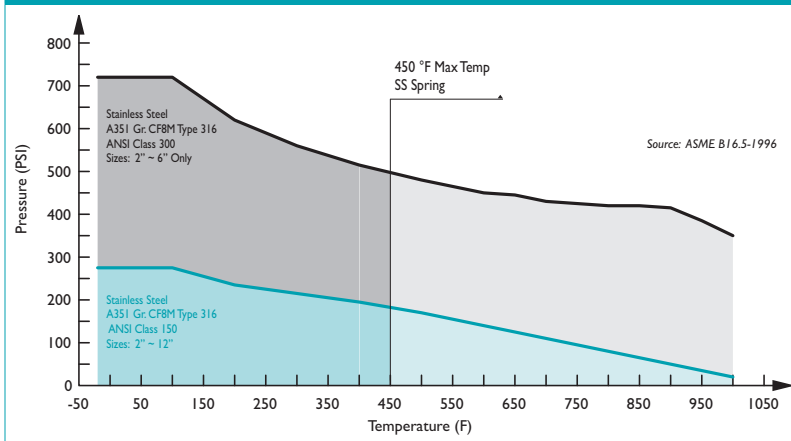

1. This chart displays the pressure-temperature ratings for the valve's body per ASME B16.5-1996. Maximum temperature limits have been added for seat and spring materials.

ORDERING CODE

Model Number	Description
CV91-SS-S	Stainless Steel Body, Stainless Steel Seat, Disc, and Seat

REFERENCED STANDARDS & CODES

CODE	DESCRIPTION
ANSI B16.5	Pipe Flanges and Flanged Fittings
MSS SP-6	Standards Finishes for Connecting-end Flanges
MSS SP-25	Standard Marking System for Valves
MSS SP-55	Quality Standard for Valve Castings
MSS SP-126	Steel, In-Line, Spring-Assisted, Center-Guided Valves

PRESSURE/TEMPERATURE RATING (1)

ANSI Class	150 lb Service 2" ~ 12"	300 lb Service 2" ~ 6" only
WOG (Non-shock)	275 PSI @ 100 °F	720 PSI @ 100 °F

SEAT AND SPRING TEMPERATURE RATINGS (1)

SEAT	Temperature Range
Metal	-325 °F @ 1500 °F
Buna-N	-20 °F @ 250 °F
SPRING	Maximum Temperature
Stainless Steel	450 °F

1. The listed pressure and temperature ratings for the valve's body, seat, and spring are theoretical and may vary during actual operating conditions.

Titan FCI makes every effort to ensure the information presented on our literature accurately reflects exact product specifications. However, as product changes occur, there may be short-term differences between actual product specifications and the information contained within our literature. Titan FCI reserves the right to make design and specification changes to improve our products without prior notification. When required, request certified drawings.



TITAN FLOW CONTROL, INC.

SILENT CHECK VALVE ♦ GLOBE TYPE ♦ CENTER GUIDED

ANSI CLASS 150 ♦ DUCTILE IRON ♦ FLANGED ENDS, FLAT FACE

MODEL: CV 50-DI

Body: Ductile Iron

Trim: Stainless Steel & Bronze

PATENT-PENDING
DESIGN WITH INTEGRAL
**STRAIGHTENING
VANES**



Sizes 2" ~ 12"

FEATURES

SIZE RANGE: 2" ~ 24"

LARGER SIZES AVAILABLE

♦ DESIGNED FOR LONG SERVICE LIFE

NEWLY DESIGNED CV50'S HAVE STRAIGHTENING VANES THAT REDUCE TURBULENCE IN INCOMING FLOW, THUS MINIMIZING NOISE, VIBRATIONS, EROSION, CAVITATIONS, AND OTHER FACTORS THAT COULD RESULT IN PREMATURE VALVE FAILURE.

♦ MINIMAL HEAD LOSS

HEAD LOSS IS MINIMIZED BY THE INTEGRAL STRAIGHTENING VANES THAT HELP CREATE LAMINAR FLOW. A LARGE CROSS-SECTIONAL AREA ALSO LESSENS PRESSURE DROP ACROSS THE CHECK VALVE. UNLIKE TYPICAL CONICAL SPRING CONSTRUCTIONS THAT RESTRICT FLOW, THE NEW CV 50 HAS A COMPRESSION SPRING COUPLED WITH A SMALL STEM GUIDE THAT ALLOWS FOR AN UNOBSTRUCTED FLOW PATH.

♦ QUICK CLOSURE TO REDUCE WATER HAMMER

SILENT SHUT-OFF IS ACHIEVED VIA THE FULLY AUTOMATIC, SPRING ASSISTED DISC THAT CLOSES NEAR ZERO FLOW VELOCITY. THE LIGHTWEIGHT, CENTER GUIDED DISC DESIGN CREATES A POSITIVE SHUTOFF PRIOR TO FLOW REVERSAL AND HELPS TO KEEP SLAMMING AND SURGES TO A MINIMUM. ADDITIONALLY, THE LOW CRACKING PRESSURE OF THE CV 50 REDUCES THE AMOUNT OF ENERGY REQUIRED TO OPEN THE VALVE.

♦ METAL-TO-METAL SEATS

PRECISION MACHINED SEALING SURFACES ALLOW THE CV 50-DI TO MAINTAIN A TIGHT SEAL THAT MEETS OR EXCEEDS API 598 LEAKAGE REQUIREMENTS. RESILIENT SEATS ARE ALSO AVAILABLE TO PROVIDE BUBBLE TIGHT SEALS. SEALING IS FURTHER IMPROVED BY AN ADDITIONAL GASKET ASSEMBLED WITH THE SEAT INDEPENDENT OF THE FLANGE GASKET.

♦ VERSATILE AND ECONOMIC DESIGN

CLEARANCE WITHIN THE CV 50'S BODY ALLOWS A BUTTERFLY VALVE TO BE INSTALLED DIRECTLY ON THE OUTLET SIDE OF THE VALVE WITHOUT EXTRA PIPING. BECAUSE THE VALVE'S TRIM IS INTERCHANGEABLE, VARIOUS SEATS, DISCS, AND SPRINGS ARE AVAILABLE AND EASY TO REPLACE. EXOTIC SPRING MATERIAL, SUCH AS MONEL OR INCONEL 750-X, CAN EASILY BE SUBSTITUTED FOR THE STANDARD STAINLESS STEEL

TECHNICAL

PRESSURE/TEMPERATURE RATING ⁽¹⁾
DUCTILE IRON - ASTM A536 - CLASS 150

WOG (Non-Shock): 250 PSI @ 100 °F

SEAT MATERIAL
TEMPERATURE RANGE

ALUMINUM BRONZE: -460 ~ 600 °F
STAINLESS STEEL: -325 ~ 1500 °F

SPRING MATERIAL
MAXIMUM TEMPERATURE

STAINLESS STEEL: 450 °F

1. The above listed temperatures are theoretical and may vary during actual operating conditions.

APPLICATIONS

MARKETS: OIL AND GAS PRODUCTION, GENERAL INDUSTRY, CHEMICAL, PETROCHEMICAL, POWER, FOOD AND BEVERAGE

SERVICE: PUMP DISCHARGE SERVICE IN MUNICIPAL WATER, IRRIGATION, AND INDUSTRIAL CLASS HVAC SYSTEMS. IT IS RECOMMENDED THAT A TITAN FCI STRAINER BE INSTALLED AHEAD OF THE PUMP TO ENSURE PROTECTION OF THE CHECK VALVE AND THE PUMP.

PRECAUTIONS: THIS VALVE IS INTENDED FOR LIQUID SERVICE THAT DOES NOT EXCEED 10 FT/SEC. IT IS DESIGNED FOR STEADY FLOW CONDITIONS AND IS NOT RECOMMENDED FOR USE IN RECIPROCATING PUMP, COMPRESSOR OR OTHER TYPE OF PHYSICAL/THERMAL SHOCK-LOAD APPLICATIONS. THIS VALVE IS NOT RECOMMENDED FOR STEAM SERVICE OR FLOW MEDIA THAT CONTAINS SOLIDS. IT SHOULD BE INSTALLED AT LEAST FIVE PIPE DIAMETERS DOWNSTREAM FROM ANY TURBULENCE PRODUCING COMPONENTS. FLOW STRAIGHTENERS MAY BE REQUIRED IN CERTAIN APPLICATIONS.

The above data represents common market and service applications. No representation or guarantee, expressed or implied, is given due to the numerous variations of concentrations, temperatures and flow conditions that may occur during actual service.

TITAN FLOW CONTROL, INC.

YOUR PIPELINE TO THE FUTURE!

Tel: 910-735-0000 ♦ Fax: 910-738-3848 ♦ titan@titanfci.com ♦ www.titanfci.com
290 Corporate Drive ♦ PO Box 7408 ♦ Lumberton, NC 28358



TITAN FLOW CONTROL, Inc.

290 Corporate Drive
Lumberton, NC 28358
Tel: 910.735.0000

E-mail: titan@titanfci.com
Web: www.titanfci.com
Fax: 910.738.3848

SILENT CHECK VALVE • GLOBE TYPE

CV 50-DI (Ductile Iron)

ANSI Class
150

Flanged Ends, Flat Faced • Globe Style • Center Guided Disc

BILL OF MATERIALS (1)

No.	PART	CV 50-DI-B	CV 50-DI-S
1	Body	Ductile Iron ASTM A536	Ductile Iron ASTM A536
2	Disc (2)	Aluminum Bronze ASTM B148	Stainless Steel Gr. CF8M Type 316 SS
3	Spring (2)	Series 300 Stainless Steel	Series 300 Stainless Steel
4	Bushing (2)	Aluminum Bronze	Stainless Steel
5	Seat (2) (3)	Aluminum Bronze ASTM B148	Stainless Steel Gr. CF8M Type 316 SS
6	Cap Screw	Stainless Steel	Stainless Steel
7	Gasket	Non-asbestos Gasket	Non-asbestos Gasket

Illustrations are for representational purposes only. Please ask for certified drawings when necessary.

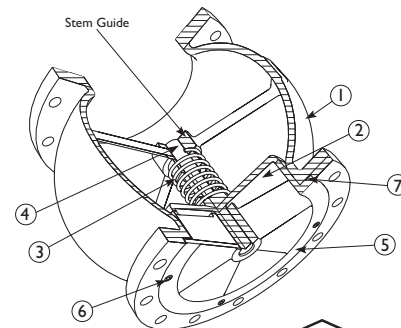
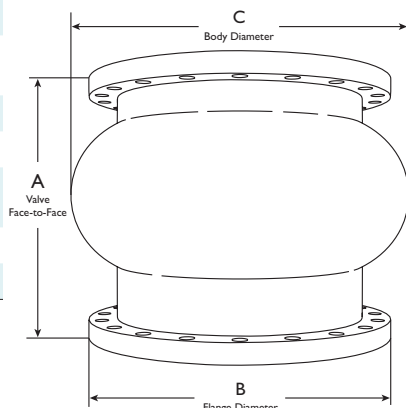

1. Bill of Materials represents standard materials. Equivalent or better materials may be substituted at the manufacturer's discretion.
2. Denotes recommended spare parts.
3. Resilient Seats are available upon request. Please call for details.

Additional Design & Technical Notes:

- The CV 50-DI is designed to fit Cast Iron Class 125 and Ductile Iron Class 150 Flanges. The bolting pattern for Cast Iron Class 125 and Ductile Iron Class 150 are identical.
- Ductile Iron maintains the anti-corrosive properties of Cast Iron while achieving a yield strength comparable to Carbon Steel. It also offers higher pressure/temp ratings than Cast Iron.
- All CV 50-DI valve bodies are epoxy painted.

DIMENSIONS AND PERFORMANCE DATA (1)

SIZE	in	2	2 1/2	3	4	5	6	8	10	12	14	16	18	20	24
	mm	50	65	80	100	125	150	200	250	300	350	400	450	500	600
A DIMENSION FACE TO FACE (2)	in	6.25	7.00	7.50	8.50	9.50	10.50	13.50	16.25	20.25	22.75	24.75	22.50	24.00	24.00
	mm	159	178	191	216	241	267	343	413	514	578	629	572	610	610
ØB DIMENSION FLANGE DIAMETER	in	6.00	7.00	7.50	9.00	10.00	11.00	13.50	16.00	19.00	21.00	23.50	25.00	27.50	32.00
	mm	153	178	191	229	254	280	343	406	483	533	597	635	699	813
ØC DIMENSION BODY DIAMETER	in	4.625	5.75	6.625	8.625	10.00	11.125	15.84	17.687	21.25	23.95	25.875	29.0	32.75	36.96
	mm	117	146	168	219	254	283	402	449	540	608	657	737	832	939
WEIGHT (APPROXIMATE)	lb	14.0	24.0	27.5	44.0	C/F	83.0	145.0	220.0	344.0	453.5	593.0	695.5	963.0	C/F
	kg	6.4	10.9	12.5	20.0	C/F	37.6	65.8	99.8	156.0	205.7	269.0	315.5	436.8	C/F
Flow Coefficient	C _v	65	105	150	265	410	600	1100	1800	2500	3100	4300	5000	6300	9800
Cracking Pressure (3)	psi	≤ .5	≤ .5	≤ .5	≤ .5	≤ .5	≤ .5	≤ .5	≤ .5	≤ .5	≤ .5	≤ .5	≤ .5	≤ .5	≤ .5

1. Dimensions, weights, and flow coefficients are provided for reference only. When required, always request certified drawings.
2. Face to face values have a tolerance of ±0.06 in (±2.0 mm) for sizes 10" and lower and a tolerance of ±0.12 in (±3.0 mm) for sizes 12" and larger.
3. Cracking pressure is for horizontal installations only. For vertical installations, please consult factory.

PRESSURE - TEMPERATURE RATINGS (1)

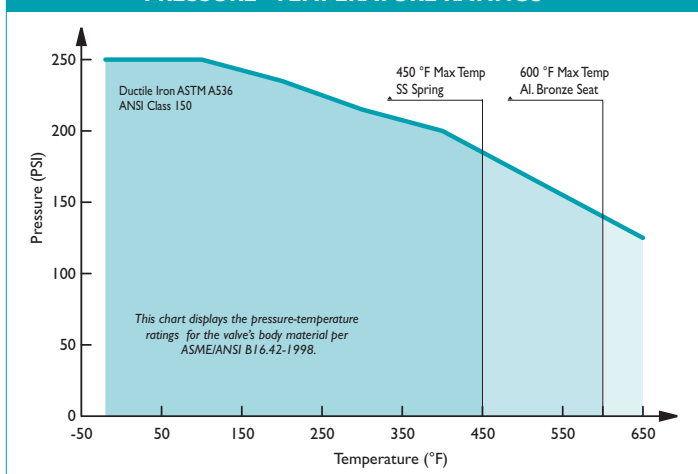

1. This chart displays the pressure-temperature ratings for the valve's body. Max temperature limits have been added for seat and spring materials.

REFERENCED STANDARDS & CODES

CODE	DESCRIPTION
ANSI B16.42	Ductile Iron Pipe Flanges and Flanged Fittings
ANSI B16.5	Pipe Flanges & Flanged Fittings
MSS SP-6	Standard Finishes for Connecting-end Flanges
MSS SP-25	Standard Marking System for Valves
MSS SP-55	Quality Standard for Valve Castings
FM APPROVALS 1230	Anti-Water Hammer Check Valves (2" ~12")

PRESSURE - TEMPERATURE RATING

ANSI CLASS 150	ASTM A536
WOG (Non-Shock)	250 PSI @ 100 °F

TEMPERATURE RANGE SEAT

SEAT	Temperature
Aluminum Bronze	-460 °F @ 600 °F
Stainless Steel	-325 ~ 1500 °F

MAX TEMPERATURE SPRING

SPRING	Max Temperature
Stainless Steel	450 °F

The listed pressure and temperature ratings for the valve's body, seat, and spring are theoretical and may vary during actual operating conditions.

ORDERING CODE

Model Number	Description
CV50-DI-B	Ductile Iron Body, Bronze Seat and Disc
CV50-DI-S	Ductile Iron Body, Stainless Steel Seat and Disc

Titan FCI makes every effort to ensure the information presented on our literature accurately reflects exact product specifications. However, as product changes occur, there may be short-term differences between actual product specifications and the information contained within our literature. Titan FCI reserves the right to make design and specification changes to improve our products without prior notification. When required, request certified drawings.



TITAN FLOW CONTROL, INC.

SILENT CHECK VALVE ♦ GLOBE TYPE ♦ CENTER GUIDED

ANSI CLASS 150 ♦ CARBON & STAINLESS STEEL ♦ FLANGED ENDS (RF)

MODELS: CV 51-CS CV 51-SS

Body: Carbon & Stainless Steel
Trim: Stainless Steel

PATENT-PENDING
DESIGN WITH INTEGRAL
STRAIGHTENING
VANES



FEATURES

SIZE RANGE: 2" ~ 24"

LARGER SIZES AVAILABLE

DESIGNED FOR LONG SERVICE LIFE

NEWLY DESIGNED CV51'S HAVE STRAIGHTENING VANES THAT REDUCE TURBULENCE IN INCOMING FLOW, THUS MINIMIZING NOISE, VIBRATIONS, EROSION, CAVITATIONS, AND OTHER FACTORS THAT COULD RESULT IN PREMATURE VALVE FAILURE.

MINIMAL HEAD LOSS

HEAD LOSS IS MINIMIZED BY THE INTEGRAL STRAIGHTENING VANES THAT HELP CREATE LAMINAR FLOW. A LARGE CROSS-SECTIONAL AREA ALSO LESSENS PRESSURE DROP ACROSS THE CHECK VALVE. UNLIKE TYPICAL CONICAL SPRING CONSTRUCTIONS THAT RESTRICT FLOW, THE NEW CV 51 HAS A COMPRESSION SPRING COUPLED WITH A SMALL STEM GUIDE THAT ALLOWS FOR AN UNOBSTRUCTED FLOW PATH.

QUICK CLOSURE TO REDUCE WATER HAMMER

SILENT SHUT-OFF IS ACHIEVED VIA THE FULLY AUTOMATIC, SPRING ASSISTED DISC THAT CLOSES NEAR ZERO FLOW VELOCITY. THE LIGHTWEIGHT, CENTER GUIDED DISC DESIGN CREATES A POSITIVE SHUTOFF PRIOR TO FLOW REVERSAL AND HELPS TO KEEP SLAMMING AND SURGES TO A MINIMUM. ADDITIONALLY, THE LOW CRACKING PRESSURE OF THE CV 51 REDUCES THE AMOUNT OF ENERGY REQUIRED TO OPEN THE VALVE.

METAL-TO-METAL SEATS

PRECISION MACHINED SEALING SURFACES ALLOW THE CV 51-CS/SS TO MAINTAIN A TIGHT SEAL THAT MEETS OR EXCEEDS API 598 LEAKAGE REQUIREMENTS. RESILIENT SEATS ARE ALSO AVAILABLE TO PROVIDE BUBBLE TIGHT SEALS. SEALING IS FURTHER IMPROVED BY AN ADDITIONAL GASKET ASSEMBLED WITH THE SEAT INDEPENDENT OF THE FLANGE GASKET.

VERSATILE AND ECONOMIC DESIGN

CLEARANCE WITHIN THE CV 51'S BODY ALLOWS A BUTTERFLY VALVE TO BE INSTALLED DIRECTLY ON THE OUTLET SIDE OF THE VALVE WITHOUT EXTRA PIPING. BECAUSE THE VALVE'S TRIM IS INTERCHANGEABLE, VARIOUS SEATS, DISCS, AND SPRINGS ARE AVAILABLE AND EASY TO REPLACE. EXOTIC SPRING MATERIAL, SUCH AS MONEL OR INCONEL 750-X, CAN EASILY BE SUBSTITUTED FOR THE STANDARD STAINLESS STEEL.

TECHNICAL

PRESSURE/TEMPERATURE RATING ⁽¹⁾
CS - ASTM A216 Gr. WCB - CLASS 150

WOG (Non-shock): 285 PSI @ 100 °F

PRESSURE/TEMPERATURE RATING ⁽¹⁾
SS - ASTM A351 Gr. CF8M - CLASS 150

WOG (Non-shock): 275 PSI @ 100 °F

SEAT MATERIAL ⁽¹⁾
TEMPERATURE RANGE

STAINLESS STEEL: -325 ~ 1500 °F

SPRING MATERIAL ⁽¹⁾
MAXIMUM TEMPERATURE

STAINLESS STEEL: 450 °F

1. The above listed temperatures are theoretical and may vary during actual operating conditions.

APPLICATIONS

MARKETS: OIL AND GAS PRODUCTION, GENERAL INDUSTRY, CHEMICAL, PETROCHEMICAL, POWER, FOOD AND BEVERAGE

SERVICE: PUMP DISCHARGE SERVICE IN MUNICIPAL WATER, IRRIGATION, AND INDUSTRIAL CLASS HVAC SYSTEMS. IT IS RECOMMENDED THAT A TITAN FCI STRAINER BE INSTALLED AHEAD OF THE PUMP TO ENSURE PROTECTION OF THE CHECK VALVE AND THE PUMP.

PRECAUTIONS: THIS VALVE IS INTENDED FOR LIQUID SERVICE THAT DOES NOT EXCEED 10 FT/SEC. IT IS DESIGNED FOR STEADY FLOW CONDITIONS AND IS NOT RECOMMENDED FOR USE IN RECIPROCATING PUMP, COMPRESSOR OR OTHER TYPE OF PHYSICAL/THERMAL SHOCK-LOAD APPLICATIONS. THIS VALVE IS NOT RECOMMENDED FOR STEAM SERVICE OR FLOW MEDIA THAT CONTAINS SOLIDS. IT SHOULD BE INSTALLED AT LEAST FIVE PIPE DIAMETERS DOWNSTREAM FROM ANY TURBULENCE PRODUCING COMPONENTS. ADDITIONAL FLOW STRAIGHTENERS MAY BE REQUIRED IN CERTAIN APPLICATIONS.

The above data represents common market and service applications. No representation or guarantee, expressed or implied, is given due to the numerous variations of concentrations, temperatures and flow conditions that may occur during actual service.

TITAN FLOW CONTROL, INC.

YOUR PIPELINE TO THE FUTURE!

Tel: 910-735-0000 ♦ Fax: 910-738-3848 ♦ titan@titanfci.com ♦ www.titanfci.com
290 Corporate Drive ♦ PO Box 7408 ♦ Lumberton, NC 28358



TITAN FLOW CONTROL, Inc.

290 Corporate Drive
Lumberton, NC 28358
Tel: 910.735.0000

E-mail: titan@titanfci.com
Web: www.titanfci.com
Fax: 910.738.3848

SILENT CHECK VALVE • GLOBE TYPE
CV 51-CS (Carbon) CV 51-SS (Stainless Steel)

ANSI Class
150

Flanged Ends (RF) • Globe Style • Center Guided Disc

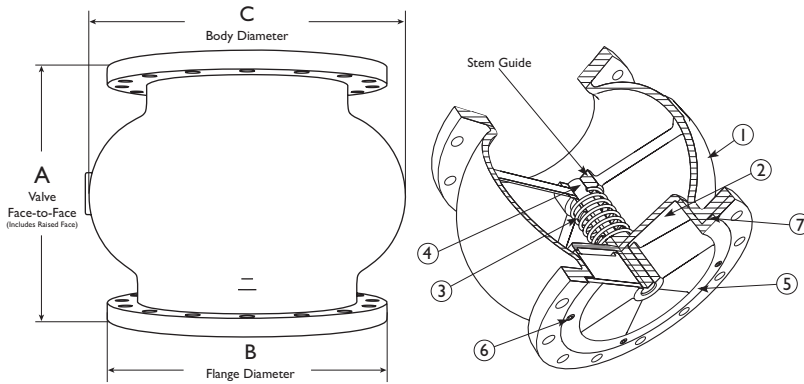

Application/Additional Notes:

- Face-to-Face Dimension 'A' includes raised face. Class 150 flanges are regularly furnished with 1/16 inch high raised face.
- Carbon Steel bodies are epoxy painted. Other coatings are available; please contact factory for details.
- Contact Titan FCI Engineering for flexible expansion joint applications.

BILL OF MATERIALS (1)

No.	PART	CV 51-CS	CV 51-SS
1	Body	Carbon Steel A216 Gr. WCB	Stainless Steel A351 Gr. CF8M Type 316
2	Disc (2)	Stainless Steel Gr. CF8M Type 316	Stainless Steel Gr. CF8M Type 316
3	Spring (2)	Series 300 Stainless Steel	Series 300 Stainless Steel
4	Bushing (2)	Stainless Steel	Stainless Steel
5	Seat (2) (3)	Stainless Steel Gr. CF8M Type 316	Stainless Steel Gr. CF8M Type 316
6	Cap Screw	Stainless Steel	Stainless Steel
7	Gasket (2)	Non-asbestos Gasket	Non-asbestos Gasket

1. Bill of Materials represents standard materials. Equivalent or better materials may be substituted at the manufacturer's discretion.
2. Denotes recommended spare parts.
3. Resilient Seats are available upon request. Please call for details.

DIMENSIONS AND PERFORMANCE DATA (1)

SIZE (2)	in	2	2 1/2	3	4	5	6	8	10	12	14	16	18	20	24
	mm	50	65	80	100	125	150	200	250	300	350	400	450	500	600
A DIMENSION FACE TO FACE (3)	in	6.25	C/F	7.55	8.50	C/F	10.50	12.0	14.0	18.0	19.50	21.0	22.5	24.0	24.0
	mm	159	C/F	192	216	C/F	267	305	356	457	495	533	572	610	661
ØB DIMENSION FLANGE DIAMETER	in	6.00	C/F	7.50	9.00	C/F	11.00	13.50	16.00	19.00	21.00	23.5	25.0	27.5	32.0
	mm	152	C/F	191	229	C/F	279	343	406	483	533	597	572	699	813
ØC DIMENSION BODY DIAMETER	in	4.63	C/F	6.63	8.62	C/F	11.13	15.84	17.69	21.25	24.0	26.5	29.0	32.75	37.0
	mm	118	C/F	168	219	C/F	283	402	449	540	610	673	737	832	940
WEIGHT (APPROXIMATE)	lb	15.2	C/F	30.0	49.0	C/F	80.0	138.0	165.0	310.0	420.0	593.0	690.0	970.0	1500
	kg	6.3	C/F	13.6	22.2	C/F	36.3	62.4	74.8	140.6	190.5	268.2	312.1	438.8	681
Flow Coefficient	C _v	65	C/F	150	265	C/F	600	1100	1800	2500	3100	4800	6100	7800	9800
Cracking Pressure (4)	psi	≤ .5	C/F	≤ .5	≤ .5	C/F	≤ .5	≤ .5	≤ .5	≤ .5	≤ .5	≤ .5	≤ .5	≤ .5	≤ .5

1. Dimensions, weights, and flow coefficients are provided for reference only. When required, always request certified drawings.
2. Larger sizes are available. Please consult factory for these sizes and dimensions.
3. Face to face values have a tolerance of ±0.06 in (±2.0 mm) for sizes 10" and lower and a tolerance of ±0.12 in (±3.0 mm) for sizes 12" and larger.
4. Cracking pressure is for horizontal installations only. For vertical installations, please consult factory.

PRESSURE - TEMPERATURE RATINGS (1)

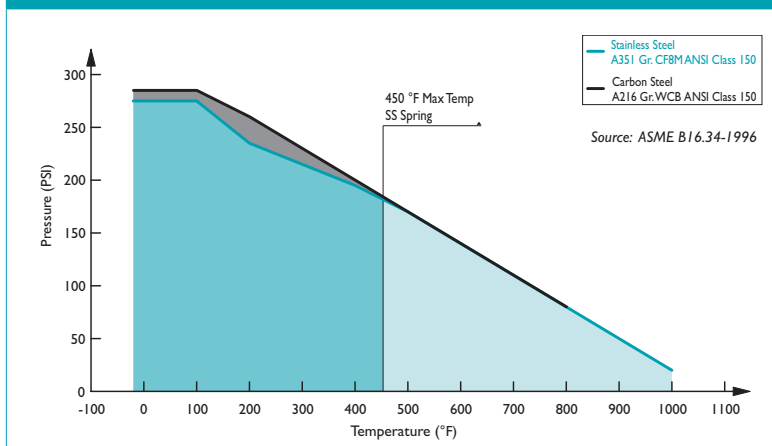

1. This chart displays the pressure-temperature ratings for the valve's body. Max temperature limits have been added for the spring material.

ORDERING CODE

Model Number	Description
CV51-CS	Carbon Steel Body, Stainless Steel Seat and Disc
CV51-SS	Stainless Steel Body, Stainless Steel Seat and Disc

REFERENCED STANDARDS & CODES

CODE	DESCRIPTION
ANSI B16.5	Pipe Flanges & Flanged Fittings
ANSI/API 594	Valve Design and Manufacture
API 598	Valve Inspection and Pressure Test
MSS SP-6	Standard Finishes for Connecting-end Flanges
MSS SP-25	Standard Marking System for Valves
MSS SP-55	Quality Standard for Valve Castings

PRESSURE - TEMPERATURE RATING

ANSI CLASS 150	Carbon Steel	Stainless Steel
WOG (Non-shock)	285 PSI @ 100 °F	275 PSI @ 100 °F

TEMPERATURE RANGE SEAT

SEAT	Temperature
Stainless Steel	-325 ~ 1500 °F

MAX TEMPERATURE SPRING

SPRING	Max Temperature
Stainless Steel	450 °F

The listed pressure and temperature ratings for the valve's body, seat, and spring are theoretical and may vary during actual operating conditions.

Titan FCI makes every effort to ensure the information presented on our literature accurately reflects exact product specifications. However, as product changes occur, there may be short-term differences between actual product specifications and the information contained within our literature. Titan FCI reserves the right to make design and specification changes to improve our products without prior notification. When required, request certified drawings.



TITAN FLOW CONTROL, INC.

SILENT CHECK VALVE ♦ GLOBE TYPE ♦ CENTER GUIDED

ANSI CLASS 300 ♦ DUCTILE IRON ♦ FLANGED ENDS RAISED FACE

MODEL: CV 52-DI

Body: Ductile Iron

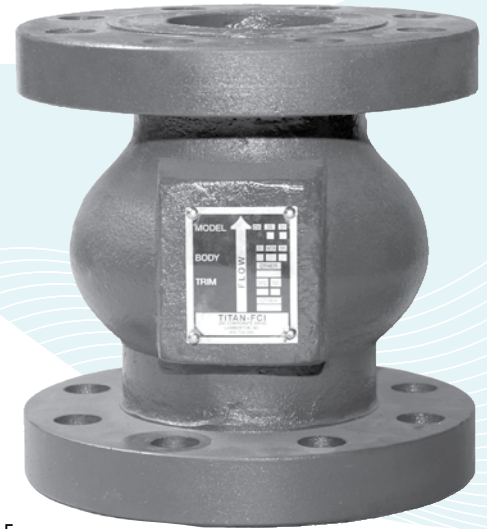
Trim: Stainless Steel &
Aluminum Bronze

FEATURES

SIZE RANGE: 2" ~ 24"

LARGER SIZES AVAILABLE

- ♦ **DESIGNED FOR LONG SERVICE LIFE**
DUCTILE IRON BODY MAINTAINS THE ANTI-CORROSIVE PROPERTIES OF CAST IRON WHILE ACHIEVING A YIELD STRENGTH COMPARABLE TO CARBON STEEL. DUCTILE IRON CHECK VALVES ALSO OFFER HIGHER PRESSURE AND TEMPERATURE RATINGS WHEN COMPARED TO CAST IRON CHECK VALVES OF THE SAME CLASS.
- ♦ **MINIMAL HEAD LOSS**
HEAD LOSS IS MINIMIZED BY PROVIDING A LARGE CROSS-SECTIONAL AREA WHICH EXCEEDS THAT OF THE ADJACENT PIPELINE. ADDITIONALLY, THE SPRING-LOADED, CENTER GUIDED DISC IS DESIGNED WITH VERY LOW CRACKING PRESSURE WHICH REDUCES THE AMOUNT OF ENERGY REQUIRED TO OPEN THE VALVE.
- ♦ **QUICK CLOSURE TO REDUCE WATER HAMMER**
SILENT SHUT-OFF IS ACHIEVED VIA THE FULLY AUTOMATIC, SPRING ASSISTED DISC THAT CLOSURES NEAR ZERO FLOW VELOCITY. THE LIGHTWEIGHT, CENTER GUIDED DISC DESIGN CREATES A POSITIVE SHUTOFF PRIOR TO FLOW REVERSAL AND HELPS TO KEEP SLAMMING AND SURGES TO A MINIMUM.
- ♦ **METAL-TO-METAL SEATS**
PRECISION MACHINED SEALING SURFACES ALLOW THE CV 52-DI TO MAINTAIN A TIGHT SEAL THAT MEETS OR EXCEEDS API 598 LEAKAGE REQUIREMENTS. RESILIENT SEATS ARE ALSO AVAILABLE TO PROVIDE BUBBLE TIGHT SEALS*.
* AVAILABLE BY SPECIAL ORDER
- ♦ **VERSATILE DESIGN**
THIS VALVE CAN BE INSTALLED IN ANY POSITION (HORIZONTAL OR VERTICAL WITH UPWARD FLOW)*. CERTAIN SIZES ALLOW DIRECT MOUNTING OF A WAFER TYPE BUTTERFLY VALVE TO THE OUTLET END WITHOUT REQUIRING A SPACE FLANGE OR SPOOL PIECE.
* VERTICAL FLOW - CONSULT FACTORY

TECHNICAL

PRESSURE/TEMPERATURE RATING ⁽¹⁾
DUCTILE IRON - ASTM A536 - CLASS 300

WOG (Non-Shock): 640 PSI @ 100 °F

SEAT MATERIAL
TEMPERATURE RANGE

ALUMINUM BRONZE: -460 ~ 600 °F
STAINLESS STEEL: -325 ~ 1500 °F

SPRING MATERIAL
MAXIMUM TEMPERATURE

STAINLESS STEEL: 450 °F

1. The above listed temperatures are theoretical and may vary during actual operating conditions.

APPLICATIONS

MARKETS: OIL AND GAS PRODUCTION, GENERAL INDUSTRY, CHEMICAL, PETROCHEMICAL, POWER, FOOD AND BEVERAGE

SERVICE: PUMP DISCHARGE SERVICE IN MUNICIPAL WATER, IRRIGATION, AND INDUSTRIAL CLASS HVAC SYSTEMS. IT IS RECOMMENDED THAT A TITAN FCI STRAINER BE INSTALLED AHEAD OF THE PUMP TO ENSURE PROTECTION OF THE CHECK VALVE AND THE PUMP.

PRECAUTIONS: THIS VALVE IS INTENDED FOR LIQUID SERVICE THAT DOES NOT EXCEED 10 FT/SEC. IT IS DESIGNED FOR STEADY FLOW CONDITIONS AND IS NOT RECOMMENDED FOR USE IN RECIPROCATING PUMP, COMPRESSOR OR OTHER TYPE OF PHYSICAL/THERMAL SHOCK-LOAD APPLICATIONS. THIS VALVE IS NOT RECOMMENDED FOR STEAM SERVICE OR FLOW MEDIA THAT CONTAINS SOLIDS. IT SHOULD BE INSTALLED AT LEAST FIVE PIPE DIAMETERS DOWNSTREAM FROM ANY TURBULENCE PRODUCING COMPONENTS. FLOW STRAIGHTENERS MAY BE REQUIRED IN CERTAIN APPLICATIONS.

The above data represents common market and service applications. No representation or guarantee, expressed or implied, is given due to the numerous variations of concentrations, temperatures and flow conditions that may occur during actual service.

TITAN FLOW CONTROL, INC.

YOUR PIPELINE TO THE FUTURE!

Tel: 910-735-0000 ♦ Fax: 910-738-3848 ♦ titan@titanfci.com ♦ www.titanfci.com
290 Corporate Drive ♦ PO Box 7408 ♦ Lumberton, NC 28358



TITAN FLOW CONTROL, Inc.

290 Corporate Drive
Lumberton, NC 28358
Tel: 910.735.0000

E-mail: titan@titanfci.com
Web: www.titanfci.com
Fax: 910.738.3848

SILENT CHECK VALVE • GLOBE TYPE

CV 52-DI (Ductile Iron)

Flanged Ends Raised Face • Globe Style • Center Guided Disc

**ANSI
Class
250/300**

BILL OF MATERIALS ⁽¹⁾

No.	PART	CV 52-DI-B	CV 52-DI-S
1	Body	Ductile Iron ASTM A536	Ductile Iron ASTM A536
2	Disc ⁽²⁾	Aluminum Bronze ASTM B148	Stainless Steel Gr. CF8M Type 316 SS
3	Spring ⁽²⁾	Series 300 Stainless Steel	Series 300 Stainless Steel
4	Bushing ⁽²⁾	Bronze	Stainless Steel
5	Seat ^{(2) (3)}	Aluminum Bronze ASTM B148	Stainless Steel Gr. CF8M Type 316 SS
6	Cap Screw	Stainless Steel	Stainless Steel

1. Bill of Materials represents standard materials. Equivalent or better materials may be substituted at the manufacturer's discretion.
2. Denotes recommended spare parts.
3. Resilient Seats are available upon request. Please call for details.

Additional Design & Technical Notes:

- The CV 52-DI is designed to fit Cast Iron Class 250 and Ductile Iron Class 300 Flanges. The bolting pattern for Cast Iron Class 250 and Ductile Iron Class 300 are identical.
- All valve bodies are epoxy painted.

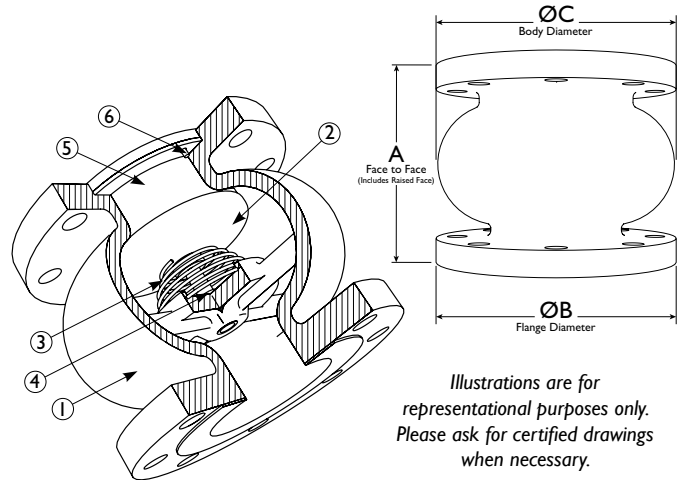

DIMENSIONS AND PERFORMANCE DATA ⁽¹⁾

SIZE	in	2	2 1/2	3	4	5	6	8	10	12	14	16	18	20	24
	mm	50	65	80	100	125	150	200	250	300	350	400	450	500	600
A DIMENSION FACE TO FACE	in	6.75	7.625	8.25	9.125	10.0	11.375	14.0	17.0	20.875	23.375	25.625	24.125	25.625	26.0
	mm	172	194	210	232	254	289	356	432	531	594	651	613	651	661
ØB DIMENSION FLANGE DIAMETER	in	6.5	7.5	8.25	10.0	11.0	12.5	15.0	17.5	20.5	23.0	25.5	28.0	30.5	36.0
	mm	166	191	210	254	280	318	381	445	521	585	648	712	775	915
ØC DIMENSION BELLY DIAMETER	in	4.875	5.75	6.625	8.875	10.375	11.5	15.0	17.875	22.125	24.25	26.875	30.0	33.25	37.0
	mm	124	147	169	226	264	293	381	455	562	616	683	762	845	940
ASSEMBLED WEIGHT	lb	21	30	39	64	93	125	198	303	432	612	1000	1238	1775	2500
	kg	9.5	13.6	17.7	29.0	42.2	56.7	89.8	137.4	196.0	277.6	453.1	560.9	804.3	1132.8
Flow Coefficient	C _v	65	105	150	265	410	600	1100	1800	2500	3100	4300	5000	6300	9800
Cracking Pressure ⁽²⁾	psi	≤ .5	≤ .5	≤ .5	≤ .5	≤ .5	≤ .5	≤ .5	≤ .5	≤ .5	≤ .5	≤ .5	≤ .5	≤ .5	≤ .5

1. Dimensions, weights, and flow coefficients are provided for reference only. When required, always request certified drawings.
2. Cracking pressure is for horizontal installations only. For vertical installations, please consult factory.

PRESSURE-TEMPERATURE RATINGS ⁽¹⁾

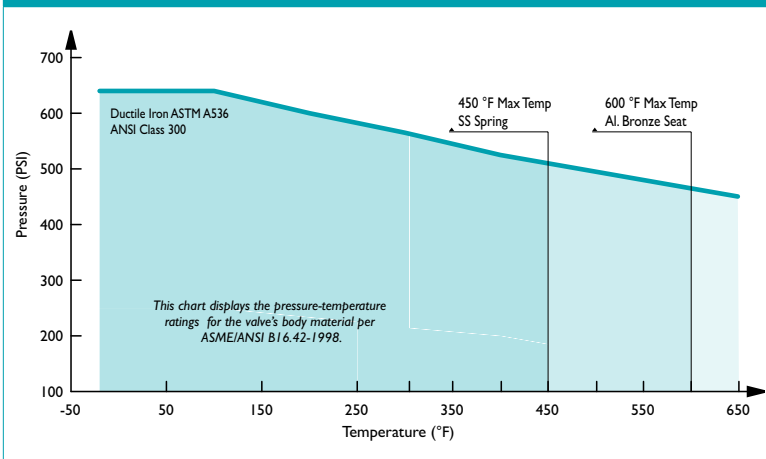

1. This chart displays the pressure-temperature ratings for the valve's body per ASME B16.42-1998. Max temperature limits have been added for seat and spring materials.

ORDERING CODE

Model Number	Description
CV52-DI-B	Ductile Iron Body, Aluminum Bronze Seat and Disc
CV52-DI-S	Ductile Iron Body, Stainless Steel Seat and Disc

REFERENCED STANDARDS & CODES

CODE	DESCRIPTION
ANSI B16.42	Ductile Iron Pipe Flanges and Flanged Fittings
ANSI B16.5	Pipe Flanges & Flanged Fittings
MSS SP-6	Standard Finishes for Connecting-end Flanges
MSS SP-25	Standard Marking System for Valves
MSS SP-55	Quality Standard for Valve Castings

PRESSURE/TEMPERATURE RATING

Pressure Class	D.I. A536 CLASS 300
WOG (Non-Shock)	640 PSI @ 100 °F ⁽¹⁾

1. Ductile Iron check valves offer higher pressure ratings than Cast Iron check valves. For example, Ductile Iron check valves (2" ~ 24") are rated at 640 PSI WOG. By comparison, Cast Iron check valves (2" ~ 12") are rated at 500 PSI WOG and (14" ~ 24") are only rated at 300 PSI WOG.

TEMPERATURE RANGE SEAT

SEAT	Temperature
Aluminum Bronze	-460 ~ 600 °F
Stainless Steel	-325 ~ 1500 °F

MAX TEMPERATURE SPRING

SPRING	Max Temperature
Stainless Steel	450 °F

The listed pressure and temperature ratings for the valve's body, seat, and spring are theoretical and may vary during actual operating conditions.

Titan FCI makes every effort to ensure the information presented on our literature accurately reflects exact product specifications. However, as product changes occur, there may be short-term differences between actual product specifications and the information contained within our literature. Titan FCI reserves the right to make design and specification changes to improve our products without prior notification. When required, request certified drawings.



TITAN FLOW CONTROL, INC.

SILENT CHECK VALVE ♦ GLOBE TYPE ♦ CENTER GUIDED

ANSI CLASS 300 ♦ CARBON & STAINLESS STEEL ♦ FLANGED ENDS (RF)

MODELS: CV 52-CS CV 52-SS

Body: Carbon & Stainless Steel
Trim: Stainless Steel

PATENT-PENDING
DESIGN WITH INTEGRAL
STRAIGHTENING
VANES



FEATURES

SIZE RANGE: 2" ~ 14"

LARGER SIZES AVAILABLE

◇ DESIGNED FOR LONG SERVICE LIFE

NEWLY DESIGNED CV52'S HAVE STRAIGHTENING VANES THAT REDUCE TURBULENCE IN INCOMING FLOW, THUS MINIMIZING NOISE, VIBRATIONS, EROSION, CAVITATIONS, AND OTHER FACTORS THAT COULD RESULT IN PREMATURE VALVE FAILURE.

◇ MINIMAL HEAD LOSS

HEAD LOSS IS MINIMIZED BY THE INTEGRAL STRAIGHTENING VANES THAT HELP CREATE LAMINAR FLOW. A LARGE CROSS-SECTIONAL AREA ALSO LESSENS PRESSURE DROP ACROSS THE CHECK VALVE. UNLIKE TYPICAL CONICAL SPRING CONSTRUCTIONS THAT RESTRICT FLOW, THE NEW CV 52 HAS A COMPRESSION SPRING COUPLED WITH A SMALL STEM GUIDE THAT ALLOWS FOR AN UNOBSTRUCTED FLOW PATH.

◇ QUICK CLOSURE TO REDUCE WATER HAMMER

SILENT SHUTOFF IS ACHIEVED VIA THE FULLY AUTOMATIC, SPRING ASSISTED DISC THAT CLOSURES NEAR ZERO FLOW VELOCITY. THE LIGHTWEIGHT, CENTER GUIDED DISC DESIGN CREATES A POSITIVE SHUTOFF PRIOR TO FLOW REVERSAL AND HELPS TO KEEP SLAMMING AND SURGES TO A MINIMUM. ADDITIONALLY, THE LOW CRACKING PRESSURE OF THE CV 52 REDUCES THE AMOUNT OF ENERGY REQUIRED TO OPEN THE VALVE.

◇ METAL-TO-METAL SEATS

PRECISION MACHINED SEALING SURFACES ALLOW THE CV 52-CS/SS TO MAINTAIN A TIGHT SEAL THAT MEETS OR EXCEEDS API 598 LEAKAGE REQUIREMENTS. RESILIENT SEATS ARE ALSO AVAILABLE TO PROVIDE BUBBLE TIGHT SEALS. SEALING IS FURTHER IMPROVED BY AN ADDITIONAL GASKET ASSEMBLED WITH THE SEAT INDEPENDENT OF THE FLANGE GASKET.

◇ VERSATILE AND ECONOMIC DESIGN

CLEARANCE WITHIN THE CV 52'S BODY ALLOWS A BUTTERFLY VALVE TO BE INSTALLED DIRECTLY ON THE OUTLET SIDE OF THE VALVE WITHOUT EXTRA PIPING. BECAUSE THE VALVE'S TRIM IS INTERCHANGEABLE, VARIOUS SEATS, DISCS, AND SPRINGS ARE AVAILABLE AND EASY TO REPLACE. EXOTIC SPRING MATERIAL, SUCH AS MONEL OR INCONEL 750-X, CAN BE SUBSTITUTED EASILY FOR THE STANDARD STAINLESS STEEL.

TECHNICAL

PRESSURE/TEMPERATURE RATING ⁽¹⁾
CS - ASTM A216 GR. WCB - CLASS 300

WOG (Non-shock): 740 PSI @ 100 °F

PRESSURE/TEMPERATURE RATING ⁽¹⁾
SS - ASTM A351 GR. CF8M - CLASS 300

WOG (Non-shock): 720 PSI @ 100 °F

SEAT MATERIAL ⁽¹⁾
TEMPERATURE RANGE

STAINLESS STEEL: -325 ~ 1500 °F

SPRING MATERIAL ⁽¹⁾
MAXIMUM TEMPERATURE

STAINLESS STEEL: 450 °F

1. The above listed temperatures are theoretical and may vary during actual operating conditions.

APPLICATIONS

MARKETS: OIL AND GAS PRODUCTION, GENERAL INDUSTRY, CHEMICAL, PETROCHEMICAL, POWER, FOOD AND BEVERAGE

SERVICE: PUMP DISCHARGE SERVICE IN MUNICIPAL WATER, IRRIGATION, AND INDUSTRIAL CLASS HVAC SYSTEMS. IT IS RECOMMENDED THAT A TITAN FCI STRAINER BE INSTALLED AHEAD OF THE PUMP TO ENSURE PROTECTION OF THE CHECK VALVE AND THE PUMP.

PRECAUTIONS: THIS VALVE IS INTENDED FOR LIQUID SERVICE THAT DOES NOT EXCEED 10 FT/SEC. IT IS DESIGNED FOR STEADY FLOW CONDITIONS AND IS NOT RECOMMENDED FOR USE IN RECIPROCATING PUMP, COMPRESSOR OR OTHER TYPE OF PHYSICAL/THERMAL SHOCK-LOAD APPLICATIONS. THIS VALVE IS NOT RECOMMENDED FOR STEAM SERVICE OR FLOW MEDIA THAT CONTAINS SOLIDS. IT SHOULD BE INSTALLED AT LEAST FIVE PIPE DIAMETERS DOWNSTREAM FROM ANY TURBULENCE PRODUCING COMPONENTS. ADDITIONAL FLOW STRAIGHTENERS MAY BE REQUIRED IN CERTAIN APPLICATIONS.

The above data represents common market and service applications. No representation or guarantee, expressed or implied, is given due to the numerous variations of concentrations, temperatures and flow conditions that may occur during actual service.

TITAN FLOW CONTROL, INC.

YOUR PIPELINE TO THE FUTURE!

Tel: 910-735-0000 ♦ Fax: 910-738-3848 ♦ titan@titanfci.com ♦ www.titanfci.com
290 Corporate Drive ♦ PO Box 7408 ♦ Lumberton, NC 28358



TITAN FLOW CONTROL, Inc.

290 Corporate Drive
Lumberton, NC 28358
Tel: 910.735.0000

E-mail: titan@titanfci.com
Web: www.titanfci.com
Fax: 910.738.3848

SILENT CHECK VALVE • GLOBE TYPE
CV 52-CS (Carbon) CV 52-SS (Stainless Steel)

ANSI Class
300

Flanged Ends (RF) • Globe Style • Center Guided Disc

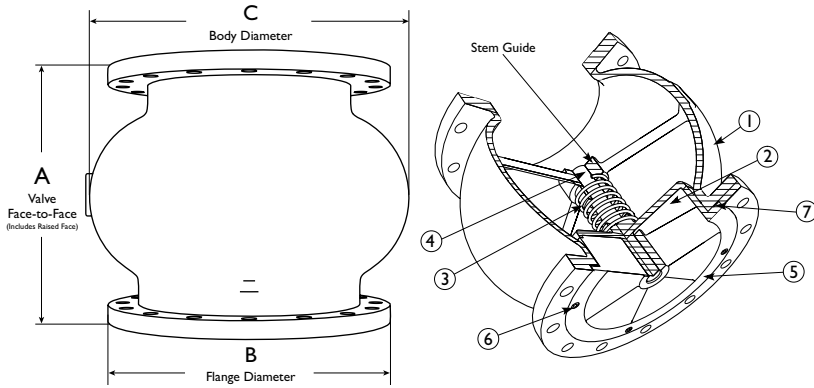

Additional Notes:

- Face-to-Face Dimension 'A' *includes* raised face. Class 300 flanges are regularly furnished with 1/16 inch high raised face.
- Carbon Steel bodies are epoxy painted. Other coatings are available, please contact factory for details.

BILL OF MATERIALS ⁽¹⁾

No.	PART	CV 52-CS	CV 52-SS
1	Body	Carbon Steel A216 Gr. WCB	Stainless Steel A351 Gr. CF8M Type 316
2	Disc ⁽²⁾	Stainless Steel Gr. CF8M Type 316	Stainless Steel A351 Gr. CF8M Type 316
3	Spring ⁽²⁾	Series 300 Stainless Steel	Series 300 Stainless Steel
4	Bushing ⁽²⁾	Stainless Steel	Stainless Steel
5	Seat ^{(2),(3)}	Stainless Steel A351 Gr. CF8M Type 316	Stainless Steel A351 Gr. CF8M Type 316
6	Cap Screw	Stainless Steel	Stainless Steel
7	Gasket ⁽²⁾	Non-asbestos Gasket	Non-asbestos Gasket

1. Bill of Materials represents standard materials. Equivalent or better materials may be substituted at the manufacturer's discretion.
2. Denotes recommended spare parts.
3. Resilient Seats are available upon request. Please call for details.

DIMENSIONS AND PERFORMANCE DATA ⁽¹⁾

SIZE ⁽²⁾	in	2	2 1/2	3	4	5	6	8	10	12	14
	mm	50	65	80	100	125	150	200	250	300	350
A DIMENSION FACE TO FACE ⁽³⁾	in	6.69	7.56	8.25	9.12	C/F	11.38	13.0	15.38	19.5	21.0
	mm	170	192	210	232	C/F	289	330	391	495	533
ØB DIMENSION FLANGE DIAMETER	in	6.50	7.50	8.25	10.0	C/F	12.5	15.0	17.5	20.5	23.0
	mm	165	191	210	254	C/F	318	381	445	521	584
ØC DIMENSION BODY DIAMETER	in	4.63	5.75	6.63	8.62	C/F	11.13	15.84	17.69	21.5	24.0
	mm	118	146	168	219	C/F	283	402	449	546	610
WEIGHT (APPROXIMATE)	lb	18.0	26.0	38.5	61.0	101.0	109.0	196.0	272.0	430.0	560.5
	kg	8.2	11.8	17.5	27.7	45.8	49.4	88.9	123.4	195.0	254.2
Flow Coefficient	C _v	65	105	150	265	410	600	1100	1800	2500	3100
Cracking Pressure ⁽⁴⁾	psi	≤ .5	≤ .5	≤ .5	≤ .5	≤ .5	≤ .5	≤ .5	≤ .5	≤ .5	≤ .5

1. Dimensions, weights, and flow coefficients are provided for reference only. When required, always request certified drawings.
2. Larger sizes are available. Please consult factory for these sizes and dimensions.
3. Face to face values have a tolerance of ±0.06 in (±2.0 mm) for sizes 10" and lower and a tolerance of ±0.12 in (±3.0 mm) for sizes 12" and larger.
4. Cracking pressure is for horizontal installations only. For vertical installations, please consult factory.

PRESSURE - TEMPERATURE RATINGS ⁽¹⁾

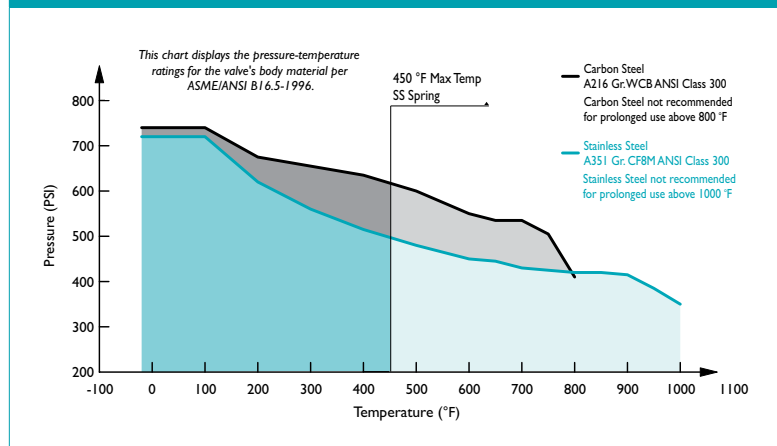

1. This chart displays the pressure-temperature ratings for the valve's body. Max temperature limits have been added for the spring material.

ORDERING CODE

Model Number	Description
CV52-CS	Carbon Steel Body, Stainless Steel Seat and Disc
CV52-SS	Stainless Steel Body, Stainless Steel Seat and Disc

REFERENCED STANDARDS & CODES

CODE	DESCRIPTION
ANSI B16.5	Pipe Flanges & Flanged Fittings
ANSI/API 594	Valve Design and Manufacture
API 598	Valve Inspection and Pressure Test
MSS SP-6	Standard Finishes for Connecting-end Flanges
MSS SP-25	Standard Marking System for Valves
MSS SP-55	Quality Standard for Valve Castings

PRESSURE - TEMPERATURE RATING

ANSI CLASS 300	Carbon Steel	Stainless Steel
WOG (Non-shock)	740 PSI @ 100 °F	720 PSI @ 100 °F

TEMPERATURE RANGE SEAT

SEAT	Temperature
Stainless Steel	-325 ~ 1500 °F

MAX TEMPERATURE SPRING

SPRING	Max Temperature
Stainless Steel	450 °F

The listed pressure and temperature ratings for the valve's body, seat, and spring are theoretical and may vary during actual operating conditions.

Titan FCI makes every effort to ensure the information presented on our literature accurately reflects exact product specifications. However, as product changes occur, there may be short-term differences between actual product specifications and the information contained within our literature. Titan FCI reserves the right to make design and specification changes to improve our products without prior notification. When required, request certified drawings.



TITAN FLOW CONTROL, INC.

CHECK VALVE ♦ WAFER TYPE ♦ DUAL DISC

ANSI CLASS 150 ♦ DUCTILE IRON BODY

MODEL: CV 41-DI

Body: Ductile Iron

Seats: Buna, Viton & EPDM

Discs: Stainless Steel & Aluminum Bronze

SIZES 2" ~ 6" PROVIDE
DUAL PRESSURE SERVICE
ANSI CLASS 150/300
(Scalloped Design)

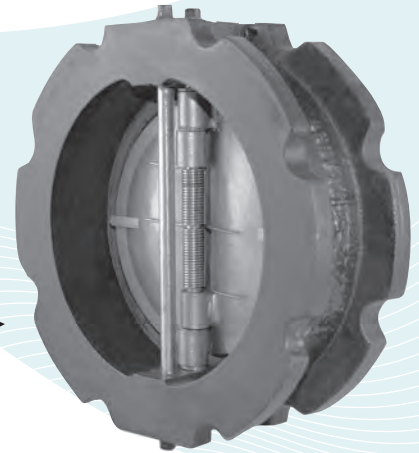

Sizes 2" ~ 12"

FEATURES

SIZES: 2" ~ 24"

LARGER SIZES AVAILABLE UPON REQUEST

- ♦ **COST EFFICIENT DESIGN**
LOW WEIGHT AND SHORT LAYING LENGTH PRODUCE SAVINGS IN INITIAL COST, SPACE REQUIREMENTS, AND INSTALLATION WHEN COMPARED TO FULL-BODY, SWING-TYPE CHECK VALVES.
- ♦ **MINIMAL HEAD LOSS**
CONTOUR OF BODY PROVIDES A SHORT AND STRAIGHT FLOW PATH THAT GENERATES VERY LITTLE TURBULENCE. ADDITIONALLY, THE SPRING-LOADED DISCS ARE DESIGNED WITH VERY LOW CRACKING PRESSURE WHICH REDUCES THE AMOUNT OF ENERGY REQUIRED TO OPEN THE VALVE.
- ♦ **QUICK CLOSURE TO REDUCE WATER HAMMER**
SHUT-OFF IS ACHIEVED VIA THE FULLY AUTOMATIC, SPRING-ASSISTED DISCS THAT CLOSE NEAR ZERO FLOW VELOCITY. THE LIGHTWEIGHT, SPLIT DISC DESIGN CREATES A POSITIVE SHUTOFF PRIOR TO FLOW REVERSAL AND HELPS TO KEEP SLAMMING AND SURGES TO A MINIMUM.
- ♦ **DUCTILE IRON BODY**
DUCTILE IRON BODY MAINTAINS THE ANTI-CORROSIVE PROPERTIES OF CAST IRON WHILE ACHIEVING A YIELD STRENGTH COMPARABLE TO CARBON STEEL. DUCTILE IRON ALSO OFFERS HIGHER PRESSURE/TEMPERATURE RATINGS THAN CAST IRON.
- ♦ **RESILIENT SOFT SEATS**
RESILIENT SOFT SEATS (EPDM, VITON OR BUNA) ENSURE A BUBBLE TIGHT SEAL THAT MEETS OR EXCEEDS API 598 TEST REQUIREMENTS.
- ♦ **VERSATILE DESIGN**
SIZES 2" THROUGH 6" ARE DESIGNED TO FIT BOLT CIRCLE PATTERNS FOR BOTH CAST IRON ANSI CLASSES 125/300 AND DUCTILE IRON ANSI CLASSES 150/300.

TECHNICAL

PRESSURE/TEMPERATURE RATING
DI - ASTM A536 - CLASS 150 - 2" ~ 24"

WOG (Non-shock): 250 PSI @ 100 °F

PRESSURE/TEMPERATURE RATING
DI - ASTM A536 - CLASS 300 - 2" ~ 6" only

WOG (Non-shock): 640 PSI @ 100 °F

SEAT MATERIAL
TEMPERATURE RANGE

EPDM: -20 ~ 300 °F
BUNA-N: -20 ~ 250 °F
VITON: -40 ~ 400 °F

SPRING MATERIAL
MAXIMUM TEMPERATURE

Series 300 Stainless Steel: 450 °F

APPLICATIONS

BUNA-N PROPERTIES: MOST WIDELY USED ELASTOMER. GOOD FOR MOST PETROLEUM OILS AND FLUIDS, SILICONE GREASES AND OILS, AND COLD WATER. EXCELLENT COMPRESSION SET, TEAR, AND ABRASION RESISTANCE. POOR WEATHER RESISTANCE AND MODERATE HEAT RESISTANCE. NOT RECOMMENDED FOR SEVERE OZONE-RESISTANT APPLICATIONS.

VITON PROPERTIES: OFFERS A BROAD RANGE OF CHEMICAL RESISTANCE AND EXCELLENT HEAT RESISTANCE. GOOD MECHANICAL PROPERTIES AND COMPRESSION SET RESISTANCE. OFTEN USED IN APPLICATIONS WHERE NOTHING ELSE WILL WORK. FAIR LOW TEMPERATURE RESISTANCE AND LIMITED HOT-WATER RESISTANCE AND SHRINKAGE.

EPDM PROPERTIES: PROBABLY THE MOST WATER RESISTANT RUBBER AVAILABLE. IT HAS GOOD RESISTANCE TO MILD ACIDS, ALKALIS, SILICONE OILS/GREASES, KETONES, ALCOHOLS AND OTHER POLAR SOLVENTS. IT IS NOT RECOMMENDED FOR USE WITH PETROLEUM OILS, DI-ESTER LUBRICANTS, MINERAL OILS, NON-POLAR SOLVENTS OR AROMATIC FUELS.

The above data represents common market and service applications. No representation or guarantee, expressed or implied, is given due to the numerous variations of concentrations, temperatures and flow conditions that may occur during actual service.

TITAN FLOW CONTROL, INC.

YOUR PIPELINE TO THE FUTURE!

Tel: 910-735-0000 ♦ Fax: 910-738-3848 ♦ titan@titanfci.com ♦ www.titanfci.com
290 Corporate Drive ♦ PO Box 7408 ♦ Lumberton, NC 28358



TITAN FLOW CONTROL, Inc.

290 Corporate Drive
Lumberton, NC 28358
Tel: 910.735.0000

E-mail: titan@titanfci.com
Web: www.titanfci.com
Fax: 910.738.3848

CHECK VALVE • WAFER TYPE • DUAL DISC

MODEL: CV 41-DI (Ductile Iron Body)

Buna-N, Viton, or EPDM Seats

Stainless Steel or Bronze Discs

ANSI
Class
150

BILL OF MATERIALS ⁽¹⁾

No.	PART	CV 41-DI ⁽²⁾
1	Body	Ductile Iron ASTM A536
2	Seat	Buna-N, Viton, or EPDM
3	Disc	Aluminum Bronze or Series 300 Stainless Steel
4	Spring ⁽²⁾	Series 300 Stainless Steel
5	Shaft/Stop Pin	Series 300 Stainless Steel
6	NPT Plug	Commercial Steel
7	Eye Bolt ⁽⁴⁾	Commercial Steel

1. Bill of Materials represents standard materials. Equivalent or better materials may be substituted at the manufacturer's discretion.
2. Denotes recommended spare parts.
3. Ductile Iron bodies are epoxy painted.
4. Eye Bolt is available on larger sizes only.

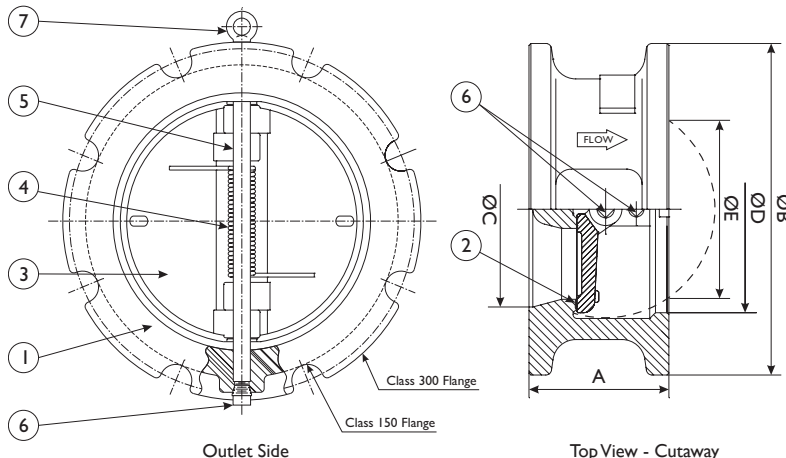

CAD illustration is representative of sizes 2" through 6". Sizes 8" through 24" are not scalloped. Sizes 2" through 6" are designed for dual pressure service (ANSI Class 150 and 300).

Ductile Iron Application Notes:

Ductile Iron maintains the anti-corrosive properties of Cast Iron while achieving a yield strength comparable to Carbon Steel. Ductile Iron also offers higher pressure/temperature ratings than Cast Iron. For example, Ductile Iron check valves (class 300 - sizes 2" ~ 24") are rated at 640 psi WOG. By comparison, Cast Iron check valves (class 250 - sizes 2" ~ 12") are rated at 500 psi WOG and (sizes 14" ~ 24") are only rated at 300 psi WOG. Ductile Iron ANSI Classes 150 and 300 have the same bolting pattern as Cast Iron ANSI Classes 125 and 250 respectively.

DIMENSIONS AND PERFORMANCE DATA ⁽¹⁾

SIZE	DIMENSIONS AND PERFORMANCE DATA ⁽¹⁾														
	in	2	2 1/2	3	4	5	6	8	10	12	14	16	18	20	24
	mm	50	65	80	100	125	150	200	250	300	350	400	450	500	600
A DIMENSION FACE TO FACE ⁽²⁾	in	2.12	2.12	2.25	2.50	2.75	3.00	3.75	4.25	5.62	7.25	7.50	8.00	8.37	8.75
	mm	54	54	58	64	70	77	96	108	143	185	191	204	213	223
ØB DIMENSION OUTLET OUTSIDE DIAMETER	in	4.37	5.12	5.75	7.12	8.50	9.87	11.00	13.37	16.12	17.75	20.25	21.62	23.87	28.25
	mm	111	131	146	181	216	251	280	340	410	451	515	550	607	718
ØC DIMENSION INLET INSIDE DIAMETER	in	2.00	2.50	3.00	4.00	5.00	6.00	8.00	10.00	12.00	14.00	16.00	18.00	20.00	24.00
	mm	51	64	77	102	127	153	204	254	305	356	407	458	508	610
ØD DIMENSION OUTLET INSIDE DIAMETER	in	2.62	3.12	3.87	4.75	6.00	7.00	9.00	11.00	13.25	14.25	16.25	18.12	20.12	24.00
	mm	67	80	98	121	152	178	229	280	337	362	413	461	512	610
ØE DIMENSION MINIMUM BORE DIAMETER	in	0	1.26	2.36	3.425	4.567	5.315	7.48	9.45	11.26	11.26	13.70	15.63	17.638	21.97
	mm	0	32	60	87	116	135	190	240	286	286	348	397	448	558
ASSEMBLED WEIGHT	lb	4.0	5.0	7.0	14.0	18.0	26.5	43.0	70.0	108.0	175.0	200.0	258.0	345.0	460.0
	kg	1.8	2.3	3.2	6.3	8.2	12.0	19.5	31.7	48.9	79.4	90.7	117.0	156.5	208.7
Flow Coefficient	C _v	62	110	175	350	550	850	1500	2400	3700	5400	8250	10400	14200	23000
Cracking Pressure ⁽³⁾	psi	≤ .25	≤ .25	≤ .25	≤ .25	≤ .25	≤ .25	≤ .25	≤ .25	≤ .25	≤ .25	≤ .25	≤ .25	≤ .25	≤ .25

1. Dimensions and weights are for reference only. When required, request certified drawings.
2. Face to face values have a tolerance of ±0.06 in (±2.0 mm) for sizes 10" and lower and a tolerance of ±0.12 in (±3.0 mm) for sizes 12" and larger.
3. Cracking pressure is for horizontal installations only. For vertical installations, please consult factory.

PRESSURE - TEMPERATURE RATINGS ⁽¹⁾

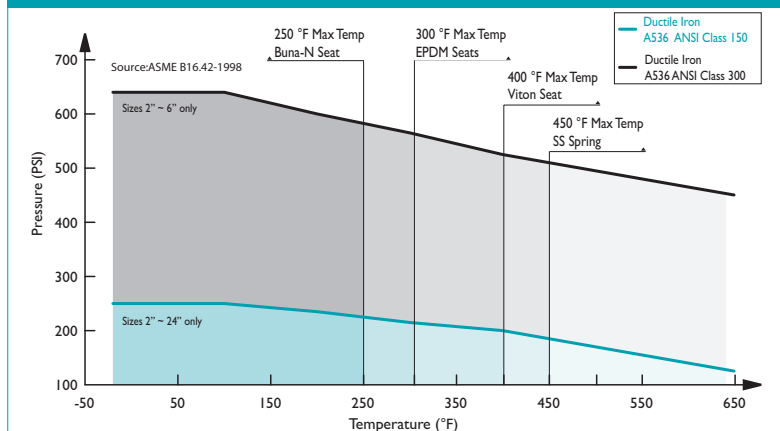

1. The above chart displays the pressure-temperature ratings for the valve's body material per ASME B16.42-1998. Max temperature limits have been added for seat and spring materials. Sizes 2" through 6" are dual pressure rated for both ANSI Class 150 and 300.

Titan FCI makes every effort to ensure the information presented on our literature accurately reflects exact product specifications. However, as product changes occur, there may be short-term differences between actual product specifications and the information contained within our literature. Titan FCI reserves the right to make design and specification changes to improve our products without prior notification. When required, request certified drawings.

REFERENCED STANDARDS & CODES

CODE	DESCRIPTION
ANSI/API 594	Valve Design and Manufacture
ASME/ANSI 16.5	Flange Dimensions
ASME/ANSI B16.34	Valves - Flanged, Threaded, and Welding End
ASME/ANSI B16.42	Ductile Iron Pipe Flanges and Flanged Fittings
API 598	Valve Inspection and Pressure Test
FM APPROVALS CLASS 1230	Anti-Water Hammer Check Valves (2" ~ 12")

PRESSURE / TEMPERATURE RATING - ASTM A536

Body Material	Class 150 (2" ~ 24")	Class 300 (2" ~ 6")
WOG (Non-shock):	250 PSI @ 100 °F	640 PSI @ 100 °F

SEAT AND SPRING TEMPERATURE RATING

Seat Material	Range	Spring Material	Max
EPDM:	-30 ~ 300 °F	Series 300 Stainless Steel:	450 °F
BUNA-N:	-20 ~ 250 °F		
VITON:	-40 ~ 400 °F		



TITAN FLOW CONTROL, INC.

CHECKVALVE ♦ WAFER TYPE ♦ DUAL DISC

ASME CLASS 150 ♦ DUCTILE IRON BODY ♦ NSF COATING

MODEL: CV 41A-DI

Body: Ductile Iron

Seats: Buna, Viton & EPDM

Discs: Stainless Steel & Aluminum Bronze

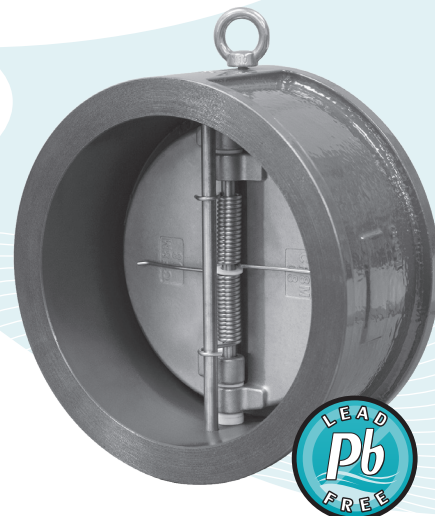
NEWLY
DESIGNED...
Meets API 594

FEATURES

SIZES: 2" ~ 24"

LARGER SIZES AVAILABLE
UPON REQUEST

♦ COMPLIES WITH API 594 DIMENSIONS

THE CV41A-DI MEETS API 594 ASME CLASS 125 FACE-TO-FACE DIMENSIONS. THIS ALLOWS THE CV41A-DI TO BE A NATURAL REPLACEMENT FOR OUTDATED CAST IRON VALVES WHILE ACHIEVING THE SUPERIOR MATERIAL BENEFITS OF DUCTILE IRON.

♦ NSF APPROVED COATING

THE BODY OF THIS VALVE IS COATED WITH TNEMEC SERIES 141 EPOXOLINE. THIS COATING OFFERS HIGH-BUILD EDGE PROTECTION AND EXCELLENT CORROSION RESISTANCE. THIS COATING IS CERTIFIED BY NSF INTERNATIONAL IN ACCORDANCE WITH NSF/ANSI STANDARD 61.

♦ DUCTILE IRON BODY

DUCTILE IRON BODY MAINTAINS THE ANTI-CORROSIVE PROPERTIES OF CAST IRON WHILE ACHIEVING A YIELD STRENGTH COMPARABLE TO CARBON STEEL. DUCTILE IRON ALSO OFFERS HIGHER PRESSURE/TEMPERATURE RATINGS THAN CAST IRON.

♦ COST EFFICIENT DESIGN

LOW WEIGHT AND SHORT LAYING LENGTH PRODUCE SAVINGS IN INITIAL COST, SPACE REQUIREMENTS, AND INSTALLATION WHEN COMPARED TO FULL-BODY, SWING-TYPE CHECK VALVES.

♦ MINIMAL HEAD LOSS

CONTOUR OF BODY PROVIDES A SHORT AND STRAIGHT FLOW PATH THAT GENERATES VERY LITTLE TURBULENCE. ADDITIONALLY, THE SPRING-LOADED DISCS ARE DESIGNED WITH VERY LOW CRACKING PRESSURE WHICH REDUCES THE AMOUNT OF ENERGY REQUIRED TO OPEN THE VALVE.

♦ QUICK CLOSURE TO REDUCE WATER HAMMER

SHUT-OFF IS ACHIEVED VIA THE FULLY AUTOMATIC, SPRING-ASSISTED DISCS THAT CLOSE NEAR ZERO FLOW VELOCITY. THE LIGHTWEIGHT, SPLIT DISC DESIGN CREATES A POSITIVE SHUTOFF PRIOR TO FLOW REVERSAL AND HELPS TO KEEP SLAMMING AND SURGES TO A MINIMUM.

TECHNICAL

PRESSURE/TEMPERATURE RATING
DI - ASTM A536 - CLASS 150 - 2" ~ 24"

WOG (Non-shock): 250 PSI @ 100 °F

SEAT MATERIAL
TEMPERATURE RANGEEPDM: -20 ~ 300 °F
BUNA-N: -20 ~ 250 °F
VITON: -40 ~ 400 °FSPRING MATERIAL
MAXIMUM TEMPERATURE

SS ASTM A182 Gr. 316: 450 °F

CV 41A meets AWWA C518 Face-to-Face Dimensions.

APPLICATIONS

BUNA-N PROPERTIES: MOST WIDELY USED ELASTOMER. GOOD FOR MOST PETROLEUM OILS AND FLUIDS, SILICONE GREASES AND OILS, AND COLD WATER. EXCELLENT COMPRESSION SET, TEAR, AND ABRASION RESISTANCE. POOR WEATHER RESISTANCE AND MODERATE HEAT RESISTANCE. NOT RECOMMENDED FOR SEVERE OZONE-RESISTANT APPLICATIONS.

VITON PROPERTIES: OFFERS A BROAD RANGE OF CHEMICAL RESISTANCE AND EXCELLENT HEAT RESISTANCE. GOOD MECHANICAL PROPERTIES AND COMPRESSION SET RESISTANCE. OFTEN USED IN APPLICATIONS WHERE NOTHING ELSE WILL WORK. FAIR LOW TEMPERATURE RESISTANCE AND LIMITED HOT-WATER RESISTANCE AND SHRINKAGE.

EPDM PROPERTIES: PROBABLY THE MOST WATER RESISTANT RUBBER AVAILABLE. IT HAS GOOD RESISTANCE TO MILD ACIDS, ALKALIS, SILICONE OILS/GREASES, KETONES, ALCOHOLS AND OTHER POLAR SOLVENTS. IT IS NOT RECOMMENDED FOR USE WITH PETROLEUM OILS, DI-ESTER LUBRICANTS, MINERAL OILS, NON-POLAR SOLVENTS OR AROMATIC FUELS.

The above data represents common market and service applications. No representation or guarantee, expressed or implied, is given due to the numerous variations of concentrations, temperatures and flow conditions that may occur during actual service.

TITAN FLOW CONTROL, INC.
YOUR PIPELINE TO THE FUTURE!

Tel: 910-735-0000 ♦ Fax: 910-738-3848 ♦ titan@titanfci.com ♦ www.titanfci.com
290 Corporate Drive ♦ PO Box 7408 ♦ Lumberton, NC 28358



TITAN FLOW CONTROL, Inc.

290 Corporate Drive
Lumberton, NC 28358
Tel: 910.735.0000

E-mail: titan@titanfci.com
Web: www.titanfci.com
Fax: 910.738.3848

CHECK VALVE • WAFER TYPE • DUAL DISC

MODEL: CV 41A-DI (Ductile Iron Body)

Buna-N, Viton, or EPDM Seats
Stainless Steel or Bronze Discs

ASME
Class
150

BILL OF MATERIALS (1)

No.	PART	CV 41A-DI (2)
1	Body	Ductile Iron ASTM A536
2	Seat	Buna-N/Viton/EPDM
3	Disc (2)	Aluminum Bronze ASTM B148 / Stainless Steel ASTM A351 Gr. CF8M
4	Spring (2)	Stainless Steel ASTM A182 Gr. 316
5	Shaft/Stop Pin	Stainless Steel ASTM A182 Gr. 316
6	Set Screw	Galvanized Carbon Steel
7	Eye Bolt (4)	Carbon Steel (Not Shown)
8	Seal Plug	Buna-N/Viton/EPDM

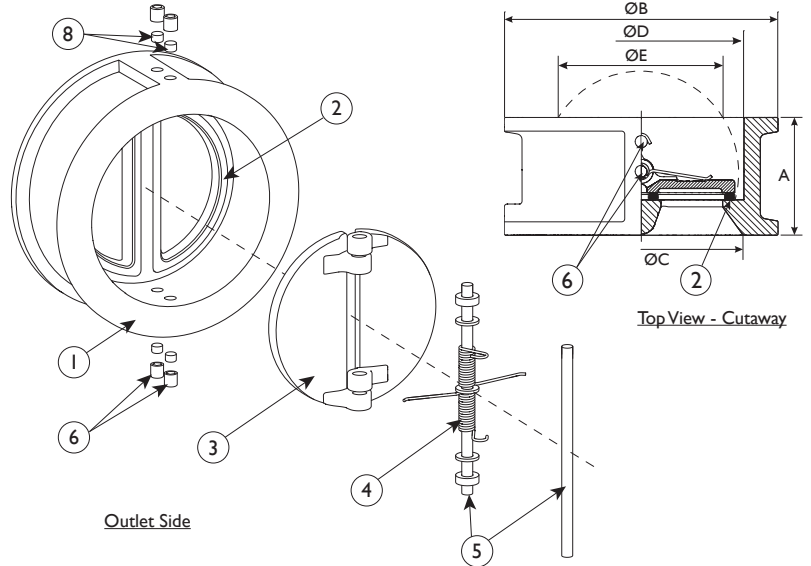

1. Bill of Materials represents standard materials. Equivalent or better materials may be substituted at the manufacturer's discretion.
2. Denotes recommended spare parts.
3. Ductile Iron bodies are NSF coated.
4. Eye Bolt is available on larger sizes only.

Ductile Iron Application Notes:

Ductile Iron maintains the anti-corrosive properties of Cast Iron while achieving a yield strength comparable to Carbon Steel. Ductile Iron also offers higher pressure/temperature ratings than Cast Iron. Ductile Iron ASME Class 150 has the same bolting pattern as Cast Iron ASME Class 125.

DIMENSIONS AND PERFORMANCE DATA (1)

SIZE	in	2	2 1/2	3	4	5	6	8	10	12	14	16	18	20	24
	mm	50	65	80	100	125	150	200	250	300	350	400	450	500	600
A DIMENSION FACE TO FACE (2)	in	2.12	2.38	2.62	2.62	3.25	3.75	5.00	5.50	7.12	7.25	7.50	8.00	8.38	8.75
	mm	54	60	67	67	83	95	127	140	181	184	191	203	213	222
ØB DIMENSION OUTLET OUTSIDE DIAMETER	in	4.02	4.76	5.24	6.73	7.60	8.62	10.87	13.23	15.98	17.64	20.12	21.50	23.74	28.11
	mm	102	121	133	171	193	219	276	336	406	448	511	546	603	714
ØC DIMENSION INLET INSIDE DIAMETER	in	2.17	2.92	3.45	4.12	5.67	6.43	8.56	10.43	12.21	14.17	16.13	17.32	20.10	23.66
	mm	55	74	88	105	144	163	217	265	310	360	410	440	511	601
ØD DIMENSION OUTLET INSIDE DIAMETER	in	2.58	3.15	3.70	4.61	5.71	6.69	8.82	10.43	12.20	14.17	16.14	17.72	19.88	24.57
	mm	66	80	94	117	145	170	224	265	310	360	410	450	505	624
ØE DIMENSION MINIMUM BORE DIAMETER	in	1.66	2.28	2.78	3.38	4.53	5.49	7.40	9.14	10.65	12.97	14.63	16.26	18.17	22.62
	mm	42	58	71	86	115	140	188	232	271	330	372	413	462	575
ASSEMBLED WEIGHT	lb	3.3	5.2	7.0	14.0	18.0	26.5	43.0	70.0	108.0	175.0	200.0	258.0	345.0	460.0
	kg	1.5	2.4	3.2	6.4	8.2	12.0	19.5	31.7	48.9	79.4	90.7	117.0	156.5	208.7
Flow Coefficient	C _v	62	110	175	350	550	850	1500	2400	3700	5400	8250	10400	14200	23000
Cracking Pressure (3)	psi	≤ .25	≤ .25	≤ .25	≤ .25	≤ .25	≤ .25	≤ .25	≤ .25	≤ .25	≤ .25	≤ .25	≤ .25	≤ .25	≤ .25

1. Dimensions and weights are for reference only. When required, request certified drawings.
2. Face to face values have a tolerance of ±0.06 in (±2.0 mm) for sizes 10" and lower and a tolerance of ±0.12 in (±3.0 mm) for sizes 12" and larger.

3. Cracking pressure is for horizontal installations only. For vertical installations, please consult factory.

REFERENCED STANDARDS & CODES

CODE	DESCRIPTION
API 594	Valve Design and Manufacture
AWWA C518	Face-to-Face Dimensions
ASME B16.34	Valves - Flanged, Threaded, and Welding End
ASME B16.42	Ductile Iron Pipe Flanges and Flanged Fittings
API 598	Valve Inspection and Pressure Test

PRESSURE / TEMPERATURE RATING - ASTM A536

Body Material	Class 150 (2" ~ 24")
WOG (Non-shock):	250 PSI @ 100 °F

SEAT AND SPRING TEMPERATURE RATING

Seat Material	Range	Spring Material	Max
EPDM:	-30 ~ 300 °F	SS ASTM A182 Gr. 316:	450 °F
BUNA-N:	-20 ~ 250 °F		
VITON:	-40 ~ 400 °F		

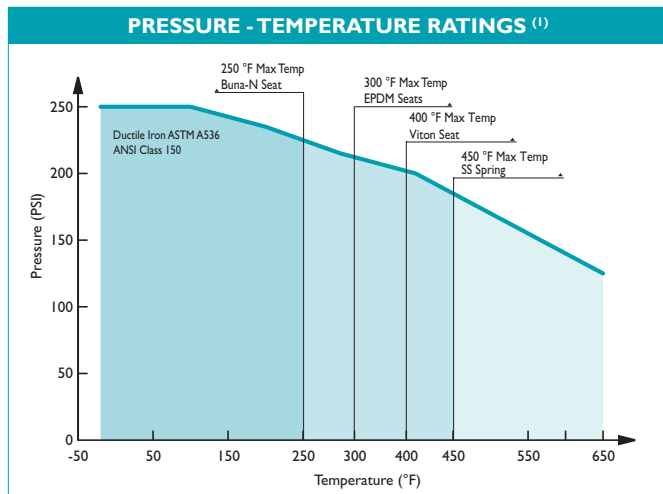

1. The above chart displays the pressure-temperature ratings for the valve's body material per ASME B16.42. Max temperature limits have been added for seat and spring materials.

Titan FCI makes every effort to ensure the information presented on our literature accurately reflects exact product specifications. However, as product changes occur, there may be short-term differences between actual product specifications and the information contained within our literature. Titan FCI reserves the right to make design and specification changes to improve our products without prior notification. When required, request certified drawings.



TITAN FLOW CONTROL, INC.

CHECK VALVE ♦ WAFER AND LUG STYLES ♦ DUAL DISC

ANSI CLASS 150 ♦ CARBON AND STAINLESS STEEL

MODELS:

CV 42-CS
(CARBON STEEL - WAFER)

CV 42L-CS
(CARBON STEEL - LUG)

CV 42-SS
(STAINLESS STEEL - WAFER)

CV 42L-SS
(STAINLESS STEEL - LUG)

SIZES: 2" ~ 24"

WAFER STYLES 2" ~ 6" PROVIDE DUAL
PRESSURE SERVICE (ANSI CLASS 150/300)
LUG STYLES ARE BLIND TAPPED AS STANDARD



Now
Available
in Lug
Styles!

4" CV 42-SS

8" CV 42L-CS

FEATURES

- ♦ **AVAILABLE IN WAFER AND LUG STYLES**
THIS LOW WEIGHT AND SHORT LAYING DESIGN IS NOW AVAILABLE IN BOTH LUG AND WAFER STYLES. LUG STYLES, THREADED ON BOTH SIDES OF THE BODY, CAN BE USED AS A BLOCK VALVE FOR THE PIPELINE.
- ♦ **MINIMAL HEAD LOSS**
CONTOUR OF BODY PROVIDES A SHORT AND STRAIGHT FLOW PATH THAT GENERATES VERY LITTLE TURBULENCE. ADDITIONALLY, THE SPRING-LOADED DISCS ARE DESIGNED WITH VERY LOW CRACKING PRESSURE WHICH REDUCES THE AMOUNT OF ENERGY REQUIRED TO OPEN THE VALVE.
- ♦ **QUICK CLOSURE TO REDUCE WATER HAMMER**
SHUT-OFF IS ACHIEVED VIA THE FULLY AUTOMATIC, SPRING-ASSISTED DISCS THAT CLOSE NEAR ZERO FLOW VELOCITY. THE LIGHTWEIGHT, SPLIT DISC DESIGN CREATES A POSITIVE SHUTOFF PRIOR TO FLOW REVERSAL AND HELPS TO KEEP SLAMMING AND SURGES TO A MINIMUM.
- ♦ **DESIGNED FOR LONG SERVICE LIFE**
THE SPRING AND DISCS ARE DESIGNED TO ALLOW THE DISCS TO LIFT LINEARLY BEFORE PIVOTING TO AVOID THE DISC HEAL FROM SCRUBBING THE SEALING SURFACE. ALSO, DISCS ARE EQUIPPED WITH CAST-IN SHOCK BUMPERS THAT HELP TO REDUCE WEAR AND TEAR ON INTERNAL COMPONENTS.
- ♦ **FUGITIVE EMISSION DESIGN**
THE RETAINER-LESS BODY DESIGN ELIMINATES POTENTIAL LEAK PATHS TO THE ENVIRONMENT SO THERE ARE NO BODY EMISSIONS.
- ♦ **RESILIENT AND METAL SEATS**
BOARD, LAPPED SEALING SURFACE (METAL) MEETS OR EXCEEDS API 598 TEST REQUIREMENTS. RESILIENT SEATS (VITON/BUNA) ENSURE A BUBBLE TIGHT SEAL.

TECHNICAL

PRESSURE/TEMPERATURE RATING
CS - ASTM A216 GR. WCB - CLASS 150

WOG (Non-shock): 285 PSI @ 100 °F

PRESSURE/TEMPERATURE RATING
SS - ASTM A351 GR. CF8M - CLASS 150

WOG (Non-shock): 275 PSI @ 100 °F

SEAT MATERIAL
TEMPERATURE RANGE

VITON: -40 ~ 400 °F
BUNA-N: -20 ~ 250 °F

SPRING MATERIAL
TEMPERATURE MAXIMUM

INCONEL X-750: 1000 °F

The above listed temperatures are theoretical and may vary during actual operating conditions.

APPLICATIONS

MARKETS: WATER & WASTEWATER, PULP & PAPER, CHEMICAL & PETROCHEMICAL, POWER, PETROLEUM AND OIL & GAS

BUNA-N PROPERTIES: MOST WIDELY USED ELASTOMER. GOOD FOR MOST PETROLEUM OILS AND FLUIDS, SILICONE GREASES AND OILS, AND COLD WATER. EXCELLENT COMPRESSION SET, TEAR, AND ABRASION RESISTANCE. POOR WEATHER RESISTANCE AND MODERATE HEAT RESISTANCE. NOT RECOMMENDED FOR SEVERE OZONE-RESISTANT APPLICATIONS.

VITON PROPERTIES: OFFERS A BROAD RANGE OF CHEMICAL RESISTANCE AND EXCELLENT HEAT RESISTANCE. GOOD MECHANICAL PROPERTIES AND COMPRESSION SET RESISTANCE. OFTEN USED IN APPLICATIONS WHERE NOTHING ELSE WILL WORK. FAIR LOW TEMPERATURE RESISTANCE AND LIMITED HOT-WATER RESISTANCE AND SHRINKAGE.

The above data represents common market and service applications. No representation or guarantee, expressed or implied, is given due to the numerous variations of concentrations, temperatures and flow conditions that may occur during actual service.

TITAN FLOW CONTROL, INC.
YOUR PIPELINE TO THE FUTURE!

Tel: 910-735-0000 ♦ Fax: 910-738-3848 ♦ titan@titanfci.com ♦ www.titanfci.com
290 Corporate Drive ♦ PO Box 7408 ♦ Lumberton, NC 28358



TITAN FLOW CONTROL, Inc.

290 Corporate Drive
Lumberton, NC 28358
Tel: 910.735.0000

E-mail: titan@titanfci.com
Web: www.titanfci.com
Fax: 910.738.3848

CHECK VALVE • WAFER & LUG • DUAL DISC

Wafer-Style
CV 42-CS (Carbon Steel)
CV 42-SS (Stainless Steel)

Lug-Style
CV 42L-CS (Carbon Steel)
CV 42L-SS (Stainless Steel)

ANSI Class
150

BILL OF MATERIALS (1)

No.	PART	CV42/CV42L-CS	CV42/CV42L-SS
1	Body	Carbon Steel A216 Gr.WCB	Stainless Steel A351 Gr. CF8M
2	Seat	Metal/Viton/Buna-N (4)	Metal or Viton
3	Disc (2)	Stainless Steel A351 Gr. CF8M	Stainless Steel A351 Gr. CF8M
4	Spring (2)	Inconel X-750	Inconel X-750
5	Shaft/Stop Pin	Stainless Steel A276 Gr. 316	Stainless Steel A276 Gr. 316
6	Cap	Carbon Steel ASTMA 105	Stainless Steel A351 Gr. CF8M
7	Eye Bolt (3)	Carbon Steel	Carbon Steel

1. Bill of Materials represents standard materials. Equivalent or better materials may be substituted at the manufacturer's discretion.
2. Denotes recommended spare parts.
3. Part #7, Eye Bolt, is only on Sizes 8" and up.
4. Metal seat is stainless steel.

Additional Design & Technical Notes:

- The CV42 and CV42L have a fugitive emission design. The retainer-less body design eliminates potential leak paths to the environment so there are no body emissions.

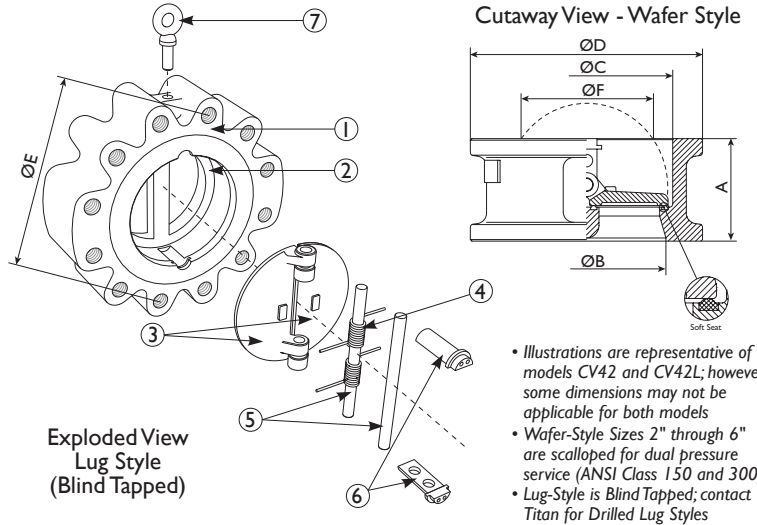

- Illustrations are representative of models CV42 and CV42L; however, some dimensions may not be applicable for both models
- Wafer-Style Sizes 2" through 6" are scalloped for dual pressure service (ANSI Class 150 and 300)
- Lug-Style is Blind Tapped; contact Titan for Drilled Lug Styles

DIMENSIONS AND PERFORMANCE DATA (1)

SIZE		2	2 1/2	3	4	5	6	8	10	12	14	16	18	20	24
		mm	50	65	80	100	125	150	200	250	300	350	400	450	500
A DIMENSION FACE TO FACE (2)	in	2.38	2.62	2.88	2.88	3.38	3.87	5.00	5.75	7.12	7.25	7.50	8.00	8.62	8.75
	mm	60	67	73	73	86	99	127	146	181	184	191	203	219	222
ØB DIMENSION INLET DIAMETER	in	2.00	2.50	3.00	4.00	5.00	6.52	8.00	10.00	12.00	13.26	15.24	17.24	19.50	23.42
	mm	51	64	76	102	127	166	203	254	305	337	387	438	495	595
ØC DIMENSION OUTLET DIAMETER	in	2.16	2.67	3.23	4.25	5.12	6.38	8.66	10.63	12.60	13.78	15.75	17.24	19.50	23.42
	mm	55	68	82	108	130	162	220	270	320	350	400	438	495	595
ØD DIMENSION OVERALL DIAMETER	in	4.33	5.04	5.31	7.05	8.43	9.81	10.91	13.27	16.02	17.64	20.15	21.54	23.78	28.15
	mm	110	128	147	179	214	249	277	337	407	448	512	547	604	715
ASSEMBLED WEIGHT (Wafer)	lb	5.5	8.0	10.0	15.5	23.5	36.0	51.5	88.0	131.0	178.0	242.0	276.0	362.0	462.0
	kg	2.5	3.6	4.5	7.0	10.6	16.3	23.3	39.9	59.4	80.7	109.7	125.1	164.2	209.6
ØE DIMENSION BOLT CIRCLE DIAMETER	in	4.75	5.5	6.0	7.5	8.5	9.5	11.75	14.25	17.0	C/F	21.25	C/F	25.0	29.5
	mm	121	140	152	191	216	241	298	362	432	C/F	540	C/F	635	749
NO. OF BOLTS	qty	4	4	4	8	8	8	8	12	12	C/F	16	C/F	20	20
	BOLT SIZE	in-UNC	5/8-11	5/8-11	5/8-11	5/8-11	3/4-10	3/4-10	3/4-10	7/8-9	7/8-9	C/F	1-8	C/F	1 1/8-8
ASSEMBLED WEIGHT (Lug)	lb	8.0	C/F	16.0	28.0	C/F	50.0	95.0	150.0	242.0	C/F	C/F	C/F	C/F	C/F
	kg	3.6	C/F	7.3	12.7	C/F	22.7	43.1	68.0	109.8	C/F	C/F	C/F	C/F	C/F
ØF DIMENSION MINIMUM BORE DIAMETER(4)	in	.94	1.69	2.36	3.54	4.45	5.31	7.13	8.82	10.47	11.81	14.29	15.87	18.03	22.28
	mm	24	43	60	90	113	135	181	224	266	300	363	403	458	566
Flow Coefficient	C _v	62	110	175	350	550	850	1500	2400	3700	5400	8250	10400	14200	23000
Cracking Pressure (3)	psi	≤ .25	≤ .25	≤ .25	≤ .25	≤ .25	≤ .25	≤ .25	≤ .25	≤ .25	≤ .25	≤ .25	≤ .25	≤ .25	≤ .25

1. Dimensions and weights are for reference only. When required, request certified drawings.
2. Face to face values have a tolerance of ±0.06 in (±2.0 mm) for sizes 10" and lower and a tolerance of ±0.12 in (±3.0 mm) for sizes 12" and larger.
3. Cracking pressure is for horizontal installations only. For vertical installations, please consult factory.
4. Minimum Bore Diameter indicates the minimum internal diameter of the adjacent pipe.

PRESSURE - TEMPERATURE RATINGS (1)

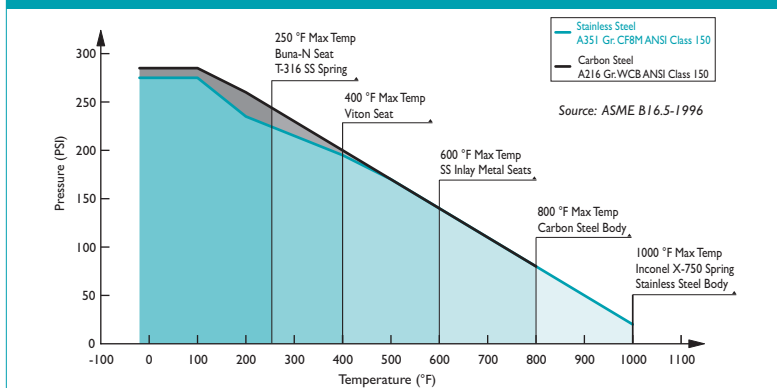

1. The above chart displays the pressure-temperature ratings for the valve's body material per ASME B16.5-1996. Max temperature limits have been added for seat and spring materials. For ANSI Class 300 ratings (Wafer-Style 2" ~ 6"), please refer to the CV 44-CC/SS specification sheet.

Titan FCI makes every effort to ensure the information presented on our literature accurately reflects exact product specifications. However, as product changes occur, there may be short-term differences between actual product specifications and the information contained within our literature. Titan FCI reserves the right to make design and specification changes to improve our products without prior notification. When required, request certified drawings.

REFERENCED STANDARDS & CODES

CODE	DESCRIPTION
ANSI/API 594	Valve Design and Manufacture
ANSI/ASME 16.5	Flange Dimensions
ANSI/API 594	Valve Face to Face Dimensions
API 598	Valve Inspection and Pressure Test

PRESSURE - TEMPERATURE RATING

Body Material	A216 Gr. WCB	A351 Gr. CF8M
WOG (Non-shock):	285 PSI @ 100 °F	275 PSI @ 100 °F

Wafer-Style Sizes 2" through 6" are designed for dual pressure service (Class 150 and 300). For ANSI Class 300 ratings, please refer to the CV 44-CC/SS specification sheet.

SEAT AND SPRING TEMPERATURE RATING

Seat Material	Range	Spring Material	Max
VITON:	-40 ~ 400 °F	INCONEL X-750:	1000 °F
BUNA-N:	-20 ~ 250 °F	T-316 SS:	450 °F



TITAN FLOW CONTROL, INC.

CHECK VALVE ♦ WAFER TYPE ♦ DUAL DISC

ANSI CLASS 300 ♦ CARBON AND STAINLESS STEEL

MODELS: CV 44-CS
(CARBON STEEL)

CV 44-SS
(STAINLESS STEEL)

SIZES: 2" ~ 24"



2" ~ 6" PROVIDE DUAL PRESSURE
SERVICE (ANSI CLASS 150/300)

FEATURES

- ♦ **COST EFFICIENT DESIGN**
LOW WEIGHT AND SHORT LAYING LENGTH PRODUCE SAVINGS IN INITIAL COST, SPACE REQUIREMENTS, AND INSTALLATION WHEN COMPARED TO FULL-BODY, SWING-TYPE CHECK VALVES.
- ♦ **MINIMAL HEAD LOSS**
CONTOUR OF BODY PROVIDES A SHORT AND STRAIGHT FLOW PATH THAT GENERATES VERY LITTLE TURBULENCE. ADDITIONALLY, THE SPRING-LOADED DISCS ARE DESIGNED WITH VERY LOW CRACKING PRESSURE WHICH REDUCES THE AMOUNT OF ENERGY REQUIRED TO OPEN THE VALVE.
- ♦ **QUICK CLOSURE TO REDUCE WATER HAMMER**
SHUT-OFF IS ACHIEVED VIA THE FULLY AUTOMATIC, SPRING-ASSISTED DISCS THAT CLOSE NEAR ZERO FLOW VELOCITY. THE LIGHTWEIGHT, SPLIT DISC DESIGN CREATES A POSITIVE SHUTOFF PRIOR TO FLOW REVERSAL AND HELPS TO KEEP SLAMMING AND SURGES TO A MINIMUM.
- ♦ **DESIGNED FOR LONG SERVICE LIFE**
THE SPRING AND DISCS ARE DESIGNED TO ALLOW THE DISCS TO LIFT LINEARLY BEFORE PIVOTING TO AVOID THE DISC HEEL FROM SCRUBBING THE SEALING SURFACE. ALSO, DISCS ARE EQUIPPED WITH CAST-IN SHOCK BUMPERS THAT HELP TO REDUCE WEAR AND TEAR ON INTERNAL COMPONENTS.
- ♦ **FUGITIVE EMISSION DESIGN**
THE RETAINER-LESS BODY DESIGN ELIMINATES POTENTIAL LEAK PATHS TO THE ENVIRONMENT SO THERE ARE NO BODY EMISSIONS.
- ♦ **RESILIENT AND METAL SEATS**
BOARD, LAPPED SEALING SURFACE (METAL) MEETS OR EXCEEDS API 598 TEST REQUIREMENTS. RESILIENT SEATS (VITON/BUNA) ENSURE A BUBBLE TIGHT SEAL.

TECHNICAL

PRESSURE/TEMPERATURE RATING
CS - ASTM A216 GR. WCB - CLASS 300

WOG (Non-shock): 740 PSI @ 100 °F

PRESSURE/TEMPERATURE RATING
SS - ASTM A351 GR. CF8M - CLASS 300

WOG (Non-shock): 720 PSI @ 100 °F

SEAT MATERIAL
TEMPERATURE RANGE

VITON: -40 ~ 400 °F
BUNA-N: -20 ~ 250 °F

SPRING MATERIAL ⁽¹⁾
TEMPERATURE MAXIMUM

INCONEL X-750: 1000 °F

1. The above listed temperatures are theoretical and may vary during actual operating conditions.

APPLICATIONS

MARKETS: WATER & WASTEWATER, PULP & PAPER, CHEMICAL & PETROCHEMICAL, POWER, PETROLEUM AND OIL & GAS

BUNA-N PROPERTIES: MOST WIDELY USED ELASTOMER. GOOD FOR MOST PETROLEUM OILS AND FLUIDS, SILICONE GREASES AND OILS, AND COLD WATER. EXCELLENT COMPRESSION SET, TEAR, AND ABRASION RESISTANCE. POOR WEATHER RESISTANCE AND MODERATE HEAT RESISTANCE. NOT RECOMMENDED FOR SEVERE OZONE-RESISTANT APPLICATIONS.

VITON PROPERTIES: OFFERS A BROAD RANGE OF CHEMICAL RESISTANCE AND EXCELLENT HEAT RESISTANCE. GOOD MECHANICAL PROPERTIES AND COMPRESSION SET RESISTANCE. OFTEN USED IN APPLICATIONS WHERE NOTHING ELSE WILL WORK. FAIR LOW TEMPERATURE RESISTANCE AND LIMITED HOT-WATER RESISTANCE AND SHRINKAGE.

The above data represents common market and service applications. No representation or guarantee, expressed or implied, is given due to the numerous variations of concentrations, temperatures and flow conditions that may occur during actual service.

TITAN FLOW CONTROL, INC.

YOUR PIPELINE TO THE FUTURE!

Tel: 910-735-0000 ♦ Fax: 910-738-3848 ♦ titan@titanfci.com ♦ www.titanfci.com
290 Corporate Drive ♦ PO Box 7408 ♦ Lumberton, NC 28358



TITAN FLOW CONTROL, Inc.
 290 Corporate Drive
 Lumberton, NC 28358
 Tel: 910.735.0000
 E-mail: titan@titanfci.com
 Web: www.titanfci.com
 Fax: 910.738.3848

CHECKVALVE • WAFERTYPE • DUAL DISC
MODELS: CV 44-CS (Carbon Steel)
CV 44-SS (Stainless Steel)

ANSI Class
 300

BILL OF MATERIALS ⁽¹⁾

No.	PART	CV 44-CS ⁽³⁾	CV 44-SS
1	Body	Carbon Steel A216 Gr.WCB	Stainless Steel A351 Gr. CF8M
2	Seat	Metal/Viton/Buna-N ⁽⁴⁾	Metal or Viton
3	Disc ⁽²⁾	Stainless Steel A351 Gr. CF8M	Stainless Steel A351 Gr. CF8M
4	Spring ⁽²⁾	Inconel X-750	Inconel X-750
5	Shaft/Stop Pin	Stainless Steel A276 Gr. 316	Stainless Steel A276 Gr. 316
6	Pin Cap	Carbon Steel ASTMA105	Stainless Steel A276 Gr. 316

1. Equivalent or better materials may be substituted at the manufacturer's discretion.
2. Denotes recommended spare parts.
3. Carbon Steel bodies are epoxy painted.
4. Metal seat is stainless steel.

Additional Design & Technical Notes:

- The CV 44 has a fugitive emission design. This retainer-less body design eliminates potential leak paths to the environment so there are no body emissions.

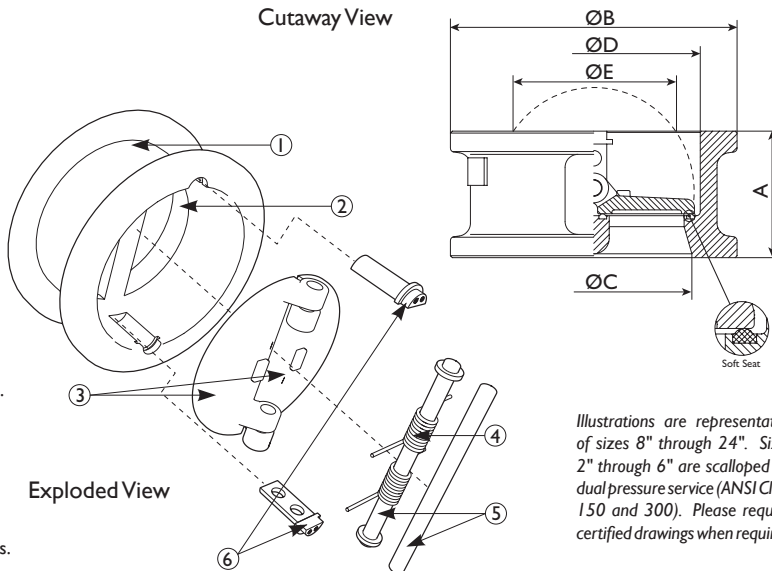

Illustrations are representative of sizes 8" through 24". Sizes 2" through 6" are scalloped for dual pressure service (ANSI Class 150 and 300). Please request certified drawings when required.

DIMENSIONS AND PERFORMANCE DATA ⁽¹⁾

SIZE	in	2	2 1/2	3	4	5	6	8	10	12	14	16	18	20	24
	mm	50	65	80	100	125	150	200	250	300	350	400	450	500	600
A DIMENSION FACE TO FACE ⁽²⁾	in	2.38	2.62	2.88	2.88	3.38	3.88	5.00	5.75	7.12	8.75	9.12	10.38	11.50	12.50
	mm	60	67	73	73	86	98	127	146	181	222	232	264	292	318
ØB DIMENSION OVERALL DIAMETER	in	4.06	4.81	5.31	6.81	7.69	8.69	12.00	14.13	16.56	19.00	21.13	23.38	25.69	30.38
	mm	103	122	135	173	195	221	305	359	420	483	537	594	652	772
ØC DIMENSION INLET DIAMETER	in	2.00	2.56	3.13	4.00	5.00	6.00	8.00	10.00	12.00	13.25	15.25	17.25	19.50	23.44
	mm	51	65	80	102	127	152	203	254	305	337	387	438	495	595
ØD DIMENSION OUTLET DIAMETER	in	2.19	2.69	3.25	4.25	5.12	6.50	8.69	10.63	12.63	13.75	15.75	17.25	19.50	23.44
	mm	56	68	83	108	130	165	220	270	321	350	400	438	495	595
ØE DIMENSION MINIMUM BORE DIAMETER ⁽⁴⁾	in	0.75	1.69	2.38	3.56	4.44	5.31	7.13	8.75	10.44	11.81	14.19	15.81	17.81	21.63
	mm	19	43	60	90	113	135	180	223	265	300	360	402	452	550
ASSEMBLED WEIGHT	lb	5.5	8.0	10.0	15.5	23.5	36.0	66.0	102.0	156.0	236.0	302.0	390.0	540.0	670.0
	kg	2.5	3.6	4.5	7.0	10.6	16.3	29.9	46.3	70.8	107.0	137.0	176.9	244.9	303.9
Flow Coefficient	C _v	62	110	175	350	550	850	1500	2400	3700	5400	8250	10400	14200	23000
Cracking Pressure ⁽³⁾	psi	≤ .25	≤ .25	≤ .25	≤ .25	≤ .25	≤ .25	≤ .25	≤ .25	≤ .25	≤ .25	≤ .25	≤ .25	≤ .25	≤ .25

1. Dimensions and weights are for reference only. When required, request certified drawings.
2. Face to face values have a tolerance of ±0.06 in (±2.0 mm) for sizes 10" and lower and a tolerance of ±0.12 in (±3.0 mm) for sizes 12" and larger.
3. Cracking pressure is for horizontal installations only. For vertical installations, please consult factory.
4. Minimum Bore Diameter indicates the minimum internal diameter of the adjacent pipe.

PRESSURE - TEMPERATURE RATINGS ⁽¹⁾

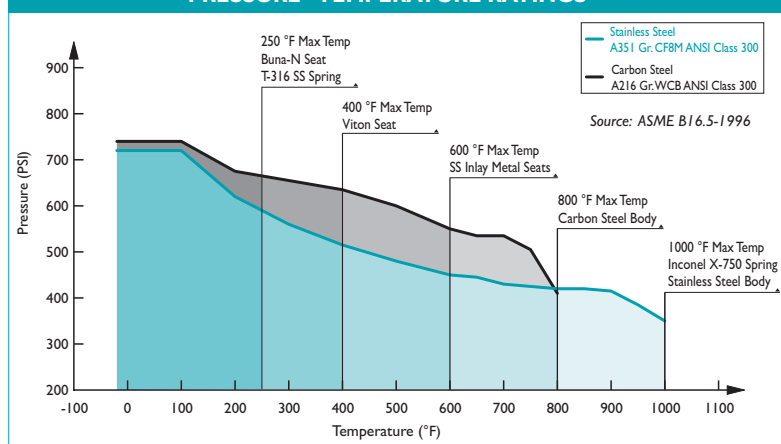

- The above chart displays the pressure-temperature ratings for the valve's body material per ASME B16.5-1996. Max temperature limits have been added for seat and spring materials. For ANSI Class 150 ratings (2" ~ 6"), please refer to the CV 42-CS/SS specification sheet.

Titan FCI makes every effort to ensure the information presented on our literature accurately reflects exact product specifications. However, as product changes occur, there may be short-term differences between actual product specifications and the information contained within our literature. Titan FCI reserves the right to make design and specification changes to improve our products without prior notification. When required, request certified drawings.

REFERENCED STANDARDS & CODES

CODE	DESCRIPTION
ANSI/API 594	Valve Design and Manufacture
ANSI/ASME 16.5	Flange Dimensions
ANSI/API 594	Valve Face to Face Dimensions
API 598	Valve Inspection and Pressure Test

PRESSURE - TEMPERATURE RATING

ANSI CLASS 300	A216 Gr. WCB	A351 Gr. CF8M
WOG (Non-shock):	740 PSI @ 100 °F	720 PSI @ 100 °F

Sizes 2" through 6" are designed for dual pressure service (Class 150 and 300). For ANSI Class 150 ratings, please refer to the CV 42-CC/SS specification sheet.

SEAT AND SPRING TEMPERATURE RATING

Seat Material	Range	Spring Material	Max
VITON:	-40 ~ 400 °F	INCONEL X-750:	1000 °F
BUNA-N:	-20 ~ 250 °F		



TITAN FLOW CONTROL, INC.

CHECK VALVE ♦ WAFER TYPE ♦ DUAL DISC

ANSI CLASS 600 ♦ CARBON AND STAINLESS STEEL

MODEL: CV 46-CS
(CARBON STEEL)

CV 46-SS
(STAINLESS STEEL)

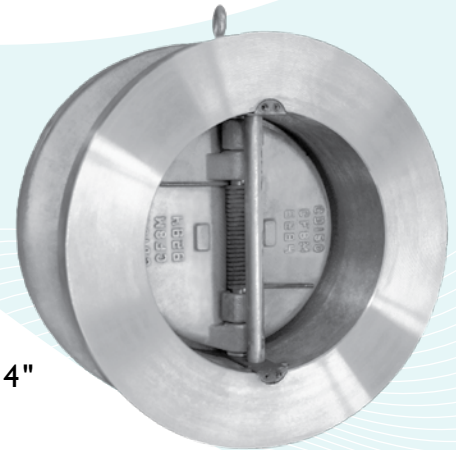

FEATURES

SIZE RANGE: 2" ~ 24"

LARGER SIZES AVAILABLE

- ♦ **COST EFFICIENT DESIGN**
LOW WEIGHT AND SHORT LAYING LENGTH PRODUCE SAVINGS IN INITIAL COST, SPACE REQUIREMENTS, AND INSTALLATION WHEN COMPARED TO FULL-BODY, SWING-TYPE CHECK VALVES.
- ♦ **MINIMAL HEAD LOSS**
CONTOUR OF BODY PROVIDES A SHORT AND STRAIGHT FLOW PATH THAT GENERATES VERY LITTLE TURBULENCE. ADDITIONALLY, THE SPRING-LOADED DISCS ARE DESIGNED WITH VERY LOW CRACKING PRESSURE WHICH REDUCES THE AMOUNT OF ENERGY REQUIRED TO OPEN THE VALVE.
- ♦ **QUICK CLOSURE TO REDUCE WATER HAMMER**
SHUT-OFF IS ACHIEVED VIA THE FULLY AUTOMATIC, SPRING-ASSISTED DISCS THAT CLOSE NEAR ZERO FLOW VELOCITY. THE LIGHTWEIGHT, SPLIT DISC DESIGN CREATES A POSITIVE SHUTOFF PRIOR TO FLOW REVERSAL AND HELPS TO KEEP SLAMMING AND SURGES TO A MINIMUM.
- ♦ **DESIGNED FOR LONG SERVICE LIFE**
THE SPRING AND DISCS ARE DESIGNED TO ALLOW THE DISCS TO LIFT LINEARLY BEFORE PIVOTING TO AVOID THE DISC HEAL FROM SCRUBBING THE SEALING SURFACE. ALSO, DISCS ARE EQUIPPED WITH CAST-IN SHOCK BUMPERS THAT HELP TO REDUCE WEAR AND TEAR ON INTERNAL COMPONENTS.
- ♦ **FUGITIVE EMISSION DESIGN**
THE RETAINER-LESS BODY DESIGN ELIMINATES POTENTIAL LEAK PATHS TO THE ENVIRONMENT SO THERE ARE NO BODY EMISSIONS.
- ♦ **RESILIENT AND METAL SEATS**
BOARD, LAPPED SEALING SURFACE (METAL) MEETS OR EXCEEDS API 598 TEST REQUIREMENTS. OPTIONAL RESILIENT SEATS (VITON/BUNA) ENSURE A BUBBLE TIGHT SEAL.

TECHNICAL

PRESSURE/TEMPERATURE RATING⁽¹⁾
CS - ASTM A216 GR. WCB - CLASS 600

WOG (Non-shock): 1480 PSI @ 100 °F

PRESSURE/TEMPERATURE RATING
SS - ASTM A351 GR. CF8M - CLASS 600

WOG (Non-shock): 1440 PSI @ 100 °F

SEAT MATERIAL TEMPERATURE RANGE

METAL: -325 ~ 1500 °F

VITON: -40 ~ 400 °F

BUNA-N: -20 ~ 250 °F

SPRING MATERIAL TEMPERATURE MAXIMUM

INCONEL X-750: 1000 °F

1. The above listed temperatures are theoretical and may vary during actual operating conditions.

APPLICATIONS

MARKETS: WATER & WASTEWATER, PULP & PAPER, CHEMICAL & PETROCHEMICAL, POWER, PETROLEUM AND OIL & GAS

BUNA-N PROPERTIES: MOST WIDELY USED ELASTOMER. GOOD FOR MOST PETROLEUM OILS AND FLUIDS, SILICONE GREASES AND OILS, AND COLD WATER. EXCELLENT COMPRESSION SET, TEAR, AND ABRASION RESISTANCE. POOR WEATHER RESISTANCE AND MODERATE HEAT RESISTANCE. NOT RECOMMENDED FOR SEVERE OZONE-RESISTANT APPLICATIONS.

VITON PROPERTIES: OFFERS A BROAD RANGE OF CHEMICAL RESISTANCE AND EXCELLENT HEAT RESISTANCE. GOOD MECHANICAL PROPERTIES AND COMPRESSION SET RESISTANCE. OFTEN USED IN APPLICATIONS WHERE NOTHING ELSE WILL WORK. FAIR LOW TEMPERATURE RESISTANCE AND LIMITED HOT-WATER RESISTANCE AND SHRINKAGE.

The above data represents common market and service applications. No representation or guarantee, expressed or implied, is given due to the numerous variations of concentrations, temperatures and flow conditions that may occur during actual service.

TITAN FLOW CONTROL, INC.

YOUR PIPELINE TO THE FUTURE!

Tel: 910-735-0000 ♦ Fax: 910-738-3848 ♦ titan@titanfci.com ♦ www.titanfci.com
290 Corporate Drive ♦ PO Box 7408 ♦ Lumberton, NC 28358



TITAN FLOW CONTROL, Inc.
 290 Corporate Drive
 Lumberton, NC 28358
 Tel: 910.735.0000
 E-mail: titan@titanfci.com
 Web: www.titanfci.com
 Fax: 910.738.3848

CHECK VALVE • WAFER TYPE • DUAL DISC
MODEL: CV 46-CS (Carbon Steel)
CV 46-SS (Stainless Steel)

ANSI Class
 600

BILL OF MATERIALS ⁽¹⁾

No.	PART	CV 46-CS	CV 46-SS
1	Body	Carbon Steel ⁽⁴⁾ A216 Gr. WCB	Stainless Steel A351 Gr. CF8M
2	Seat	Metal ⁽⁵⁾ , Buna-N	Metal, Viton
3	Disc ⁽²⁾	Stainless Steel A351 Gr. CF8M	Stainless Steel A351 Gr. CF8M
4	Spring ⁽²⁾	Inconel X-750	Inconel X-750
5	Shaft/Stop Pin	Stainless Steel A276 Gr. 316	Stainless Steel A276 Gr. 316
6	Pin Cap ⁽³⁾	Stainless Steel A276 Gr. 316	Stainless Steel A276 Gr. 316

Illustrations are representative of sizes 6" through 24". Please ask for certified drawings when required.

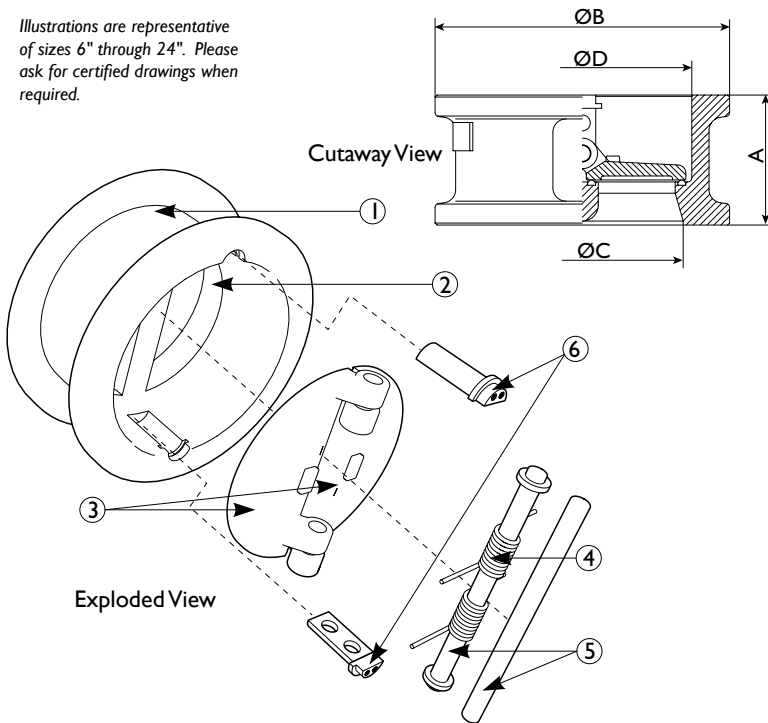

- Equivalent or better materials may be substituted at the manufacturer's discretion.
- Denotes recommended spare parts.
- Pin Cap is only on sizes 6" through 24".
- Carbon Steel bodies are epoxy painted.
- Metal seat has stainless steel inlay.

REFERENCED STANDARDS & CODES

CODE	DESCRIPTION
ANSI/API 594	Check Valve Design and Manufacture
API 598	Valve Inspection and Testing
API 6D	Pipeline Valves

DIMENSIONS AND PERFORMANCE DATA ⁽¹⁾

SIZE	in	2	2 1/2	3	4	5	6	8	10	12	14	16	18	20	24
	mm	50	65	80	100	125	150	200	250	300	350	400	450	500	600
A DIMENSION ⁽²⁾ FACE TO FACE	in	2.375	2.625	2.875	3.125	4.125	5.375	6.50	8.375	9.00	10.75	12.00	14.25	14.50	17.25
	mm	60	67	73	79	105	136	165	213	229	273	305	362	368	438
ØB DIMENSION OVERALL DIAMETER	in	4.312	5.062	5.812	7.50	9.437	10.375	12.50	15.687	17.937	19.312	22.125	24.00	26.75	30.937
	mm	110	128	147	191	240	264	318	398	455	490	562	610	680	786
ØC DIMENSION INLET DIAMETER	in	2.00	2.562	3.00	4.00	5.00	6.00	7.875	9.843	11.812	13.187	15.156	17.125	19.187	23.031
	mm	51	65	76	102	127	152	200	250	300	335	385	435	487	585
ØD DIMENSION OUTLET DIAMETER	in	2.187	2.687	3.25	4.25	5.125	6.50	8.25	10.062	11.812	13.187	15.156	17.125	19.187	23.031
	mm	55	68	82	108	130	165	210	255	300	335	385	435	487	585
ASSEMBLED WEIGHT	lb	6	13	12	20	35	57	109	207	300	420	627	820	1015	1690
	kg	3	6	5	9	16	26	49	94	136	191	284	372	460	767
Flow Coefficient	C _v	45	95	140	200	400	580	1350	1850	2500	4800	5520	7500	10300	11100
Cracking Pressure ⁽³⁾	psi	≤ .25	≤ .25	≤ .25	≤ .25	≤ .25	≤ .25	≤ .25	≤ .25	≤ .25	≤ .25	≤ .25	≤ .25	≤ .25	≤ .25

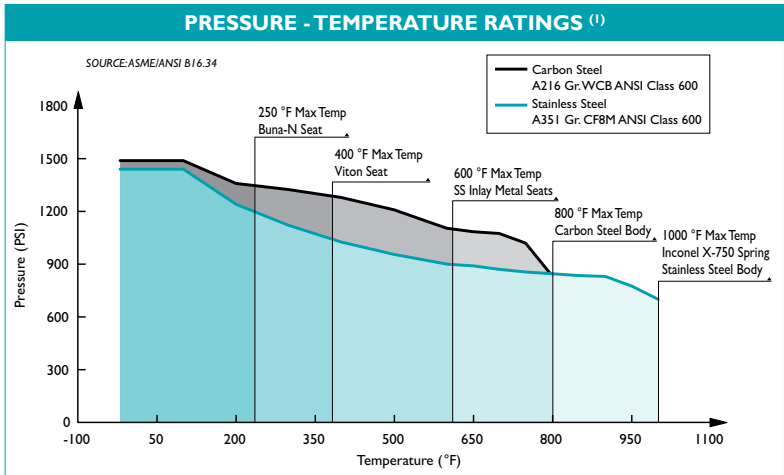

I. The above chart displays the pressure-temperature ratings for the valve's body material per ASME B16.34-1996. Max temperature limits have been added for seat and spring materials.

- Dimensions and weights are for reference only. When required, request certified drawings.
- Face to face values have a tolerance of ±0.06 in (±2.0 mm) for sizes 10" and lower and a tolerance of ±0.12 in (±3.0 mm) for sizes 12" and larger.
- Cracking pressure is for horizontal installations only. For vertical installations, please consult factory.

PRESSURE - TEMPERATURE RATING

ANSI CLASS 600	A216 Gr. WCB	A351 Gr. CF8M
WOG (Non-shock):	1480 PSI @ 100 °F	1440 PSI @ 100 °F

SEAT AND SPRING TEMPERATURE RATING

Seat Material	Range	Spring Material	Max
VITON:	-40 ~ 400 °F	INCONEL X-750:	1000 °F
BUNA-N:	-20 ~ 250 °F		
METAL:	-325 ~ 1500 °F		

Additional Design & Technical Notes:

- The CV 46 has a fugitive emission design. This retainer-less body design eliminates potential leak paths to the environment so there are no body emissions.



TITAN FLOW CONTROL, INC.

CHECK VALVE ♦ WAFER TYPE ♦ DUAL DISC

ANSI CLASS 900 ♦ CARBON AND STAINLESS STEEL

MODEL: CV 47-CS
(CARBON STEEL)

CV 47-SS
(STAINLESS STEEL)

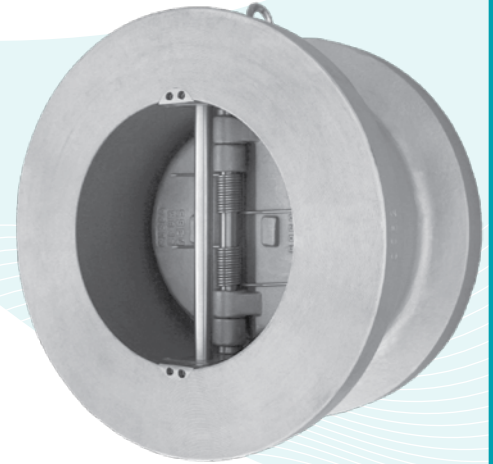

FEATURES

SIZE RANGE: 2" ~ 24"
LARGER SIZES AVAILABLE

- ♦ **COST EFFICIENT DESIGN**
LOW WEIGHT AND SHORT LAYING LENGTH PRODUCE SAVINGS IN INITIAL COST, SPACE REQUIREMENTS, AND INSTALLATION WHEN COMPARED TO FULL-BODY, SWING-TYPE CHECK VALVES.
- ♦ **MINIMAL HEAD LOSS**
CONTOUR OF BODY PROVIDES A SHORT AND STRAIGHT FLOW PATH THAT GENERATES VERY LITTLE TURBULENCE. ADDITIONALLY, THE SPRING-LOADED DISCS ARE DESIGNED WITH VERY LOW CRACKING PRESSURE WHICH REDUCES THE AMOUNT OF ENERGY REQUIRED TO OPEN THE VALVE.
- ♦ **QUICK CLOSURE TO REDUCE WATER HAMMER**
SHUT-OFF IS ACHIEVED VIA THE FULLY AUTOMATIC, SPRING-ASSISTED DISCS THAT CLOSE NEAR ZERO FLOW VELOCITY. THE LIGHTWEIGHT, SPLIT DISC DESIGN CREATES A POSITIVE SHUTOFF PRIOR TO FLOW REVERSAL AND HELPS TO KEEP SLAMMING AND SURGES TO A MINIMUM.
- ♦ **DESIGNED FOR LONG SERVICE LIFE**
THE SPRING AND DISCS ARE DESIGNED TO ALLOW THE DISCS TO LIFT LINEARLY BEFORE PIVOTING TO AVOID THE DISC HEAL FROM SCRUBBING THE SEALING SURFACE. ALSO, DISCS ARE EQUIPPED WITH CAST-IN SHOCK BUMPERS THAT HELP TO REDUCE WEAR AND TEAR ON INTERNAL COMPONENTS.
- ♦ **FUGITIVE EMISSION DESIGN**
THE RETAINER-LESS BODY DESIGN ELIMINATES POTENTIAL LEAK PATHS TO THE ENVIRONMENT SO THERE ARE NO BODY EMISSIONS.
- ♦ **RESILIENT AND METAL SEATS**
BOARD, LAPPED SEALING SURFACE (METAL) MEETS OR EXCEEDS API 598 TEST REQUIREMENTS. OPTIONAL RESILIENT SEATS (VITON/BUNA) ENSURE A BUBBLE TIGHT SEAL.

TECHNICAL

PRESSURE/TEMPERATURE RATING ⁽¹⁾
CS - ASTM A216 GR. WCB - CLASS 900

WOG (Non-shock): 2220 PSI @ 100 °F

PRESSURE/TEMPERATURE RATING
SS - ASTM A351 GR. CF8M - CLASS 900

WOG (Non-shock): 2160 PSI @ 100 °F

SEAT MATERIAL
TEMPERATURE RANGE

METAL: -325 ~ 1500 °F
VITON: -40 ~ 400 °F
BUNA-N: -20 ~ 250 °F

SPRING MATERIAL
TEMPERATURE MAXIMUM

INCONEL X-750: 1000 °F

1. The above listed temperatures are theoretical and may vary during actual operating conditions.

APPLICATIONS

MARKETS: WATER & WASTEWATER, PULP & PAPER, CHEMICAL & PETROCHEMICAL, POWER, PETROLEUM AND OIL & GAS

BUNA-N PROPERTIES: MOST WIDELY USED ELASTOMER. GOOD FOR MOST PETROLEUM OILS AND FLUIDS, SILICONE GREASES AND OILS, AND COLD WATER. EXCELLENT COMPRESSION SET, TEAR, AND ABRASION RESISTANCE. POOR WEATHER RESISTANCE AND MODERATE HEAT RESISTANCE. NOT RECOMMENDED FOR SEVERE OZONE-RESISTANT APPLICATIONS.

VITON PROPERTIES: OFFERS A BROAD RANGE OF CHEMICAL RESISTANCE AND EXCELLENT HEAT RESISTANCE. GOOD MECHANICAL PROPERTIES AND COMPRESSION SET RESISTANCE. OFTEN USED IN APPLICATIONS WHERE NOTHING ELSE WILL WORK. FAIR LOW TEMPERATURE RESISTANCE AND LIMITED HOT-WATER RESISTANCE AND SHRINKAGE.

The above data represents common market and service applications. No representation or guarantee, expressed or implied, is given due to the numerous variations of concentrations, temperatures and flow conditions that may occur during actual service.

TITAN FLOW CONTROL, INC.
YOUR PIPELINE TO THE FUTURE!

Tel: 910-735-0000 ♦ Fax: 910-738-3848 ♦ titan@titanfci.com ♦ www.titanfci.com
290 Corporate Drive ♦ PO Box 7408 ♦ Lumberton, NC 28358



TITAN FLOW CONTROL, Inc.
 290 Corporate Drive
 Lumberton, NC 28358
 Tel: 910.735.0000
 E-mail: titan@titanfci.com
 Web: www.titanfci.com
 Fax: 910.738.3848

CHECK VALVE • WAFER TYPE • DUAL DISC
MODEL: CV 47-CS (Carbon Steel)
CV 47-SS (Stainless Steel)

ANSI Class
 900

BILL OF MATERIALS (1)

No.	PART	CV 47-CS	CV 47-SS
1	Body	Carbon Steel (4) A216 Gr.WCB	Stainless Steel A351 Gr. CF8M
2	Seat	Metal (5), Buna-N	Metal, Viton
3	Disc (2)	Stainless Steel A351 Gr. CF8M	Stainless Steel A351 Gr. CF8M
4	Spring (2)	Inconel X-750	Inconel X-750
5	Shaft/Stop Pin	Stainless Steel A276 Gr. 316	Stainless Steel A276 Gr. 316
6	Pin Cap (3)	Stainless Steel A276 Gr. 316	Stainless Steel A276 Gr. 316

1. Equivalent or better materials may be substituted at the manufacturer's discretion.
2. Denotes recommended spare parts.
3. Pin Cap is only on sizes 6" through 24".
4. Carbon Steel bodies are epoxy painted.
5. Metal seat has stainless steel inlay.

Illustrations are representative of sizes 6" through 24". Please ask for certified drawings when required.

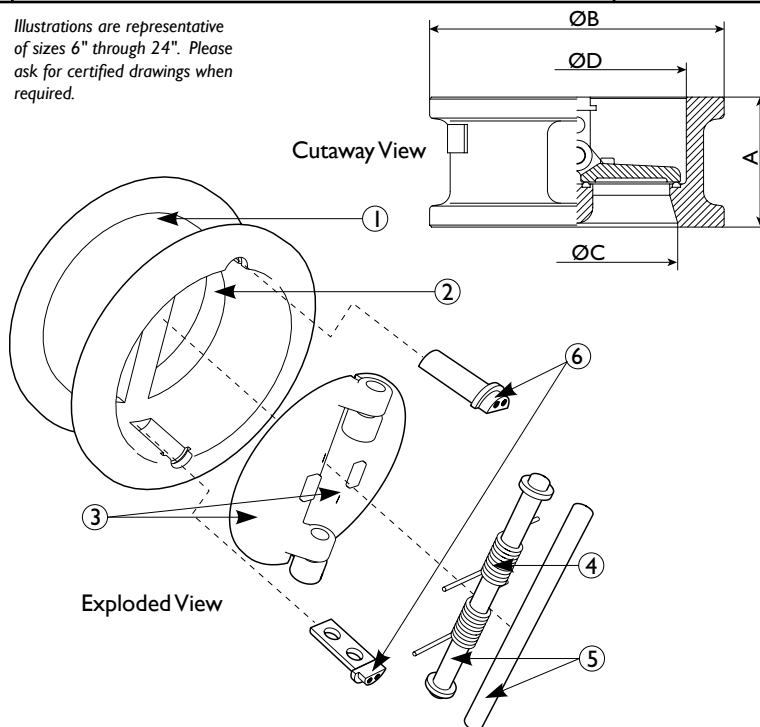

REFERENCED STANDARDS & CODES

CODE	DESCRIPTION
ANSI/API 594	Check Valve Design and Manufacture
API 598	Valve Inspection and Testing
API 6D	Pipeline Valves

DIMENSIONS AND PERFORMANCE DATA (1)

SIZE	in	2	2 1/2	3	4	5	6	8	10	12	14	16	18	20	24
	mm	50	65	80	100	125	150	200	250	300	350	400	450	500	600
A DIMENSION (2) FACE TO FACE	in	2.75	3.25	3.25	4.00	C/F	6.25	8.125	9.50	11.50	14.00	15.125	17.75	17.75	19.50
	mm	70	83	83	102	C/F	159	206	241	292	356	384	451	451	495
ØB DIMENSION OVERALL DIAMETER	in	5.50	6.50	6.625	8.062	C/F	11.25	14.00	17.00	19.50	20.50	22.50	25.062	27.375	32.875
	mm	140	165	168	205	C/F	286	356	432	495	520	572	636	696	835
ØC DIMENSION INLET DIAMETER	in	2.00	C/F	3.00	3.875	C/F	5.875	7.875	9.375	11.812	12.812	14.937	16.75	18.70	22.437
	mm	50	C/F	76	98	C/F	150	200	238	300	325	380	425	475	570
ØD DIMENSION OUTLET DIAMETER	in	2.187	C/F	3.25	4.25	C/F	6.312	8.25	10.062	11.812	12.812	14.937	16.75	18.687	22.437
	mm	55	C/F	82	108	C/F	160	210	255	300	325	380	425	475	570
ASSEMBLED WEIGHT	lb	13	19	22	38	66	178	300	465	655	875	1170	1322	1390	2650
	kg	6	9	10	17	30	81	136	211	297	397	531	600	630	1202
Flow Coefficient	C _v	40	80	120	190	380	500	1000	1500	1900	2900	4500	7000	9000	10800
Cracking Pressure (3)	psi	≤ .25	≤ .25	≤ .25	≤ .25	≤ .25	≤ .25	≤ .25	≤ .25	≤ .25	≤ .25	≤ .25	≤ .25	≤ .25	≤ .25

PRESSURE - TEMPERATURE RATINGS (1)

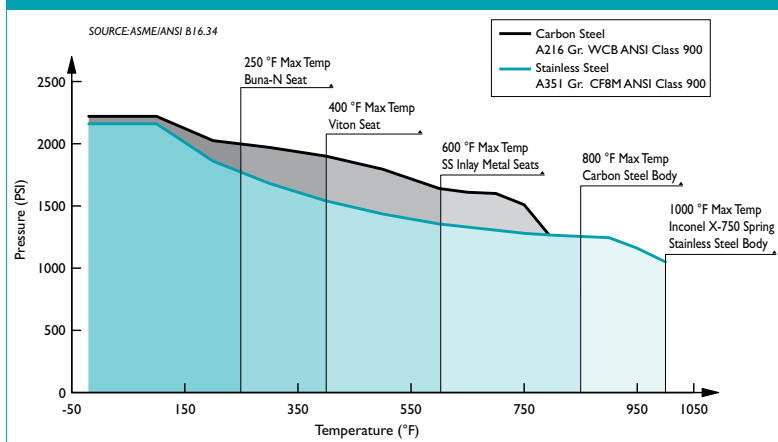

1. The above chart displays the pressure-temperature ratings for the valve's body material per ASME B16.34-1996. Max temperature limits have been added for seat and spring materials.

1. Dimensions and weights are for reference only. When required, request certified drawings.
2. Face to face values have a tolerance of ±0.06 in (±2.0 mm) for sizes 10" and lower and a tolerance of ±0.12 in (±3.0 mm) for sizes 12" and larger.
3. Cracking pressure is for horizontal installations only. For vertical installations, please consult factory.

PRESSURE - TEMPERATURE RATING

ANSI CLASS 900	A216 Gr.WCB	A351 Gr. CF8M
WOG (Non-shock):	2220 PSI @ 100 °F	2160 PSI @ 100 °F

SEAT AND SPRING TEMPERATURE RATING

Seat Material	Range	Spring Material	Max
VITON:	-40 ~ 400 °F	INCONEL X-750:	1000 °F
BUNA-N:	-20 ~ 250 °F		
METAL:	-325 ~ 1500 °F		

Additional Design & Technical Notes:

- The CV 47 has a fugitive emission design. This retainer-less body design eliminates potential leak paths to the environment so there are no body emissions.



SWING CHECK VALVE ♦ WAFER TYPE ♦ SHORT PATTERN

ANSI CLASS 150 ♦ CARBON STEEL & STAINLESS STEEL

MODELS: CV 12-CS

Body: Carbon Steel
Seat/Seal: Buna-N

CV 12-SS

Body: Stainless Steel
Seat/Seal: PTFE

SIZES: 2" ~ 24"



FEATURES

- ♦ **ROBUST DESIGN**
THIS IS A SELF-ACTING, NON-RETURN, SINGLE PLATE, WAFER TYPE SWING CHECK VALVE WHICH PROVIDES HIGH QUALITY AND RELIABILITY WITHIN A SIMPLIFIED CONSTRUCTION. AVAILABLE IN BOTH CARBON STEEL AND STAINLESS STEEL.
- ♦ **MINIMAL HEAD LOSS**
THE LOW INERTIA DISC IS DESIGNED TO OPEN AND CLOSE UNDER LOW DIFFERENTIAL PRESSURE CONDITIONS. ALSO, THE SHORT PATTERN DESIGN AND STRAIGHT FLOW PATH MINIMIZE PRESSURE DROP ACROSS THE VALVE.
- ♦ **ECONOMICAL DESIGN**
THE LOW WEIGHT AND SHORT FACE-TO-FACE DIMENSIONS PROVIDE AN ECONOMICAL, SPACE-SAVING SOLUTION. ADDITIONALLY, FLANGE GASKETS ARE TYPICALLY NOT REQUIRED DUE TO THE BUILT-IN, BODY SEAL O-RINGS.
- ♦ **RESILIENT SOFT SEATS**
SOFT SEATS (PTFE OR BUNA) COMBINED WITH A GRAVITY ASSISTED DISC HELP TO ENSURE A POSITIVE SHUTOFF WHICH CREATES A BUBBLE TIGHT SEAL THAT MEETS OR EXCEEDS API 598 LEAKAGE REQUIREMENTS.
- ♦ **VERSATILE DESIGN**
THIS VALVE CAN BE INSTALLED BETWEEN WELD NECK OR SLIP-ON TYPE COMPANION FLANGES OF DIFFERENT STANDARDS. THIS VALVE CAN NOT BE INSTALLED IN A VERTICAL PIPELINE WITH DOWNWARD FLOW.
- ♦ **FUGITIVE EMISSION DESIGN**
THE ONE-PIECE BODY DESIGN ELIMINATES POTENTIAL LEAK PATHS TO THE ENVIRONMENT SO THERE ARE NO BODY EMISSIONS.

TECHNICAL

PRESSURE/TEMPERATURE RATING ⁽¹⁾
CS - ASTM A515 GR. 70 - CLASS 150

WOG (Non-shock): 285 PSI @ 100 °F

PRESSURE/TEMPERATURE RATING ⁽¹⁾
SS - ASTM A240 GR. 316 - CLASS 150

WOG (Non-shock): 275 PSI @ 100 °F

SEAT AND BODY SEAL (O-RING) ⁽¹⁾
TEMPERATURE RANGE

PTFE: 14 ~ 320 °F
BUNA-N: -20 ~ 250 °F

1. The above listed temperatures are theoretical and may vary during actual operating conditions.

APPLICATIONS

MARKETS: OIL AND GAS PRODUCTION, GENERAL INDUSTRY, CHEMICAL, & PETROCHEMICAL

SERVICE: THIS VALVE IS INTENDED FOR LOW FLOW SERVICE THAT IS STEADY, CLEAN (NO ABRASIVES OR SOLIDS), AND NON-PULSATING. FLOW RATE MUST NOT EXCEED FOR LIQUIDS: 15 FT/SEC

PTFE PROPERTIES: GOOD FOR MOST CHEMICAL ENVIRONMENTS. OFFERS EXCELLENT TEAR, ABRASIVE, CHEMICAL, ACID, AND ALKALI RESISTANCE. NOT RECOMMENDED FOR HIGH PRESSURE STEAM OR LARGE TEMPERATURE VARIATIONS.

BUNA-N PROPERTIES: MOST WIDELY USED ELASTOMER. GOOD FOR MOST PETROLEUM OILS AND FLUIDS, SILICONE GREASES AND OILS, AND COLD WATER. EXCELLENT COMPRESSION SET, TEAR, AND ABRASION RESISTANCE. POOR WEATHER RESISTANCE AND MODERATE HEAT RESISTANCE. NOT RECOMMENDED FOR SEVERE OZONE-RESISTANT APPLICATIONS.

The above data represents common market and service applications. No representation or guarantee, expressed or implied, is given due to the numerous variations of concentrations, temperatures and flow conditions that may occur during actual service.

TITAN FLOW CONTROL, INC.
YOUR PIPELINE TO THE FUTURE!

Tel: 910-735-0000 ♦ Fax: 910-738-3848 ♦ titan@titanfci.com ♦ www.titanfci.com
290 Corporate Drive ♦ PO Box 7408 ♦ Lumberton, NC 28358



TITAN FLOW CONTROL, Inc.
 290 Corporate Drive
 Lumberton, NC 28358
 Tel: 910.735.0000
 E-mail: titan@titanfci.com
 Web: www.titanfci.com
 Fax: 910.738.3848

SWING CHECK VALVE • WAFER TYPE
SINGLE DISC • SHORT PATTERN DESIGN
MODELS: CV 12-CS (Carbon Steel)
CV 12-SS (Stainless Steel)

ANSI
 Class 150

BILL OF MATERIALS (1)

No.	PART	CV 12-CS	CV 12-SS
1	Body	Carbon Steel A515 Gr. 70	Stainless Steel A240 Gr. 316
2	Disc	Carbon Zinc Plated	Stainless Steel A351 Gr. CF8M
3	Seat (2)	Buna-N	PTFE
4	Body Seal (2)	Buna-N	PTFE
5	Bolt	Stainless Steel Type 304-SS	Stainless Steel Type 304-SS
6	Eye Bolt	Chrome Plated	Chrome Plated

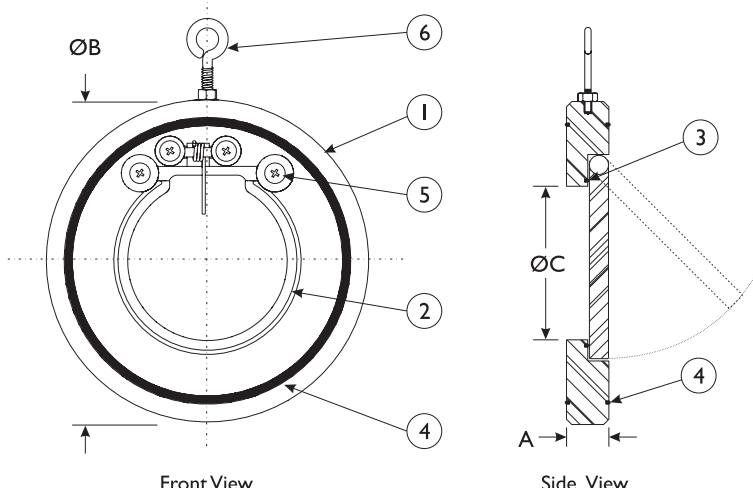

1. Bill of Materials represents standard materials. Equivalent or better materials may be substituted at the manufacturer's discretion.
2. Denotes recommended spare parts.

DIMENSIONS AND PERFORMANCE DATA (1)

SIZE	in	2	2 1/2	3	4	5	6	8	10	12	14	16	18	20	24
	mm	50	65	80	100	125	150	200	250	300	350	400	450	500	600
A DIMENSION FACE TO FACE (2)	in	0.55	0.55	0.55	0.71	0.71	0.79	0.87	1.02	1.26	1.50	1.73	1.97	2.21	2.44
	mm	14	14	14	18	18	20	22	26	32	38	44	50	56	62
ØB DIMENSION OVERALL DIAMETER	in	4.13	4.90	5.40	6.90	7.76	8.74	11.00	13.39	16.14	17.76	20.28	21.70	23.90	28.25
	mm	105	124	137	175	197	222	280	340	410	451	515	550	606	718
ØC DIMENSION INLET DIAMETER	in	1.26	1.58	2.13	2.76	3.62	4.41	6.06	7.87	9.45	10.60	12.13	14.17	15.95	19.14
	mm	32	40	54	70	92	112	154	200	240	269	308	360	405	486
ASSEMBLED WEIGHT	lb	2.5	3.5	6.0	7.0	8.5	10.0	22.0	33.5	58.0	93.5	146.5	195.0	232.0	352.0
	kg	1.1	1.6	2.7	3.2	3.9	4.5	10.0	15.2	26.3	42.4	66.5	88.5	105.1	159.5
Flow Coefficient	C _v	62	100	166	318	470	610	1250	2300	4150	4980	8225	11906	20000	27700
Cracking Pressure (3)	psi	≤ .25	≤ .25	≤ .25	≤ .25	≤ .25	≤ .25	≤ .25	≤ .25	≤ .25	≤ .25	≤ .25	≤ .25	≤ .25	≤ .25

1. Dimensions, weights, and flow coefficients are provided for reference only. When required, always request certified drawings.
2. Face to face values have a tolerance of ±0.06 in (±2.0 mm) for sizes 10" and smaller and a tolerance of ±0.12 in (±3.0 mm) for sizes 12" and larger.
3. Cracking pressure is for horizontal installations only. For vertical installations, please consult factory. Valve can not be installed in the vertical position with downward flow.

PRESSURE-TEMPERATURE RATINGS (1)

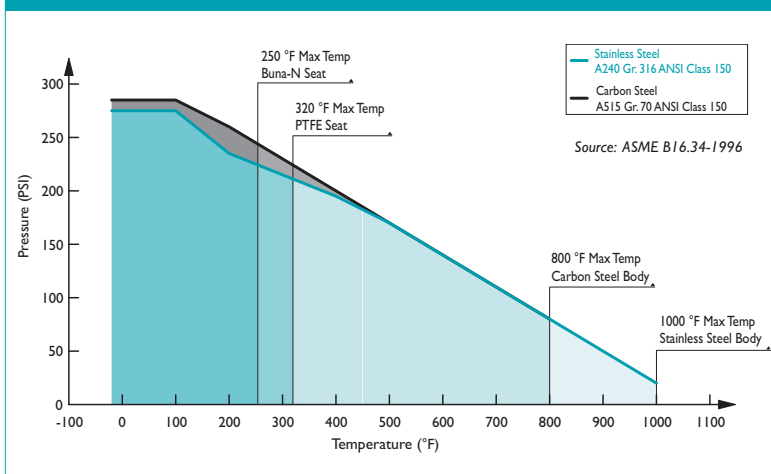

1. This chart displays the pressure-temperature ratings for the valve's body. Max temperature limits have been added for seat, body seal, and spring materials.

REFERENCED STANDARDS & CODES

CODE	DESCRIPTION
API 598 / ANSI B16.5	Valve Testing
ASME/ANSI B16.34	Valves - Flanged, Threaded, & Welding End
ANSI 150	Flange Standard Conformity

PRESSURE/TEMPERATURE RATING

ANSI CLASS 150	A240 Gr. 316	A515 Gr. 70
WOG (Non-shock)	275 PSI @ 100 °F	285 PSI @ 100 °F

SEAT/BODY SEAL TEMPERATURE RANGE (1)

SEAT	Temperature
PTFE	14 ~ 320 °F
Buna-N	-20 ~ 250 °F

1. The listed pressure and temperature ratings for the valve's body, seat, and body seal are theoretical and may vary during actual operating conditions.

ORDERING CODE

Model Number	Description
CV 12-CS	Carbon Steel Body, Buna-N Seat
CV 12-SS	Stainless Steel Body, PTFE Seat

Additional Design & Technical Notes:

Short pattern check valves feature a reduced port and eccentric opening which allow the disc to open into the connecting pipe. However, given the short face-to-face, the disc will not fully open due to interference with the connecting pipe. Although this conforms to API specifications, this may be unsuitable for certain types applications. Consult factory for more specific application information.

Titan FCI makes every effort to ensure the information presented on our literature accurately reflects exact product specifications. However, as product changes occur, there may be short-term differences between actual product specifications and the information contained within our literature. Titan FCI reserves the right to make design and specification changes to improve our products without prior notification. When required, request certified drawings.



TITAN FLOW CONTROL, INC.

SWING CHECK VALVE ♦ WAFER TYPE ♦ SINGLE DISC

ANSI CLASS 125/150 ♦ DUCTILE IRON

MODEL: CV 31-DI

Body: Ductile Iron
 Seat: Buna-N
 Disc: Stainless Steel

NEWLY
 DESIGNED...
 Face to face meets
 API 594.



FEATURES

- ♦ **ECONOMICAL DESIGN**
 LOW WEIGHT AND SHORT LAYING LENGTH PRODUCE SAVINGS IN INITIAL COST, SPACE REQUIREMENTS, AND INSTALLATION WHEN COMPARED TO FULL-BODY, SWING-TYPE CHECK VALVES.
- ♦ **MINIMAL HEAD LOSS**
 HEAD LOSS IS MINIMIZED BY PROVIDING A SHORT, STRAIGHT AND VIRTUALLY UNOBSTRUCTED FLOW PATH. ADDITIONALLY, THE SPRING-LOADED DISC IS DESIGNED WITH VERY LOW CRACKING PRESSURE WHICH REDUCES THE AMOUNT OF ENERGY REQUIRED TO OPEN THE VALVE.
- ♦ **QUICK CLOSURE TO REDUCE WATER HAMMER**
 SHUT-OFF IS ACHIEVED VIA THE FULLY AUTOMATIC, SPRING-ASSISTED DISC THAT CLOSES NEAR ZERO FLOW VELOCITY. THE LIGHTWEIGHT, SINGLE DISC DESIGN CREATES A POSITIVE SHUTOFF PRIOR TO FLOW REVERSAL WHICH HELPS TO KEEP SURGES TO A MINIMUM.
- ♦ **DURABLE, HIGH QUALITY DESIGN**
 THE CV31'S DUCTILE IRON BODY MAINTAINS THE ANTI-CORROSIVE PROPERTIES OF CAST IRON WHILE ACHIEVING A YIELD STRENGTH COMPARABLE TO CARBON STEEL. DUCTILE IRON ALSO OFFERS HIGHER PRESSURE/TEMPERATURE RATINGS THAN CAST IRON IN THE SAME PRESSURE CLASS. THE CV31 ALSO FEATURES ANTI-CORROSIVE, STAINLESS STEEL TRIM (DISC, SPRING, SHAFT) AS STANDARD.
- ♦ **RESILIENT SOFT SEATS**
 FIELD REPLACEABLE, RESILIENT SOFT SEATS (BUNA-N O-RING) COUPLED WITH PRECISION MACHINED SEALING SURFACES HELP TO ENSURE A BUBBLE TIGHT SEAL THAT MEETS OR EXCEEDS API 598 TEST REQUIREMENTS.

SIZES: 2" ~ 12"

TECHNICAL

PRESSURE/TEMPERATURE RATING
 DI - ASTM A536 - CLASS 150 ⁽¹⁾

WOG (Non-shock): 250 PSI @ 100 °F

SEAT MATERIAL
 TEMPERATURE RANGE

BUNA-N: -20 ~ 250 °F

SPRING MATERIAL
 MAXIMUM TEMPERATURE

Series 300 Stainless Steel: 450 °F

1. Ductile Iron valves offer higher pressure ratings than Cast Iron valves. For example, Ductile Iron valves (2" ~ 24") are rated at 250 psi wog. By comparison, Cast Iron valves (2" ~ 12") are rated at 200 psi wog and (14" ~ 24") are only rated at 150 psi wog.

APPLICATIONS

MARKETS: GENERAL INDUSTRY, CHEMICAL, PETROCHEMICAL, POWER, AND FOOD & BEVERAGE

SERVICE: INTENDED FOR LIQUID SERVICE THAT IS STEADY, CLEAN (NO ABRASIVES OR SOLIDS) AND NON-PULSATING. FLOW RATE SHOULD NOT EXCEED 15 FT/SEC. NOT RECOMMENDED FOR STEAM OR RECIPROCATING COMPRESSOR SERVICE.

BUNA-N PROPERTIES: MOST WIDELY USED ELASTOMER. GOOD FOR MOST PETROLEUM OILS AND FLUIDS, SILICONE GREASES AND OILS, AND COLD WATER. EXCELLENT COMPRESSION SET, TEAR, AND ABRASION RESISTANCE. POOR WEATHER RESISTANCE AND MODERATE HEAT RESISTANCE. NOT RECOMMENDED FOR SEVERE OZONE-RESISTANT APPLICATIONS.

The above data represents common market and service applications. No representation or guarantee, expressed or implied, is given due to the numerous variations of concentrations, temperatures and flow conditions that may occur during actual service.

TITAN FLOW CONTROL, INC.
YOUR PIPELINE TO THE FUTURE!

Tel: 910-735-0000 ♦ Fax: 910-738-3848 ♦ titan@titanfci.com ♦ www.titanfci.com
 290 Corporate Drive ♦ PO Box 7408 ♦ Lumberton, NC 28358



TITAN FLOW CONTROL, Inc.

290 Corporate Drive
Lumberton, NC 28358
Tel: 910.735.0000
Fax: 910.738.3848

E-mail: titan@titanfci.com
Web: www.titanfci.com

SWING CHECK VALVE • WAFER TYPE • SINGLE DISC

MODEL: CV 31-DI (Ductile Iron Body)

Buna-N Seat • Stainless Steel Disc

ANSI
Class
125/150

BILL OF MATERIALS ⁽¹⁾

No.	PART	CV 31-DI
1	Body	Ductile Iron ASTM A536
2	Seat	Buna-N O-Ring
3	Disc ⁽²⁾	Stainless Steel AISI 316
4	Plug	Carbon Steel ASTM A307B
5	Spring ⁽²⁾	Series 300 Stainless Steel
6	Spacer	PTFE Commercial
7	Shaft	Stainless Steel AISI 316
8	Eye Bolt	Carbon Steel ASTM A307B

1. Bill of Materials represents standard materials. Equivalent or better materials may be substituted at the manufacturer's discretion. All materials conform to ASTM specifications.
2. Denotes recommended spare parts.

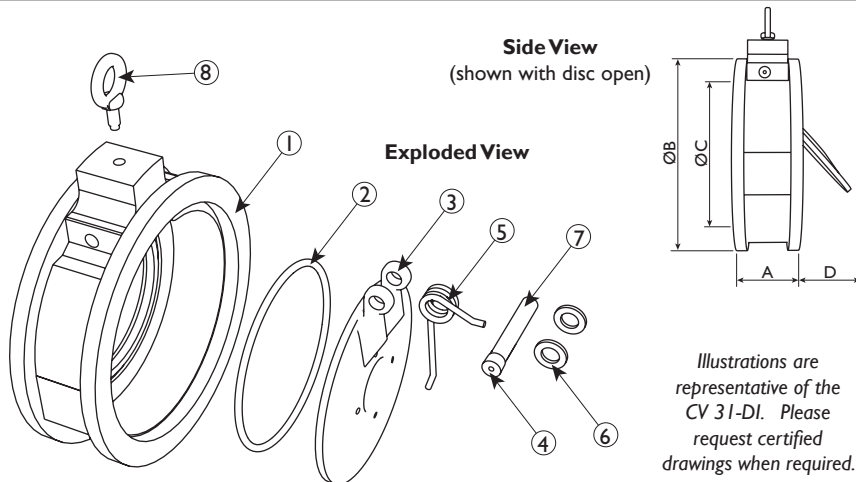

Illustrations are representative of the CV 31-DI. Please request certified drawings when required.

DIMENSIONS AND PERFORMANCE DATA ⁽¹⁾

SIZE	in	2	2 1/2	3	4	5	6	8	10	12
	mm	50	65	80	100	125	150	200	250	300
A DIMENSION FACE TO FACE ⁽²⁾	in	2.12 ⁽⁴⁾	2.38 ⁽⁴⁾	2.62 ⁽⁴⁾	2.62 ⁽⁴⁾	3.25 ⁽⁴⁾	3.75 ⁽⁴⁾	5.0 ⁽⁴⁾	5.5 ⁽⁴⁾	7.12 ⁽⁴⁾
	mm	54	61	67	67	83	95	127	140	181
ØB DIMENSION OVERALL DIAMETER	in	4.00	4.88	5.25	6.88	7.75	8.75	11.00	13.38	16.13
	mm	102	124	133	175	197	223	280	340	410
ØC DIMENSION INLET DIAMETER	in	1.31	1.85	2.06	3.00	3.75	4.75	6.44	7.63	9.50
	mm	34	47	53	77	96	121	164	194	242
D DIMENSION DISC MAX TRAVEL	in	0.75	1.00	0.80	1.87	3.30	2.70	3.00	4.62	4.00
	mm	19	25.5	20.3	47.5	83.8	68.6	76	117	102
ASSEMBLED WEIGHT	lb	4.0	5.0	7.0	11.0	16.0	16.0	32.0	44.0	60.0
	kg	1.8	2.3	3.2	5.0	7.2	7.3	14.5	20.0	27.2
Flow Coefficient	C _v	62	109	166	318	471	720	1384	2298	4153
Cracking Pressure ⁽³⁾	psi	≤ .25	≤ .25	≤ .25	≤ .25	≤ .25	≤ .25	≤ .25	≤ .25	≤ .25

1. Dimensions, weights, and flow coefficients are for reference only. When required, request certified drawings.
2. Face to face values have a tolerance of ±0.06 in (±2.0 mm) for sizes 10" and lower and a tolerance of ±0.12 in (±3.0 mm) for sizes 12" and larger.
3. Cracking pressure is for horizontal installations only. For vertical installations, please consult factory.
4. Face to face dimensions per API 594 Class 125.

PRESSURE-TEMPERATURE RATINGS

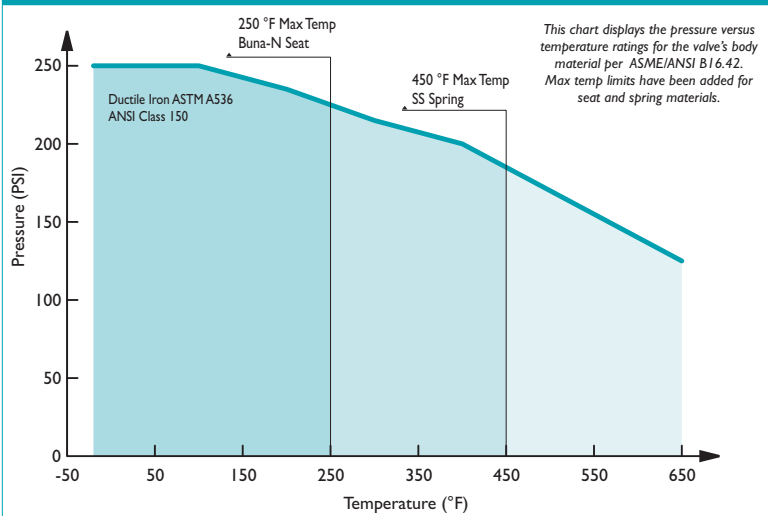

Ductile Iron Application Notes: Ductile Iron maintains the anti-corrosive properties of Cast Iron while achieving a yield strength comparable to Carbon Steel. Ductile Iron also offers higher pressure/temperature ratings than Cast Iron. For example, Ductile Iron check valves (class 150 - sizes 2" ~ 24") are rated at 250 psi wog. By comparison, Cast Iron check valves (class 125 - sizes 2" ~ 12") are rated at 200 psi wog and (sizes 14" ~ 24") are only rated at 150 psi wog. Ductile Iron ANSI Classes 150 has the same bolting pattern as Cast Iron ANSI Class 125.

REFERENCED STANDARDS & CODES

CODE	DESCRIPTION
ANSI B16.42	Ductile Iron Pipe Flanges and Flanged Fittings
ANSI B16.5	Pipe Flanges & Flanged Fittings
API 594	Wafer, Wafer-Lug, & Double Flanged Type Check Valve
API 598	Valve Inspection and Testing
MSS SP-6	Standard Finishes for Connecting-end Flanges
MSS SP-25	Standard Marking System for Valves
MSS SP-55	Quality Standard for Valve Castings

PRESSURE/TEMPERATURE RATING ⁽¹⁾

Pressure Class	Ductile Iron A536 Class 150
WOG (Non-shock)	250 PSI @ 100 °F

SEAT AND SPRING TEMPERATURE RATINGS ⁽¹⁾

SEAT (O-Ring)	Temperature Range
Buna-N	-20 °F @ 250 °F
SPRING	Maximum Temperature
Series 300 Stainless Steel	450 °F

1. The listed pressure and temperature ratings for the valve's body, seat, and spring are theoretical and may vary during actual operating conditions.

Titan FCI makes every effort to ensure the information presented on our literature accurately reflects exact product specifications. However, as product changes occur, there may be short-term differences between actual product specifications and the information contained within our literature. Titan FCI reserves the right to make design and specification changes to improve our products without prior notification. When required, request certified drawings.



TITAN FLOW CONTROL, INC.

SWING CHECK VALVE ♦ WAFER TYPE ♦ SINGLE DISC

ANSI CLASS 150 ♦ CARBON AND STAINLESS STEEL

MODELS: CV 32-CS

(Carbon - Viton)

CV 32-SS

(Stainless - PTFE)



SIZES: 2" ~ 12"

FEATURES

- ♦ **ECONOMICAL DESIGN**
LOW WEIGHT AND SHORT LAYING LENGTH PRODUCE SAVINGS IN INITIAL COST, SPACE REQUIREMENTS, AND INSTALLATION WHEN COMPARED TO FULL-BODY, SWING-TYPE CHECK VALVES.
- ♦ **MINIMAL HEAD LOSS**
HEAD LOSS IS MINIMIZED BY PROVIDING A SHORT, STRAIGHT AND VIRTUALLY UNOBSTRUCTED FLOW PATH. ADDITIONALLY, THE SPRING-LOADED DISC IS DESIGNED WITH VERY LOW CRACKING PRESSURE WHICH REDUCES THE AMOUNT OF ENERGY REQUIRED TO OPEN THE VALVE.
- ♦ **QUICK CLOSURE TO REDUCE WATER HAMMER**
SHUT-OFF IS ACHIEVED VIA THE FULLY AUTOMATIC, SPRING-ASSISTED DISC THAT CLOSES NEAR ZERO FLOW VELOCITY. THE LIGHTWEIGHT, SINGLE DISC DESIGN CREATES A POSITIVE SHUTOFF PRIOR TO FLOW REVERSAL WHICH HELPS TO KEEP SURGES TO A MINIMUM.
- ♦ **DURABLE, HIGH QUALITY DESIGN**
THE CV32 CHECK VALVE IS AVAILABLE IN EITHER CARBON STEEL OR STAINLESS STEEL BODY CONFIGURATIONS, WHICH ALLOW IT TO PERFORM WELL IN HIGHER TEMPERATURE APPLICATIONS. THE CARBON STEEL UNITS ARE EPOXY PAINTED. ADDITIONALLY, BOTH MODELS FEATURE ANTI-CORROSIVE, STAINLESS STEEL TRIM (DISC, SPRING, SHAFT) AS STANDARD.
- ♦ **RESILIENT SOFT SEATS**
RESILIENT SOFT SEATS (VITON AND PTFE O-RING) COUPLED WITH PRECISION MACHINED SEALING SURFACES HELP TO ENSURE A BUBBLE TIGHT SEAL THAT MEETS OR EXCEEDS API 598 TEST REQUIREMENTS.

TECHNICAL

PRESSURE/TEMPERATURE RATING
CS - ASTM A216 Gr. WCB - CLASS 150

WOG (Non-shock): 285 PSI @ 100 °F

PRESSURE/TEMPERATURE RATING
SS - ASTM A351 Gr. CF8M - CLASS 150

WOG (Non-shock): 275 PSI @ 100 °F

SEAT MATERIAL (O-RING)
TEMPERATURE RANGE

VITON: -40 ~ 400 °F
PTFE: 14 ~ 248 °F

SPRING MATERIAL
MAXIMUM TEMPERATURE

Series 300 Stainless Steel: 450 °F

APPLICATIONS

MARKETS: GENERAL INDUSTRY, CHEMICAL, PETROCHEMICAL, POWER, AND FOOD & BEVERAGE

SERVICE: INTENDED FOR LIQUID SERVICE THAT IS STEADY, CLEAN (NO ABRASIVES OR SOLIDS) AND NON-PULSATING. FLOW RATE SHOULD NOT EXCEED 15 FT/SEC. NOT RECOMMENDED FOR STEAM OR RECIPROCATING COMPRESSOR SERVICE.

PTFE PROPERTIES: RECOMMENDED FOR MOST CHEMICAL ENVIRONMENTS INCLUDING ACIDS, BASES, OILS, STEAM AND OTHER PROCESS FLUIDS. OFFERS EXCELLENT TEAR, ABRASIVE, CHEMICAL, ACID, AND ALKALI RESISTANCE. NOT RECOMMENDED FOR HIGH PRESSURE STEAM OR LARGE TEMPERATURE VARIATION APPLICATIONS.

VITON PROPERTIES: OFFERS A BROAD RANGE OF CHEMICAL RESISTANCE AND EXCELLENT HEAT RESISTANCE. GOOD MECHANICAL PROPERTIES AND COMPRESSION SET RESISTANCE. OFTEN USED IN APPLICATIONS WHERE NOTHING ELSE WILL WORK. FAIR LOW TEMPERATURE RESISTANCE AND LIMITED HOT-WATER RESISTANCE AND SHRINKAGE.

The above data represents common market and service applications. No representation or guarantee, expressed or implied, is given due to the numerous variations of concentrations, temperatures and flow conditions that may occur during actual service.

TITAN FLOW CONTROL, INC.
YOUR PIPELINE TO THE FUTURE!

Tel: 910-735-0000 ♦ Fax: 910-738-3848 ♦ titan@titanfci.com ♦ www.titanfci.com
290 Corporate Drive ♦ PO Box 7408 ♦ Lumberton, NC 28358



TITAN FLOW CONTROL, Inc.

290 Corporate Drive
Lumberton, NC 28358
Tel: 910.735.0000
Fax: 910.738.3848

E-mail: titan@titanfci.com
Web: www.titanfci.com

**SWING CHECK VALVE • WAFER TYPE
SINGLE DISC**

**MODELS: CV 32-CS (Carbon - Viton Seat)
CV 32-SS (Stainless - PTFE Seat)**

ANSI
Class 150

BILL OF MATERIALS ⁽¹⁾

Illustrations are representative of the CV 32-CS/SS.
Please request certified drawings when required.

No.	PART	CV 32-CS	CV 32-SS
1	Body	Carbon Steel A216 Gr.WCB	Stainless Steel A351 Gr. CF8M
2	Seat ⁽²⁾	Viton O-Ring	PTFE Commercial O-Ring
3	Disc ⁽²⁾	Stainless Steel AISI 316	Stainless Steel AISI 316
4	Plug	Carbon Steel ASTM A307B	Stainless Steel AISI 316
5	Spring ⁽²⁾	Series 300 Stainless Steel	Series 300 Stainless Steel
6	Spacer	PTFE Commercial	PTFE Commercial
7	Shaft	Stainless Steel AISI 316	Stainless Steel AISI 316
8	Eye Bolt	Carbon Steel ASTM A307B	Carbon Steel ASTM A307B

1. Bill of Materials represents standard materials. Equivalent or better materials may be substituted at the manufacturer's discretion. All materials conform to ASTM specifications.
2. Denotes recommended spare parts.

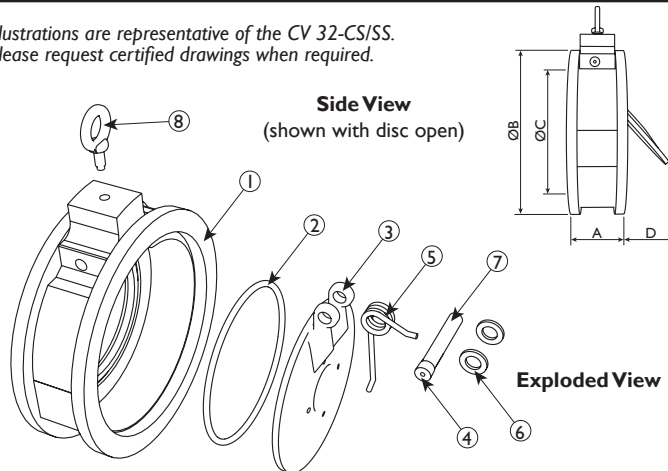

DIMENSIONS AND PERFORMANCE DATA ⁽¹⁾

SIZE	in	2	2 1/2	3	4	5	6	8	10	12
	mm	50	65	80	100	125	150	200	250	300
A DIMENSION FACE TO FACE ⁽²⁾	in	2.38	2.62	2.62	2.62	3.25	3.75	5	5.75	7.12
	mm	60	67	67	67	83	95	127	146.05	180.85
ØB DIMENSION OVERALL DIAMETER	in	4.00	4.875	5.25	6.75	7.75	8.625	10.875	13.25	16.0
	mm	102	124	133	171	197	219	276	337	406
ØC DIMENSION INLET DIAMETER	in	1.313	1.85	2.063	3.00	3.75	4.75	6.438	7.625	9.50
	mm	34	47	53	77	96	121	164	194	242
D DIMENSION DISC MAX TRAVEL	in	0.5	0.62	0.8	1.87	3.3	2.7	3	4.35	4
	mm	12	15.5	20.3	47.5	83.8	68.6	76	110.5	102
ASSEMBLED WEIGHT	lb	5.0	6.0	8.0	12.0	18.0	22.0	30.0	48.0	140.0
	kg	2.3	2.7	3.6	5.4	8.2	10.0	13.6	21.8	64.0
Flow Coefficient	C _v	62	109	166	318	471	720	1384	2298	4153
Cracking Pressure ⁽³⁾	psi	≤ .25	≤ .25	≤ .25	≤ .25	≤ .25	≤ .25	≤ .25	≤ .25	≤ .25

1. Dimensions, weights, and flow coefficients are for reference only. When required, request certified drawings.
2. Face to face values have a tolerance of ±0.06 in (±2.0 mm) for sizes 10" and lower and a tolerance of ±0.12 in (±3.0 mm) for sizes 12" and larger.
3. Cracking pressure is for horizontal installations only. For vertical installations, please consult factory.

PRESSURE-TEMPERATURE RATINGS ⁽¹⁾

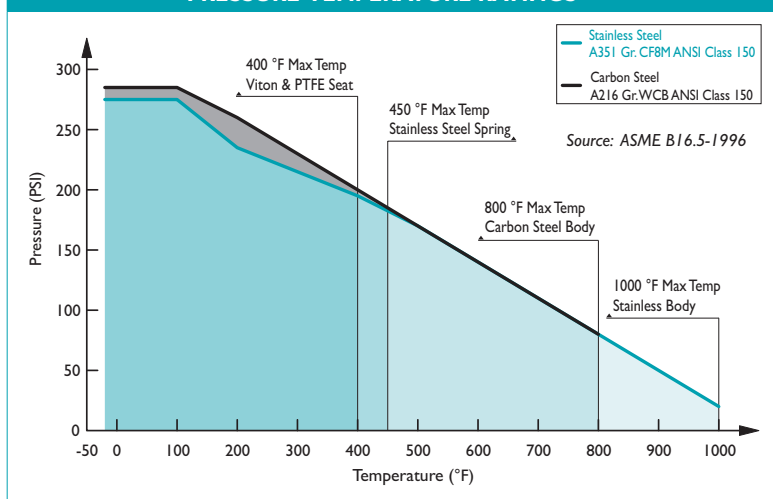

1. The above chart displays the pressure-temperature ratings for the valve's body material per ASME B16.5. Max temperature limits have been added for seat and spring materials.

PRESSURE/TEMPERATURE RATING ⁽¹⁾

Class 150	Carbon Steel A216 Gr.WCB	Stainless Steel A351 Gr. CF8M
WOG (Non-shock)	285 PSI @ 100 °F	275 PSI @ 100 °F

REFERENCED STANDARDS & CODES

CODE	DESCRIPTION
ANSI B16.34	Steel Valves - Flanged, Threaded, & Welding Ends
ANSI B16.10	Face-to-Face & End-to-End Dimensions of Valves
ANSI B16.5	Pipe Flanges & Flanged Fittings
API 598	Valve Inspection and Testing
MSS SP-6	Standard Finishes for Connecting-end Flanges
MSS SP-25	Standard Marking System for Valves
MSS SP-55	Quality Standard for Valve Castings

SEAT AND SPRING TEMPERATURE RATINGS ⁽¹⁾

SEAT (O-Ring)	Temperature Range
Viton	-40 ~ 400 °F
PTFE	14 ~ 248 °F
SPRING ⁽²⁾	Maximum Temperature
Series 300 Stainless Steel	450 °F

1. The listed pressure and temperature ratings for the valve's body, seat, and spring are theoretical and may vary during actual operating conditions.
2. As the temperature increases, the load capacity of the spring diminishes significantly. At higher temperatures, a different material spring may be required. Please consult for specific application assistance.



TITAN FLOW CONTROL, INC.

FULL BODY SWING CHECK VALVE ♦ FLANGED ENDS ♦ SINGLE DISC

ANSI CLASS 125 ♦ CAST IRON BODY

MODELS: CV 31F-CI

Body: Cast Iron
Body Seat: Bronze
Disc: Cast Iron
Disc Seat: Buna-N

CV 31WF-CI

Body: Cast Iron
Body Seat: Bronze
Disc: Cast Iron
Disc Seat: Buna-N
Weight & Lever: Cast Iron



SIZES: 2" ~ 12"

FEATURES

◆ PROVEN DESIGN

THE FULL BODY SWING CHECK IS ONE OF THE MOST WELL-KNOWN TYPES OF CHECK VALVES. A PROVEN DESIGN, IT IS IDEAL FOR PREVENTING FLOW REVERSAL WHICH AIDS IN PROTECTING PUMPS, COMPRESSORS, AND DOWNSTREAM TANKS AND VESSELS. THE TITAN CV31F CAN ALSO BE USED TO ISOLATE HIGH PRESSURE SYSTEMS FROM LOW PRESSURE SYSTEMS AND TO PREVENT CONTAMINATION BETWEEN SYSTEMS.

◆ LESSEN WATER HAMMER

THE TITAN CV31F CAN BE EQUIPPED WITH ADJUSTABLE WEIGHTS AND LEVERS TO PREVENT THE DISC FROM OPENING UNTIL A DESIRED PRESSURE IS REACHED. THE WEIGHTS AND LEVERS PROVIDE QUICKER CLOSING AND AID IN THE REDUCTION OF SLAMMING BY KEEPING THE DISC WITHIN THE FLUID FLOW. THE WEIGHTS AND LEVERS PROVIDE THE ADDITIONAL BENEFIT OF VISUALLY DISPLAYING THE POSITION OF THE DISC.

◆ HEAD LOSS

THE TITAN CV31F HAS A PATH THAT IS VIRTUALLY UNOBSTRUCTED AND AIDS IN REDUCING HEAD LOSS.

◆ RESILIENT SOFT SEAT

THE SOFT SEAT (BUNA-N) DISC SEAT COUPLED WITH PRECISION MACHINED SEALING SURFACES HELPS TO ENSURE A DROP-TIGHT SEAL THAT MEETS AWWA C508. THE BUNA-N SEAT PROVIDES EXCELLENT COMPRESSION SET, TEAR, AND ABRASION RESISTANCE. IT IS APPLICABLE FOR MOST WATER, WASTEWATER, AND PETROLEUM APPLICATIONS.

◆ DURABLE CONSTRUCTION

THE CV31F IS A ONE-PIECE, CAST IRON BODY DESIGN WITH A BOLTED COVER. SPECIAL COATINGS CONFORMING TO AWWA C508 ARE AVAILABLE.

TECHNICAL

PRESSURE/TEMPERATURE RATING

WOG (Non-shock): 200 PSI @ 125 °F

HYDROSTATIC SHELL TEST

2 × WOG for 60 seconds = 400 PSI

SEAT TEST

1 × WOG for 15 seconds applied on downstream side of disc.

1. The above listed temperatures are theoretical and may vary during actual operating conditions.
2. Duration of test is defined by AWWA C508 spec.



The CV 31WF-CI comes equipped with a weight and lever.

APPLICATIONS

MARKETS: WATER & WASTEWATER, PULP & PAPER, CHEMICAL & PETROCHEMICAL, PETROLEUM, OIL & GAS.

The above data represents common market and service applications. No representation or guarantee, expressed or implied, is given due to the numerous variations of concentrations, temperatures and flow conditions that may occur during actual service.

TITAN FLOW CONTROL, INC.

YOUR PIPELINE TO THE FUTURE!

Tel: 910-735-0000 ♦ Fax: 910-738-3848 ♦ titan@titanfci.com ♦ www.titanfci.com
290 Corporate Drive ♦ PO Box 7408 ♦ Lumberton, NC 28358



TITAN FLOW CONTROL, Inc.
 290 Corporate Drive
 Lumberton, NC 28358
 Tel: 910.735.0000
 Fax: 910.738.3848

E-mail: titan@titanfci.com
 Web: www.titanfci.com

FULL BODY SWING CHECK VALVE • FLANGED ENDS • SINGLE DISC

**MODEL: CV 31F-CI (Cast Iron Body)
 CV 31WF-CI (Cast Iron Body)**

Bronze Seat • Cast Iron/Buna-N Disc

**ANSI
 Class
 125**

BILL OF MATERIALS (1)

No.	PART	CV 31F-CI
1	Body	Cast Iron ASTM A126 Gr.B
2	Body Seat	Bronze ASTM B62 C83600
3	Disc	Cast Iron ASTM A126 Gr.B
4	Side Plug	Brass ASTM B16 C36000
5	Cover	Cast Iron ASTM A126 Gr.B
6	Hanger Pin	Stainless Steel AISI 420
7	Hanger	Ductile Iron ASTM A536 65-45-12
8	Gasket	Non-asbestos
9	Disc Seat	Buna-N

1. Bill of Materials represents standard materials. Equivalent or better materials may be substituted at the manufacturer's discretion. All materials conform to ASTM specifications.

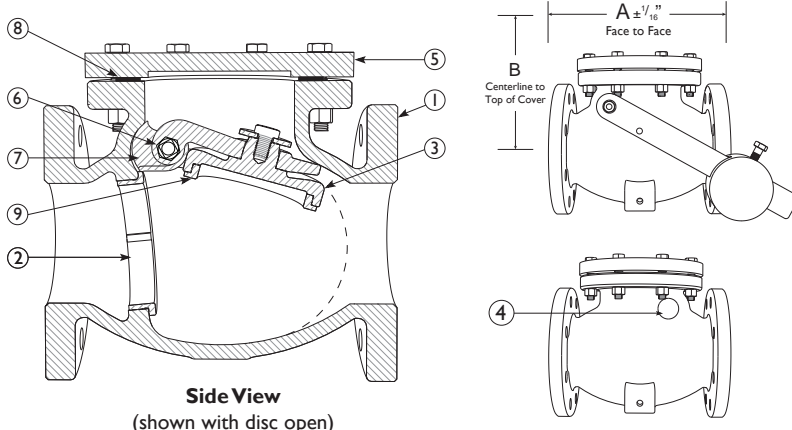

Side View
(shown with disc open)

DIMENSIONS AND PERFORMANCE DATA (1)

SIZE	in	2	2 1/2	3	4	5	6	8	10	12
	mm	50	65	80	100	125	150	200	250	300
A DIMENSION FACE TO FACE (2)(3)	in	8.00	8.50	9.50	11.50	13.00	14.00	19.50	24.50	27.52
	mm	203	216	241	292	330	356	495	622	699
ØB DIMENSION CENTER LINE TO TOP	in	5.00	5.40	5.79	6.54	7.50	8.55	10.45	11.81	13.47
	mm	127	137	147	166	191	217	265	300	342
ASSEMBLED WEIGHT WITHOUT WEIGHT AND LEVER	lb	25.35	36.38	46.30	55.12	92.60	110.0	230.0	370.38	537.93
	kg	11.50	16.50	21.00	25.00	42.00	50.00	104.00	168.00	244.00
ASSEMBLED WEIGHT WITH WEIGHT AND LEVER	lb	38.50	49.60	58.20	92.60	134.92	170.64	287.0	453.0	660.30
	kg	17.50	22.50	26.40	42.00	61.20	77.40	130.20	205.50	299.50
Flow Coefficient WITHOUT WEIGHT AND LEVER	C _v	48	76	109	198	310	446	801	1260	1821

1. Dimensions, weights, and flow coefficients are for reference only. When required, request certified drawings.
2. Face to face values have a tolerance of ±0.06 in (±2.0 mm) for sizes 10" and lower and a tolerance of ±0.12 in (±3.0 mm) for sizes 12" and larger.
3. Face to face values meet AWWA C508 spec for "full waterway" valves.

PRESSURE DROP CHART (1)

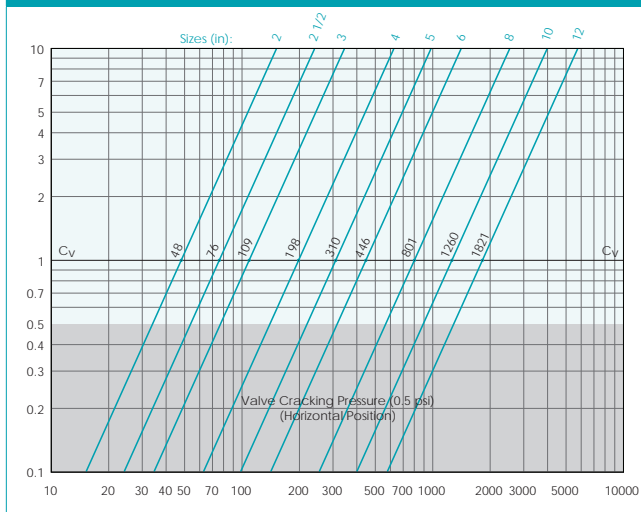

1. This chart displays Cv values for the CV 31-F. Consult factory for information on the CV 31WF-CI.

REFERENCED STANDARDS & CODES

CODE	DESCRIPTION
ANSI B16.1	Cast Iron Pipe Flanges and Flanged Fittings Class 125.
ANSI B16.10	Face to Face & End to End Dimensions of Valves.
MSS SP-71	Gray Iron Swing Check Valves, Flanged and Threaded End.
AWWA C508	Swing Check Valves for Waterworks Service.

PRESSURE - TEMPERATURE RATING

ANSI CLASS 125	A126 Gr. B
WOG (Non-shock):	200 PSI @ 125 °F

1. The listed pressure and temperature ratings for the valve's body and seat are theoretical and may vary during actual operating conditions.

Titan FCI makes every effort to ensure the information presented on our literature accurately reflects exact product specifications. However, as product changes occur, there may be short-term differences between actual product specifications and the information contained within our literature. Titan FCI reserves the right to make design and specification changes to improve our products without prior notification. When required, request certified drawings.



TITAN FLOW CONTROL, INC.

BLOW-OFF DRAIN VALVE ♦ TWO-PIECE BALL VALVE

WOG 600 ♦ BRONZE ♦ MALE x FEMALE THREADED ENDS

MODEL: **BV 60-BZ**
(CAST BRONZE)

SIZE RANGE: 1/4" ~ 2"



FEATURES

- ♦ **FULL PORT FLOW**
FULL PORT DESIGN OFFERS COMPLETE AND RAPID CLEANING OF STRAINER SCREEN WITH MINIMAL PRESSURE DROP.
- ♦ **SIMPLE OPERATION**
QUICK QUARTER TURN OPENS OR CLOSES VALVE. LOCKING HANDLE IS ALSO AVAILABLE.
- ♦ **DIRECT CONNECTION TO STRAINER**
MALE THREADED ENDS MOUNT DIRECTLY INTO STRAINER BLOW-OFF CONNECTION FOR CONVENIENT BLOW DOWN CLEANING.
- ♦ **FACTORY INSTALLATION AS BLOW-OFF VALVE**
BALL VALVE CAN BE PROFESSIONALLY INSTALLED TO A TITAN STRAINER AT OUR FACTORY, ENSURING QUALITY AND REDUCING SHIPPING AND LABOR COSTS.
- ♦ **RUGGED, HIGH QUALITY DESIGN**
THE BV 60 FEATURES A CHROMIUM PLATED BALL, REINFORCED-PTFE SEAT, AND BLOW-OUT PROOF STEM DESIGN.



CAN BE PROFESSIONALLY INSTALLED
AT THE TITAN FACTORY!

TECHNICAL

PRESSURE/ TEMPERATURE RATING
BRONZE ASTM B62

WOG (Non-shock): 600 PSI @ 100 °F
Max Liquid: 80 PSI @ 400 °F
Saturated Steam: 150 PSI @ 366 °F

SEAT MATERIAL
TEMPERATURE RANGE

R-PTFE: -100 °F - 400 °F

1. The above listed temperatures are theoretical and may vary during actual operating conditions.

APPLICATIONS

SCREEN CLEANING: DURING NORMAL USE, THE STRAINER SCREEN WILL BECOME CLOGGED WITH FOREIGN MATTER CAUSING THE DIFFERENTIAL PRESSURE TO INCREASE. ONCE THE DIFFERENTIAL PRESSURE HAS REACHED AN UNACCEPTABLE VALUE, BLOW-DOWN CLEANING IS RECOMMENDED. IT IS NOT ADVISABLE TO ALLOW THE DIFFERENTIAL PRESSURE TO INCREASE BY 20 PSI AS THIS MAY CAUSE THE SCREEN TO FAIL AND POSSIBLY DAMAGE DOWNSTREAM EQUIPMENT. IF THE DIFFERENTIAL PRESSURE IS NOT RESTORED TO NORMAL PARAMETERS AFTER BLOW-DOWN CLEANING THEN THE SCREEN MUST BE REMOVED AND CLEANED OR REPLACED.

The above data represents common market and service applications. No representation or guarantee, expressed or implied, is given due to the numerous variations of concentrations, temperatures and flow conditions that may occur during actual service.

TITAN FLOW CONTROL, INC.

YOUR PIPELINE TO THE FUTURE!

Tel: 910-735-0000 ♦ Fax: 910-738-3848 ♦ titan@titanfci.com ♦ www.titanfci.com
290 Corporate Drive ♦ PO Box 7408 ♦ Lumberton, NC 28358



TITAN FLOW CONTROL, Inc.

290 Corporate Drive
Lumberton, NC 28358
Tel: 910.735.0000

E-mail: titan@titanfci.com
Web: www.titanfci.com
Fax: 910.738.3848

BLOW-OFF DRAIN VALVE • BALL VALVE TYPE

BV 60-BZ (Cast Bronze)

Male x Female Ends • Two-Piece Design

Working Pressure:
600 PSI

BILL OF MATERIALS ⁽¹⁾

No.	PART	BV 60-BZ
1	Body	Bronze, ASTM B62
2	Cap	Bronze, ASTM B62
3	Ball	Brass, Chrome Plated
4	Ball Seat ⁽²⁾	R-PTFE, 15% Glass Filled
5	Joint Gasket ⁽²⁾	PTFE
6	Stem	Brass
7	Thrust Washer ⁽²⁾	PTFE
8	Stem Packing ⁽²⁾	PTFE
9	Gland Nut	Brass
10	Handle	T-304 SS
11	Spring Washer	T-304 SS
12	Stem Nut	T-304 SS
13	Plastic Cover	Plastic

- 1. Equivalent or better materials may be substituted at the manufacturer's discretion.
- 2. Denotes recommended spare parts.

Illustrations are for representational purposes only. Please ask for certified drawings when required.

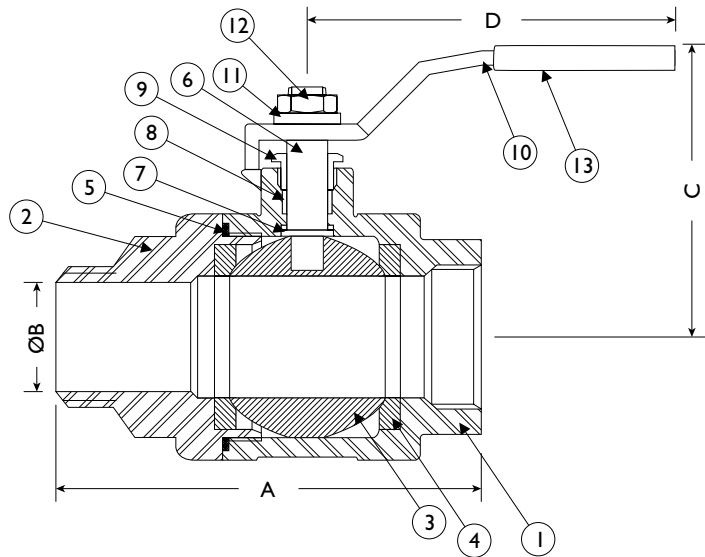

**MALE X FEMALE
THREADED ENDS**



MALE END MOUNTS DIRECTLY IN THE STRAINER'S BLOW OFF CONNECTION

DIMENSIONS AND PERFORMANCE DATA ⁽¹⁾

SIZE	in	1/4	3/8	1/2	3/4	1	1 1/4	1 1/2	2
	mm	8	10	15	20	25	32	40	50
A DIMENSION FACE TO FACE ⁽²⁾	in	1.75	1.75	2.17	2.64	3.15	C/F	4.32	4.78
	mm	44	44	55	67	80	C/F	110	121
ØB DIMENSION INSIDE DIAMETER	in	0.38	0.48	0.63	0.88	1.13	C/F	1.49	2.04
	mm	10	12	16	22	29	C/F	38	52
C DIMENSION HORIZONTAL CENTER LINE TO TOP OF HANDLE	in	1.7	1.7	1.7	2.12	2.25	C/F	2.825	3.25
	mm	43	43	43	54	57	C/F	72	83
D DIMENSION VERTICAL CENTER LINE TO END OF HANDLE	in	3.43	3.43	3.43	4.5	4.5	C/F	5.5	5.5
	mm	87	87	87	114	114	C/F	140	140
APPROXIMATE WEIGHT	lb	< 0.5	< 0.5	0.5	0.5	1	C/F	2.5	3.5
	kg	< 0.23	< 0.23	0.23	0.23	0.45	C/F	1.13	1.59
Flow Coefficient	C _v	18	18	18	42	74	130	210	380

- 1. Dimensions and weights are for reference only. When required, request certified drawings.
- 2. Face to face values have a tolerance of ±0.06 in (±2.0 mm) for sizes 10" and lower and a tolerance of ±0.12 in (±3.0 mm) for sizes 12" and larger.

PRESSURE - TEMPERATURE RATINGS ⁽¹⁾

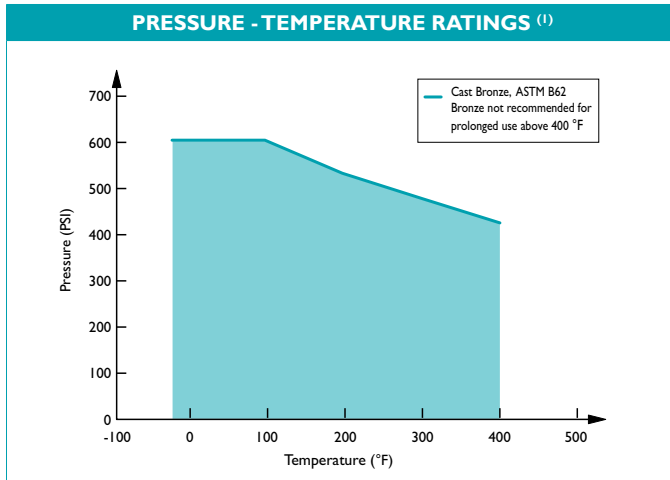

1. This chart displays the pressure versus temperature ratings for the valve's body.

REFERENCED STANDARDS & CODES

CODE	DESCRIPTION
ASME/ANSI B16.15	Cast Bronze Threaded Fittings

PRESSURE - TEMPERATURE RATING

Operating Conditions	Range
WOG (Non-shock):	600 PSI @ 100 °F
Saturated Steam:	150 PSI @ 366 °F
Max Liquid:	80 PSI @ 400 °F

SEAT TEMPERATURE RATING

Seat Material	Range
Reinforced-PTFE	-100 °F - 400 °F

Titan FCI makes every effort to ensure the information presented on our literature accurately reflects exact product specifications. However, as product changes occur, there may be short-term differences between actual product specifications and the information contained within our literature. Titan FCI reserves the right to make design and specification changes to improve our products without prior notification. When required, request certified drawings.



TITAN FLOW CONTROL, INC.

BLOW-OFF DRAIN VALVE ♦ HIGH PRESSURE BALL VALVE

3000 WOG ♦ STAINLESS STEEL ♦ TWO PIECE DESIGN

MODELS:

BV 24 (3000 WOG - Female x Female)

BV 25 (3000 WOG - Male x Female)

1/4" THROUGH 2"



FEATURES

- ♦ FULL PORT DESIGN OFFERS COMPLETE AND RAPID CLEANING OF STRAINER SCREEN; SIZE 2" IS REDUCED PORT
- ♦ IDEAL BLOW-OFF VALVE FOR HIGH PRESSURE STRAINERS ANSI CLASS 600, 900, AND 1500
- ♦ DIRECT MOUNT ACTUATION - MEETS ISO 5211
- ♦ OPTIONAL SAFETY "DEAD-MAN", SPRING RETURN HANDLE IS AVAILABLE
- ♦ LOCKING HANDLE WITH QUICK QUARTER TURN OPERATION
- ♦ MALE THREAD ENDS MOUNT DIRECTLY INTO STRAINER BLOW-OFF CONNECTION
- ♦ PROFESSIONALLY INSTALLED AT OUR FACTORY ENSURES QUALITY AND HELPS TO REDUCE SHIPPING AND LABOR COSTS

TECHNICAL

PRESSURE/TEMPERATURE RATING

BODY: CF8M STAINLESS STEEL

WOG (Non-shock): 3000 PSI @ 100 °F

MAX LIQUID: 80 PSI @ 400 °F

MAX STEAM: 150 PSI @ 366 °F

BALL SEAT: DELRIN

TEMPERATURE: -20 °F ~ 180 °F

SHOWN WITH OPTIONAL
SPRING-RETURN
HANDLE

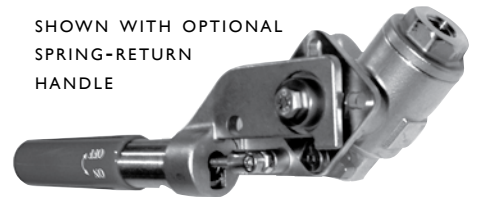

APPLICATIONS

SCREEN CLEANING: DURING NORMAL USE, THE STRAINER SCREEN WILL BECOME CLOGGED WITH FOREIGN MATTER CAUSING THE DIFFERENTIAL PRESSURE TO INCREASE. ONCE THE DIFFERENTIAL PRESSURE HAS REACHED AN UNACCEPTABLE VALUE, BLOW-DOWN CLEANING IS RECOMMENDED. IT IS NOT ADVISABLE TO ALLOW THE DIFFERENTIAL PRESSURE TO INCREASE BY 20 PSI AS THIS MAY CAUSE THE SCREEN TO FAIL AND POSSIBLY DAMAGE DOWNSTREAM EQUIPMENT. IF THE DIFFERENTIAL PRESSURE IS NOT RESTORED TO NORMAL PARAMETERS AFTER BLOW-DOWN CLEANING THEN THE SCREEN MUST BE REMOVED AND CLEANED OR REPLACED.

HAVE TITAN PROFESSIONALLY INSTALL A BV 24 OR BV 25 WHEN PURCHASING A TITAN Y-STRAINER. NOT ONLY WILL YOU BE ASSURED THAT IT IS INSTALLED CORRECTLY, BUT YOU MAY SAVE ON SHIPPING COSTS AS WELL.

SELF-CLEANING Y-STRAINER



TITAN FLOW CONTROL, INC.

YOUR PIPELINE TO THE FUTURE!

Tel: 910-735-0000 ♦ Fax: 910-738-3848 ♦ titan@titanfci.com ♦ www.titanfci.com
290 Corporate Drive ♦ PO Box 7408 ♦ Lumberton, NC 28358



TITAN FLOW CONTROL, Inc.
 290 Corporate Drive
 Lumberton, NC 28358
 Tel: 910.735.0000
 Fax: 910.738.3848

E-mail: titan@titanfci.com
 Web: www.titanfci.com

**BLOW-OFF DRAIN VALVE
 HIGH PRESSURE, DIRECT MOUNT BALL VALVE**

**MODELS: BV 24 (female x female)
 BV 25 (male x female)**

Working Pressure:
 3000 PSI

BILL OF MATERIALS (1)

No.	PART	MATERIAL	QTY
1	Body	CF8M	1
2	End Cap	CF8M	1
3	Ball	CF8M	1
4	Antistatic Stem	T-316 SS	1
5	Ball Seat (2)	DELTRIN	2
6	Ball Seal (2)	PTFE	1
7	Thrust Washer (2)	DELTRIN	1
8	Stem Packing (2)	PTFE	1
8A	O-Ring (2)	VITON	1
9	Thrust Washer (2)	50%-SS 50%-PTFE	1
10	Stem Nut	T-304 SS	1
11	Lock Saddle	T-304 SS	1
12	Handle	T-304 SS	1
13	Stop Bolt	T-304 SS	1
14	Stop Nut	T-304 SS	1
15	Stop Washer	T-304 SS	1
16	Handle Bolt	T-304 SS	1
17	Handle Sleeve	VINYL	1

- BOM represents standard materials. Equivalent or better materials may be substituted at the manufacturer's discretion.
- Denotes recommended spare parts.

Design Notes:

- Two-piece direct mount ball valve
- Working pressure: 3000 psi
- Size: 1/4" ~ 1 1/2" full port - Size: 2" reduced port
- Integrated ISO-5211 mounting pad
- Square stems allows direct mounting to actuator, no additional hardware required
- Blow-out proof stem design
- Anti-static device standard applied between stem to body and stem to ball
- Stem with O-Ring maintains stem alignment, reduces packing side loading and wear
- Fire design complies with API 607-4

DIMENSIONS AND PERFORMANCE DATA

SIZE	in	1/4	3/8	1/2	3/4	1	1 1/4	1 1/2	2
	mm	8	10	15	20	25	32	40	50
ØID	in	.381	.381	.500	.688	.870	1.141	1.366	1.366
	mm	9.7	9.7	12.7	17.5	22.1	29.0	34.7	34.7
ØA	in	F03	F03	F03	F03	F04	F04	F05	F05
	mm	F03	F03	F03	F03	F04	F04	F05	F05
ØB	in	F04	F04	F04	F04	F05	F05	F07	F07
	mm	F04	F04	F04	F04	F05	F05	F07	F07
C	in	4.960	4.960	4.960	4.960	6.141	6.141	7.125	7.125
	mm	126	126	126	126	156	156	181	181
□E	in	.354	.354	.354	.354	.433	.433	.551	.551
	mm	9	9	9	9	11	11	14	14
OF	in	1.019	1.019	1.283	1.511	1.858	2.318	2.606	3.228
	mm	26	26	33	38	47	59	66	82
G	in	1.614	1.614	1.614	1.724	2.106	2.322	2.960	2.960
	mm	41	41	41	44	54	59	75	75
h	in	.314	.314	.314	.314	.393	.393	.511	.511
	mm	8	8	8	8	10	10	13	13
H	in	2.834	2.834	2.834	2.874	3.425	3.661	4.488	4.488
	mm	72	72	72	73	87	93	114	114
L	in	2.952	2.952	2.952	3.188	3.582	4.330	4.763	5.708
	mm	75	75	75	81	91	110	121	145
LI	in	3.500	3.622	3.622	3.897	4.448	5.003	5.551	6.102
	mm	89	92	92	99	113	127	141	155
D	in	.448	.590	.590	.629	.787	.826	.905	.994
	mm	11	15	15	16	20	21	23	25
T	NPT	NPT	NPT	NPT	NPT	NPT	NPT	NPT	NPT
Approximate Weight	lb	1.5	1.5	1.5	2.0	3.2	5.0	8.4	10.7
	kg	.7	.7	.7	.9	1.5	2.3	3.8	4.9
Torque	in/lb	104	104	130	156	208	390	468	468
	Cv	5.3	8	19	35	50	110	180	210

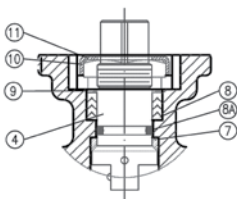
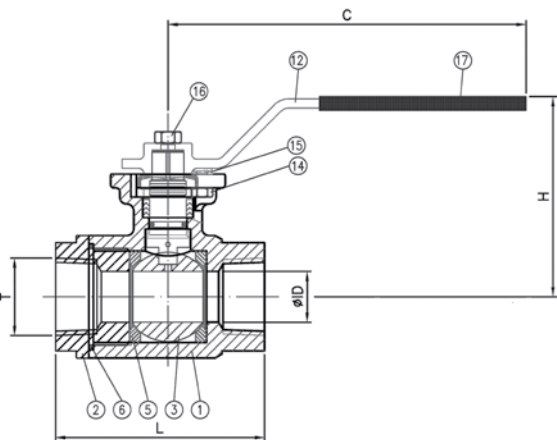

Stem Section Side View

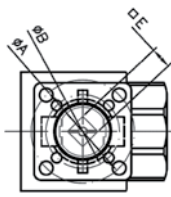
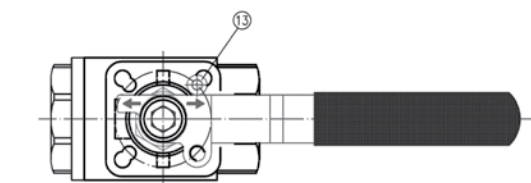

Stem Section Top View

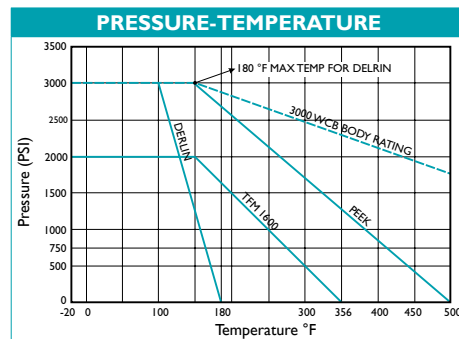

TEST PRESSURE

TYPE	PSI
SEAT (AIR)	80 PSI
SHELL (HYDROSTATIC)	4500 PSI

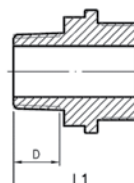

Male Ends

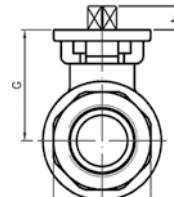

Female Ends

Titan FCI makes every effort to ensure the information presented on our literature accurately reflects exact product specifications. However, as product changes occur, there may be short-term differences between actual product specifications and the information contained within our literature. Titan FCI reserves the right to make design and specification changes to improve our products without prior notification. When required, request certified drawings.

Suction Diffuser Strainer

SD 22-CI

Tri-flow Control Check Valve

TF 21-CI

TITAN

®

Pump Protection

*Titan Flow Control, Inc.
has quality products that you can
depend on, a guarantee that is
critical when considering the set-
up of expensive equipment within a
pump piping system.*

Titan's durable **Suction Diffuser** and **Tri-flow Control Check Valve** are essential to protecting and promoting the longevity of pumps. At the same time, these two products are an economical choice, designed specifically to save space, energy, and installation and maintenance time.

A Titan **Suction Diffuser**, while functioning as a strainer to prevent foreign particles from harming a pump, also has straightening vanes that reduce turbulence in the flow and alleviate stress and erosion on the pump. Titan manufactures each diffuser with a mesh start-up screen that can be removed after the diffuser's start up period. Just one Titan Suction Diffuser replaces three products in a typical pump set up: *an elbow, strainer, and an entry pipe.*

The **Tri-flow Control Check Valve** is a spring-loaded valve that can be adjusted from full flow to complete shut-off. With a graduated position indicator, Titan's Tri-flow is easy to adjust and control flow and its automatic shut-off helps to prevent waterhammer. The Tri-flow is three products in one as it takes the place of a *balance valve, shut-off valve, and check valve.*

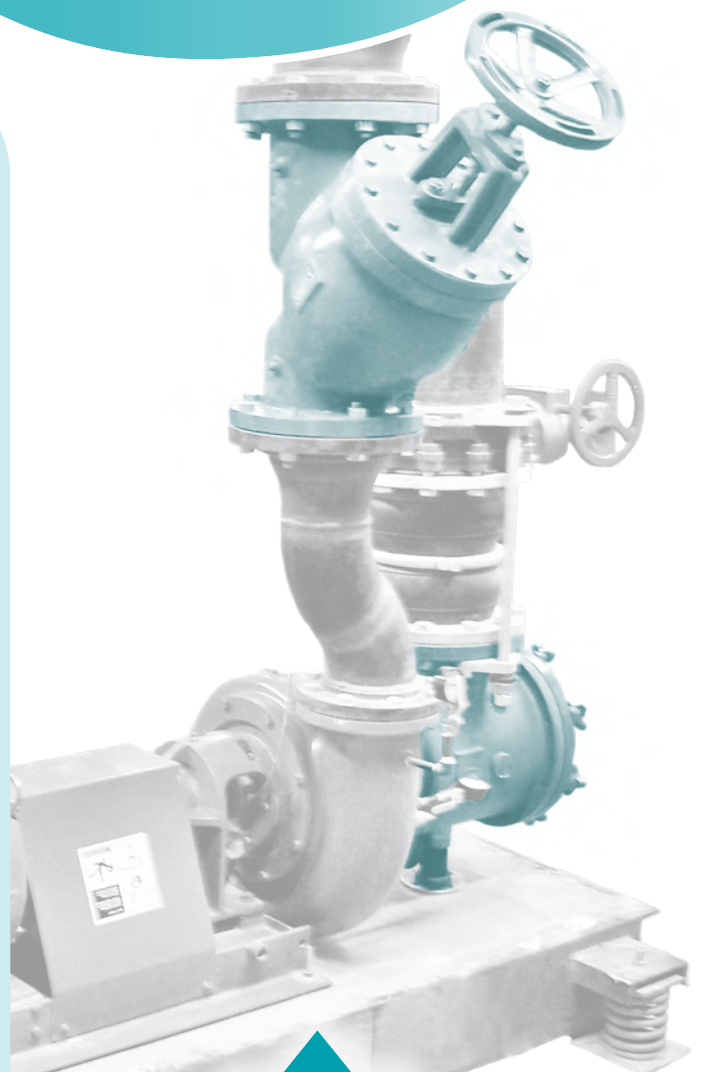

TITAN

TITAN FLOW CONTROL, INC.

290 Corporate Drive
Lumberton, NC 28358
Tel: 910.735.0000

E-mail: titan@titanfci.com
Web: www.titanfci.com
Fax: 910.738.3848



Suction Diffuser

SD 22-CI • 90° Suction Diffuser Strainer • Flanged • ANSI 125



SD 22 CAST IRON

*Saves space,
energy, time
and money as it
functions as three
products in one!*

SIZES AVAILABLE:

2 x 1 1/4"
through
18 x 18"

High quality protection for pumps

Directly mounted to the inlet side of the pump, Titan's Suction Diffuser Strainer is crucial for protecting expensive pumps. Serving as a strainer, it prevents unwanted debris from entering pump. It also helps to increase the service life of the pump as the straightening vanes on the outlet side of the diffuser help to smooth turbulent flow before it enters the pump. An optional magnetic insert that attracts metallic particles is also available. The suction diffuser has cast in supporting pads that fit standard support feet so an additional pipe saddle is not necessary.

Energy efficient and economical design

Titan's Suction Diffuser takes the place of a strainer, reducing elbow, and an entrance pipe. In addition to these specific parts, using the suction diffuser reduces the amount of piping, welds, and bolts required in a traditional pump set-up. Not only is it economical as far as the initial investment, but time and money are saved on installation and servicing. The suction diffuser's minimal head loss, as a result of its large open area ratio, can yield savings in energy costs for many years. Straightening vanes on the outlet side of the diffuser help to maintain a smooth flow throughout the piping system decreasing pressure loss.

Easy to service

The suction diffuser comes with a convenient mesh start-up screen that can be removed after its initial introductory period, thus two screens are not necessary. Quick-open knobs minimize down time while servicing and provide easy access to the strainer. The standard NPT plug can be replaced with an optional blow down valve for easy cleaning.

CODE	DESCRIPTION
ANSI B16.1	Cast Iron Pipe Flanges and Flanged Fittings
ANSI B16.5	Pipe Flanges & Flanged Fittings
MSS SP-6	Standard Finishes for Connecting-end Flanges
MSS SP-25	Standard Marking System for Valves
MSS SP-55	Quality Standard for Valve Castings
ASTM F1199	Standard Specification for Cast and Welded Pipe Line Strainers
ASTM F1200	Standard Specification for Fabricated (Welded) Pipe Line Strainers

Referenced Codes
and Standards

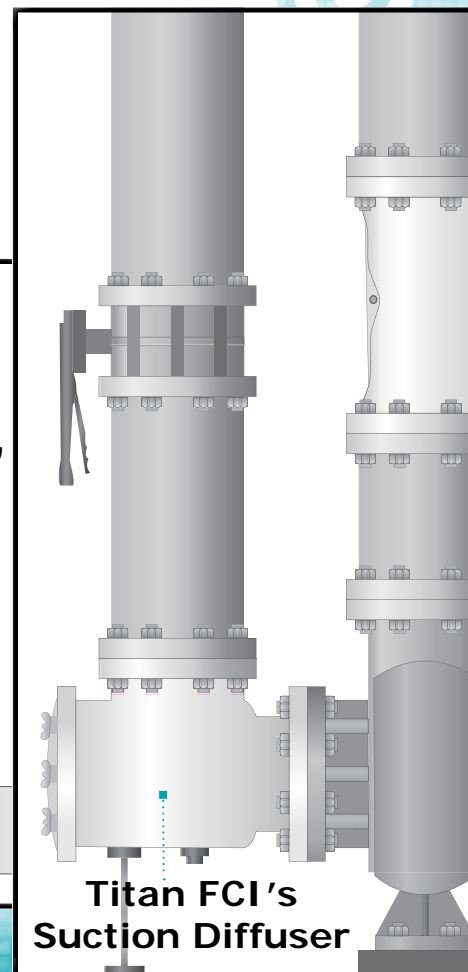
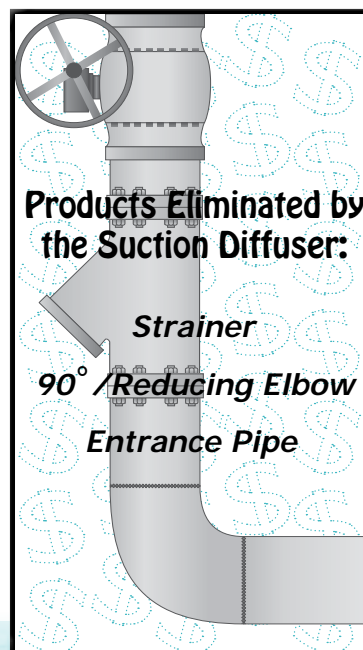

TITAN

Tri-flow Valve

TF 21-CI • Tri-flow Control Check Valve • Flanged • ANSI 125**TF 21
CAST IRON***High Quality,
Cost-effective
Pump Protection***SIZES AVAILABLE:****2" through 20"**

Economical and convenient design

Titan's Tri-flow Control Check Valve is three valves in one, replacing a calibrated balance valve, shut-off valve, and silent check valve for a simplified and inexpensive way to control flow from a pump. Flow through the valve is adjustable from zero to full by the ACME rising stem. A graduated position indicator on the stem provides an accurate check of the valve's position for throttling service, and a hand-wheel is provided with all Tri-flow control check valves for ease of operation. The Tri-Flow also has a soft-seated, dovetail O-ring groove ensuring a bubble tight seal in the closed position.

Quick closure to reduce water hammer

Silent shut-off is achieved via the fully automatic, spring assisted disc that closes near zero flow velocity when functioning as a check valve. The soft seat and quick closure helps to prevent flow reversal, slamming, and surges.

Minimal head loss

The valve's body has a large body with at least a 2 to 1 ratio to connecting pipe. The disc's low cracking pressure reduces the amount of energy required to open the valve.

Titan FCI's Tri-flow Valve

**SAVE
with the
SD 22
and TF 21**

Products Eliminated by the Tri-flow Valve:

*Balance Valve
Shut-off Valve
Check Valve*

MARKETS

Process Industry, Power Industry, Chemical Industry, Water/Oil/Gas, Waste, Mining, Paper

SERVICING

The mesh start-up screen in the suction diffuser should be removed after the initial start-up period. Regular screen cleaning is necessary to clear diffuser of foreign matter build up during normal use and to maintain a low differential pressure. An optional blow down valve is available to assist in screen cleaning.

The Tri-flow can be adjusted as necessary to control the flow. Regular servicing is not required although some parts, such as spring and O-Ring, should be inspected and replaced as needed.

Applications**TITAN****TITAN FLOW CONTROL, INC.**

290 Corporate Drive
Lumberton, NC 28358
Tel: 910.735.0000

E-mail: titan@titanfci.com
Web: www.titanfci.com
Fax: 910.738.3848

Suction Diffuser Strainer

SD 22-CI

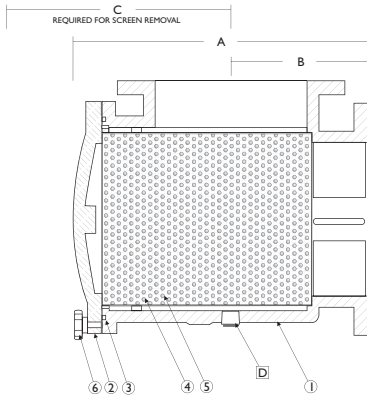

Illustrations are only representative of the products. Variations may exist between different sizes. Please ask for certified drawings when required.

SD 22-CI BILL OF MATERIALS ⁽¹⁾

No.	Part	SD 22-CI
1	Body	Cast Iron A126-B
2	Cover	Cast Iron A126-B
3	O-Ring ⁽²⁾	EPDM
4	Straining Element ⁽²⁾	Stainless Steel 304
5	Start-up Screen ⁽²⁾	Stainless Steel 304 20 Mesh
6	Bolt	Carbon Steel AISI 1035

- Equivalent or better materials may be substituted at the manufacturer's discretion.
- Denotes recommended spare parts.

SD 22-CI DIMENSIONS AND PERFORMANCE DATA

SIZE	in	2 x 1 1/4	2 x 1 1/2	2 x 2	2 1/2 x 2	2 1/2 x 2 1/2	3 x 2	3 x 2 1/2	3 x 3	4 x 3	4 x 4
A DIMENSION TOP OF COVER TO FLANGE	in	9.25	9.25	9.25	10.0	10.0	9.37	10.75	10.62	12.37	12.0
	mm	235	235	235	254	254	238	273	270	314	305
B DIMENSION CENTER TO FLANGE	in	4.5	4.5	4.5	5.0	5.0	4.5	5.75	5.75	6.75	6.5
	mm	114	114	114	127	127	114	146	146	171	165
C DIMENSION SCREEN REMOVAL	in	8.81	8.81	8.81	9.12	9.12	9.62	9.62	9.62	11.5	11.5
	mm	224	224	224	232	232	244	244	244	292	292
D DIMENSION N.P.T.	in	3/4	3/4	3/4	3/4	3/4	3/4	3/4	3/4	3/4	1
	mm	20	20	20	20	20	20	20	20	20	25
WEIGHT (APPROXIMATE)	lb	24.0	26.0	28.0	39.0	40.0	34.0	52.0	53.0	74.0	76.5
	kg	10.9	11.8	12.7	17.7	18.1	15.4	23.6	24.0	33.6	34.7

SIZE	in	5 x 4	5 x 5	6 x 4	6 x 5	6 x 6	8 x 5	8 x 6	8 x 8	10 x 8	10 x 10
A DIMENSION TOP OF COVER TO FLANGE	in	15.0	15.25	12.0	15.98	16.5	19.17	16.5	20.75	21.0	27.0
	mm	381	387	305	406	419	487	419	527	533	686
B DIMENSION CENTER TO FLANGE	in	7.5	7.5	6.5	10.43	8.0	9.0	8.0	9.0	9.0	11.5
	mm	191	191	165	265	203	229	203	229	229	292
C DIMENSION SCREEN REMOVAL	in	14.87	14.87	16.56	16.56	16.56	16.87	16.87	22.87	22.87	30.25
	mm	378	378	421	421	421	429	429	581	581	768
D DIMENSION N.P.T.	in	1	1	1	3/4	1	1	1	1 1/4	1	1 1/4
	mm	25	25	25	19	25	25	25	32	25	32
WEIGHT (APPROXIMATE)	lb	110.5	112.5	96.0	160.5	155.5	185.0	180.0	298.5	296.0	480.0
	kg	50.1	51.0	43.5	72.8	70.5	83.9	81.6	135.4	134.3	217.7

SIZE	in	12 x 8	12 x 10	12 x 12	14 x 10	14 x 12	14x14	16x12	16x14	16x16	18x16*
A DIMENSION TOP OF COVER TO FLANGE	in	21.0	26.68	26.68	25.0	27.0	26.87	32.17	30.25	29.33	36.38
	mm	533	678	678	635	686	683	817	768	745	924
B DIMENSION CENTER TO FLANGE	in	11.0	11.25	12.0	13.0	13.25	13.25	19.25	14.5	14.33	21.81
	mm	280	286	305	330	337	337	489	368	364	554
C DIMENSION SCREEN REMOVAL	in	22.87	33.0	28.75	33.0	31.0	33.12	33.66	31.0	33.12	38.75
	mm	581	838	730	838	787	841	855	787	841	985
D DIMENSION N.P.T.	in	1 1/4	1 1/4	1 1/4	1 1/4	1 1/4	1 1/4	1	1 1/2	C/F	1
	mm	32	32	32	32	32	32	25.4	40	C/F	25.4
WEIGHT (APPROXIMATE)	lb	422.0	498.0	588.0	515.0	554.0	564.0	724.0	748.0	C/F	1600
	kg	191.4	225.9	266.7	233.6	251.3	255.8	328.4	339.3	C/F	725.8

1. Dimensions and weights are for reference only. When required, request certified drawings. * Larger sizes are available. Please consult factory for dimensions.

Tri-flow Control Check Valve

TF 21-CI

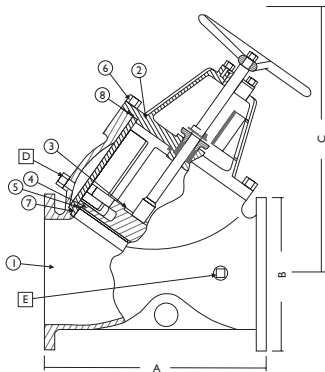

TF 21-CI DIMENSIONS AND PERFORMANCE DATA

SIZE	in	2	2 1/2	3	4	5	6	8	10	12	14	16	20
A DIMENSION FACE TO FACE	in	8.39	9.84	10.05	14.5	16.0	18.0	21.5	25.5	30.12	30.39	33.78	C/F
	mm	213	250	255	368	407	457	546	648	765	772	858	C/F
ØB DIMENSION FLANGE DIAMETER	in	6.0	7.0	7.5	9.0	10.0	11.0	13.5	16.0	19.0	21.0	23.5	C/F
	mm	152	178	191	229	254	279	343	406	483	533	597	C/F
C DIMENSION CLEARANCE, FULL OPEN	in	12.0	12.5	14.0	15.5	19.5	21.5	26.0	27.0	32.0	C/F	C/F	C/F
	mm	305	318	356	394	495	546	660	686	813	C/F	C/F	C/F
D DIMENSION N.P.T.	in	1/2	3/4	1/2	1/2	1/2	3/4	3/4	1	1	3/4	1	C/F
	mm	15	20	15	15	15	20	20	25	25	20	25	C/F
E DIMENSION N.P.T.	in	1/4	1/4	1/4	1/4	1/4	1/4	1/4	1/4	1/4	1/4	1/4	C/F
	mm	8	8	8	8	8	8	8	8	8	8	8	C/F
WEIGHT (APPROXIMATE)	lb	33.0	42.0	59.0	104.0	170.0	202.0	280.0	442.0	816.0	1112.0	1478.0	C/F
	kg	15.0	19.1	26.8	47.2	77.1	91.6	127.0	200.5	370.1	504.4	670.4	C/F
Flow Coefficient	C _v	82	128	188	334	528	765	1371	2153	3105	C/F	C/F	C/F

1. Dimensions and weights are for reference only. When required, request certified drawings.

TF 21-CI BILL OF MATERIALS ⁽¹⁾

No.	Part	TF 21-CI
1	Body	Cast Iron, A126-B
2	Cover	Cast Iron, A126-B
3	Spring ⁽²⁾	Stainless Steel, 300 Series
4	Disc	Ductile Iron A536, Plated
5	Disc Seat	EPDM O-Ring
6	Bolt	Carbon Steel, AISI 1035
7	Seat Guide	Ductile Iron A536, Plated
8	O-Ring ⁽²⁾	EPDM

TF 21-CI's Bill of Materials Notes:

- Equivalent or better materials may be substituted at the manufacturer's discretion.
- Denotes recommended spare parts.

SPRING AND SEAT TEMPERATURE RATINGS

Material	Temperature
EPDM	-20 °F - 300 °F
Stainless Steel	450 °F MAX

PRESSURE TEMPERATURE RATING

**SD 22 AND TF 21
CAST IRON
ASTM A126 B - CLASS 125**

**WOG (Non-Shock)
200 PSI @ 150°F**

*These temperatures are theoretical and may vary during actual operating conditions.



Tel: 910.735.0000
E-mail: titan@titanfci.com
Web: www.titanfci.com
Fax: 910.738.3848



TITAN FLOW CONTROL, INC.

FOOT VALVE ASSEMBLY ♦ GLOBE STYLE DESIGN

ANSI CLASS 150 ♦ DUCTILE IRON ♦ FLANGED ENDS

MODEL: FV 50-DI
(DUCTILE IRON)

SIZE RANGE: 2" ~ 12"

LARGER SIZES AVAILABLE: UP TO 24"



DESIGNED TO SILENTLY
MAINTAIN PRIME DURING
PUMP OUTAGE

FEATURES

- ♦ **DESIGNED FOR LONG SERVICE LIFE**
DUCTILE IRON BODY MAINTAINS THE ANTI-CORROSIVE PROPERTIES OF CAST IRON WHILE ACHIEVING A YIELD STRENGTH COMPARABLE TO CARBON STEEL. DUCTILE IRON ALSO OFFERS HIGHER PRESSURE/TEMPERATURE RATINGS THAN CAST IRON. CARBON AND STAINLESS STEEL UNITS ARE ALSO AVAILABLE UPON REQUEST.
- ♦ **MINIMAL HEAD LOSS**
HEAD LOSS IS MINIMIZED BY PROVIDING A LARGE CROSS-SECTIONAL AREA WHICH EXCEEDS THAT OF THE ADJACENT PIPELINE. ADDITIONALLY, THE SPRING-LOADED, CENTER GUIDED DISC IS DESIGNED WITH VERY LOW CRACKING PRESSURE WHICH REDUCES THE AMOUNT OF ENERGY REQUIRED TO OPEN THE VALVE.
- ♦ **QUICK CLOSURE TO REDUCE WATER HAMMER**
SILENT SHUT-OFF IS ACHIEVED VIA THE FULLY AUTOMATIC, SPRING ASSISTED DISC THAT CLOSES NEAR ZERO FLOW VELOCITY. THE LIGHTWEIGHT, CENTER GUIDED DISC DESIGN CREATES A POSITIVE SHUTOFF PRIOR TO FLOW REVERSAL AND HELPS TO KEEP SLAMMING AND SURGES TO A MINIMUM.
- ♦ **BRONZE METAL-TO-METAL SEATS**
PRECISION MACHINED SEALING SURFACES ALLOW THE FV 50-DI TO MAINTAIN A TIGHT SEAL THAT MEETS OR EXCEEDS API 598 LEAKAGE REQUIREMENTS. RESILIENT SEATS ARE ALSO AVAILABLE TO PROVIDE BUBBLE TIGHT SEALS.
- ♦ **NUMEROUS SCREEN OPTIONS**
THE STANDARD SCREEN CONSTRUCTION MATERIAL IS TYPE-304 STAINLESS STEEL. IN ADDITION, A WIDE VARIETY PERFORATIONS, MESHES, AND MATERIALS ARE READILY AVAILABLE. SCREENS CAN BE BASKET SHAPED OR CONE SHAPED.

TECHNICAL

PRESSURE/TEMPERATURE RATING ⁽¹⁾
DUCTILE IRON - ASTM A536 - CLASS 150

WOG (Non-shock): 250 PSI @ 100 °F

SEAT MATERIAL
TEMPERATURE RANGE

BRONZE: -460 ~ 450 °F

SPRING MATERIAL
MAXIMUM TEMPERATURE

Stainless Steel: 450 °F

1. The bolting pattern for Cast Iron ANSI Class 125 and Ductile Iron ANSI Class 150 are identical thus they are interchangeable.

APPLICATIONS

GENERAL APPLICATION: A FOOT VALVE IS A SPECIAL TYPE OF CHECK VALVE THAT HAS A BUILT-IN STRAINER. IT IS INSTALLED AT THE INTAKE SIDE OF A SUCTION PIPE AND PUMP. ITS PURPOSE IS TO PREVENT THE LOSS OF PRIME WHEN THE LIQUID SOURCE (WET WELL) IS LOWER THAN THE PUMP. PRIME IS DEFINED AS THE CHARGE OF LIQUID REQUIRED TO BEGIN PUMPING ACTION AND PRIMING IS THE PROCESS OF FILLING THE PUMP AND SUCTION PIPE WITH LIQUID.

THE CHECK VALVE PART OF THE FOOT VALVE OPENS WHEN THE PUMP STARTS TO ALLOW LIQUID TO ENTER THE SUCTION PIPE AND PUMP. WHEN THE PUMP STOPS THE CHECK VALVES CLOSES AND PREVENTS THE LIQUID FROM EMPTYING. THUS THE FOOT VALVE ELIMINATES THE NEED TO PRIME THE PUMP EACH TIME IT IS STARTED. THE STRAINER COMPONENT OF THE FOOT VALVE HELPS TO REMOVE UNWANTED DEBRIS FROM THE LIQUID THAT MAY CAUSE DAMAGE TO THE PUMP.

The above data represents common market and service applications. No representation or guarantee, expressed or implied, is given due to the numerous variations of concentrations, temperatures and flow conditions that may occur during actual service.

TITAN FLOW CONTROL, INC.
YOUR PIPELINE TO THE FUTURE!

Tel: 910-735-0000 ♦ Fax: 910-738-3848 ♦ titan@titanfci.com ♦ www.titanfci.com
290 Corporate Drive ♦ PO Box 7408 ♦ Lumberton, NC 28358



TITAN FLOW CONTROL, Inc.

290 Corporate Drive
Lumberton, NC 28358
Tel: 910.735.0000
E-mail: titan@titanfci.com
Web: www.titanfci.com
Fax: 910.738.3848

FOOT VALVE ASSEMBLY

FV 50-DI (Ductile Iron)

Flanged Ends • Globe Style • Center Guided Disc

ANSI Class
150 lb

BILL OF MATERIALS (1)

No.	PART	FV 50-DI
1	Body	Ductile Iron ASTM A536
2	Disc (2)	Cast Bronze ASTM B62
3	Spring (2)	Series 300 Stainless Steel
4	Bushing (2)	Cast Bronze ASTM B62
5	Seat (2) (3)	Cast Bronze ASTM B62
6	Bolts	Stainless Steel
7	Screen	Type 304 Stainless Steel

1. Bill of Materials represents standard materials. Equivalent or better materials may be substituted at the manufacturer's discretion.
2. Denotes recommended spare parts.
3. Resilient Seats (Buna-N) are available upon request.

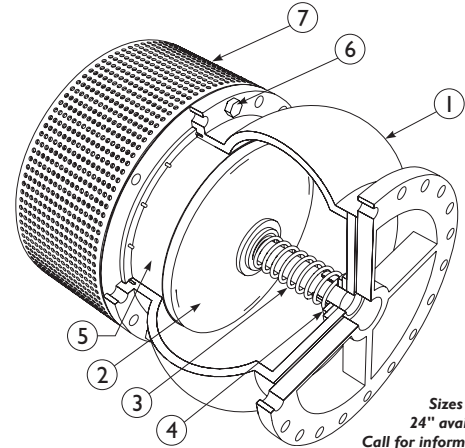
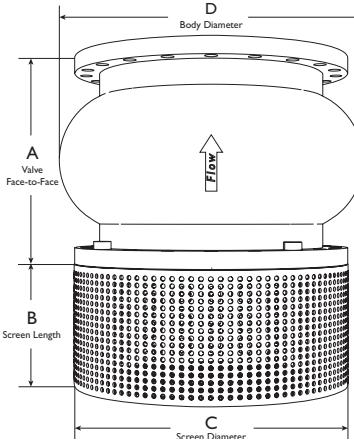

Sizes up to 24" available.
Call for information.

DIMENSIONS AND PERFORMANCE DATA (1)

SIZE	in	2	2 1/2	3	4	5	6	8	10	12
	mm	50	65	80	100	125	150	200	250	300
A DIMENSION FACE TO FACE	in	6.25	7.00	7.50	8.50	9.50	10.50	13.50	16.25	20.25
	mm	159	178	191	216	242	267	343	413	515
B DIMENSION SCREEN LENGTH	in	3.00	3.00	3.00	3.00	4.00	5.00	6.00	7.00	8.00
	mm	77	77	77	77	102	127	153	178	204
ØC DIMENSION SCREEN DIAMETER	in	6.00	7.00	7.50	9.00	10.00	11.00	13.50	16.00	19.00
	mm	153	178	191	229	254	280	343	407	483
ØD DIMENSION BODY DIAMETER	in	4.625	5.75	6.625	8.625	10.00	11.125	15.84	17.687	21.25
	mm	117	146	168	219	254	283	402	449	540
ASSEMBLED WEIGHT	lb	25.0	35.0	36.5	61.0	76.0	91.5	180.0	265.0	411.0
	kg	11.3	15.9	16.6	27.7	34.5	41.5	81.6	120.1	186.2
Flow Coefficient	C _v	65	105	150	265	410	600	1100	1800	2500
Cracking Pressure (2)	psi	≤ .5	≤ .5	≤ .5	≤ .5	≤ .5	≤ .5	≤ .5	≤ .5	≤ .5

1. Dimensions, weights, and flow coefficients are provided for reference only. When required, always request certified drawings.
2. Cracking pressure is for horizontal installations only. For vertical installations, please consult factory.

Additional Design & Technical Notes:

- The FV 50-DI is designed to fit Cast Iron ANSI Class 125 and Ductile Iron ANSI Class 150 Flanges. The bolting pattern for Cast Iron ANSI Class 125 and Ductile Iron ANSI Class 150 are identical.
- Ductile Iron body maintains the anti-corrosive properties of Cast Iron while achieving a yield strength comparable to Carbon Steel. Ductile Iron also offers higher pressure & temperature ratings than Cast Iron.
- Screens are available in either basket shaped or cone shaped. A wide variety of perforations, meshes, and materials are available for screens.
- Resilient seats (Buna-N) are available upon request. Please contact factory.

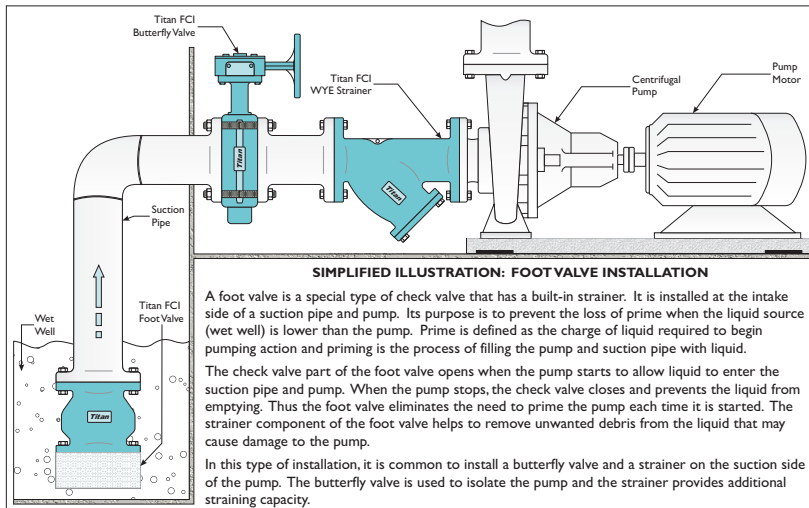

PRESSURE - TEMPERATURE RATINGS (1)

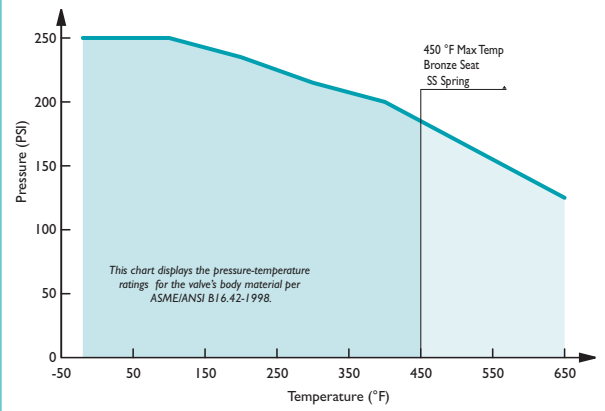

1. This chart displays the pressure-temperature ratings for the valve's body. Max temperature limits have been added for seat and spring materials.

PRESSURE - TEMPERATURE RATING

ANSI CLASS 150	ASTM A536
WOG (Non-shock)	250 PSI @ 100 °F

MAX TEMPERATURE SPRING

SPRING	Max Temperature
Stainless Steel	450 °F

REFERENCED STANDARDS & CODES

CODE	DESCRIPTION
ANSI B16.42	Ductile Iron Pipe Flanges and Flanged Fittings
ANSI B16.5	Pipe Flanges & Flanged Fittings
MSS SP-6	Standard Finishes for Connecting-end Flanges
MSS SP-25	Standard Marking System for Valves
MSS SP-55	Quality Standard for Valve Castings

TEMPERATURE RANGE SEAT

SEAT	Temperature
Bronze	-460 °F @ 450 °F

The listed pressure and temperature ratings are theoretical and may vary during actual operating conditions.

Titan FCI makes every effort to ensure the information presented on our literature accurately reflects exact product specifications. However, as product changes occur, there may be short-term differences between actual product specifications and the information contained within our literature. Titan FCI reserves the right to make design and specification changes to improve our products without prior notification. When required, request certified drawings.

Call Titan (910) 735-0000 today to discuss how our identification tags can benefit your company!

TITAN FLOW CONTROL

290 Corporate Drive
Lumberton, NC 28358
Tel: 910.735.0000

E-mail: titan@titanfci.com
Web: www.titanfci.com
Fax: 910.738.3848

Identification Tags

TITAN

TITAN FLOW CONTROL, INC

Great for Identifying Check Valves and other products

Organize and Track Small Items or Parts

Leave a Lasting, Professional Impression with Stainless Steel Tags

Titan Flow Control, Inc. has the capability to create identification tags for all your marking and labeling needs.

CONVENIENTLY IDENTIFY PRODUCTS Tags can be marked with product numbers, dates, batch numbers, logos, etc and then attached to the product before its shipped to you for easy identification

SIMPLIFY AND ORGANIZE Titan can mark small parts, tools, keys, and more so you can stay organized.

MAKE AN IMPRESSION High quality tags look professional. They are available in a wide variety of sizes, shapes, and materials. Titan FCI can even **add your company's logo and information!** (Graphic design charges may apply.)

Identification Tags

TITAN FLOW CONTROL, INC



Contact Titan Flow Control, Inc. for any of your identification needs. Two sizes of Standard Stainless Steel Tags (as illustrated below) are available for easy ordering, but Titan can make tags in a variety of sizes and specifications.

STANDARD STAINLESS STEEL TAGS

- Stainless Steel
- Two Standard Sizes Available:
 - 2" x 3/4" (50 mm x 20 mm)
 - 3" x 1" (80 mm x 25 mm)
- Other sizes and shapes are available. Contact factory.

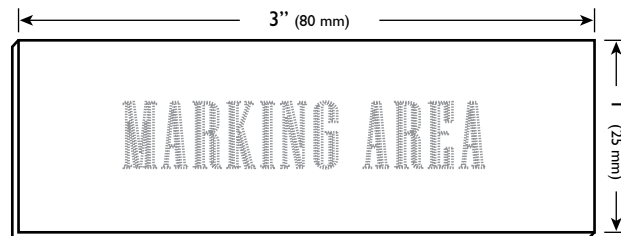
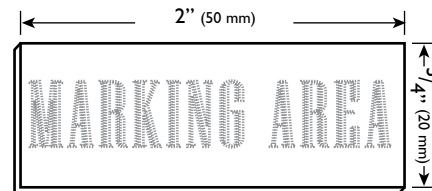

APPLICATIONS

- Tracking of equipment and inventory
- Preventing theft
- Asset management
- Assigning serial numbers

FEATURES

- Low stress on materials or tag being imprinted
- High legibility
- Permanent marking

SPECIFICATIONS

- Maximum marking area: 4" x 4" (100 x 100 mm)
- Tag height/thickness range: 0.02" To 12" (0.5 To 300 mm)
- Character range: 0.04" To 3.15" (0.5 To 80 mm at intervals of 0.1 mm)

CAPABILITIES

- Markings on various materials (Treated and untreated metal, plastic, wood, and more)
- Numerous shapes and sizes of tags
- Logo design (Graphic design fees may apply)
- Dates, times, and batch numbering capabilities
- Linear, angular, and circular markings
- Special markings such as reversed, mirrored, and reflected



Titan FCI makes every effort to ensure the information presented on our literature accurately reflects exact product specifications. However, as product changes occur, there may be short-term differences between actual product specifications and the information contained within our literature. Titan FCI reserves the right to make design and specification changes to improve our products without prior notification. Some options may not be available on all types of identification tags. For exact product specifications, please consult the Titan FCI factory.



TITAN FLOW CONTROL

290 Corporate Drive
Lumberton, NC 28358
Tel: 910.735.0000

E-mail: titan@titanfci.com
Web: www.titanfci.com
Fax: 910.738.3848

TITAN FLOW CONTROL, INC.



Proudly Producing Pipeline Products For:

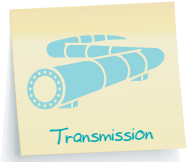
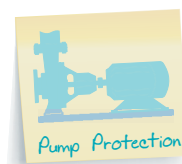
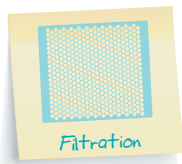
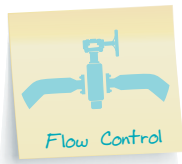
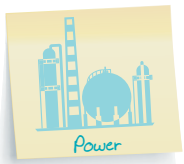

And much, much more...